

TFT LCD Tentative Specification

MODEL NO.: V320B1 - L01

LCD TV Head Division			
AVP	鄧振峰		
QRA Dept.	TVHD/PDD		
	DDIII	DDII	DDI
Approval	Approval	Approval	Approval
陳亦一	李江洋	藍文錦	林文聰
LCD TV Marketing and Product Management Division			
Product Manager	徐子祥 陳立宜		

- CONTENTS -

REVISION HISTORY	-----	3
1. GENERAL DESCRIPTION	-----	4
1.1 OVERVIEW		
1.2 FEATURES		
1.3 APPLICATION		
1.4 GENERAL SPECIFICATIONS		
1.5 MECHANICAL SPECIFICATIONS		
2. ABSOLUTE MAXIMUM RATINGS	-----	5
2.1 ABSOLUTE RATINGS OF ENVIRONMENT		
2.2 ELECTRICAL ABSOLUTE RATINGS		
2.2.1 TFT LCD MODULE		
2.2.2 BACKLIGHT INVERTER UNIT		
3. ELECTRICAL CHARACTERISTICS	-----	7
3.1 TFT LCD MODULE		
3.2 BACKLIGHT UNIT		
3.2.1 CCFL(Cold Cathode Fluorescent Lamp) CHARACTERISTICS		
3.2.2 INVERTER CHARACTERISTICS		
3.2.3 INVERTER INTERFACE CHARACTERISTICS		
4. BLOCK DIAGRAM	-----	12
4.1 TFT LCD MODULE		
5. INTERFACE PIN ASSIGNMENT	-----	13
5.1 TFT LCD MODULE		
5.2 BACKLIGHT UNIT		
5.3 INVERTER UNIT		
5.4 BLOCK DIAGRAM OF INTERFACE		
5.5 LVDS INTERFACE		
5.6 COLOR DATA INPUT ASSIGNMENT		
6. INTERFACE TIMING	-----	19
6.1 INPUT SIGNAL TIMING SPECIFICATIONS		
6.2 POWER ON/OFF SEQUENCE		
7. OPTICAL CHARACTERISTICS	-----	21
7.1 TEST CONDITIONS		
7.2 OPTICAL SPECIFICATIONS		
8. PRECAUTIONS	-----	25
8.1 ASSEMBLY AND HANDLING PRECAUTIONS		
8.2 SAFETY PRECAUTIONS		
9. MECHANICAL CHARACTERISTICS	-----	26

REVISION HISTORY

Version	Date	Page (New)	Section	Description
Ver 0.0	Apr.26,'04	All	All	Tentative Specification was first issued.

1. GENERAL DESCRIPTION

1.1 OVERVIEW

V320B1- L01 is a 32" TFT Liquid Crystal Display module with 16-CCFL Backlight unit and 1ch-LVDS interface. This module supports 1366 x 768 WXGA format and can display true 16.7M colors (8-bit/color). The inverter module for backlight is built-in.

1.2 FEATURES

- Ultra wide viewing angle – Super MVA technology
- High brightness (550 nits)
- High contrast ratio (800:1)
- Fast response time
- High color saturation NTSC 75%
- WXGA (1366 x 768 pixels) resolution
- DE (Data Enable) only mode
- LVDS (Low Voltage Differential Signaling) interface

1.3 APPLICATION

- TFT LCD display

1.4 GENERAL SPECIFICATIONS

Item	Specification	Unit	Note
Active Area	708.954(H) x 398.592 (V) (32.02" diagonal)	mm	(1)
Bezel Opening Area	714.96 (H) x 404.6 (V)	mm	
Driver Element	a-si TFT active matrix	-	-
Pixel Number	1366 x R.G.B. x 768	pixel	-
Pixel Pitch (Sub Pixel)	0.1730 (H) x 0.5190 (V)	mm	-
Pixel Arrangement	RGB vertical stripe	-	-
Display Colors	16.7M	color	-
Display Operation Mode	Transmissive mode / Normally black	-	-
Surface Treatment	Hardness : 3H, Haze : 40% Anti-reflective coating < 2% reflection	-	-

1.5 MECHANICAL SPECIFICATIONS

	Item	Min.	Typ.	Max.	Unit	Note
Module Size	Horizontal(H)		760	-	mm	(1), (2)
	Vertical(V)		450		mm	
	Depth(D)	-	-	49	mm	
	Weight	-	6100		g	-

Note (1) Please refer to the attached drawings for more information of front and back outline dimensions.

Note (2) Module Depth does not include connectors.

2. ABSOLUTE MAXIMUM RATINGS

2.1 ABSOLUTE RATINGS OF ENVIRONMENT

Item	Symbol	Value		Unit	Note
		Min.	Max.		
Storage Temperature	T _{ST}	-20	+60	°C	(1)
Operating Ambient Temperature	T _{OP}	0	+50	°C	(1), (2)
Shock (Non-Operating)	S _{NOF}	-	100	G	(3), (5)
Vibration (Non-Operating)	V _{NOF}	-	1.0	G	(4), (5)

Note (1) Temperature and relative humidity range is shown in the figure below.

(a) 90 %RH Max. (Ta = 40 °C).

(b) Wet-bulb temperature should be 39 °C Max. (Ta > 40 °C).

(c) No condensation.

Note (2) The maximum operating temperature is based on the test condition that the surface temperature of display area is less than or equal to 60 °C with LCD module alone in a temperature controlled chamber. Thermal management should be considered in your product design to prevent the surface temperature of display area from being over 60 °C. The range of operating temperature may degrade in case of improper thermal management in your product design.

Note (3) 2 ms, half sine wave, 1 time for ± X, ± Y, ± Z.

Note (4) 10 ~ 200 Hz, 10 min, 1 time each X, Y, Z.

Note (5) At testing Vibration and Shock, the fixture in holding the module has to be hard and rigid enough so that the module would not be twisted or bent by the fixture.

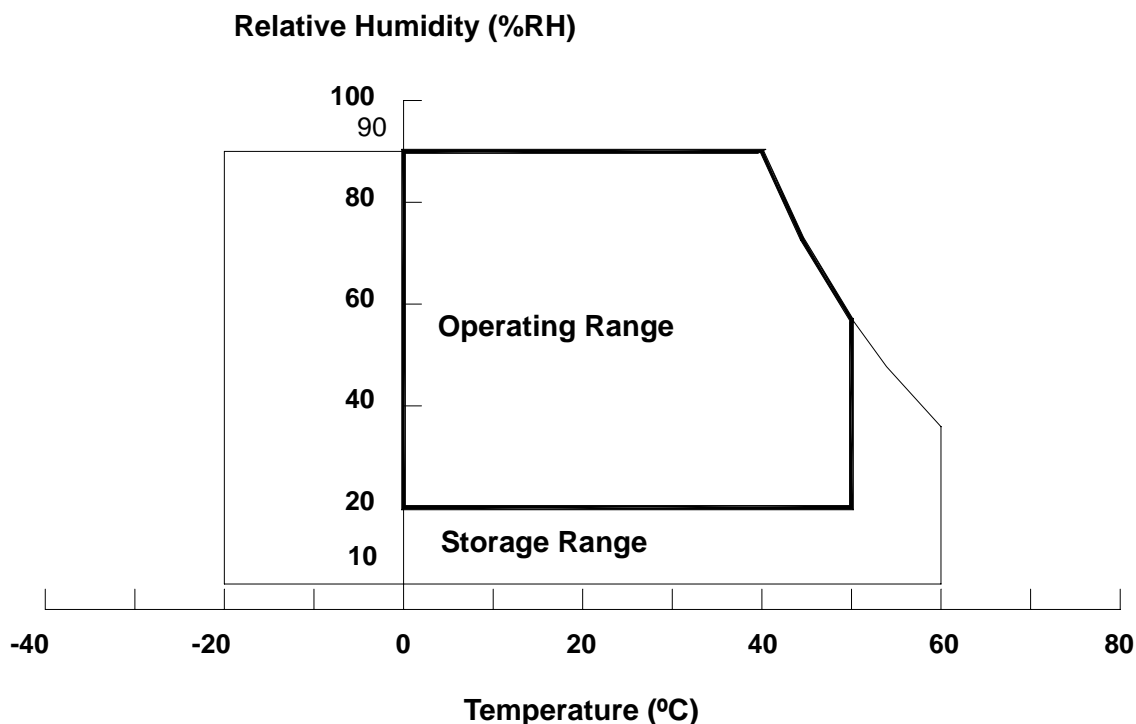

2.2 ELECTRICAL ABSOLUTE RATINGS

2.2.1 TFT LCD MODULE

Item	Symbol	Value		Unit	Note
		Min.	Max.		
Power Supply Voltage	Vcc	(-0.3)	(6.0)	V	

2.2.2 BACKLIGHT UNIT

Item	Symbol	Test Condition	Min.	Type	Max.	Unit	Note
Lamp Voltage	V _W	Ta = 25	-	-	3000	V _{RMS}	
Input Voltage	V _{BL}	-	0	-	(26.4)	V	(1), (2), I _L = (4.8) mA
Control Signal Level	-	-	-0.3	-	7	V	(1), (2), (4)

Note (1) Permanent damage to the device may occur if maximum values are exceeded. Functional operation should be restricted to the conditions described under normal operating conditions.

Note (2) Specified values are for lamp and inverter (Refer to 3.2 for further information).

Note (3) Protect inverters from moisture condensation and freezing.

Note (4) The control signals includes On/Off Control, Internal PWM Control, External PWM Control and Internal/External PWM Selection.

3. ELECTRICAL CHARACTERISTICS

3.1 TFT LCD MODULE

Ta = 25 ± 2 °C

Parameter	Symbol	Value			Unit	Note	
		Min.	Typ.	Max.			
Power Supply Voltage	V _{CC}	4.5	5.0	5.5	V	(1)	
Ripple Voltage	V _{RP}	-	-	100	mV		
Rush Current	I _{RUSH}	-	-	2.45	A	(2)	
Power Supply Current	White	-	1.49	-	A	(3)	
	Black	-	0.85	-	A		
	Vertical Stripe	-	1.23	-	A		
LVDS Interface	Differential Input High Threshold Voltage	V _{LVTH}	-	-	+100	mV	
	Differential Input Low Threshold Voltage	V _{LVTL}	-100	-	-	mV	
	Common Input Voltage	V _{LVC}	1.125	1.25	1.375	V	
	Terminating Resistor	R _T	-	100	-	ohm	
CMOS interface	Input High Threshold Voltage	V _{IH}	2.7	-	3.3	V	
	Input Low Threshold Voltage	V _{IL}	0	-	0.7	V	

Note (1) The module should be always operated within above ranges.

Note (2) Measurement Conditions:

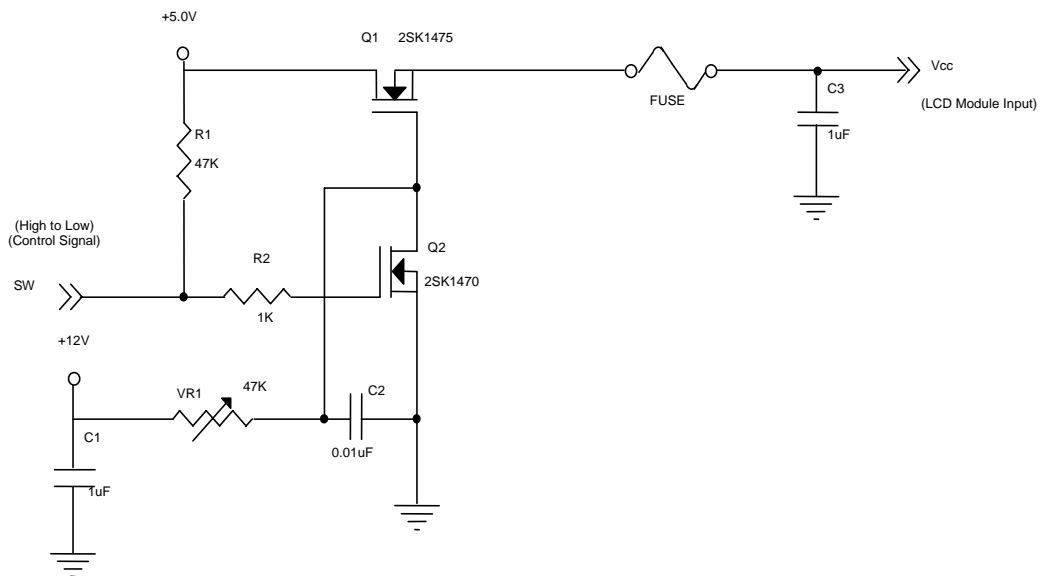

Vcc rising time is 470us

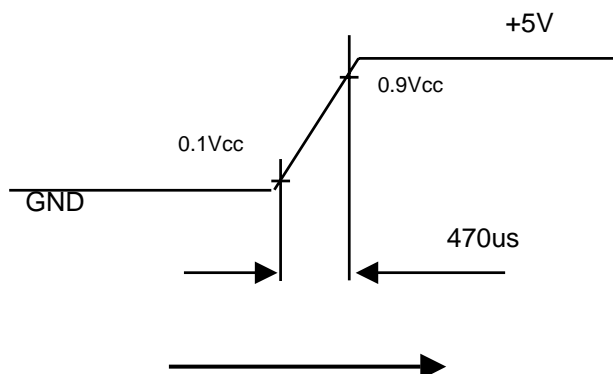

Note (3) The specified power supply current is under the conditions at $V_{CC} = 5\text{ V}$, $T_a = 25 \pm 2\text{ }^\circ\text{C}$, $f_v = 60\text{ Hz}$, whereas a power dissipation check pattern below is displayed.

a. White Pattern

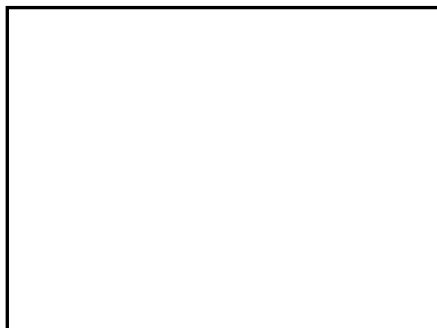

Active Area

b. Black Pattern



Active Area

c. Vertical Stripe Pattern

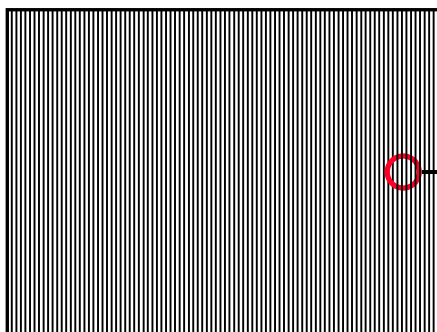

Active Area

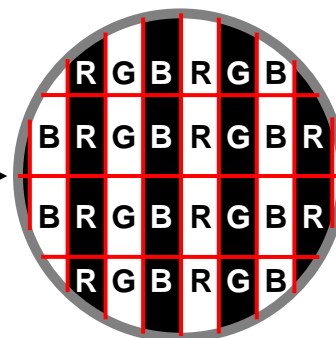

3.2 BACKLIGHT INVERTER UNIT

3.2.1 CCFL (Cold Cathode Fluorescent Lamp) CHARACTERISTICS ($T_a = 25 \pm 2\text{ }^\circ\text{C}$)

Parameter	Symbol	Value			Unit	Note
		Min.	Typ.	Max.		
Lamp Voltage	V_W	-	1270	-	V_{RMS}	$I_L = (4.8)\text{mA}$
Lamp Current	I_L	(4.5)	(4.8)	(5.1)	mA_{RMS}	(1)
Lamp Starting Voltage	V_S	-	(2450)	-	V_{RMS}	(2), $T_a = 0\text{ }^\circ\text{C}$
		-	(2360)	-	V_{RMS}	(2), $T_a = 25\text{ }^\circ\text{C}$
Operating Frequency	F_O	50	-	70	KHz	(3)
Lamp Life Time	L_{BL}	50K	60K	-	Hrs	(4)

3.2.2 INVERTER CHARACTERISTICS ($T_a = 25 \pm 2 \text{ }^\circ\text{C}$)

Parameter	Symbol	Value			Unit	Note
		Min.	Typ.	Max.		
Power Consumption	P_{BL}	-	(122)	-	W	(5), $I_L = (4.8)\text{mA}$
Input Voltage	V_{BL}	21.6	24	26.4	V_{DC}	
Input Current	I_{BL}	-	(5.1)	-	A	Non Dimming
Input Ripple Noise	-	-	-	500	mV_{P-P}	$V_{BL}=21.6\text{V}$
Backlight Turn on Voltage	V_{BS}	(2450)	-	3000	V_{RMS}	$T_a = 0 \text{ }^\circ\text{C}$ (6)
		(2360)	-	3000	V_{RMS}	$T_a = 25 \text{ }^\circ\text{C}$ (6)
Oscillating Frequency	F_W	-	(60)	-	kHz	
Dimming frequency	F_B	150	160	170	Hz	
Minimum Duty Ratio	D_{MIN}	-	20	-	%	

Note (1) Lamp current is measured by utilizing high frequency current meters as shown below:

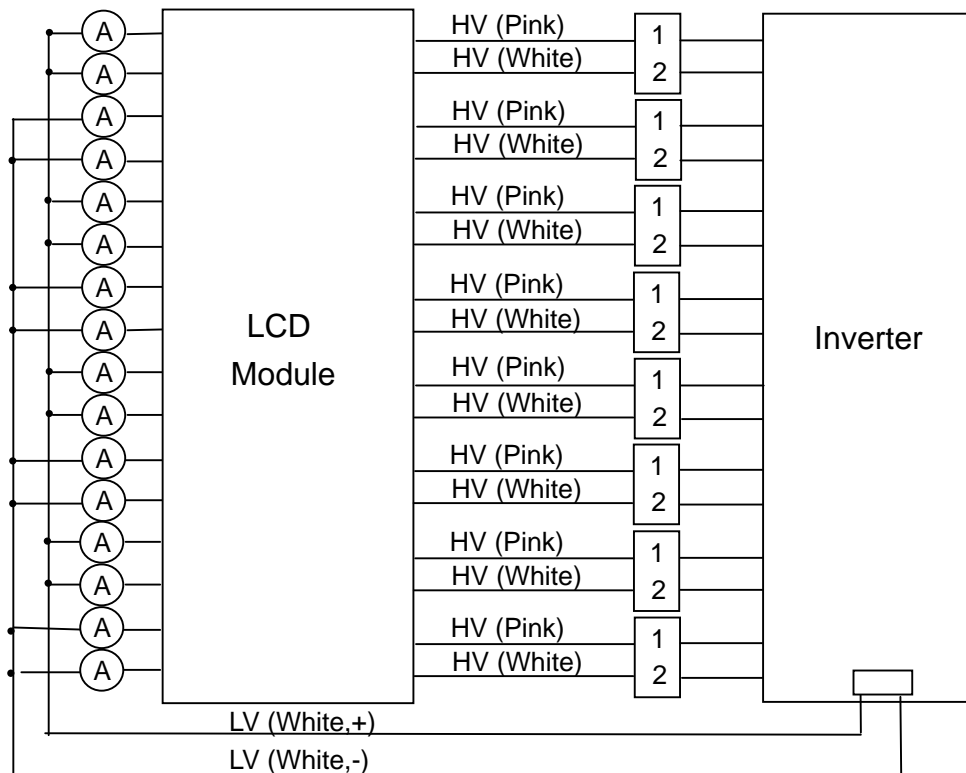

Note (2) The lamp starting voltage V_s should be applied to the lamp for more than 1 second under starting up duration. Otherwise the lamp could not be lighted on completed.

Note (3) The lamp frequency may produce interference with horizontal synchronous frequency from the display, and this may cause line flow on the display. In order to avoid interference, the lamp frequency should be detached from the horizontal synchronous frequency and its harmonics as far as possible.

Note (4) The life time of a lamp is defined as when the brightness is larger than 50% of its original value and the effective discharge length is longer than 80% of its original length (Effective discharge

length is defined as an area that has equal to or more than 70% brightness compared to the brightness at the center point.) as the time in which it continues to operate under the condition $T_a = 25 \pm 2$ and $I_L = (4.5) \sim (5.1) \text{ mA}_{\text{RMS}}$.

Note (5) The power supply capacity should be higher than the total inverter power consumption P_{BL} . Since the pulse width modulation (PWM) mode was applied for backlight dimming, the driving current changed as PWM duty on and off. The transient response of power supply should be considered for the changing loading when inverter dimming.

Note (6) The backlight turn on voltage should be under the rated withstand voltage of transformer.

3.2.3 INVERTER INTERFACE CHARACTERISTICS

Item	Symbol	Test Condition	Min.	Typ.	Max.	Unit	Note	
On/Off Control Voltage	ON	V_{BLON}	-	2.0	-	5.0	V	
	OFF		-	0	-	0.8	V	
Internal/External PWM Select Voltage	HI	V_{SEL}	-	2.0	-	5.0	V	
	LO		-	0	-	0.8	V	
Internal PWM Control Voltage	MAX	V_{IPWM}	$V_{\text{SEL}} = \text{L}$	-	-	3.0	V	minimum duty ratio
	MIN			-	0	-	V	maximum duty ratio
External PWM Control Voltage	HI	V_{EPWM}	$V_{\text{SEL}} = \text{H}$	2.0	-	5.0	V	duty on
	LO			0	-	0.8	V	duty off
Control Signal Rising Time	T_r	-	-	-	100	ms		
Control Signal Falling Time	T_f	-	-	-	100	ms		
PWM Signal Rising Time	T_{PWMR}	-	-	-	50	us		
PWM Signal Falling Time	T_{PWMF}	-	-	-	50	us		
Input impedance	R_{IN}	-	1	-	-	M		
BLON Delay Time	T_{on}	-	300	-	500	ms		
BLON Off Time	T_{off}	-	300	-	500	ms		

Note (1) The SEL signal should be valid before backlight turns on by BLON signal. It is inhibited to change the internal/external PWM selection (SEL) during backlight turn on period.

Note (2) The power sequence and control signal timing are shown as the following figure.

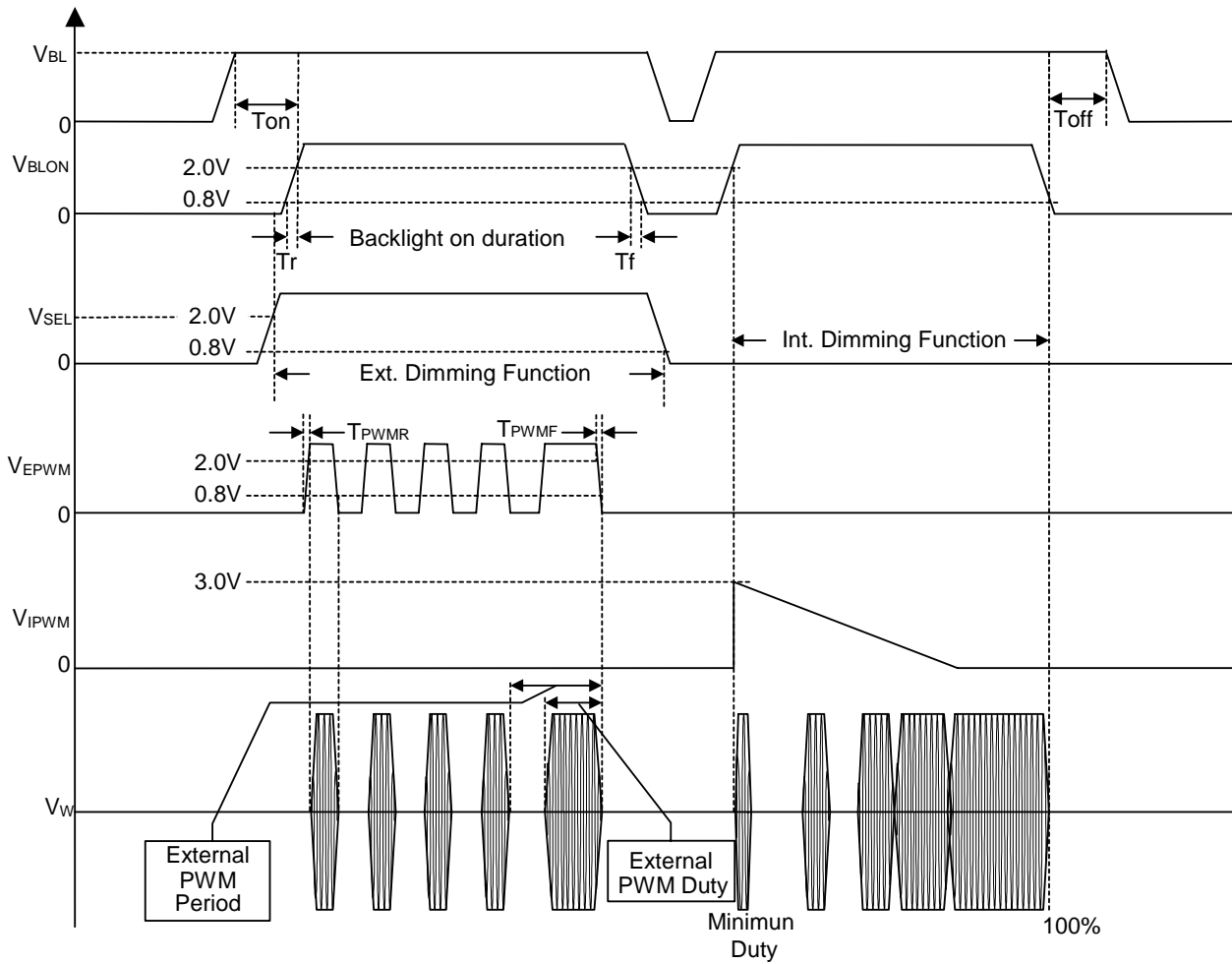

4. BLOCK DIAGRAM

4.1 TFT LCD MODULE

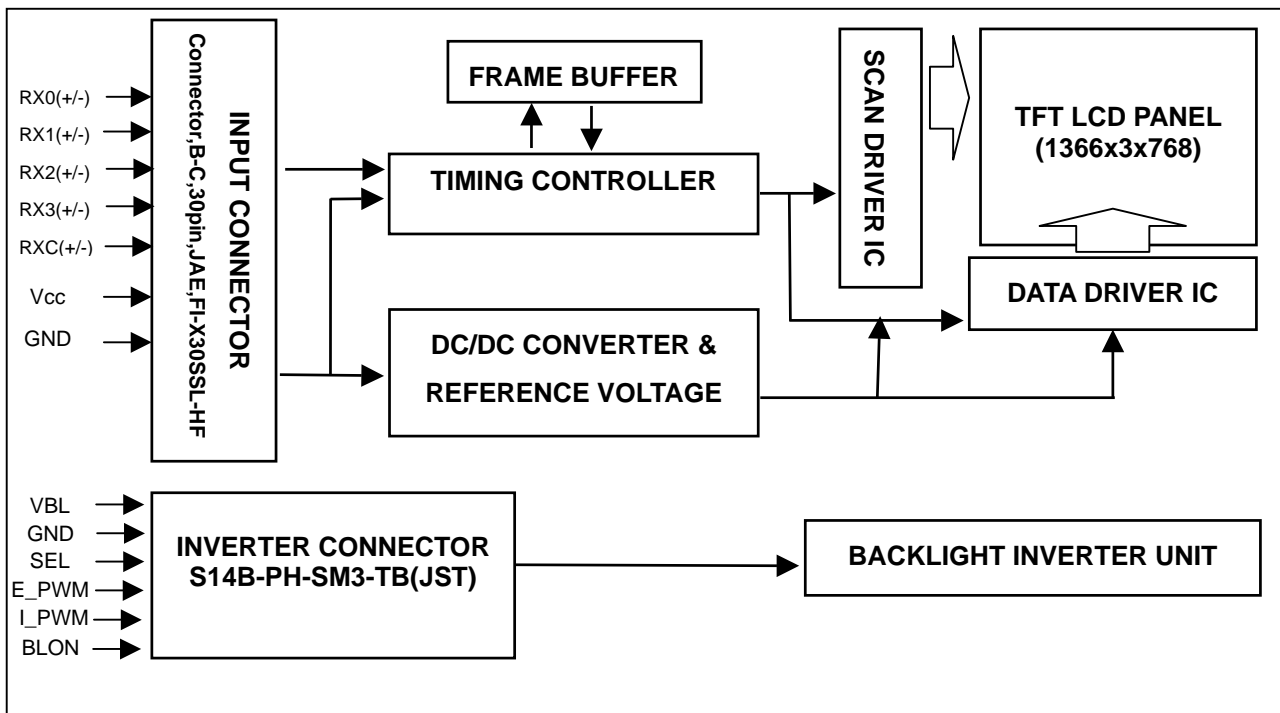

5. INTERFACE PIN CONNECTION

5.1 TFT LCD MODULE

CN1 Connector Pin Assignment

Pin No.	Symbol	Description	Note
1	GND	Ground	
2	RPF	Display Rotation	(3)
3	NC	No Connection	(2)
4	NC	No Connection	(2)
5	NC	No Connection	(2)
6	ODSEL1	Overdrive Lookup Table Selection	(4)
7	ODSEL2	Overdrive Lookup Table Selection	(4)
8	GND	Ground	
9	RX0-	Negative transmission data of pixel 0	
10	RX0+	Positive transmission data of pixel 0	
11	RX1-	Negative transmission data of pixel 1	
12	RX1+	Positive transmission data of pixel 1	
13	RX2-	Negative transmission data of pixel 2	
14	RX2+	Positive transmission data of pixel 2	
15	RXCLK-	Negative of clock	
16	RXCLK+	Positive of clock	
17	RX3-	Negative transmission data of pixel 3	
18	RX3+	Positive transmission data of pixel 3	
19	GND	Ground	
20	GND	Ground	
21	GND	Ground	
22	GND	Ground	
23	GND	Ground	
24	GND	Ground	
25	GND	Ground	
26	VCC	Power supply: +5V	
27	VCC	Power supply: +5V	
28	VCC	Power supply: +5V	
29	VCC	Power supply: +5V	
30	VCC	Power supply: +5V	

Note (1) CN1 Connector Part No.: Connector,B-C,30pin,JAЕ,FI-X30SSL-HF or compatible

Note (2) Reserved for internal use. Left it open.

Note (3) Low : normal display (default), High : display with 180 degree rotation

Note (4) Overdrive lookup table selection. The Overdrive lookup table should be selected in accordance with the frame rate to optimize image quality.

ODSEL2	ODSEL1	Remark
L	L	Lookup table was optimized for 60 Hz frame rate.
L	H	Lookup table was optimized for 50 Hz frame rate.
H	L	Reserved. Do not use.
H	H	Reserved. Do not use.

5.2 BACKLIGHT UNIT

The pin configuration for the housing and leader wire is shown in the table below.

CN3-CN10 (Housing): BHR-03VS-1

Pin	Name	Description	Wire Color
1	HV	High Voltage	Pink
2	HV	High Voltage	White

Note (1) The backlight interface housing for high voltage side is a model BHR-03VS-1, manufactured by JST.

The mating header on inverter part number is SM02(8.0)B-BHS-1-TB.

CN11 (Housing): ZHR-2 or equivalent

Pin	Name	Description	Wire Color
1	LV	Low Voltage (+)	Gray
2	LV	Low Voltage (-)	White

Note (2) The backlight interface housing and return cable for low voltage side is a model ZHR-2 or equivalent, manufactured by JST or equivalent. The mating header on inverter part number is S2B-ZR-SM3A-TF or equivalent.

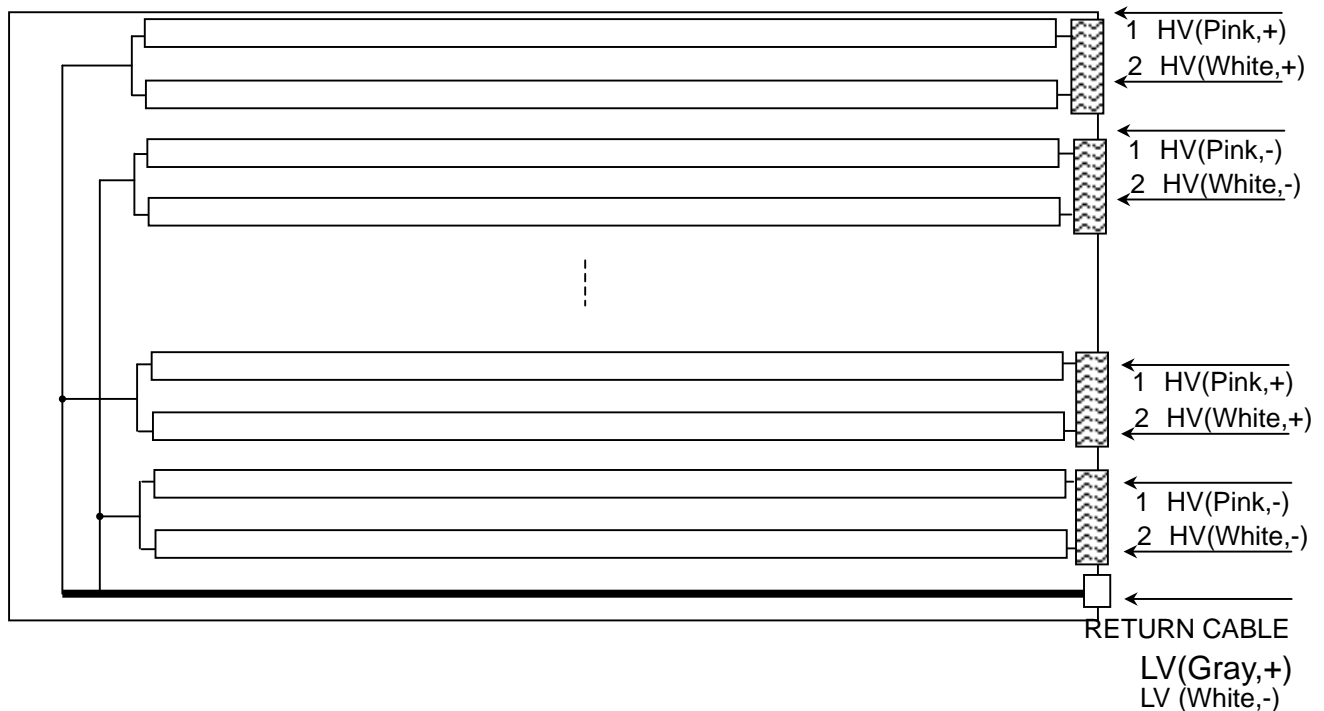

5.3 INVERTER UNIT

CN1(Header):S10B-PH-SM3-TB(JST) or equivalent.

Pin	Name	Description
1	VBL	+24V Power input
2		
3		
4		
5		
6	GND	Ground
7		
8		
9		
10		

CN2(Header): S12B-PH-SM3-TB(JST) or equivalent.

Pin	Name	Description
1	VBL	+24V Power input
2		
3		
4		
5	NC	NC
6	GND	Ground
7		
8		
9	SEL	Internal/external PWM selection High : external dimming Low : internal dimming
10	E_PWM	External PWM control signal E_PWM should be connected to low when internal PWM was selected (SEL = low).
11	I_PWM	Internal PWM control signal I_PWM should be connected to ground when external PWM was selected (SEL = high).
12	BLON	Backlight on/off control

CN3-CN10(Header): SM02(8.0)B-BHS-1-TB(JST)

Pin	Name	Description
1	CCFL HOT	CCFL high voltage
2	CCFL HOT	CCFL high voltage

CN11(Header): S2B-ZR-SM3A-TF(JST) or equivalent

Pin	Name	Description
1	CCFL COLD	CCFL low voltage (+)
2	CCFL COLD	CCFL low voltage (-)

Note (1) Floating of any control signal is not allowed.

5.4 BLOCK DIAGRAM OF INTERFACE

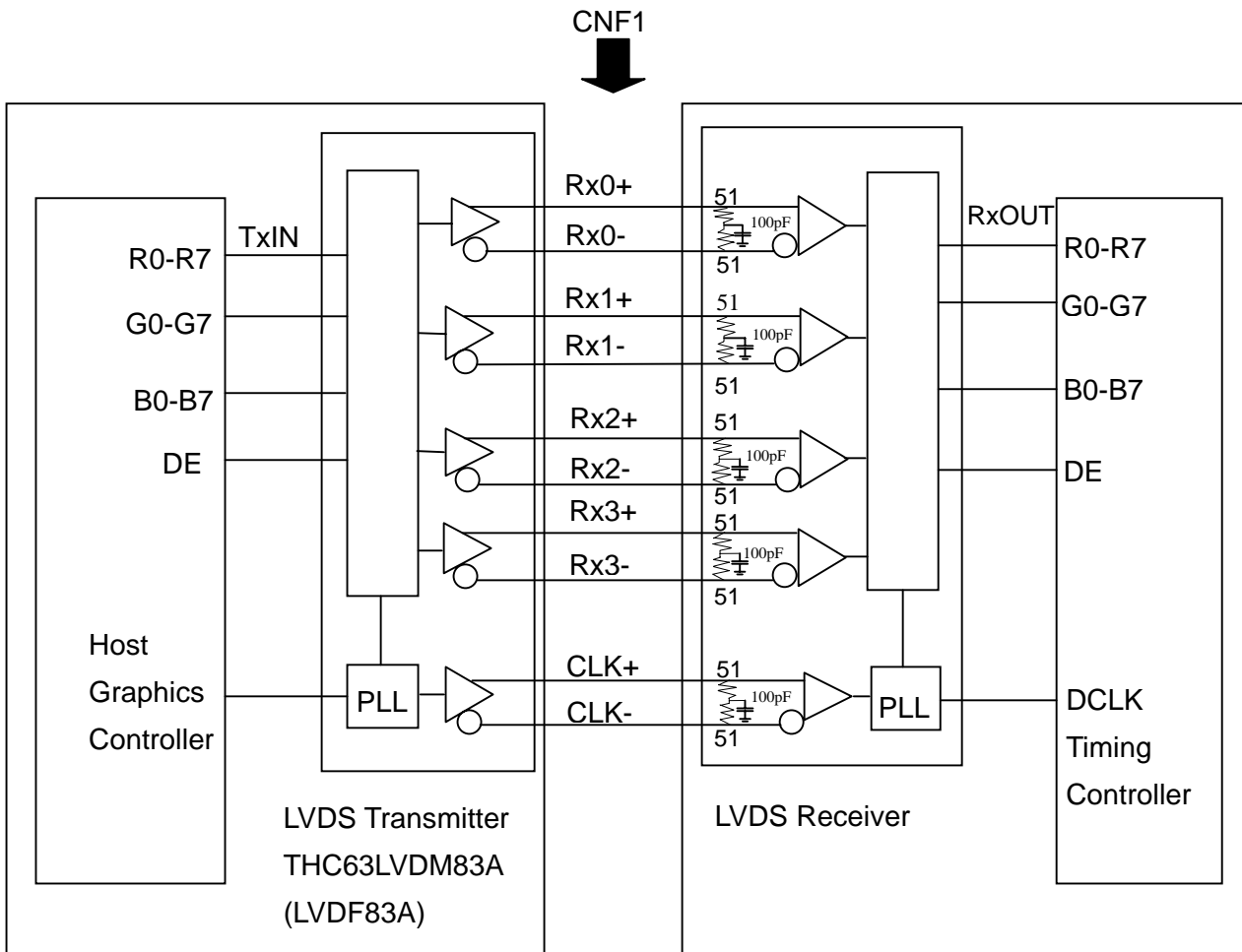

R0~R7 : Pixel R Data ,
 G0~G7 : Pixel G Data ,
 B0~B7 : Pixel B Data ,
 DE : Display timing signal

Note (1) The system must have the transmitter to drive the module.

Note (2) LVDS cable impedance shall be 50 ohms per signal line or about 100 ohms per twist-pair line when it is used differentially.

5.5 LVDS INTERFACE

	SIGNAL	TRANSMITTER THC63LVDM83A		INTERFACE CONNECTOR		RECEIVER THC63LVDF84A		TFT CONTROL
		PIN	INPUT	Host	TFT-LCD	PIN	OUTPUT	INPUT
24bit	R0	51	TxIN0			27	Rx OUT0	R0
	R1	52	TxIN1			29	Rx OUT1	R1
	R2	54	TxIN2	TA OUT0+	Rx 0+	30	Rx OUT2	R2
	R3	55	TxIN3			32	Rx OUT3	R3
	R4	56	TxIN4			33	Rx OUT4	R4
	R5	3	TxIN6	TA OUT0-	Rx 0-	35	Rx OUT6	R5
	G0	4	TxIN7			37	Rx OUT7	G0
	G1	6	TxIN8			38	Rx OUT8	G1
	G2	7	TxIN9			39	Rx OUT9	G2
	G3	11	TxIN12	TA OUT1+	Rx 1+	43	Rx OUT12	G3
	G4	12	TxIN13			45	Rx OUT13	G4
	G5	14	TxIN14			46	Rx OUT14	G5
	B0	15	TxIN15	TA OUT1-	Rx 1-	47	Rx OUT15	B0
	B1	19	TxIN18			51	Rx OUT18	B1
	B2	20	TxIN19			53	Rx OUT19	B2
	B3	22	TxIN20			54	Rx OUT20	B3
	B4	23	TxIN21	TA OUT2+	Rx 2+	55	Rx OUT21	B4
	B5	24	TxIN22			1	Rx OUT22	B5
	DE	30	TxIN26			6	Rx OUT26	DE
	R6	50	TxIN27	TA OUT2-	Rx 2-	7	Rx OUT27	R6
	R7	2	TxIN5			34	Rx OUT5	R7
	G6	8	TxIN10			41	Rx OUT10	G6
	G7	10	TxIN11			42	Rx OUT11	G7
	B6	16	TxIN16	TA OUT3+	Rx 3+	49	Rx OUT16	B6
	B7	18	TxIN17			50	Rx OUT17	B7
	RSVD 1	25	TxIN23			2	Rx OUT23	Not connect
	RSVD 2	27	TxIN24	TA OUT3-	Rx 3-	3	Rx OUT24	Not connect
	RSVD 3	28	TxIN25			5	Rx OUT25	Not connect
	DCLK	31	TxCLK IN	TxCLK OUT+ TxCLK OUT-	RxCLK IN+ RxCLK IN-	26	RxCLK OUT	DCLK

R0~R7: Pixel R Data (7; MSB, 0; LSB)

G0~G7: Pixel G Data (7; MSB, 0; LSB)

B0~B7: Pixel B Data (7; MSB, 0; LSB)

DE: Display timing signal

Notes(1) RSVD(reserved)pins on the transmitter shall be "H" or "L".

5.6 COLOR DATA INPUT ASSIGNMENT

The brightness of each primary color (red, green and blue) is based on the 8-bit gray scale data input for the color. The higher the binary input, the brighter the color. The table below provides the assignment of color versus data input.

Color		Data Signal																							
		Red								Green								Blue							
		R7	R6	R5	R4	R3	R2	R1	R0	R7	R6	G5	G4	G3	G2	G1	G0	R7	R6	B5	B4	B3	B2	B1	B0
Basic Colors	Black	0	0	0	0	0	0	0	0	0	0	0	0	0	0	0	0	0	0	0	0	0	0	0	
	Red	1	1	1	1	1	1	1	1	0	0	0	0	0	0	0	0	0	0	0	0	0	0	0	
	Green	0	0	0	0	0	0	0	0	1	1	1	1	1	1	1	0	0	0	0	0	0	0	0	
	Blue	0	0	0	0	0	0	0	0	0	0	0	0	0	0	0	1	1	1	1	1	1	1	1	
	Cyan	0	0	0	0	0	0	0	0	1	1	1	1	1	1	1	1	1	1	1	1	1	1	1	
	Magenta	1	1	1	1	1	1	1	1	0	0	0	0	0	0	0	1	1	1	1	1	1	1	1	
	Yellow	1	1	1	1	1	1	1	1	1	1	1	1	1	1	1	0	0	0	0	0	0	0	0	
	White	1	1	1	1	1	1	1	1	1	1	1	1	1	1	1	1	1	1	1	1	1	1	1	
Gray Scale Of Red	Red(0) / Dark	0	0	0	0	0	0	0	0	0	0	0	0	0	0	0	0	0	0	0	0	0	0		
	Red(1)	0	0	0	0	0	0	1	0	0	0	0	0	0	0	0	0	0	0	0	0	0	0		
	Red(2)	0	0	0	0	0	1	0	0	0	0	0	0	0	0	0	0	0	0	0	0	0	0		
	:	:	:	:	:	:	:	:	:	:	:	:	:	:	:	:	:	:	:	:	:	:	:		
	:	:	:	:	:	:	:	:	:	:	:	:	:	:	:	:	:	:	:	:	:	:	:		
	Red(253)	1	1	1	1	1	1	0	1	0	0	0	0	0	0	0	0	0	0	0	0	0	0		
	Red(254)	1	1	1	1	1	1	1	0	0	0	0	0	0	0	0	0	0	0	0	0	0	0		
	Red(255)	1	1	1	1	1	1	1	1	0	0	0	0	0	0	0	0	0	0	0	0	0	0		
Gray Scale Of Green	Green(0) / Dark	0	0	0	0	0	0	0	0	0	0	0	0	0	0	0	0	0	0	0	0	0	0		
	Green(1)	0	0	0	0	0	0	0	0	0	0	0	0	0	0	1	0	0	0	0	0	0	0		
	Green(2)	0	0	0	0	0	0	0	0	0	0	0	0	0	1	0	0	0	0	0	0	0	0		
	:	:	:	:	:	:	:	:	:	:	:	:	:	:	:	:	:	:	:	:	:	:	:		
	:	:	:	:	:	:	:	:	:	:	:	:	:	:	:	:	:	:	:	:	:	:	:		
	Green(253)	0	0	0	0	0	0	0	0	1	1	1	1	1	0	1	0	0	0	0	0	0	0		
	Green(254)	0	0	0	0	0	0	0	0	1	1	1	1	1	1	0	0	0	0	0	0	0	0		
	Green(255)	0	0	0	0	0	0	0	0	1	1	1	1	1	1	1	0	0	0	0	0	0	0		
Gray Scale Of Blue	Blue(0) / Dark	0	0	0	0	0	0	0	0	0	0	0	0	0	0	0	0	0	0	0	0	0	0		
	Blue(1)	0	0	0	0	0	0	0	0	0	0	0	0	0	0	0	0	0	0	0	0	0	1		
	Blue(2)	0	0	0	0	0	0	0	0	0	0	0	0	0	0	0	0	0	0	0	0	0	1		
	:	:	:	:	:	:	:	:	:	:	:	:	:	:	:	:	:	:	:	:	:	:	:		
	:	:	:	:	:	:	:	:	:	:	:	:	:	:	:	:	:	:	:	:	:	:	:		
	Blue(253)	0	0	0	0	0	0	0	0	0	0	0	0	0	0	0	1	1	1	1	1	1	0		
	Blue(254)	0	0	0	0	0	0	0	0	0	0	0	0	0	0	0	1	1	1	1	1	1	0		
	Blue(255)	0	0	0	0	0	0	0	0	0	0	0	0	0	0	0	1	1	1	1	1	1	1		

Note (1) 0: Low Level Voltage, 1: High Level Voltage

6. INTERFACE TIMING

6.1 INPUT SIGNAL TIMING SPECIFICATIONS

The input signal timing specifications are shown as the following table and timing diagram.

Signal	Item	Symbol	Min.	Typ.	Max.	Unit	Note
Clock	Frequency	1/Tc	(60)	86	(88)	MHz	
Vertical Active Display Term	Frame Rate	Fr	(47)	60	(63)	Hz	
	Total	Tv	(770)	795	(888)	Th	Tv=Tvd+Tvb
	Display	Tvd	768	768	768	Th	
	Blank	Tvb	(2)	27	(120)	Th	
Horizontal Active Display Term	Total	Th	(1436)	1798	(1936)	Tc	Th=Thd+Thb
	Display	Thd	1366	1366	1366	Tc	
	Blank	Thb	(70)	432	(570)	Tc	

Note (1) Since this module is operated in DE only mode, Hsync and Vsync input signals should be set to low logic level. Otherwise, this module would operate abnormally.

INPUT SIGNAL TIMING DIAGRAM

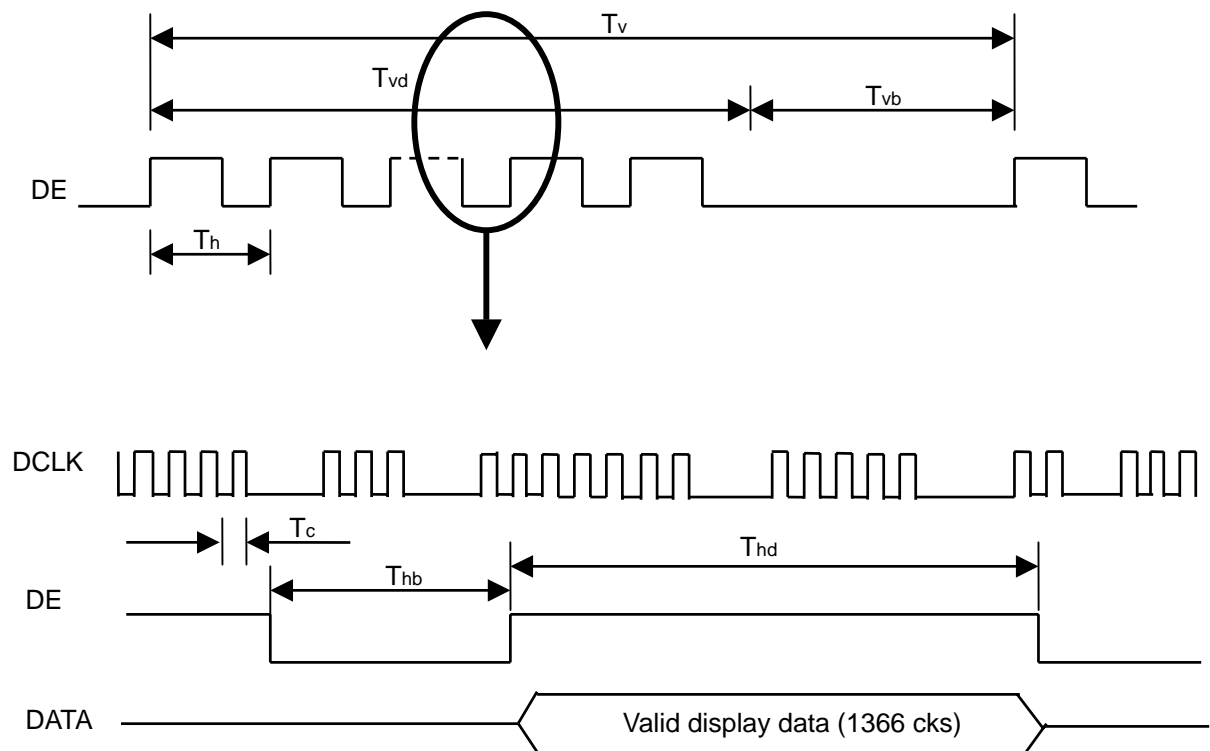

6.2 POWER ON/OFF SEQUENCE

To prevent a latch-up or DC operation of LCD module, the power on/off sequence should be as the diagram below.

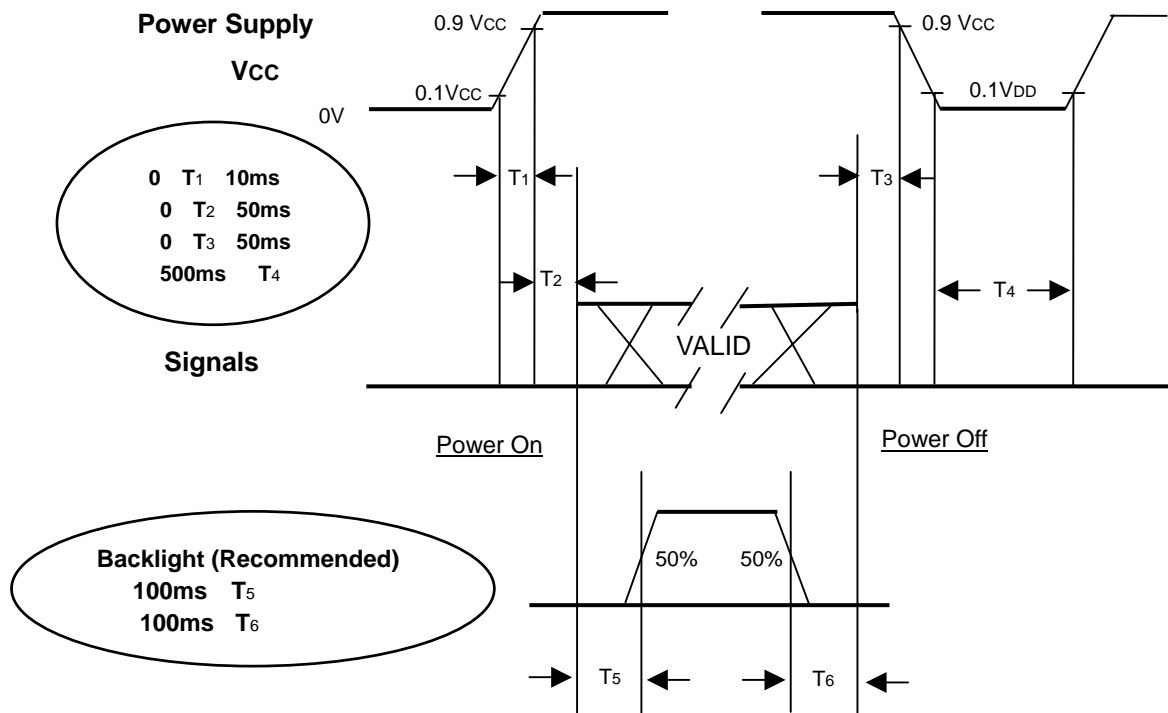

Power ON/OFF Sequence

Note (1) The supply voltage of the external system for the module input should follow the definition of Vcc.

Note (2) Apply the lamp voltage within the LCD operation range. When the backlight turns on before the LCD operation or the LCD turns off before the backlight turns off, the display may momentarily become abnormal screen.

Note (3) In case of Vcc is in off level, please keep the level of input signals on the low or high impedance.

Note (4) T4 should be measured after the module has been fully discharged between power off and on period.

Note (5) Interface signal shall not be kept at high impedance when the power is on.

7. OPTICAL CHARACTERISTICS

7.1 TEST CONDITIONS

Item	Symbol	Value	Unit
Ambient Temperature	Ta	25±2	°C
Ambient Humidity	Ha	50±10	%RH
Supply Voltage	V _{CC}	5.0	V
Input Signal	According to typical value in "3. ELECTRICAL CHARACTERISTICS"		
Lamp Current	I _L	(4.8)±0.3	mA
Oscillating Frequency (Inverter)	F _w	(60)	KHz

7.2 OPTICAL SPECIFICATIONS

The relative measurement methods of optical characteristics are shown in 7.2. The following items should be measured under the test conditions described in 7.1 and stable environment shown in Note (7).

Item	Symbol	Condition	Min.	Typ.	Max.	Unit	Note	
Contrast Ratio	CR	$\theta_x=0^\circ, \theta_y=0^\circ$ Viewing Normal Angle		(800)	-	-	Note(2)	
Response Time	T _R		-	(15)			ms	Note(3)
	T _F		-	(10)			ms	
			Gray to gray		(16.6)			ms
Center Luminance of White	L _C			(550)	-		cd/m ²	Note(5)
Average Luminance of White	L _{AVE}			(450)	-		cd/m ²	
White Variation	δW			-	-	(1.3)	-	Note(8)
Cross Talk	CT			-	-	(4.0)	%	Note(6)
Color Chromaticity	Red		R _x		(0.650)		-	9, 300K NTSC Ratio
			R _y		(0.331)		-	
	Green		G _x		(0.276)		-	
			G _y		(0.601)		-	
	Blue		B _x		(0.142)		-	
			B _y		(0.074)		-	
	White	W _x		(0.282)		-		
W _y			(0.293)		-			
	Color Gamut	CG		(75)		%		
Viewing Angle	Horizontal	θ _{x+}		(85)	-	Deg.	Note(1) No gray scale inversion	
		θ _{x-}		(85)	-			
	Vertical	θ _{y+}	CR≥10		(85)			-
		θ _{y-}			(85)			-

Note (1) Definition of Viewing Angle (θ_x, θ_y):

Viewing angles are measured by EZ-Contrast 160R (Eldim)

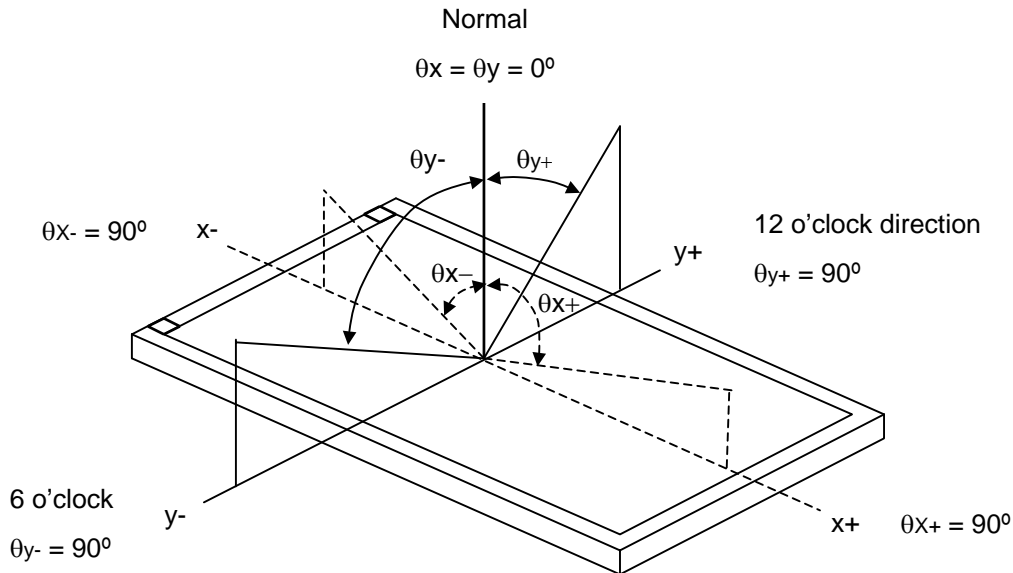

Note (2) Definition of Contrast Ratio (CR):

The contrast ratio can be calculated by the following expression.

$$\text{Contrast Ratio (CR)} = L_{255} / L_0$$

L255: Luminance of gray level 255

L 0: Luminance of gray level 0

$$\text{CR} = \text{CR} (5)$$

CR (X) is corresponding to the Contrast Ratio of the point X at the figure in Note (8).

Note (3) Definition of Response Time (T_R, T_F):

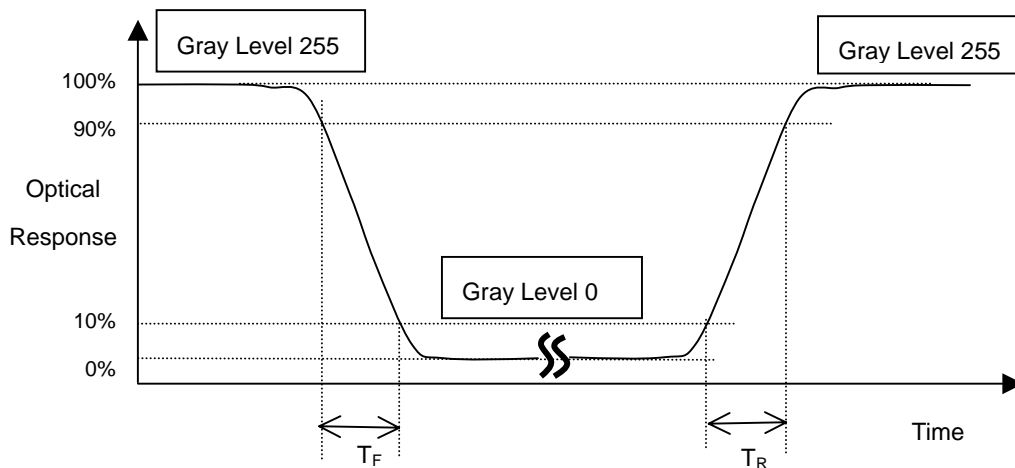

Note (4) Definition of Gray to Gray Switching Time:

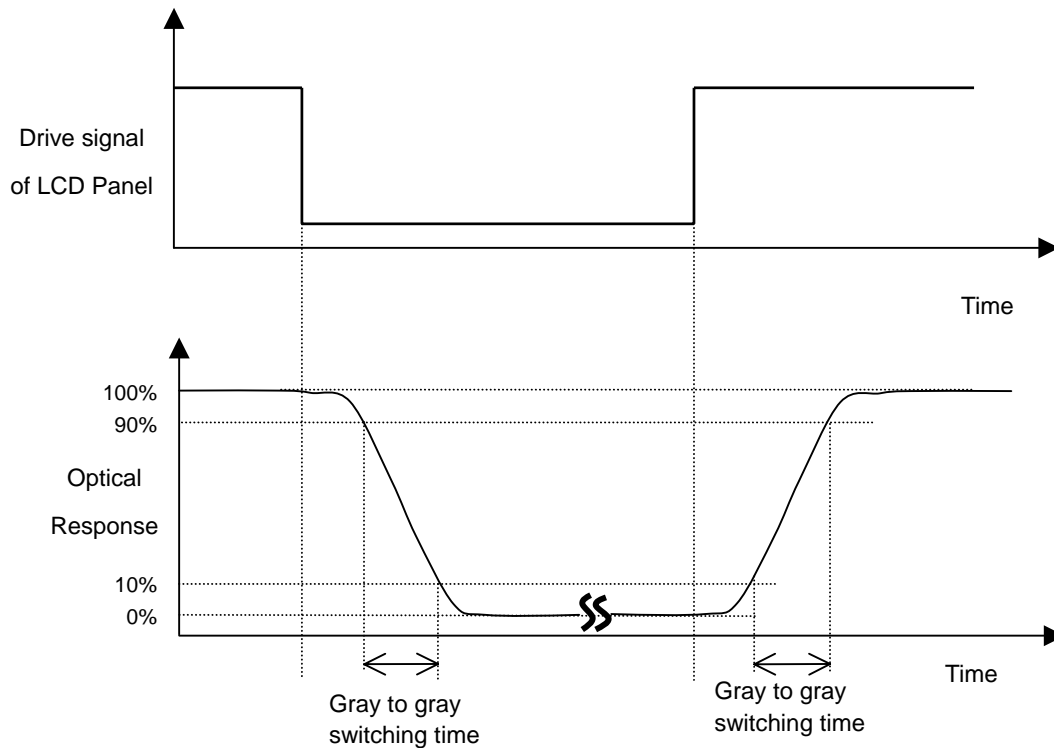

The driving signal means the signal of gray level 0, 63, 127, 191, 255.

Note (5) Definition of Luminance of White (L_C , L_{AVE}):

Measure the luminance of gray level 255 at center point and 5 points

$$L_C = L(5)$$

$$L_{AVE} = [L(1) + L(2) + L(3) + L(4) + L(5)] / 5$$

$L(x)$ is corresponding to the luminance of the point X at the figure in Note (8).

Note (6) Definition of Cross Talk (CT):

$$CT = |Y_B - Y_A| / Y_A \times 100 (\%)$$

Where:

Y_A = Luminance of measured location without gray level 0 pattern (cd/m^2)

Y_B = Luminance of measured location with gray level 0 pattern (cd/m^2)

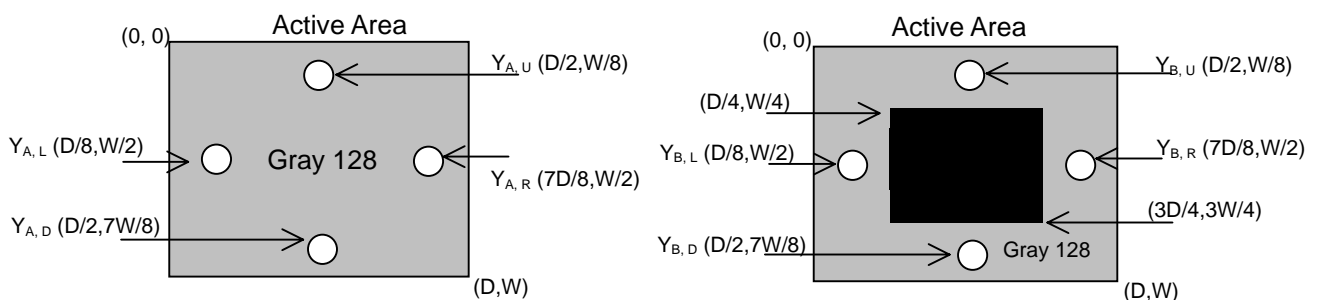

Note (7) Measurement Setup:

The LCD module should be stabilized at given temperature for 1 hour to avoid abrupt temperature change during measuring. In order to stabilize the luminance, the measurement should be executed after lighting Backlight for 1 hour in a windless room.

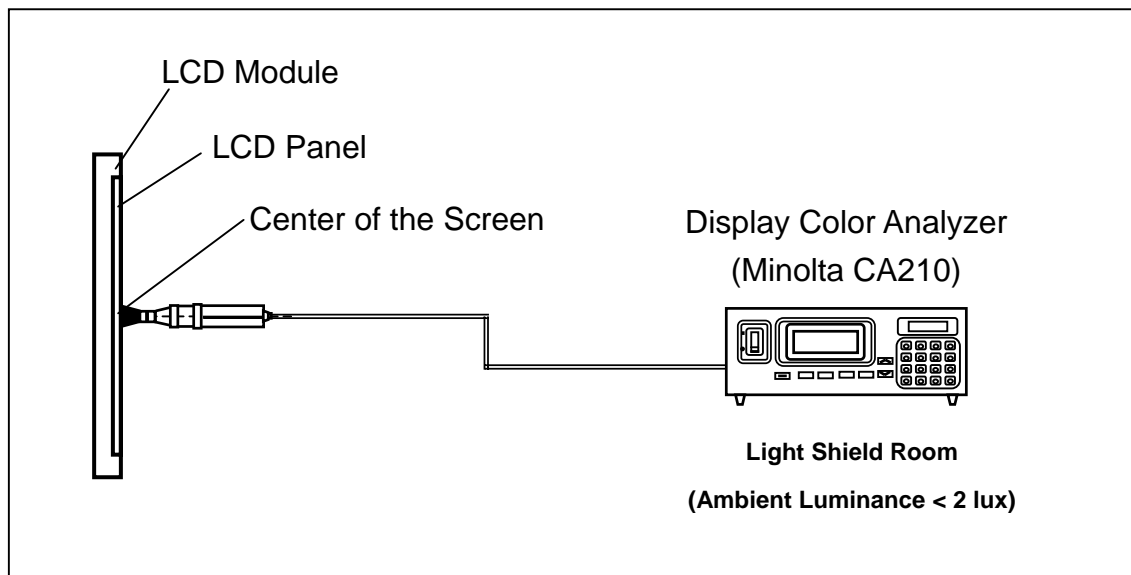

Note (8) Definition of White Variation (δW):

Measure the luminance of gray level 255 at 5 points

$$\delta W = \text{Maximum} [L (1), L (2), L (3), L (4), L (5)] / \text{Minimum} [L (1), L (2), L (3), L (4), L (5)]$$

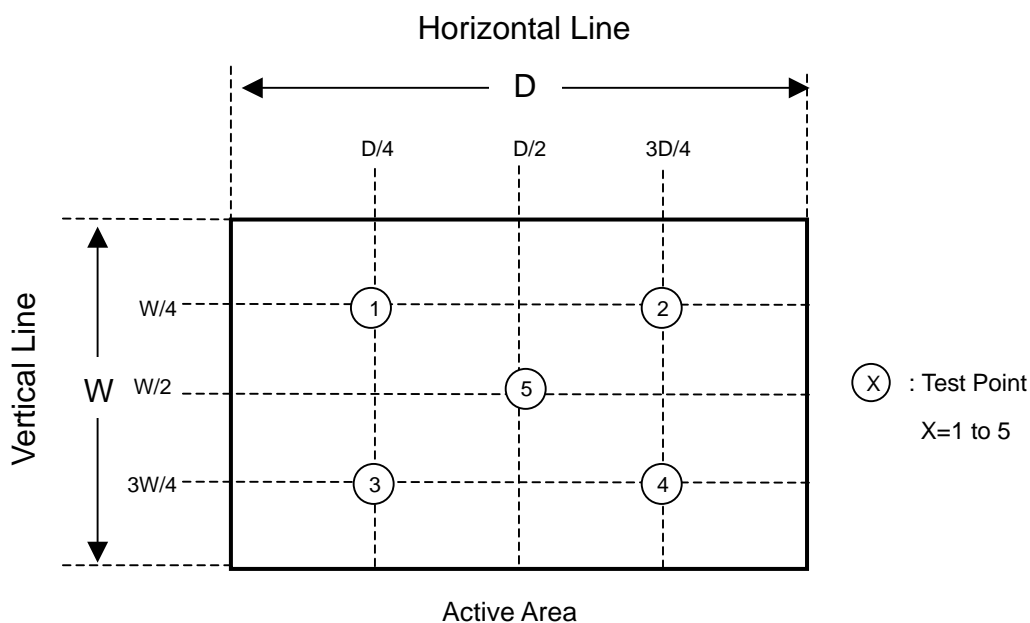

8. PRECAUTIONS

8.1 ASSEMBLY AND HANDLING PRECAUTIONS

- (1) Do not apply rough force such as bending or twisting to the module during assembly.
- (2) It is recommended to assemble or to install a module into the user's system in clean working areas.
The dust and oil may cause electrical short or worsen the polarizer.
- (3) Do not apply pressure or impulse to the module to prevent the damage of LCD panel and Backlight.
- (4) Always follow the correct power-on sequence when the LCD module is turned on. This can prevent the damage and latch-up of the CMOS LSI chips.
- (5) Do not plug in or pull out the I/F connector while the module is in operation.
- (6) Do not disassemble the module.
- (7) Use a soft dry cloth without chemicals for cleaning, because the surface of polarizer is very soft and easily scratched.
- (8) Moisture can easily penetrate into LCD module and may cause the damage during operation.
- (9) High temperature or humidity may deteriorate the performance of LCD module. Please store LCD modules in the specified storage conditions.
- (10) When ambient temperature is lower than 10°C, the display quality might be reduced. For example, the response time will become slow, and the starting voltage of CCFL will be higher than that of room temperature.

8.2 SAFETY PRECAUTIONS

- (1) The startup voltage of a Backlight is approximately 1000 Volts. It may cause an electrical shock while assembling with the inverter. Do not disassemble the module or insert anything into the Backlight unit.
- (2) If the liquid crystal material leaks from the panel, it should be kept away from the eyes or mouth. In case of contact with hands, skin or clothes, it has to be washed away thoroughly with soap.
- (3) After the module's end of life, it is not harmful in case of normal operation and storage.

9. MECHANICAL CHARACTERISTICS

