

HITACHI

Hitachi Displays, Ltd.

Date ; Nov. 11 ,2003

TECHNICAL DATA

TX38D90VC1CAN

CONTENTS

No.	Item	Sheet No.	Page
—	COVER	3284TTD 1553-1	1-1/1
—	RECORD OF REVISION	3284TTD 1553-1	2-1/1
—	APPLICATION	3284TTD 1553-1	3-1/1
1	ABSOLUTE MAXIMUM RATING	3284TTD 1553-1	4-1/2~2/2
2	OPTICAL CHARACTERISTICS	3284TTD 1553-1	5-1/2~2/2
3	ELECTRICAL CHARACTERISTICS	3284TTD 1553-1	6-1/1
4	BLOCK DIAGRAM	3284TTD 1553-1	7-1/1
5	INTERFACE PIN CONNECTION	3284TTD 1553-1	8-1/5~5/5
6	INTERFACE TIMING FOR LVDS TRANSMITTER	3284TTD 1553-1	9-1/4~4/4
7	DIMENSIONAL OUTLINE	3284TTD 1553-1	10-1/1
8	DISIGNATION OF LOT MARK	3284TTD 1553-1	11-1/2~2/2
9	PRECAUTIONS	3284TTD 1553-1	12-1/4~4/4

Hitachi Displays, Ltd.	Sh. No.	3284TTD 1553-1	Page	1-1/1
------------------------	------------	----------------	------	-------

RECORD OF REVISION

Date	Old Sheet No.	Summary
	New Sheet No.	

S C O P E

This specification is applied to the following TFT Liquid Crystal Display Module with Back-light unit.

Note : Inverter device for Back-light is not built in and so it needs to be prepared on yours side.

- Type name : TX38D90VC1CAN
- Display Area : H304.5×V228.375 [mm]
- Display Dots : H(1400×3)×V1050 [dots]
(Display Pixels) (H1400×V1050 pixels)
- Voltage of V_{DD} : 3.3V
- Pixel Pitch : H0.2175×V0.2175
- Color Pixel Arrangement : R·G·B Vertical Stripe
- Display Mode : Transmissive &
Normally White Mode
- Color Number : 262k Colors
- Direction with Wider Viewing Angle : Lower side of 6 o'clock
(Azimuth $\phi=270^\circ$)
- Dimensions Outlines : 315(W)×240(H)×6.8MAX(T) [mm]
- Weight : Approximately 550 [g]
- Interface : 2ch-LVDS
- Surface Polarizing Film : Polarizing Film with Antiglare Coating
- Back-light : One Cold Cathode Florescent Lamp
(Lower side)
Back-light inverter is not contained in Module.

Hitachi, Ltd.	Date	Jul. 24, 2001	Sh. No.	3284TTD 1553-1	Page	3-1/1
---------------	------	---------------	------------	----------------	------	-------

1. ABSOLUTE MAXIMUM RATINGS

1.1 ENVIRONMENTAL ABSOLUTE MAXIMUM RATINGS

ITEM	OPERATING		STORAGE		UNIT	NOTE
	MIN.	MAX.	MIN.	MAX.		
Ambient Temperature	0	40	-20	60	°C	1)
Humidity	2)		2)		%RH	1)
Vibration	—	4.9 (0.5G)	—	19.6 (2G)	m/s ²	3), 5)
Shock	—	29.4 (3G)	—	490 (50G)		4), 5)
Corrosive Gas	NOT ACCEPTABLE		NOT ACCEPTABLE		—	
Illuminance at LCD surface	—	50,000	—	50,000	lx	

Note 1) Environmental temperature and humidity of this unit, not of system installed with this unit.

At low temperature the brightness of CFL drop and the life time of CFL become to be short.

2) Ambient temp. $T_a \leq 40^\circ\text{C}$: 85%RH MAX. without condensation
 $T_a > 40^\circ\text{C}$: Absolute humidity must be lower than the saturated vapor of 85%RH at 40°C . without condensation

3) Vibration frequency : 20~50Hz. (Except resonance frequency)

4) 7ms of pulse width.

5) With mounting protective spacer (ref. page 4-2/2)

1.2 ELECTRICAL ABSOLUTE MAXIMUM RATINGS

(1) TFT LIQUID CRYSTAL DISPLAY MODULE

$V_{SS}=0V$

ITEM	SYMBOL	MIN.	MAX.	UNIT	NOTE
Power Supply Voltage	VDD	0	4.0	V	
Electrostatic Durability	VESD0	±100		v	1), 2)
	VESD1	± 8		kV	1), 3)

Note 1) Discharge circuit : 200pF-250Ω, Surrounding : 25°C-70%RH.

2) The specification is applicable to I/F Connector pins.

3) The specification is applicable to metal bezel and LCD glass.

(2) BACK-LIGHT UNIT

$GND=0V$

ITEM	SYMBOL	MIN.	MAX.	UNIT	NOTE
Lamp Current	IL	0	7.0	mArms	1)
Lamp Voltage	VL	0	2000	Vrms	

Note 1) At Lamp start-up time.

Adding protective spacer at shock & vibration test

Shaded area is to be supported with additional spacer.

- (1) This protective spacer is to be added at shock and vibration test on the front side

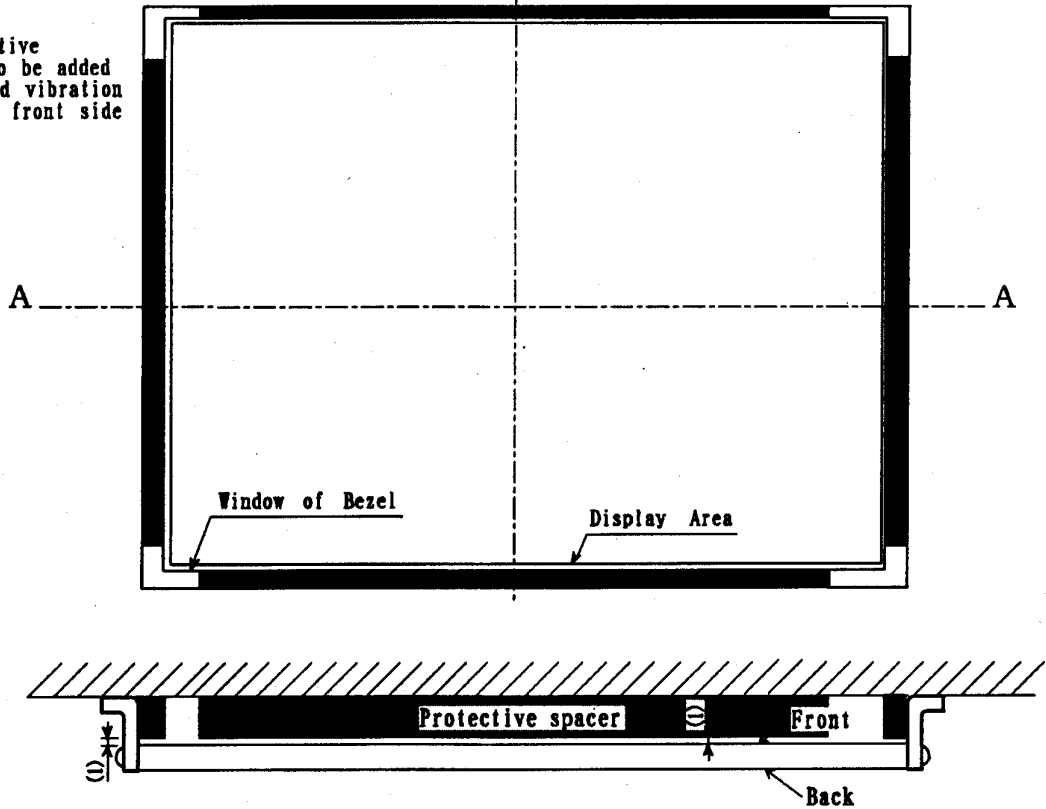

Shaded area is to be supported with additional spacer.

- (2) This protective spacer is to be added shock and vibration test on the back side

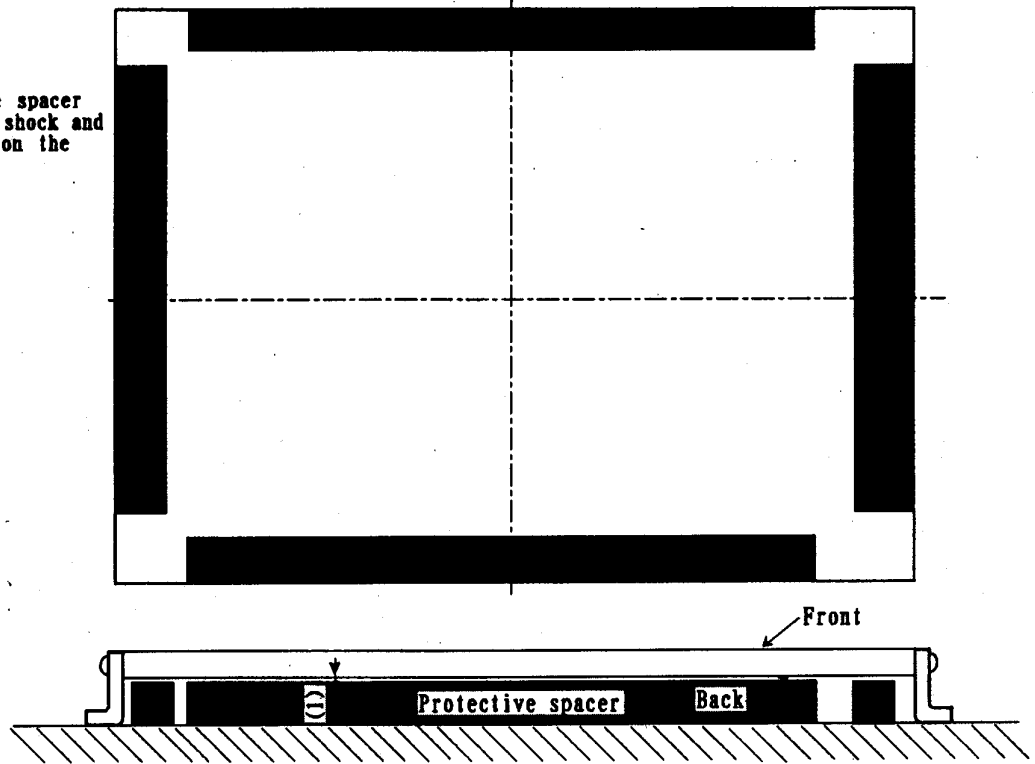

2. OPTICAL CHARACTERISTICS

The following items are measured on the conditions that this unit operation (TFT panel and Back-light) and measuring systems are stable.

The ambient light excluding The Back-light unit is nothing.

- Measuring equipment : TOPCON BM-7, Prichard 1980B, or equivalent
- Measuring point : Active area center

Temperature of LCD=25°C, V_{DD}=3.3V, f_v=60Hz, I_L=6mA,
Back-Light operation Frequency=50kHz

ITEM	SYMBOL	CONDITION	MIN.	TYP.	MAX.	UNIT	NOTE	
Contrast Ratio	CR	$\theta = 0^\circ$ Note 1)	100	—	—	—	2)	
Response Time	RISE		tr	—	37	—	ms	3)
	FALL		tf	—	20	—		
Brightness (White)	Bwh		100	150	—	cd/m ²		
Color of CIE	Red		x	—	0.59	—	—	
			y	—	0.33	—		
	Green		x	—	0.30	—		
			y	—	0.56	—		
	Blue		x	—	0.14	—		
			y	—	0.13	—		
	White	x	—	0.31	—			
		y	—	0.33	—			

Note 1) Definition of Viewing Angle

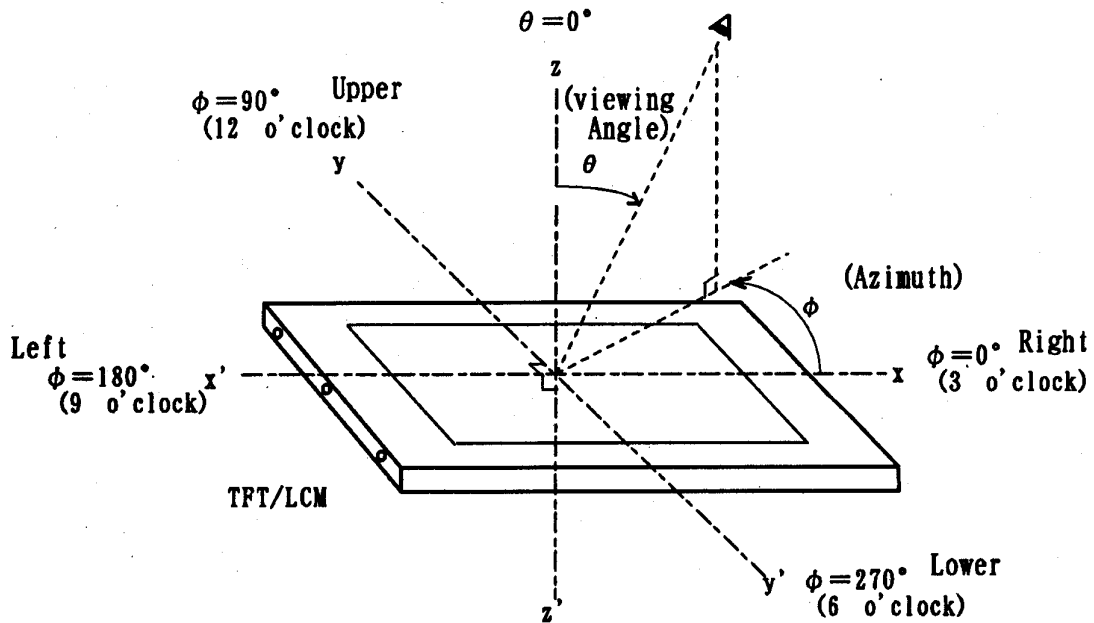

Note 2) Definition of Contrast Ratio (CR)

$$CR = \frac{\text{Brightness when displaying White raster}}{\text{Brightness when displaying Black raster}}$$

These Brightness is measured on the center of screen.

* Measurement in the darkroom.

Note 3) Definition of Response Time

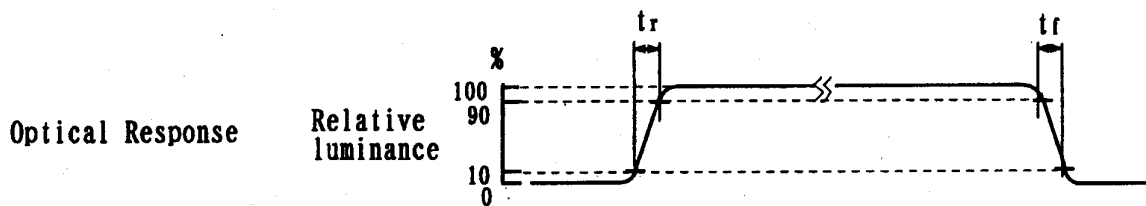

1. ELECTRICAL CHARACTERISTICS

(1) TFT LIQUID CRYSTAL DISPLAY MODULE

Ta=25°C, Vss=0V

ITEM	SYMBOL	MIN.	TYP.	MAX.	UNIT	NOTE
Power Supply Voltage	VDD	3.0	3.3	3.6	V	
Differential Input Voltage for LVDS Receiver Threshold	Hi	V _{IH}	—	—	+100	1)
	Lo	V _{IL}	-100	—	—	
Power Supply Current	I _{DD}	—	500	800	mA	2), 3)
Vsync Frequency	f _v	—	60	65	Hz	4)
Hsync Frequency	f _H	—	61	76	kHz	4)
DCLK Frequency	f _{CLK}	51	54	57	MHz	4)

Note 1) Common Mode Voltage V_{CM}=+1.25V

2) f_v=60Hz, f_{CLK}=54MHz, VDD=3.3V, DC Current is measured with the method as below.

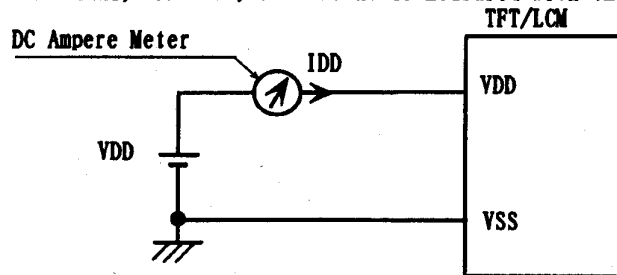

Typical value is measured when displaying vertical with 63th gray scale. Maximum is measured when displaying Vertical-stripe(Black-7 Gray scale)

- 3) Current capacity for VDD power supply should be larger than 3A, so that the fuse built in the unit(Maximum) could appropriately work in the abnormal.
4) For LVDS Transmitter Input.

(2) BACK-LIGHT UNIT

Ta=25°C

ITEM	SYMBOL	MIN.	TYP.	MAX.	UNIT	NOTE	
Lamp Current	I _L	4.0	—	6.0	mArms	1), 2), 5)	
		—	—	10	mA0-peak		
Lamp Voltage	V _L	—	690	—	Vrms		
Frequency	f _L	40	50	70	kHz	3)	
Starting Lamp Voltage	V _s	Ta=25°C	1100	—	—	Vrms	4), 6)
		Ta=0°C	1600	—	—		4), 6)

NOTE 1) Higher I_L cause the short life time of CFL.

2) DC current cause irregular fluorescence and the short life of CFL.

3) Lamp operation frequency may produce interference with Hsync frequency, which causes rolling or flickering screen. Therefore lamp operation frequency shall be as different as possible from Hsync frequency, to avoid interference.

4) Lamp start-up voltage should be more than V_s(min)

5) Reducing Lamp current increases Lamp voltage and generally increases Lamp operation frequency.

CFL inverter should be designed with taking account of minimizing the leakage current from the high-voltage output.

6) Must be high considering to the loss of the ballast capacitor in the inverter.

4. BLOCK DIAGRAM

(1) TFT LIQUID CRYSTAL DISPLAY MODULE

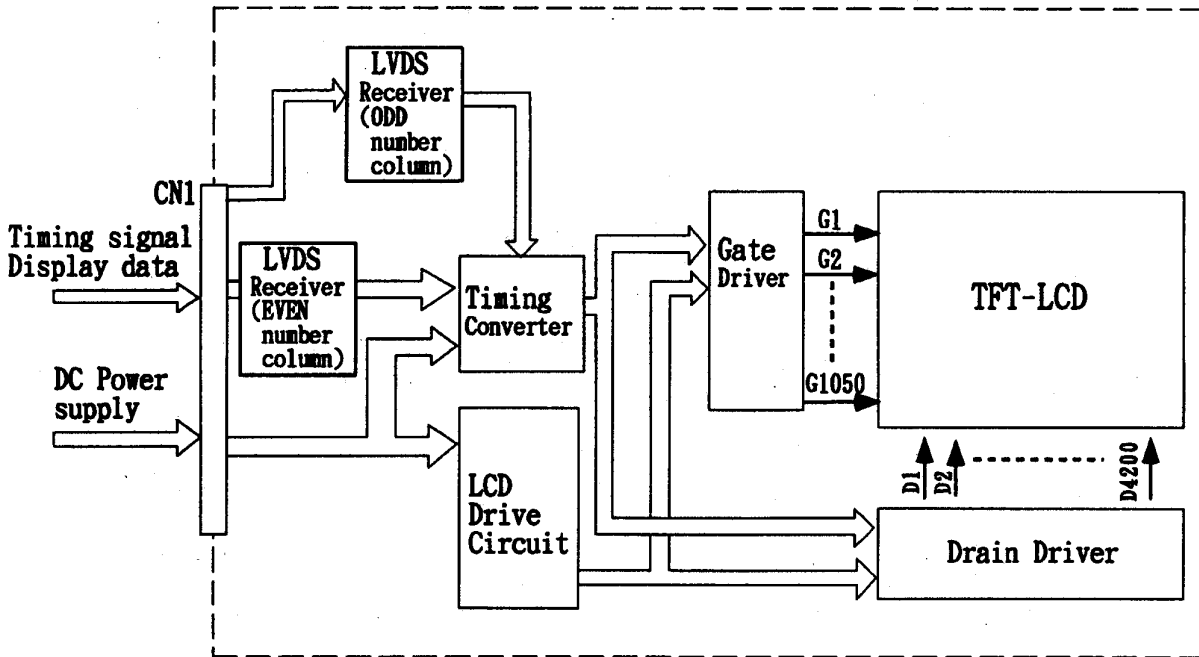

(2) BACK-LIGHT UNIT

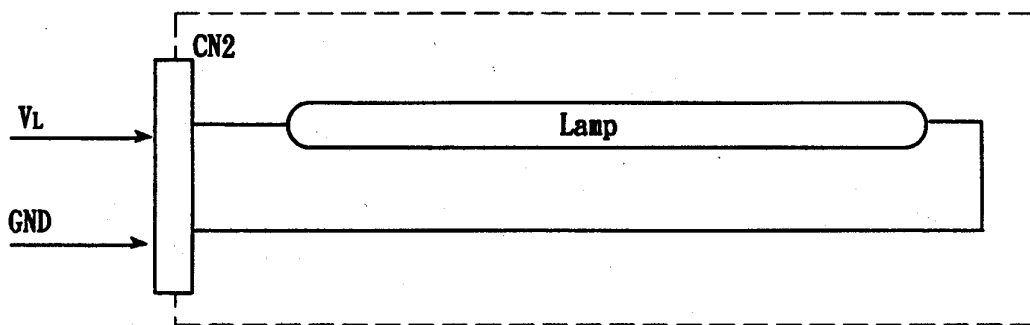

5. INTERFACE PIN CONNECTION

(1) TFT LIQUID CRYSTAL DISPLAY MODULE

CN1 《JAE FI-SEB20P-HF-A or Compatible》

Pin No	SYMBOL	FUNCTION	NOTE
1	VDD	Power Supply 3.3V nominal	2)
2	VDD	Power Supply 3.3V nominal	2)
3	VSS	Ground	1)
4	VSS	Ground	1)
5	R1in0-	LVDS Differential Data INPUT (-) for Odd	
6	R1in0+	LVDS Differential Data INPUT (+) for Odd	
7	R1in1-	LVDS Differential Data INPUT (-) for Odd	
8	R1in1+	LVDS Differential Data INPUT (+) for Odd	
9	R1in2-	LVDS Differential Data INPUT (-) for Odd	
10	R1in2+	LVDS Differential Data INPUT (+) for Odd	
11	R1CLK-	LVDS Differential Clock INPUT (-) for Odd	
12	R1CLK+	LVDS Differential Clock INPUT (+) for Odd	
13	R2in0-	LVDS Differential Data INPUT (-) for Even	
14	R2in0+	LVDS Differential Data INPUT (+) for Even	
15	R2in1-	LVDS Differential Data INPUT (-) for Even	
16	R2in1+	LVDS Differential Data INPUT (+) for Even	
17	R2in2-	LVDS Differential Data INPUT (-) for Even	
18	R2in2+	LVDS Differential Data INPUT (+) for Even	
19	R2CLK-	LVDS Differential Clock INPUT (-) for Even	
20	R2CLK+	LVDS Differential Clock INPUT (+) for Even	

Note 1) All Vss pins should be connected to GND(0V).

Metal bezel is connected internally to Vss.

2) All VDD pins should be connected to +3.3V.

(2) BACK-LIGHT UNIT

CN2 《JST BHSR-02VS-1》

Pin No	SYMBOL	DESCRIPTION
1	V _L	Power Supply
2	GND	GND (0V)

LVDS INTERFACE

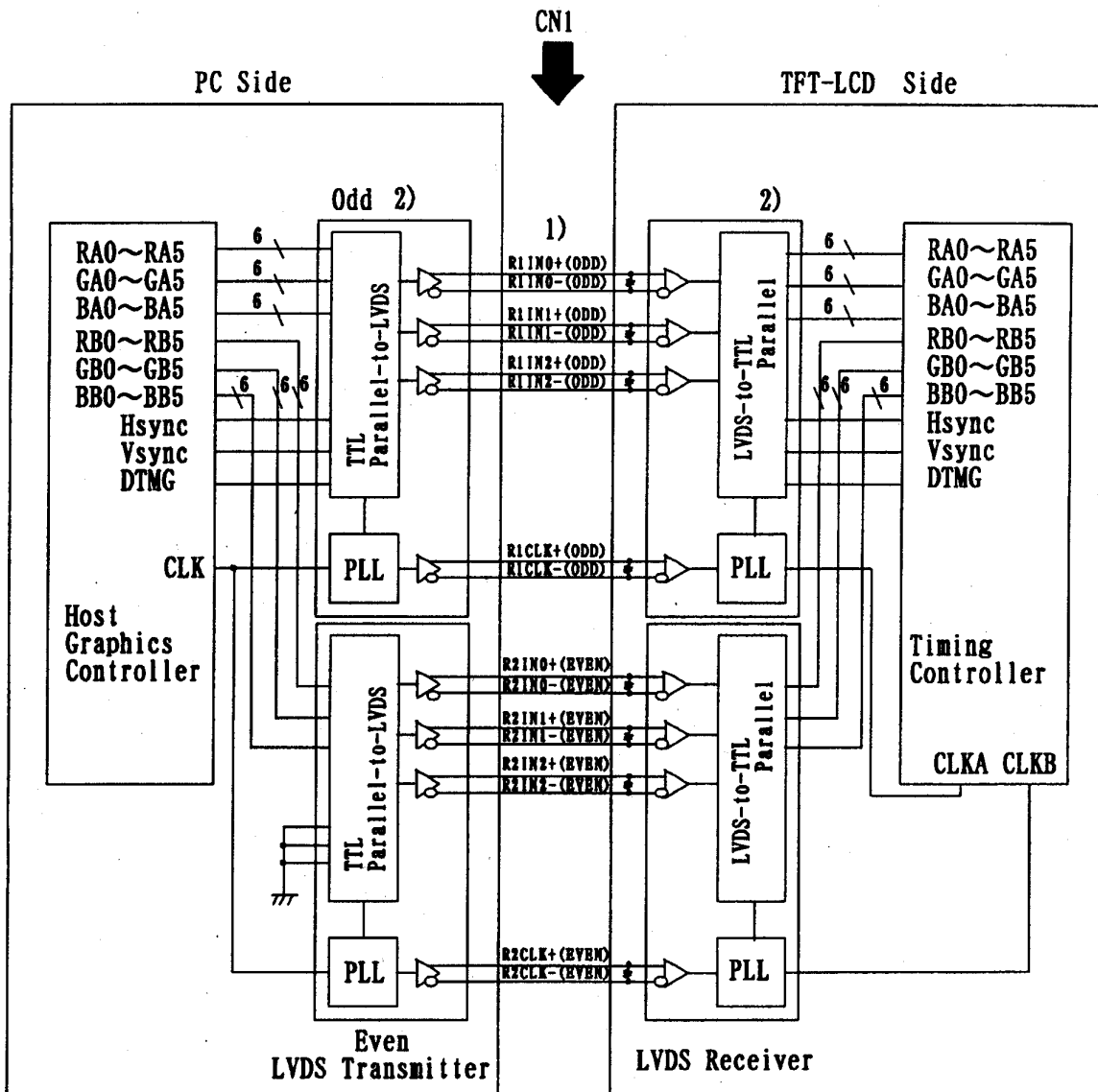

- NOTE:
- 1) LVDS cable impedance should be 100 ohms per signal line when each 2-lines(+, -) is used in differential mode.
 - 2) LVDS transmitter is not contained in the Module.
 - 3) Odd data : RA0~RA5, GAO~GA5, BAO~BA5, Hsync, Vsync, DTMG
Even data ; RBO~RB5, GAO~GA5, BBO~BB5, Vss, Vss, Vss

LVDS INPUT SIGNAL

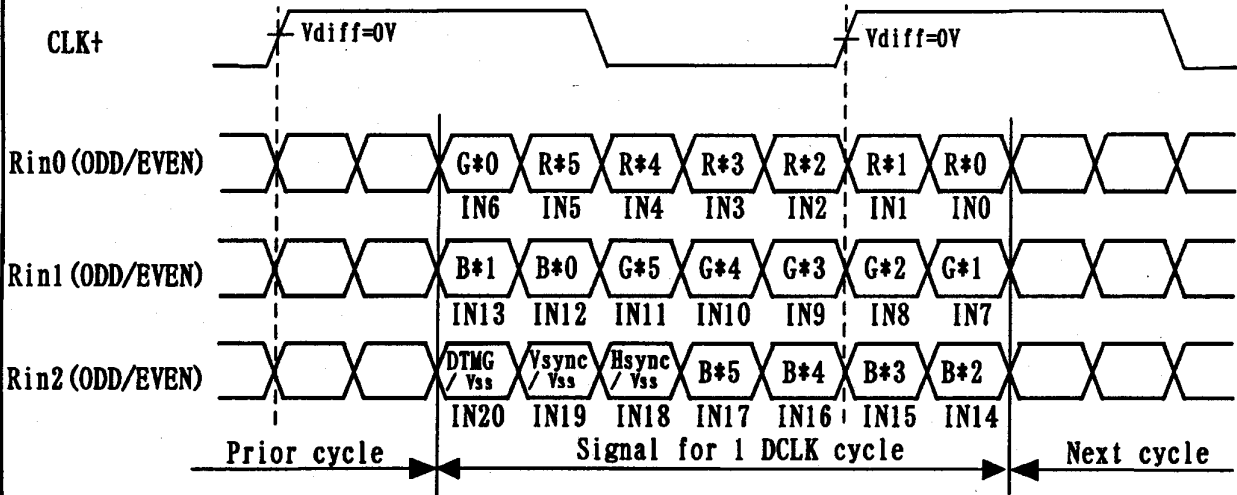

Pin connection in case of using
TI SN75LVDS84
Odd Data

Graphic Controller output	Transmitter SN75LVDS84
DCLK	CLK IN(26)
RA0	IN0(44)
RA1	IN1(45)
RA2	IN2(47)
RA3	IN3(48)
RA4	IN4(1)
RA5	IN5(3)
GA0	IN6(4)
GA1	IN7(6)
GA2	IN8(7)
GA3	IN9(9)
GA4	IN(10)
GA5	IN11(12)
BA0	IN12(13)
BA1	IN13(15)
BA2	IN14(16)
BA3	IN15(18)
BA4	IN16(19)
BA5	IN17(20)
Hsync	IN18(22)
Vsync	IN19(23)
DTMG	IN20(25)

EVEN

Graphic Controller output	Transmitter SN75LVDS84
DCLK	CLK IN(26)
RB0	IN0(44)
RB1	IN1(45)
RB2	IN2(47)
RB3	IN3(48)
RB4	IN4(1)
RB5	IN5(3)
GB0	IN6(4)
GB1	IN7(6)
GB2	IN8(7)
GB3	IN9(9)
GB4	IN(10)
GB5	IN11(12)
BB0	IN12(13)
BB1	IN13(15)
BB2	IN14(16)
BB3	IN15(18)
BB4	IN16(19)
BB5	IN17(20)
Vss	IN18(22)
Vss	IN19(23)
Vss	IN20(25)

- 1) () indicate pin NO (IC).
- 2) Even IN18~20 are connected to Vss

CORRESPONDENCE BETWEEN INPUT DATA AND

SCREEN IMAGE FOR LVDS TRANSMITTER

Display data of each adjacent two pixels are latched during one cycle of DCLK.

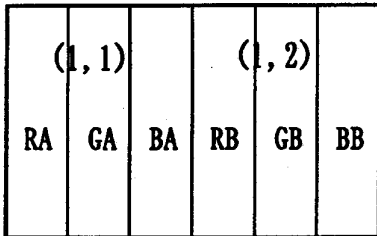

First Pixel Data : RA0~RA5, GA0~GA5, BA0~BA5
 Second Pixel Data : RB0~RB5, GB0~GB5, BB0~BB5

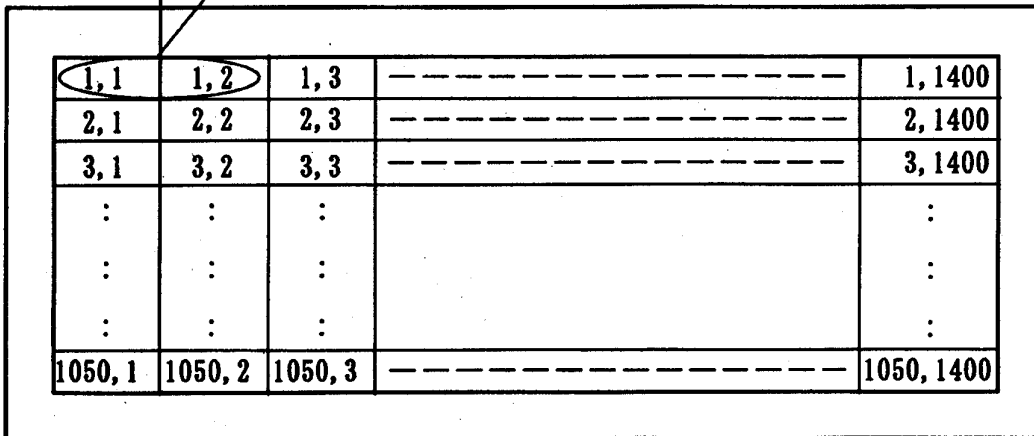

Location of screen corresponding to each input data

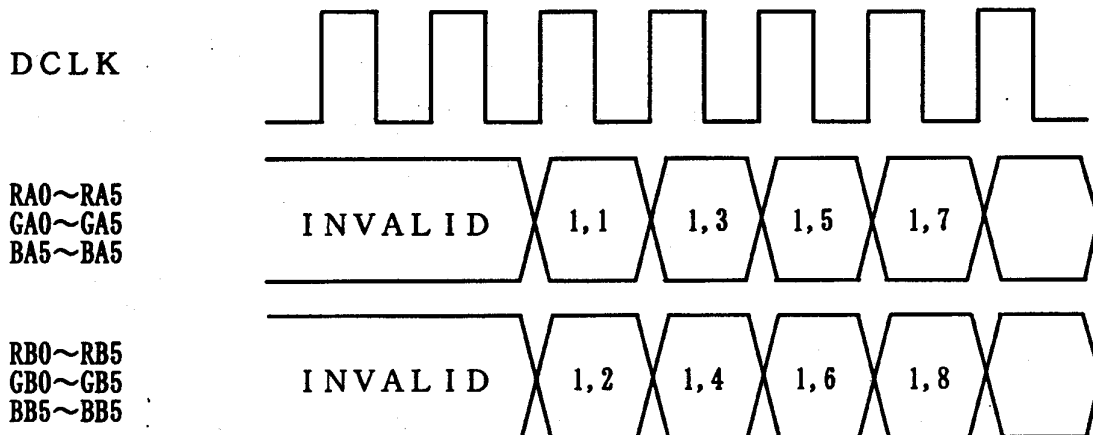

**RELATIONSHIP BETWEEN DISPLAYED COLOR
AND INPUT DATA**

INPUT DATA COLOR		R DATA						G DATA						B DATA						
		R5	R4	R3	R2	R1	R0	G5	G4	G3	G2	G1	G0	B5	B4	B3	B2	B1	B0	
		MSB					LSB	MSB					LSB	MSB					LSB	
BASIC COLOR	BLACK	0	0	0	0	0	0	0	0	0	0	0	0	0	0	0	0	0	0	0
	RED(63)	1	1	1	1	1	1	0	0	0	0	0	0	0	0	0	0	0	0	0
	GREEN(63)	0	0	0	0	0	0	1	1	1	1	1	1	0	0	0	0	0	0	0
	BLUE(63)	0	0	0	0	0	0	0	0	0	0	0	0	1	1	1	1	1	1	1
	CYAN	0	0	0	0	0	0	1	1	1	1	1	1	1	1	1	1	1	1	1
	MAGENTA	1	1	1	1	1	1	0	0	0	0	0	0	0	0	0	0	0	0	0
	YELLOW	1	1	1	1	1	1	1	1	1	1	1	1	0	0	0	0	0	0	0
	WHITE	1	1	1	1	1	1	1	1	1	1	1	1	1	1	1	1	1	1	1
RED	BLACK	0	0	0	0	0	0	0	0	0	0	0	0	0	0	0	0	0	0	0
	RED(1)	0	0	0	0	0	1	0	0	0	0	0	0	0	0	0	0	0	0	0
	RED(2)	0	0	0	0	1	0	0	0	0	0	0	0	0	0	0	0	0	0	0

	RED(61)	1	1	1	1	0	1	0	0	0	0	0	0	0	0	0	0	0	0	0
	RED(62)	1	1	1	1	1	0	0	0	0	0	0	0	0	0	0	0	0	0	0
RED(63)	1	1	1	1	1	1	0	0	0	0	0	0	0	0	0	0	0	0	0	
GREEN	BLACK	0	0	0	0	0	0	0	0	0	0	0	0	0	0	0	0	0	0	0
	GREEN(1)	0	0	0	0	0	0	0	0	0	0	1	0	0	0	0	0	0	0	0
	GREEN(2)	0	0	0	0	0	0	0	0	0	1	0	0	0	0	0	0	0	0	0

	GREEN(61)	0	0	0	0	0	0	1	1	1	1	0	1	0	0	0	0	0	0	0
	GREEN(62)	0	0	0	0	0	0	1	1	1	1	1	0	0	0	0	0	0	0	0
GREEN(63)	0	0	0	0	0	0	1	1	1	1	1	1	0	0	0	0	0	0	0	
BLUE	BLACK	0	0	0	0	0	0	0	0	0	0	0	0	0	0	0	0	0	0	0
	BLUE(1)	0	0	0	0	0	0	0	0	0	0	0	0	0	0	0	0	0	1	0
	BLUE(2)	0	0	0	0	0	0	0	0	0	0	0	0	0	0	0	0	0	1	0

	BLUE(61)	0	0	0	0	0	0	0	0	0	0	0	0	1	1	1	1	0	1	0
	BLUE(62)	0	0	0	0	0	0	0	0	0	0	0	0	1	1	1	1	1	0	0
BLUE(63)	0	0	0	0	0	0	0	0	0	0	0	0	1	1	1	1	1	1	1	

- Note 1) Definition of gray scale :
 Color(n) --- number in parenthesis indicates gray scale level.
 Larger number corresponds to brighter level.
- 2) Data : 1:High, 0:Low

6. Interface timing

(1) LVDS receiver timing (Interface of TFT module)

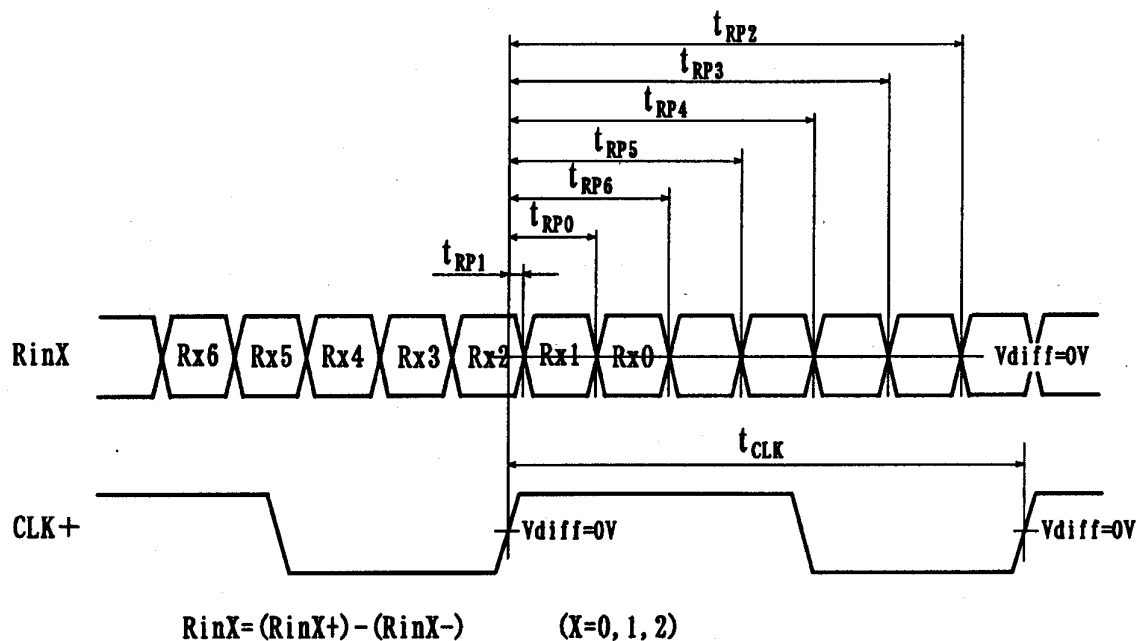

ITEM	SYMBOL	MIN.	TYP.	MAX.	UNIT	NOTE
DCLK	Frequency	$1/t_{CLK}$	51	54	57	MHz
RinX (X=0, 1, 2)	0 data position	t_{RP0}	$\frac{1}{7}t_{CLK}-0.49$	$\frac{1}{7}t_{CLK}$	$\frac{1}{7}t_{CLK}+0.49$	ns
	1st data position	t_{RP1}	-0.49	0	+0.49	
	2nd data position	t_{RP2}	$\frac{6}{7}t_{CLK}-0.49$	$\frac{6}{7}t_{CLK}$	$\frac{6}{7}t_{CLK}+0.49$	
	3rd data position	t_{RP3}	$\frac{5}{7}t_{CLK}-0.49$	$\frac{5}{7}t_{CLK}$	$\frac{5}{7}t_{CLK}+0.49$	
	4th data position	t_{RP4}	$\frac{4}{7}t_{CLK}-0.49$	$\frac{4}{7}t_{CLK}$	$\frac{4}{7}t_{CLK}+0.49$	
	5th data position	t_{RP5}	$\frac{3}{7}t_{CLK}-0.49$	$\frac{3}{7}t_{CLK}$	$\frac{3}{7}t_{CLK}+0.49$	
	6th data position	t_{RP6}	$\frac{2}{7}t_{CLK}-0.49$	$\frac{2}{7}t_{CLK}$	$\frac{2}{7}t_{CLK}+0.49$	

(2) timing converter timing
 (Input timing for transmitter)

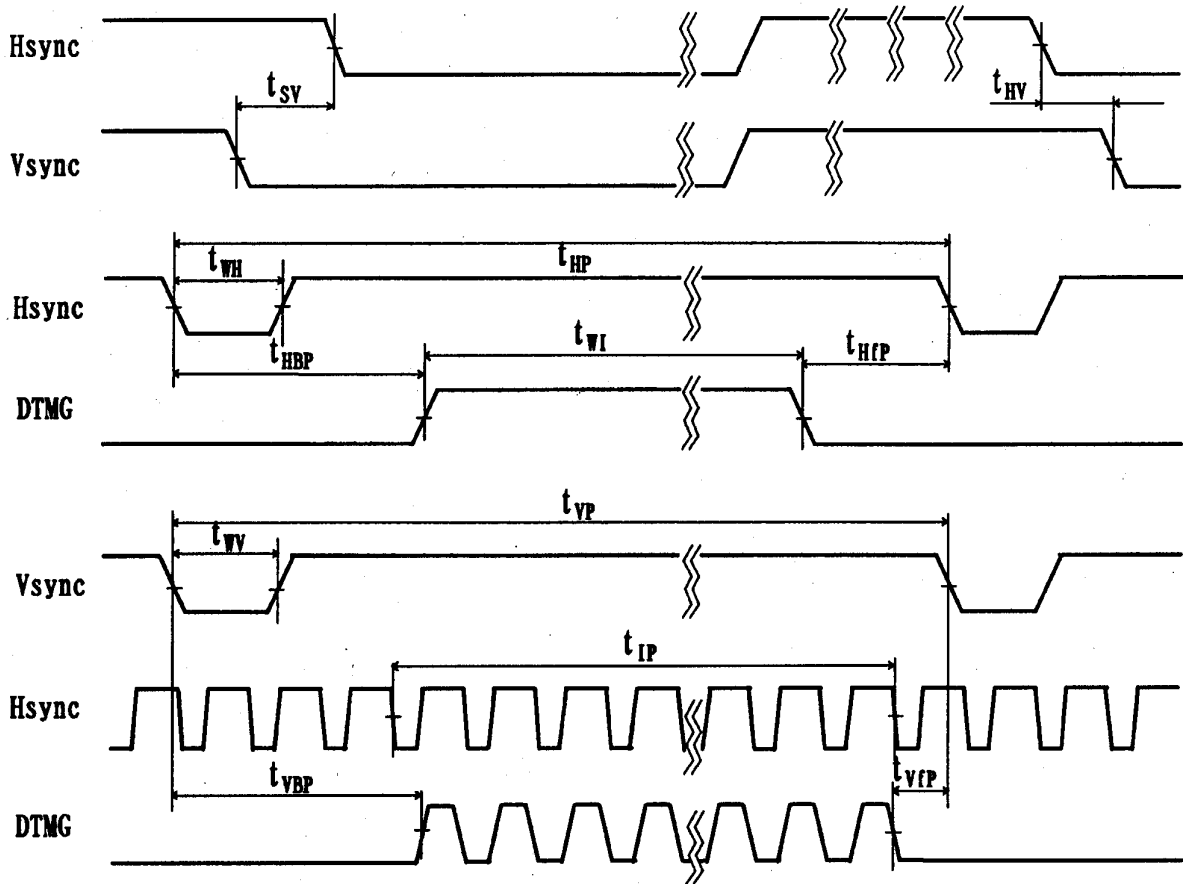

The timings except mentiodn on the above should conform to the pecifications of LVDS transmitter in your system.

Item		SYMBOL	MIN.	TYP.	MAX.	UNIT	NOTE
Hsync	Period	t _{HP}	820	844	1023	t _{CLK}	
	Width-Active	t _{WH}	(10)	—	(240)		
Vsync	Set up Time	t _{SV}	(-2)	—	—	t _{CLK}	for Hsync signal
	Hold time	t _{HV}	(0)	—	—		
	period	t _{VP}	1059	1068	2047	t _{HP}	
	Width-Active	t _{WV}	1	—	(120)	t _{HP}	
DTMG	Width-Active	t _{WI}	700	700	700	t _{CLK}	
	Period	t _{IP}	1050	1050	1050	t _{HP}	
	Horizontal Back Porch	t _{HBP}	(32)	—	(120)	t _{CLK}	
	Horizontal Front Porch	t _{HFP}	(0)	—	—		
	Vertical Back Porch	t _{VBP}	0	—	—	t _{HP}	1)
	Vertical Front Porch	t _{VFP}	1	—	—		

NOTE In addition to the above, t_{VBP} and t_{VFP} should be

1) $t_{VBP} + t_{VFP} \geq 3 \times t_{HP}$

(3) TIMING BETWEEN INTERFACE SIGNAL AND POWER SUPPLY

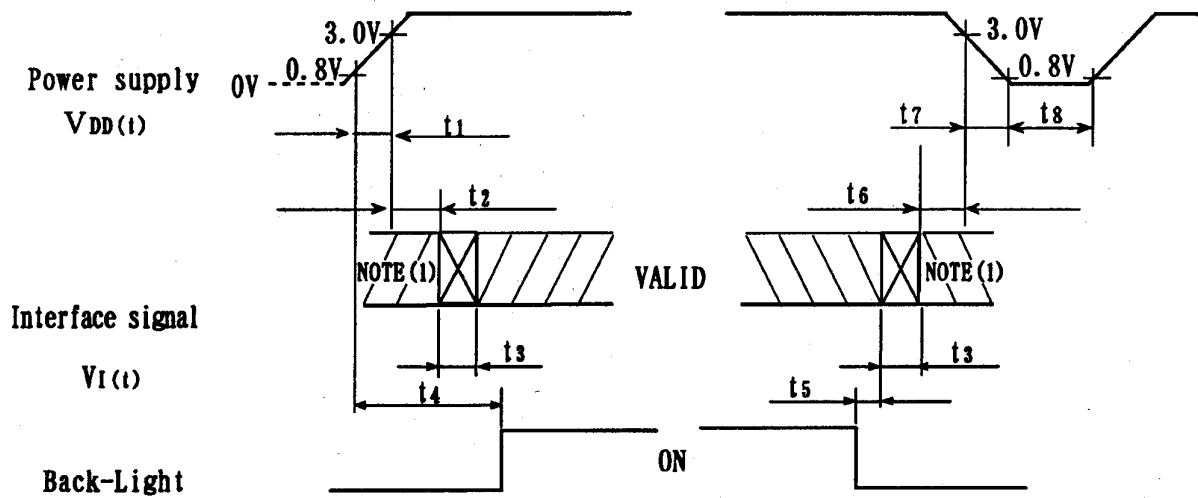

POWER ON

$$t_1 \leq 15\text{ms}$$

$$0 < t_2 \leq 45\text{ms}$$

$$0 \leq t_3 \leq 5\text{ms}$$

$$0.1\text{s} \leq t_4$$

POWER OFF

$$5\text{ms} \leq t_5$$

$$0 \leq t_6 \leq 45\text{ms}$$

$$0 \leq t_7 \leq 20\text{ms}$$

$$0.4\text{s} \leq t_8$$

NOTE(1) All input are in the High impedance state during t_2 .

(2) t_3 is needed for the signal transition between input High impedance state and valid state specified at 6(1) & (2).

7. DIMENSIONAL OUTLINE

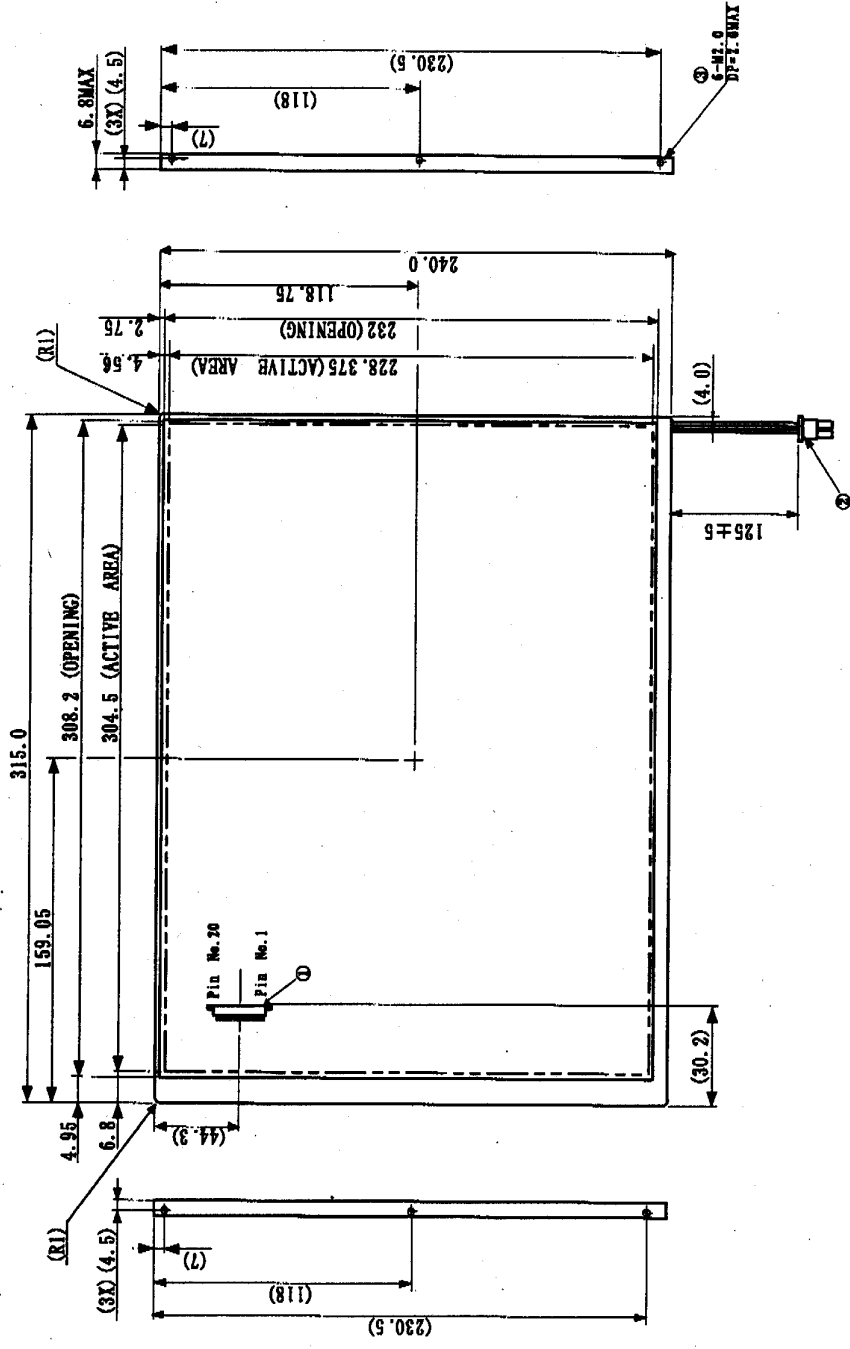

UNIT: mm

NOTES

- ① I/F CONNECTOR THIS PART NUMBER TO BE "FI-SEB20P-HP-A", OF JAE CO., LTD. OR COMPATIBLE.
- ② LAMP CONNECTOR THIS PART NUMBER TO BE "BESK-02YS-1" OF JST CO., LTD.
- ③ THESE HOLES TO BE USED FOR MOUNTING LCD MODULE IN THE SYSTEM ENCLOSURE. MAXIMUM TORQUE FOR THE SCREW IN MOUNTING PANEL : 0.196N·m (2.0kgf·cm) MAXIMUM PULL FOR THE SCREW IN MOUNTING PANEL : 24.5N (2.5kgf)
- ④ THE UNSPECIFIED TOLERANCE : ±0.5mm
- ⑤ DIMENSION MEASUREMENT SHOULD BE DONE WITH ADDING PRESSURE OF 9.8×10Pa.

8. DESIGNATION OF LOT MARK

8.1 LOT MARK

Lot Mark is consisted of 4 digits for production lot and 7 digits for production control.

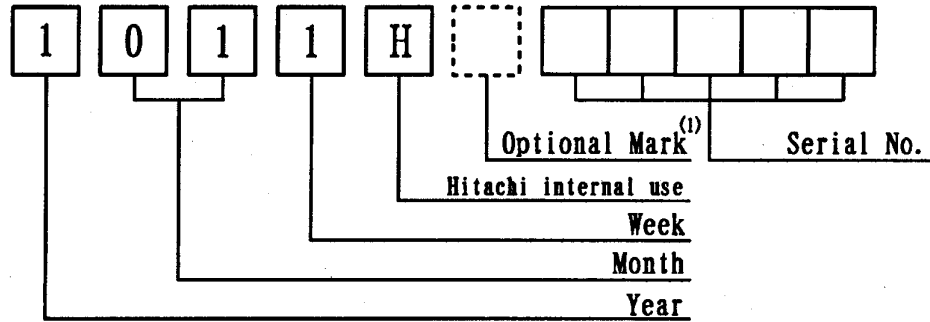

Year	Figure in Lot Mark
2001	1
2002	2
2003	3
2004	4

Week(day in calender)	Figure in Lot Mark
1~7	1
8~14	2
15~21	3
22~28	4
29~31	5

Note 1) Optional Mark for Hitachi.

Month	Figure in Lot Mark	Month	Figure in Lot Mark
1	01	7	07
2	02	8	08
3	03	9	09
4	04	10	10
5	05	11	11
6	06	12	12

8.2 Serial No.

Serial No. is consisted of 5 digits number (00001~99999).

8.3 LOCATION OF LOT MARK

Label is attached on the back side of module.

The items mentioned change without notice.

Lot No. &
Production Control No.

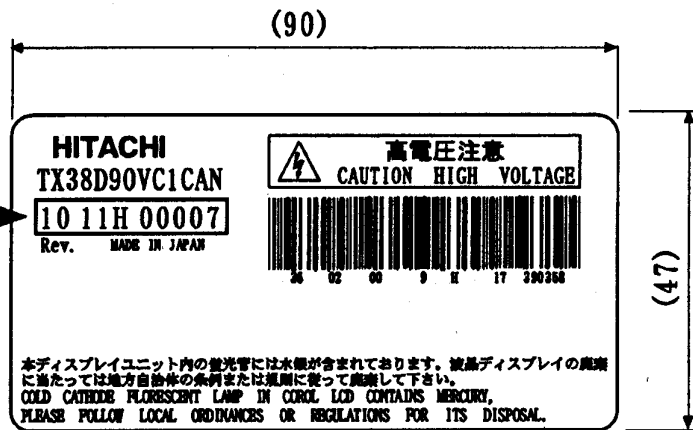

10. PRECAUTIONS

Please pay attention to the followings when you use this TFT/LCD module with Back-light unit.

10.1 MOUNTING PRECAUTION

- (1) You must mount Module using mounting holes arranged in 6 corners tightly.
- (2) You should consider the mounting structure so that uneven force (ex. twisted stress) is not applied to Module.
And the case which Module is mounted should have sufficient strength so that external force is not transmitted directly to Module.
- (3) To improve the strength of module against the mechanical shock the space between module and the case should be less than 1.0mm.

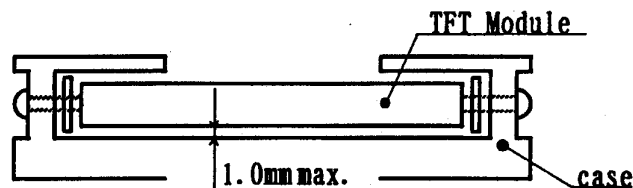

- (4) You should adopt radiation structure to satisfy the temperature specification.
- (5) Acetic acid type and chloline type materials for the cover case are not desirable because the former generate corrosive gas of attacking the polarizer at high temperature and the latter causes circuit break by electro-chemical reaction.
- (6) Do not touch, push or rub the exposed polarizers with glass, tweezers or anything harder than HB pencil lead. And please do not rub by dustclothes with chemical treatment.
Do not touch the surface of polarizer with bare hand or greasy close.
(Some cosmetics are detrimental to the polarizer.)
- (7) When the surface becomes dusty, please wipe gently with absorbent cotton or other soft materials chamois soaked petroleum benzin.
Normal-Hexane is recommended for cleaning the adhesives used to attach front /rear polarizers. Do not use acetone, toluen and alcohol because they cause chemical damage to the polarizer.
- (8) Wipe off saliva or water drops as soon as possible. Their long time contact with polarizer causes deformations and color fading.
- (9) Do not open the case because inside circuits have not sufficient strength.
- (10) Use fingerstalls of soft gloves in order to keep clean display quality, when you handle the device for incoming inspection and assembly.
- (11) Do not pull or do not fold the CFL cable.

Hitachi, Ltd.	Date	Jul. 24, 2001	Sh. No.	3284TTD 1553-1	Page	12-1/4
---------------	------	---------------	------------	----------------	------	--------

10.2 OPERATING PRECAUTION

- (1) Response time depends on the temperature. (In lower temperature, it becomes longer).
And also Transmittance and Color depend on the temperature.
- (2) Brightness depends on the temperature. (In lower temperature, it becomes lower).
And in lower temperature, response time (required time that brightness is stable after turn on) becomes longer.
- (3) Be careful for condensation at sudden temperature change.
Condensation make damage to polarizer or electrical contact part.
And after fading condensation, smear or spot will occur.
- (4) When fixed patterns are displayed at long times, afterimage is likely to occur.
- (5) The Module have high frequency circuit. If you need to shield the electromagnetic noise, please do in yours.
- (6) When Back-light unit is operating, it sounds.
If you need to shield the noise, please do in yours.
- (7) Please connect the Back-light connector to the inverter circuit directly.
The long cable between CFL and the inverter may cause the brightness drop of CFL and may cause the rise of starting lamp Voltage(Vs).
- (8) Do not connect or remove the module from main system with power applied.

10.3 ELECTROSTATIC DISCHARGE CONTROL

Since Module is composed with electronic circuit, it is not strong to electrostatic discharge. Make certain that treatment persons are connected to ground through list band etc.. And don't touch I/F pin directly.

10.4 PRECAUTION FOR STRONG LIGHT EXPOSURE

Strong light exposure causes degradation of polarizer and color filter.

Hitachi, Ltd.	Date	Jul. 24, 2001	Sh. No.	3284TTD 1553-1	Page	12-2/4
---------------	------	---------------	------------	----------------	------	--------

10.5 STORAGE

When storing Module as spares for long time, the following precautions are necessary.

- (1) Store them in a dark place ; do not expose them to sunlight or fluorescent light.
Keep the temperature between 5°C and 35°C at normal humidity.
- (2) The polarizer surface should not come in contact with any other object. It is recommended that they be stored in the container in which they were shipped.

10.6 HANDLING PRECAUTIONS FOR PROTECTIVE FILM

- (1) When the protective film is peeled off, static electricity is generated between the film and the polarizer.
This film should be peeled off slowly and carefully by people who are electrically grounded and with well ion-blown equipment or in such a condition, etc.
- (2) The protective film is attached to the polarizer with a small amount of glue. If some stress is applied to rub the protective film against the polarizer during the time you peel off the film, the glue is apt to remain more on the polarizer. So please carefully peel off the protective film without rubbing it against the polarizer.
- (3) When the Module with protective film attached is stored for long time, sometimes there remains a very small amount of glue, still on the polarizer after the protective film is peeled off.
Please refrain from storing the Module at the high temperature and high humidity for glue is apt to remain in these condition.
- (4) The Glue may be taken for the Modules failure, but you can remove the Glue easily.
When the glue remains on the polarizer surface or its vestige is recognized, please wipe them off with absorbent cotton waste or other soft material like chamois soaked with Normal-hexane.

Hitachi, Ltd.	Date	Jul. 24, 2001	Sh. No.	3284TTD 1553-1	Page	12-3/4
---------------	------	---------------	------------	----------------	------	--------

10.7 SAFETY

- (1) If Module is broken, be careful to handle not to injure. (TFT/LCD and Lamp are made of glass.)
Please wash hands sufficiently when you touch the liquid crystal coming out from broken LCDs.
- (2) As Back-light unit has high voltage circuit internal, do not open the case and do not insert foreign materials in the case.
- (3) The LCD Modules include Cold Cathode Fluorescent Lamp(CFL).
CFL contains a small amount of mercury. Please follow local ordinances or regulations for disposal.
- (4) The CFL inverter should be designed to include the function of output shutdown in case the output overcurrent happer due to any backlight trouble. The shutdown function should be assured to work in abnormal condition at the actual system.

Hitachi, Ltd.	Date	Jul. 24, 2001	Sh. No.	3284TTD 1553-1	Page	12-4/4
---------------	------	---------------	------------	----------------	------	--------