

TORISAN

ENGINEERING SPECIFICATIONS

TFT COLOR LCD MODULE

TM121SV-02L01

- 31cm (12.1 inch) diagonal
- SVGA resolution (800 × R · G · B × 600 dots)
- With CFL backlight unit
- Nonglare surface type

(TENTATIVE)

Ver. 9 May 13, 1999

Tottori SANYO Electric Co., Ltd.
LCD Division

3-201, Minami-yoshikata, Tottori, 680-8634 Japan
TEL: 81-857-21-1958, 2941
FAX: 81-857-21-2265



Department Manager S. IWASAKI



Engineering Manager A. MATSUSHITA

■ NOTICES

1. The contents stated in this document and the product may be subject to change without prior notice.

When you kindly study to use this product, please ask us or our distributor for the latest information.

2. This product is developed and produced for usage onto normal electronic products (office automation equipments, communication peripherals, electric appliance products, game machines, etc.) and is not suitable for applications which need extremely high reliability and extreme safety (aero- or space-use machines, control equipments for nuclear power, life keeping equipments, etc.).

3. This document shall not grant or guarantee any right to adapt intellectual property or any other patents of third party.

4. Please use this product correctly according to operating conditions and precautions for use stated in this document.

Please install safety proof in your designing to avoid human accident, fire accident and social damage which may be resulted from malfunction of this product.

5. This product is not designed to withstand against radiant rays.

6. It is strictly prohibited to copy or publish a part or whole of this document without our prior written approval.

MECHANICAL CHARACTERISTICS

Ta=25°C

ITEM	SPECIFICATION	UNIT
Module size	275.0 (W) × 199.0 (H) × 6.9 _{max} (t)	mm
Resolution	800 × R · G · B (W) × 600 (H)	pixel
Dot pitch	0.1025 (W) × 0.3075 (H)	mm
Pixel pitch	0.3075 (W) × 0.3075 (H)	mm
Active viewing area	246.0 (W) × 184.5 (H)	mm
Bezel opening area	250.0 (W) × 188.5 (H)	mm
Weight	440 TYP.	g

ELECTRICAL ABSOLUTE MAXIMUM RATINGS

ITEM	SYMBOL	MIN	MAX	UNIT	NOTE
Power supply voltage	V _{DD} -V _{SS}	0	4.3	V	
Logic input voltage	V _I	V _{SS}	V _{DD}	V	
CFL lamp current	I _L	-	6	mA	

ENVIRONMENTAL ABSOLUTE MAXIMUM RATINGS

Ta=25°C

ITEM	SYMBOL	CONDITIONS	MIN	MAX	UNIT	NOTE
Ambient temperature	T _{ST}	Storage	-20	60	°C	Note 1
	T _{OP}	Operation	0	50		
Humidity	-	Ta ≤ 40°C		85	%RH	No condensation Note 2
Vibration	-	Storage	-	1.5	G	Note 3
Shock	-	Storage	-	50	G	XYZ 11ms/direction

Note 1) Care should be taken so that the LCD module may not be subjected to the temperature beyond this specification.

Note 2) Ta > 40°C: Absolute humidity shall be less than that of 85% RH/40°C.

Note 3) 10-200Hz, 30min/cycle, X/Y/Z each one cycle and except for resonant frequency.

ELECTRICAL CHARACTERISTICS

V_{DD}=3.3V, f_v=60Hz, f_{CLK}=40MHz, Ta=25°C

ITEM	SYMBOL	CONDITIONS	MIN	TYP	MAX	UNIT	NOTE
Power supply voltage	V _{DD} -V _{SS}		3.0	3.3	3.6	V	
Input logic voltage	V _{IH}	High level	2.0	-	V _{DD}	V	
	V _{IL}	Low level	V _{SS}	-	0.8		
Power Supply current	I _{DD}	Note 1	-	200	300	mA	

Note 1) Typ. value : display pattern is 64 gray scale bar.

OPTICAL CHARACTERISTICS

Ta=25°C, V_{DD}=3.3V, f_v=60Hz

ITEM	SYMBOL	CONDITIONS	MIN	TYP	MAX	UNIT	NOTE	
Brightness	B	$\phi=0^\circ$	-	100	-	cd/m ²	Note 5, 7	
Contrast ratio	K	$\phi=0^\circ$	150	-	-	-	Note 2, 4, 7	
Viewing angle range	ϕ	K>10	$\theta = 0^\circ$	30	-	-	deg.	Note 1, 2, 4, 7
			$\theta = 90^\circ$	45	-	-		
			$\theta = 180^\circ$	10	-	-		
			$\theta = 270^\circ$	45	-	-		
Response time	Rise	t _r	$\phi=0^\circ$	-	30	-	ms.	Note 3, 4, 7
	Fall	t _f		-	20	-		
Color of CIE Coordinate	Red	x	$\phi=0^\circ$	-	0.58	-	-	Note 4, 7
		y		-	0.34	-		
	Green	x		-	0.32	-		
		y		-	0.54	-		
	Blue	x		-	0.16	-		
		y		-	0.15	-		
	White	x		-	0.33	-		
		y		-	0.36	-		

Note 1) Definition of ϕ and θ :

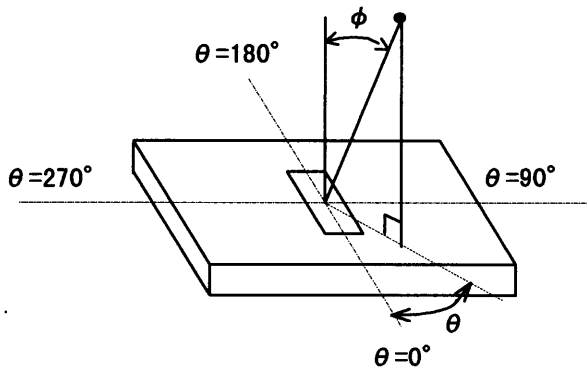

Note 2) Definition of Contrast ratio "K":

$$K = \frac{\text{Brightness at ON (White)}}{\text{Brightness at OFF (Black)}}$$

Note 3) Definition of Response time:

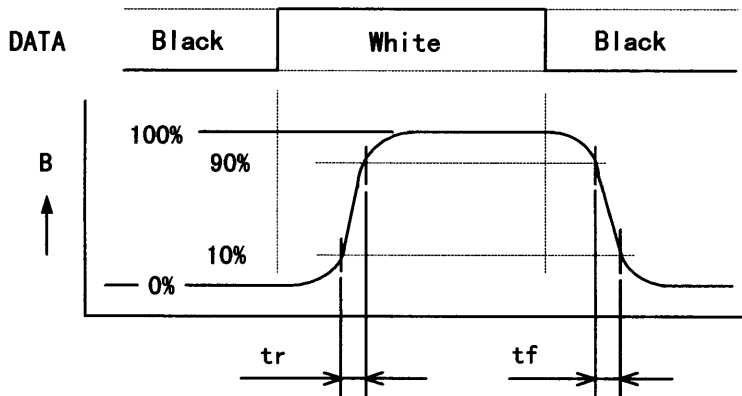

Note 4) Measurement point is the point 3 shown in Note 6 (center of active viewing area).

Note 5) The brightness shall be the average of 5 points shown in Note 6.

Note 6) Measurement points:

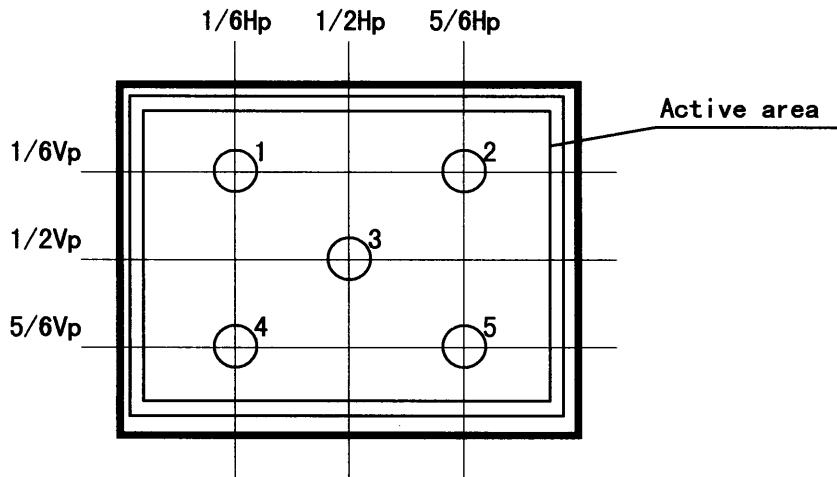

Vp : Total Number of Vertical pixel
Hp : Total Number of horizontal pixel

Note 7) Measurement conditions:

Measurement equipment : BM-7 (TOPCON Corp.), Field=2°

Ambient temperature : 25 ±2°C

LCD : All pixels are WHITE, V_{DD}=3.3V, f_v=60Hz.

Measure after 30 minutes of CFL warm up.

I_L= 3.0 mArms with the CFL inverter CFP-66-5.

■ BACKLIGHT CHARACTERISTICS

T_a=25°C

ITEM	SYM.	CONDITIONS	MIN	TYP	MAX	UNIT	NOTE
Lamp voltage	V _L		-	650	-	V _{rms}	at I _L =3.0mArms
Lamp current	I _L		2.5	-	5.5	mArms	(Recommend)
Operating frequency	f _L		-	50	-	kHz	
Start up voltage	V _s		-	-	1200	V _{rms}	at T _a = 0°C
Operating life	t _{OL}		20000	-	-	Hours	at I _L =6.0mArms

Note 1) Backlight driving conditions (operating frequency f_L especially) may interfere with horizontal frequency f_H, causing the beat or flicker on the display.

Therefore the operating frequency f_L shall be adjusted in relation to horizontal frequency f_H to avoid interference.

■ **BLOCK DIAGRAM**

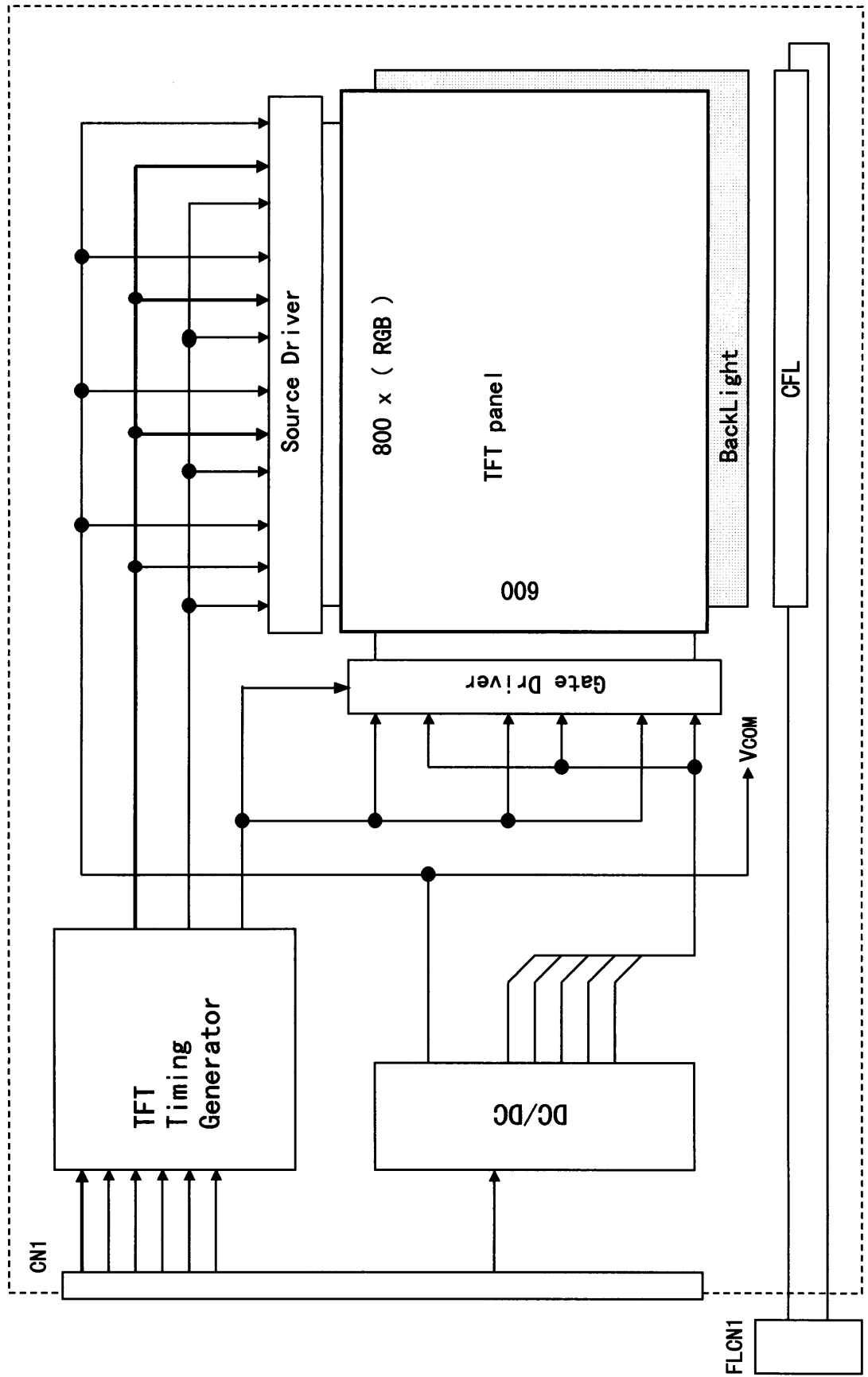

■ INTERFACE PIN CONNECTIONS

LCM : CN1

PIN NO.	SYMBOL	FUNCTION
1	Vss	Ground
2	DCLK	Data Clock
3	Vss	Ground
4	HSYNC	Horizontal Sync - This signal is invalid, input H or L.
5	VSYNC	Vertical Sync - This signal is invalid, input H or L.
6	Vss	Ground
7	Vss	Ground
8	Vss	Ground
9	R0	Red Data (LSB)
10	R1	Red Data
11	R2	Red Data
12	Vss	Ground
13	R3	Red Data
14	R4	Red Data
15	R5	Red Data (MSB)
16	Vss	Ground
17	Vss	Ground
18	Vss	Ground
19	G0	Green Data (LSB)
20	G1	Green Data
21	G2	Green Data
22	Vss	Ground
23	G3	Green Data
24	G4	Green Data
25	G5	Green Data (MSB)
26	Vss	Ground
27	Vss	Ground
28	Vss	Ground
29	B0	Blue Data (LSB)
30	B1	Blue Data
31	B2	Blue Data
32	Vss	Ground
33	B3	Blue Data
34	B4	Blue Data
35	B5	Blue Data (MSB)
36	Vss	Ground
37	DE	Data Enable(positive)
38	TEST	For display test, to be L.
39	VDD	Power Supply - 3.3V
40	VDD	Power Supply - 3.3V
41	NC	No Connection

Note) Valid synchronous signals are DCLK and DE. HSYNC and VSYNC are not used.

CN1 : DF9B-41P-1V(HIROSE)

Suitable mating connector : DF9B-41S-1V(HIROSE)

Back Light : FLCN1

PIN NO.	SYMBOL	FUNCTION
1	H.V	High voltage for CFL
2	N.C	No Connection
3	LGND	Low voltage for CFL

FLCN1 : BHR-03VS-1(JST)

Suitable mating connector : SM02(8.0)B-BHS-1(JST)

■ **INTERFACE TIMING PARAMETERS (DE_MODE)**

	PARAMETER	SYMBOL	MIN	TYP	MAX	UNIT	NOTE
DCLK	Frequency	f _{CLK}	38	40	41	MHz	t _{CLK} =1/f _{CLK}
	Width-Low	t _{WGL}	5	-	-	ns	
	Width-High	t _{WGH}	5	-	-	ns	
	Rise Time	t _{rCLK}	-	-	10	ns	
	Fall Time	t _{fCLK}	-	-	10	ns	
	Duty	D	(0.40)	0.50	(0.60)	-	D=t _{CLKL} /t _{CLK}
DE	Setup Time	t _{SI}	3	-	-	ns	For DCLK
	Hold Time	t _{HI}	6	-	-	ns	
	Rise/Fall Time	t _{ir} , t _{if}	-	-	10	ns	
	Horiz. Period	t _{HP}	950	1056	1100	t _{CLK}	
	Horiz. DE	t _{HDE}	800	800	t _{HP} -10	t _{CLK}	
	Vert. Period	t _{VP}	605	628	800	t _{HP}	60.317Hz typical
	Vert. DE	n _{VDE}	600	600	t _{VP} -5	n	Note 1
DATA	Setup Time	t _{SD}	3	-	-	ns	For DCLK
	Hold Time	t _{HD}	3	-	-	ns	
	Rise/Fall Time	t _{Dr} , t _{Df}	-	-	10	ns	

Note 1) The number of Vertical DE (n_{VDE}) should be even. If n_{VDE} is odd, the abnormal image may be displayed at the first horizontal line.

Note 2) Definition of Vertical Frequency f_v and Horizontal Frequency f_h:

$$f_v \text{ (Vertical Frequency)} = 1/t_{VP} \text{ (Vertical Period)}$$

$$f_h \text{ (Horizontal Frequency)} = 1/t_{HP} \text{ (Horizontal Period)}$$

■ **INTERFACE SIGNAL TIMING DIAGRAM (DE_MODE)**

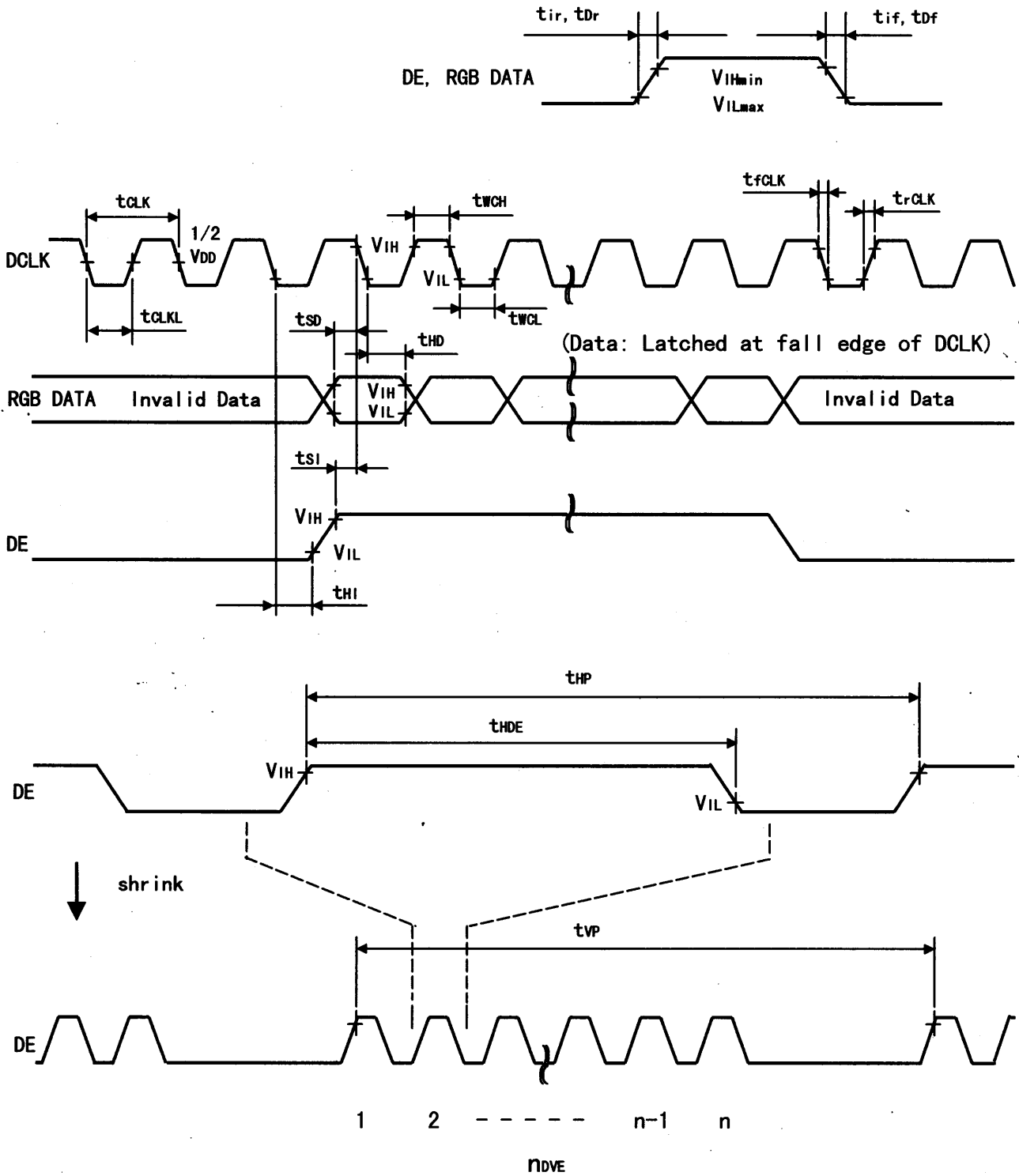

Note 1) Definition of Vertical Frequency f_v and Horizontal Frequency f_H :

$$f_v \text{ (Vertical Frequency)} = 1/t_{VP} \text{ (Vertical Period)}$$

$$f_H \text{ (Horizontal Frequency)} = 1/t_{HP} \text{ (Horizontal Period)}$$

■ **RELATIONSHIP BETWEEN INPUT DATA AND DISPLAY COLOR**

DISPLAY COLOR \ INPUT DATA		R DATA						G DATA						B DATA					
		MSB				LSB		MSB				LSB		MSB				LSB	
		R5	R4	R3	R2	R1	R0	G5	G4	G3	G2	G1	G0	B5	B4	B3	B2	B1	B0
BASIC COLOR	BLACK	L	L	L	L	L	L	L	L	L	L	L	L	L	L	L	L	L	L
	RED (63)	H	H	H	H	H	H	L	L	L	L	L	L	L	L	L	L	L	L
	GREEN (63)	L	L	L	L	L	L	H	H	H	H	H	H	L	L	L	L	L	L
	BLUE (63)	L	L	L	L	L	L	L	L	L	L	L	L	H	H	H	H	H	H
	CYAN	L	L	L	L	L	L	H	H	H	H	H	H	H	H	H	H	H	H
	MAGENTA	H	H	H	H	H	H	L	L	L	L	L	L	H	H	H	H	H	H
	YELLOW	H	H	H	H	H	H	H	H	H	H	H	H	L	L	L	L	L	L
	WHITE	H	H	H	H	H	H	H	H	H	H	H	H	H	H	H	H	H	H
RED	BLACK	L	L	L	L	L	L	L	L	L	L	L	L	L	L	L	L	L	L
	RED (1)	L	L	L	L	L	H	L	L	L	L	L	L	L	L	L	L	L	L
	RED (2)	L	L	L	L	H	L	L	L	L	L	L	L	L	L	L	L	L	L
	:																		
	:																		
	RED (61)	H	H	H	H	L	H	L	L	L	L	L	L	L	L	L	L	L	L
	RED (62)	H	H	H	H	H	L	L	L	L	L	L	L	L	L	L	L	L	L
RED (63)	H	H	H	H	H	H	L	L	L	L	L	L	L	L	L	L	L	L	
GREEN	BLACK	L	L	L	L	L	L	L	L	L	L	L	L	L	L	L	L	L	L
	GREEN (1)	L	L	L	L	L	L	L	L	L	L	L	H	L	L	L	L	L	L
	GREEN (2)	L	L	L	L	L	L	L	L	L	L	H	L	L	L	L	L	L	L
	:																		
	:																		
	GREEN (61)	L	L	L	L	L	L	H	H	H	H	L	H	L	L	L	L	L	L
	GREEN (62)	L	L	L	L	L	L	H	H	H	H	H	L	L	L	L	L	L	L
GREEN (63)	L	L	L	L	L	L	H	H	H	H	H	H	L	L	L	L	L	L	
BLUE	BLACK	L	L	L	L	L	L	L	L	L	L	L	L	L	L	L	L	L	L
	BLUE (1)	L	L	L	L	L	L	L	L	L	L	L	L	L	L	L	L	L	H
	BLUE (2)	L	L	L	L	L	L	L	L	L	L	L	L	L	L	L	L	H	L
	:																		
	:																		
	BLUE (61)	L	L	L	L	L	L	L	L	L	L	L	L	H	H	H	H	L	H
	BLUE (62)	L	L	L	L	L	L	L	L	L	L	L	L	H	H	H	H	H	L
BLUE (63)	L	L	L	L	L	L	L	L	L	L	L	L	H	H	H	H	H	H	

Note 1) Color (n) --- 'n' indicates gray scale step.

■ **RELATIONSHIP BETWEEN INPUT DATA AND DISPLAY POSITION**

1-1	1-2	1-3										1-799	1-800
2-1	2-2											2-800		
3-1														
.														
.														
.														
.														
599-1											599-800			
600-1	600-2										600-799	600-800	

Vp · Hp RGB

■ POWER ON/OFF SEQUENCE REQUIREMENT

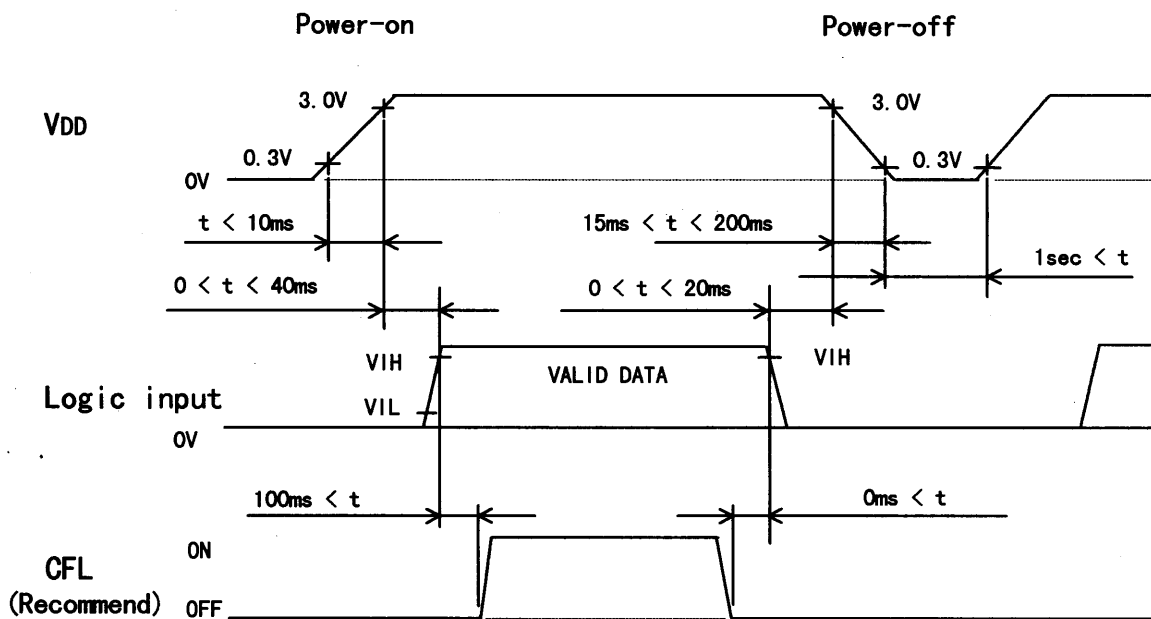

When the power is off, logic input must be kept at either low level or high impedance.

Power sequence for backlight is not specified especially, however it is recommended to consider some timing difference between logic input as shown above.

If backlight lights on before LCD starts function, or if backlight is kept on after LCD stopped function, screen may look white for a moment or abnormal image may be displayed.

This is caused by variation in output signal from internal timing generator at logic input on or off.

It does not cause damage to liquid crystal molecule and driving circuit.

■ PRECAUTIONS

1. This data sheet explains the outline of LCD module. Before designing your system with this LCD module, please ask for specification to understand our more precautions and recommendations.
2. Please avoid disassembling or modification of this module.
3. Since this LCD module consists of glass, dropping, pinching strongly or punching may break or result in damage. When glass breaks, please be careful not to be injured by glass piece.
4. When glass breaks and fluid flows out, do not suck in, drink or touch the fluid. If the fluid should stick to hand or clothes, wipe off with soap or alcohol immediately and then wash it with water. If the fluid should get in eyes, wash eyes immediately with washing lotion for more than 15 minutes and then consult the doctor.
5. Since high voltage is applied to CFL during lighting, please make design to avoid electric shock or take care in handling. Since poor connection of CFL connector may cause burning due to leakage of high voltage, please make sure of proper connection.
6. CFL contains mercury inside. Please follow regulations or rules established by local autonomy at its disposal.
7. Please do not rub, press or touch the display surface with hard material or jigs, because the polarizer at surface can be easily scratched. When the display surface gets a drop of water or contamination, wipe it off lightly with soft cloth.
8. Since this LCD module contains semiconductors, please pay attention against static-electricity in handling.
9. Please switch OFF power supply before connecting or disconnecting interface connector.
10. For storage, please store under room temperature, low humidity and dark circumstance in original packing condition.

TM121SV-02L01 Outer Dimensions

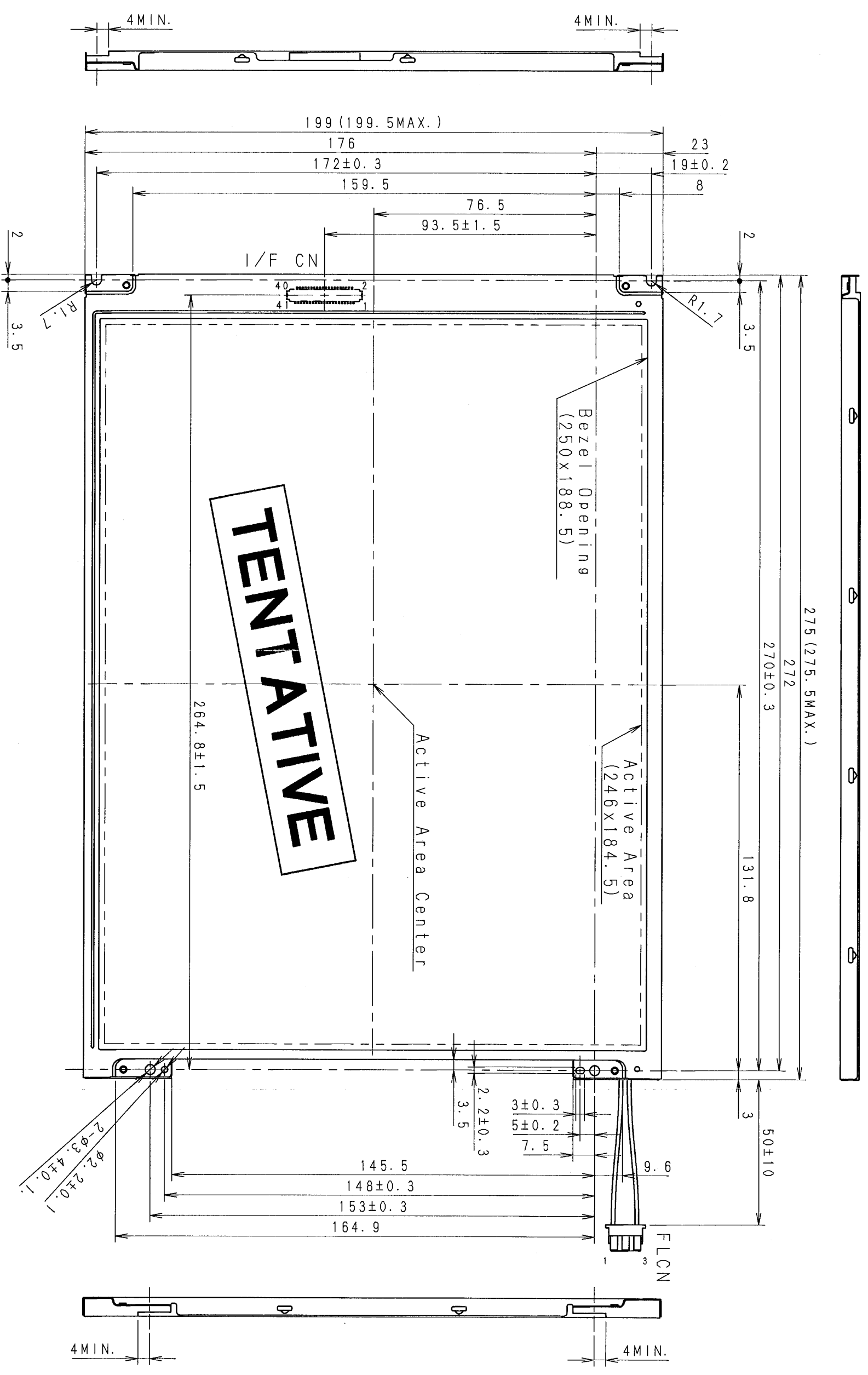

TENTATIVE

NOTE: ALL DIMENSIONAL TOLERANCE ±0.5
UNLESS OTHERWISE SPECIFIED

6.9 MAX.
4-5±0.3
4-2.5±0.3

FLCN
9.6
3±0.3
5±0.2
7.5
50±10
3
131.8
270±0.3
272
275 (275.5 MAX.)

2-φ3.4±0.1
2-φ2.2±0.1

I/F CN: DF9B-41P-1V (HIROSE)
FLCN : BHR-03VS-1 (JST)

Tottori SANYO Electric Co., Ltd. TM121SV-02L01 Ver. 9 Page 12/12

Unit: mm