

MODEL NO. : TM057KDH01ISSUED DATE: 2009-11-23VERSION : Ver 0.1**■Provisional Draft**

Customer : _____

Approved by	Notes

SHANGHAI TIANMA Confirmed :

Prepared by	Checked by	Approved by

This technical specification is subjected to change without notice

The information contained herein is the exclusive property of SHANGHAI TIANMA MICRO-ELECTRONICS Corporation, and shall not be distributed, reproduced, or disclosed in whole or in part without prior written permission of SHANGHAI TIANMA MICRO-ELECTRONICS Corporation.



Table of Contents

Coversheet.....	1
Table of Contents	2
Record of Revision.....	3
1 General Specifications	4
2 Input/Output Terminals	5
3 Absolute Maximum Ratings.....	7
4 Electrical Characteristics	8
5 Timing Chart.....	11
6 Optical Characteristics	14
7 Environmental / Reliability Test	17
8 Mechanical Drawing	18
9 Packing Drawing	19
10 Precautions for Use of LCD Modules	20



Record of Revision

Rev	Issued Date	Description	Editor
0.0	2009-10-21	Provisional Draft Release for reference	Wanjun_Li
0.1	2009-11-23	Modify the BLU Interface on Page6 and Page9, Update Mechanical Drawing on Page18	Wanjun_Li

The information contained herein is the exclusive property of SHANGHAI TIANMA MICRO-ELECTRONICS Corporation, and shall not be distributed, reproduced, or disclosed in whole or in part without prior written permission of SHANGHAI TIANMA MICRO-ELECTRONICS Corporation.



1 General Specifications

Feature		Spec
Display Spec.	Size	5.7 inch
	Resolution	320(RGB) x 240
	Interface	RGB 18-bit
	Color Depth	6-bit
	Display colors	262K
	Technology Type	a-Si TFT
	Pixel Pitch (mm)	0.360 x 0.360
	Pixel Configuration	R.G.B. Vertical Stripe
	Display Mode	TM with Normally White
	Surface Treatment(Up Polarizer)	Anti-Glare, Hardness 3H
	Viewing Direction	6 o'clock
	Gray Scale Inversion Direction	12 o'clock
Mechanical Characteristics	LCM (W x H x D) (mm)	144.00x104.60x12.30
	Active Area(mm)	115.20 x 86.40
	With /Without TSP	Without TSP
	Weight (g)	TBD
	LED Numbers	15 LEDs

Note 1: Viewing direction for best image quality is different from TFT definition. There is a 180 degree shift.

Note 2: Requirements on Environmental Protection: RoHS

Note 3: LCM weight tolerance: +/- 5%



2 Input/Output Terminals

2.1 CN1 pin assignment (Signal interface)

Connector type: 089H33-000100-G2-R (STARCONN)

Pin	Symbol	I/O	Description	Remark
1	GND	P	Ground	
2	DOTCLK	I	Dot clock. Latch data at falling edge of DOTCLK.	
3	Hsync	I	Horizontal sync signal in SYNC mode.	
4	Vsync	I	Vertical sync signal in SYNC mode.	
5	GND	P	Ground	
6	R0	I	Red data (LSB)	
7	R1	I	Red data	
8	R2	I	Red data	
9	R3	I	Red data	
10	R4	I	Red data	
11	R5	I	Red data (MSB)	
12	GND	P	Ground	
13	G0	I	Green data(LSB)	
14	G1	I	Green data	
15	G2	I	Green data	
16	G3	I	Green data	
17	G4	I	Green data	
18	G5	I	Green data(MSB)	
19	GND	P	Ground	
20	B0	I	Blue data(LSB)	
21	B1	I	Blue data	
22	B2	I	Blue data	
23	B3	I	Blue data	
24	B4	I	Blue data	
25	B5	I	Blue data(MSB)	
26	GND	P	Ground	
27	ENABLE	I	Data enable signal in DE mode. This pin must be floating when SYNC mode.	
28	VCC	P	Power supply	
29	VCC	P	Power supply	



30	R/L	I	Set horizontal scan direction: Low/NC: left to right; High: right to left	
31	U/D	I	Set vertical scan direction: High/NC: up to down; Low: down to up	
32	NC	-	No connection	
33	GND	P	Ground	

P: Power/GND; I: input pin;

Note1: CN1 Matching FPC type: 33 pin, pitch: 0.5mm, height: 0.3mm.

2.1 Backlight interface

Connector type: SHLP-06V-S-B (JST)

No	Symbol	I/O	Description	Remark
1	AN1	P	LED driving anode 1 (high voltage)	Red
2	AN2	P	LED driving anode 2 (high voltage)	Red
3	AN3	P	LED driving anode 3 (high voltage)	Red
4	CA1	P	LED driving cathode 1 (low voltage)	White
5	CA2	P	LED driving cathode 2 (low voltage)	Blue
6	CA3	P	LED driving cathode 3 (low voltage)	Black

Note1: CN2 Matching Connector type: SM06B-SHLS-TF (JST)



3 Absolute Maximum Ratings

GND=0V, Ta = 25°C

Item	Symbol	MIN	MAX	Unit	Remark
Power Voltage	VCC	-0.5	5.0	V	
Input voltage	V _{IN}	-0.5	5.0	V	Note1
Operating Temperature	Top	-20	70	°C	
Storage Temperature	Tst	-30	85	°C	

Note1: Signals include R0~R5, G0~G5, B0~B5, Dotclk, Hsync, Vsync, Enable, R/L, U/D.



4 Electrical Characteristics

4.1 LCD module

GND=0V, Ta=25°C

Item	Symbol	MIN	TYP	MAX	Unit	Remark	
Supply Voltage	VCC	3.00	3.30	3.60	V		
Permissive input ripple voltage	V _{RF}	-	-	100	mVp-p	VCC=3.3V	
Input Signal Voltage	Low Level	V _{IL}	0	-	0.3*VCC	V	
	High Level	V _{IH}	0.7*VCC	-	VCC	V	
Common Electrode Driving Signal	VCOM	-	TBD.	-	V	Note1	
Current of VCC Power supply	I _{VCC}	-	TBD.	TBD.	mA	Note2	

Note1: For different LCM, the value may have a bit of difference.

Note2: To test the current dissipation, use "all Black Pattern".



4.2 Recommended Driving Condition for Backlight

 $T_a=25^{\circ}\text{C}$

Item	Symbol	MIN	TYP	MAX	Unit	Remark
Channel 1 Forward Current	$I_{\text{channel 1}}$	-	25.0	-	mA	
Channel 2 Forward Current	$I_{\text{channel 2}}$	-	25.0	-	mA	
Channel 3 Forward Current	$I_{\text{channel 3}}$	-	25.0	-	mA	
Forward Voltage	V_{BL}	14.85	-	18.15	V	Note 2
Backlight Power Consumption	W_{BL}	-	1238	-	mW	Note 1

Note 1: The LED driving condition is defined for total backlight consumption.

Note 2: Forward Voltage adjusting must depend on Forward Current setting.

Note 3: One LED: $I_F=25\text{ mA}$, $V_F=3.3\text{V}$.

Note 4: The LED LifetimeTyp.50, 000 hours.

LED Connection of Backlight

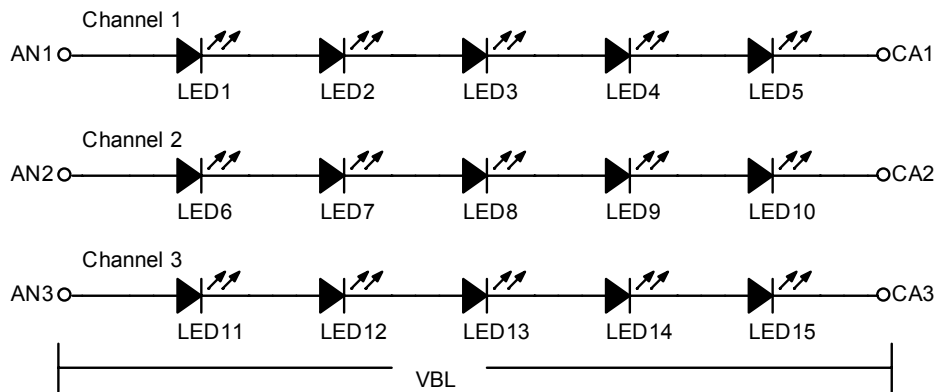



4.3 Block Diagram

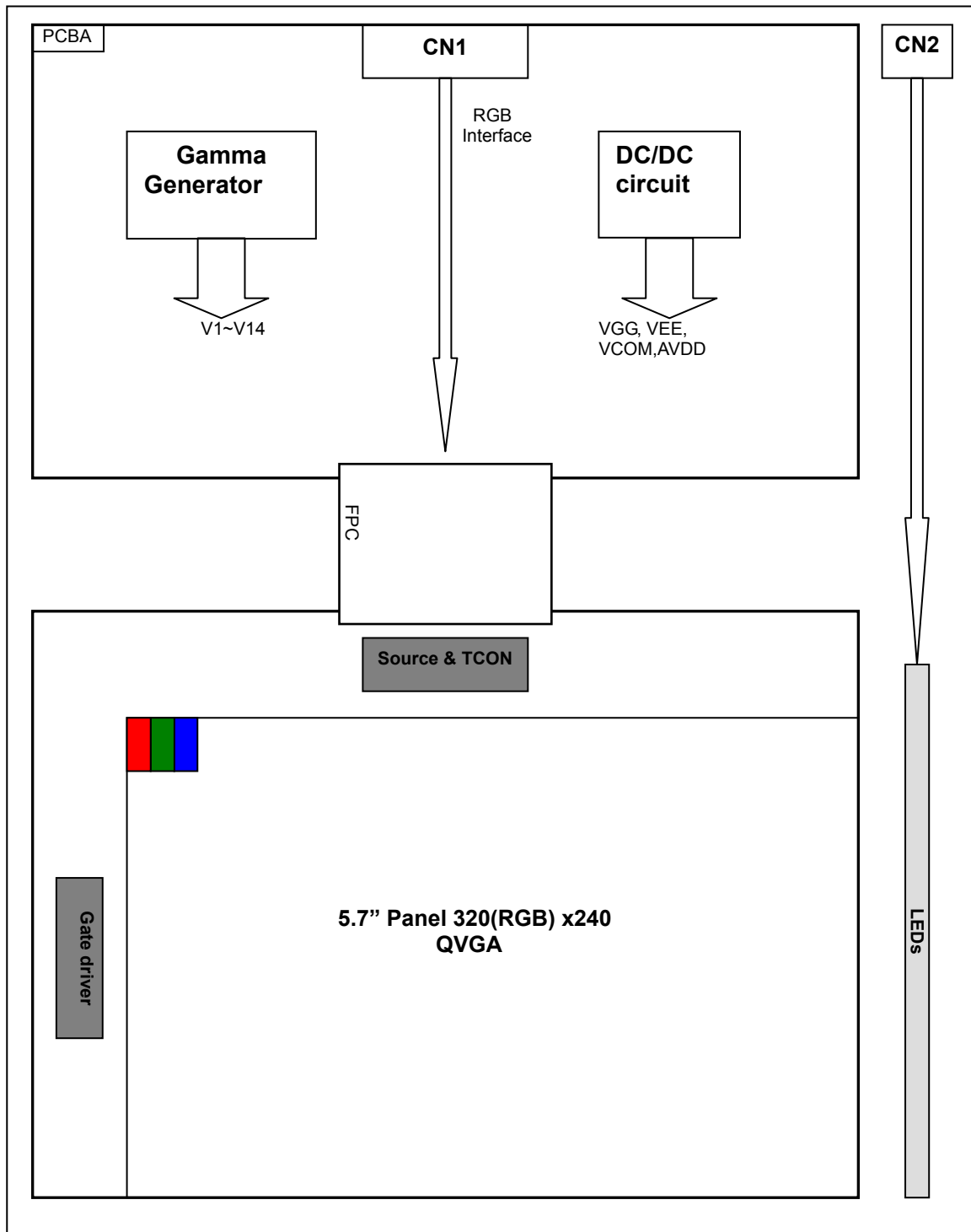



5 Timing Chart

5.1 AC Electrical Characteristics

5.1.1 SYNC mode:

Parameter	Description	Symbol	Min.	Typ.	Max.	Unit
Dotclk	Dotclk frequency	Fclk	6.2	6.4	12.1	MHz
	Dotclk cycle	Tclk	82.64	156.25	161.29	ns
Hsync	Horizontal display area	Thd	320	320	320	Tclk
	1 horizontal line	Th	406	408	560	Tclk
	Hsync pulse width	Thpw	1	-	-	Tclk
	Horizontal blanking	Thb	70	70	70	Tclk
	Horizontal front porch	Thfp	16	18	170	Tclk
Vsync	Frame rate	-	-	60	-	Hz
	Vertical display area	Tvd	240	240	240	Th
	Vsync period time	Tv	254	263	360	Th
	Vsync pulse width	Tvpw	1	-	-	Th
	Vsync blanking	Tvb	13	13	13	Th
	Vsync front porch	Tvfp	1	10	107	Th

5.1.2 DE mode:

Description		Symbol	Min.	Typ.	Max.	Unit
Dotclk frequency		Fclk	6.2	6.4	12.1	MHz
Horizontal section	Horizontal total	Th	406	408	560	Tclk
	H Total blank	Thb+Thfp	86	88	240	Tclk
	Valid Data Width	Thd	320	320	320	Tclk
Vertical section	Frame rate	-	-	60	-	Hz
	Vertical total	Tv	254	263	360	Th
	V total blank	Tvb+Tvfp	14	23	120	Th
	Valid Data Width	Tvd	240	240	240	Th

Note: The LCM could auto-detect which mode is working.



5.2 Timing Diagram

5.2.1 Vertical Input Timing

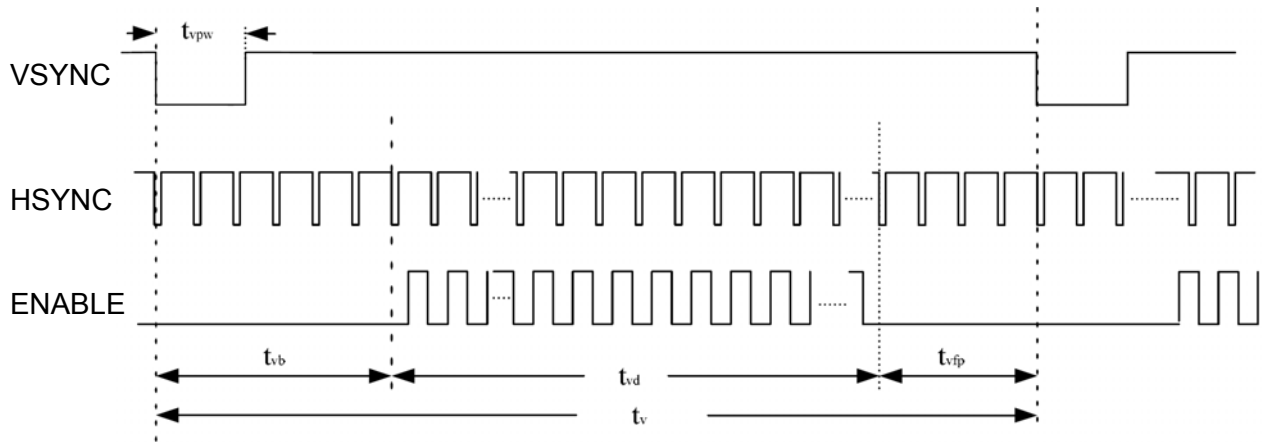

5.2.2 Horizontal Input Timing

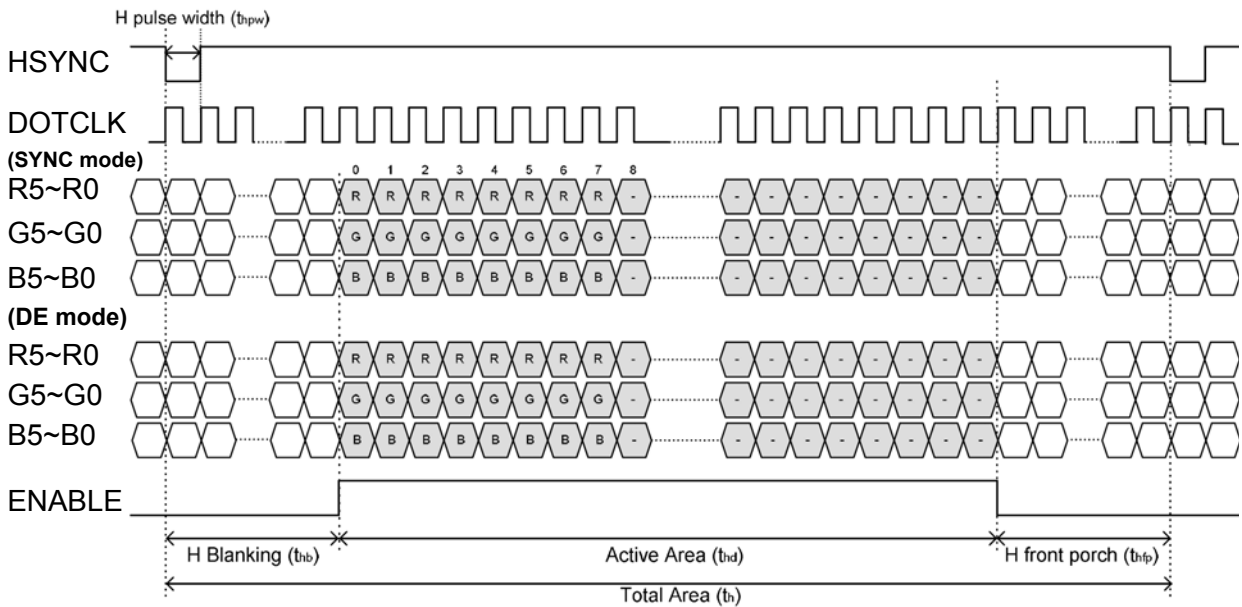

5.3 AC input characteristics

(VCC=3.3V, GND=0V, Ta=25°C)

Parameter	Symbol	Min	Typ	Max	Unit	Conditions
DOTCLK pulse duty	Tcwh	40%	50%	60%	Tclk	
VSYNC setup time	Tvst	8	-	-	ns	
VSYNC hold time	Tvhd	8	-	-	ns	
HSYNC setup time	Thst	8	-	-	ns	
HSYNC hold time	Thhd	8	-	-	ns	
Data setup time	Tdsu	8	-	-	ns	Rn, Gn, Bn to Dotclk
Data hold time	Tdhd	8	-	-	ns	Rn, Gn, Bn to Dotclk
Enable setup time	Tesu	8			ns	

The information contained herein is the exclusive property of SHANGHAI TIANMA MICRO-ELECTRONICS Corporation, and shall not be distributed, reproduced, or disclosed in whole or in part without prior written permission of SHANGHAI TIANMA MICRO-ELECTRONICS Corporation.

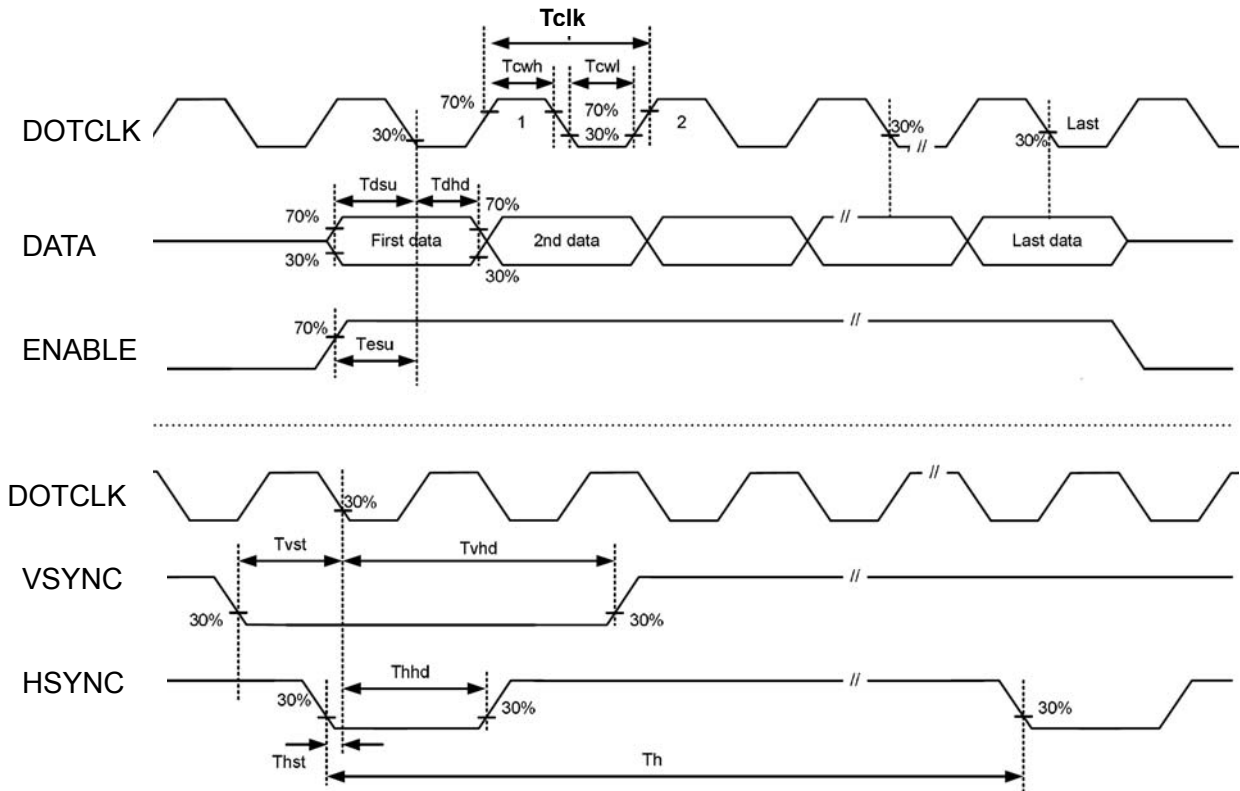

5.4 Power On\Off Sequence

Item	Symbol	MIN	TYP	MAX	Unit	Remark
VCC 3.0V to signal starting	Tp1	5	-	50	ms	
Signal starting to backlight on	Tp2	TBD.	-	-	ms	
Signal off to VCC 3.0V	Tp3	0	-	50	ms	
Backlight off to signal off	Tp4	TBD.	-	-	ms	

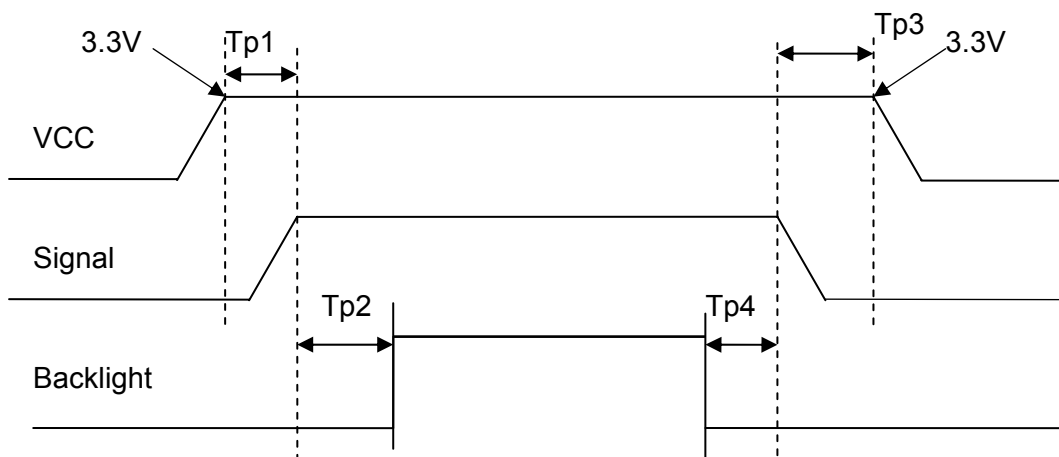

The information contained herein is the exclusive property of SHANGHAI TIANMA MICRO-ELECTRONICS Corporation, and shall not be distributed, reproduced, or disclosed in whole or in part without prior written permission of SHANGHAI TIANMA MICRO-ELECTRONICS Corporation.



6 Optical Characteristics

Ta=25°C

Item	Symbol	Condition	Min	Typ	Max	Unit	Remark
View Angles	θ_T	CR \geq 10	50	70	-	Degree	Note2,3
	θ_B		40	50	-		
	θ_L		50	70	-		
	θ_R		50	70	-		
Contrast Ratio	CR	$\theta=0^\circ$	400	500	-		Note 3
Response Time	T _{ON}	25°C	-	25	40	ms	Note 4
	T _{OFF}						
Chromaticity	White	Backlight is on	x	TBD	TBD	TBD	Note 1,5
			y	TBD	TBD	TBD	
	Red		x	TBD	TBD	TBD	Note 1,5
			y	TBD	TBD	TBD	
	Green		x	TBD	TBD	TBD	Note 1,5
			y	TBD	TBD	TBD	
	Blue		x	TBD	TBD	TBD	Note 1,5
			y	TBD	TBD	TBD	
Uniformity	U		75	80	-	%	Note 6
NTSC			-	50	-	%	Note 5
Luminance	L		300	400	-	cd/m ²	Note 7

Test Conditions:

1. The ambient temperature is 25°C.
2. The test systems refer to Note 1 and Note 2.



Note 1: Definition of optical measurement system.

The optical characteristics should be measured in dark room. After 5 Minutes operation, the optical properties are measured at the center point of the LCD screen. All input terminals LCD panel must be ground when measuring the center area of the panel.

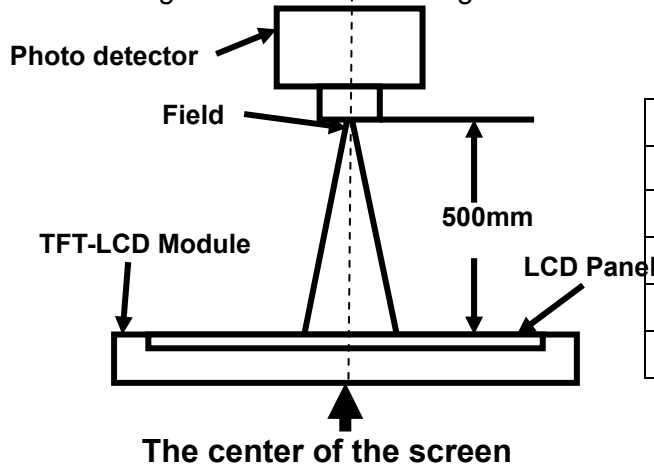

Item	Photo detector	Field
Contrast Ratio	SR-3A	1°
Luminance		
Chromaticity		
Lum Uniformity		
Response Time	BM-7A	2°

Note 2: Definition of viewing angle range and measurement system.

viewing angle is measured at the center point of the LCD by CONOSCOPE(ergo-80).

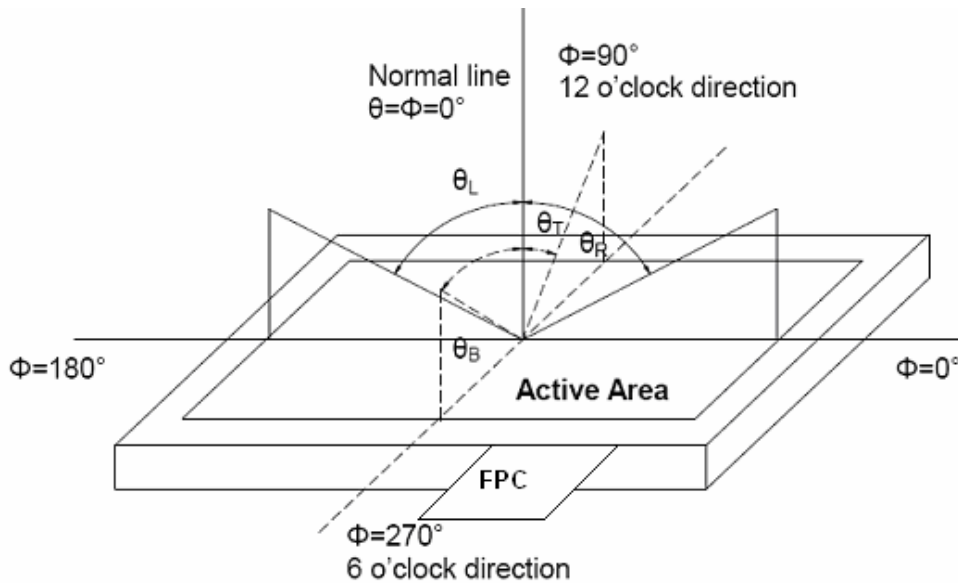

Note 3: Definition of contrast ratio

$$\text{Contrast ratio (CR)} = \frac{\text{Luminance measured when LCD is on the "White" state}}{\text{Luminance measured when LCD is on the "Black" state}}$$

“White state “: The state is that the LCD should drive by Vwhite.

“Black state”: The state is that the LCD should drive by Vblack.

Vwhite: To be determined Vblack: To be determined.



Note 4: Definition of Response time

The response time is defined as the LCD optical switching time interval between “White” state and “Black” state. Rise time (T_{ON}) is the time between photo detector output intensity changed from 90% to 10%. And fall time (T_{OFF}) is the time between photo detector output intensity changed from 10% to 90%.

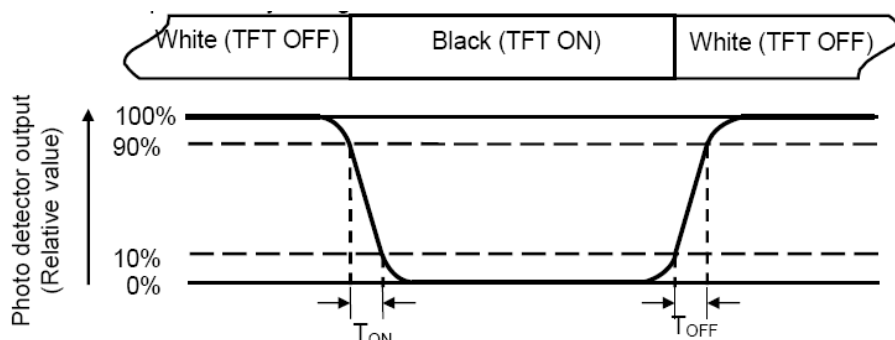

Note 5: Definition of color chromaticity (CIE1931)

Color coordinates measured at center point of LCD.

Note 6: Definition of Luminance Uniformity

Active area is divided into 9 measuring areas (Refer Fig. 2). Every measuring point is placed at the center of each measuring area.

Luminance Uniformity (U) = L_{min}/ L_{max}

L-----Active area length W----- Active area width

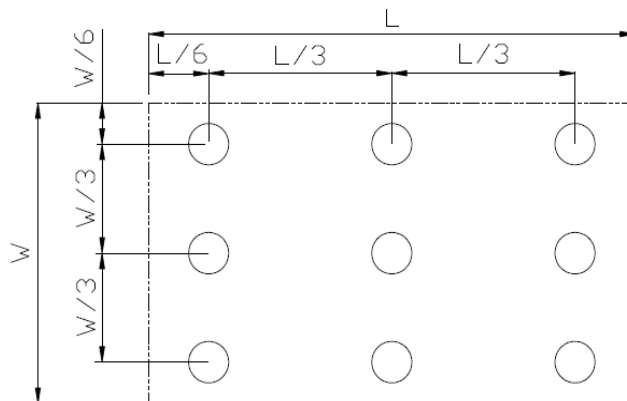

L_{max}: The measured Maximum luminance of all measurement position.

L_{min}: The measured Minimum luminance of all measurement position.

Note 7: Definition of Luminance:

Measure the luminance of white state at center point.



7 Environmental / Reliability Test

No	Test Item	Condition	Remark
1	High Temperature Operation	Ts=+85℃, 240hrs	Note1 IEC60068-2-2,GB2423.2—89
2	Low Temperature Operation	Ta=-30℃, 240hrs	IEC60068-2-1 GB2423.1—89
3	High Temperature Storage (non-operation)	Ta=+85℃, 240hrs	IEC60068-2-2, GB2423.2—89
4	Low Temperature Storage (non-operation)	Ta=-30℃, 240hrs	IEC60068-2-1 GB2423.1—89
5	High Temperature & High Humidity Operation	Ta = +60℃,90% RH max,240 hours	Note2 IEC60068-2-3, GB/T2423.3—2006
6	Thermal Shock (non-operation)	-20℃ 30 min~+60℃ 30 min, Change time:5min, 100 Cycle	Start with cold temperature, end with high temperature IEC60068-2-14,GB2423.22—87
7	Electro Static Discharge (operation)	Contact : ± 8KV/ operation, Class B; Air : ± 15KV / operation, Class B (RL=150_, CL=330pF)	IEC61000-4-2 GB/T17626.2—1998
8	Vibration (non-operation)	Sine wave, 1.5G, 10~200~10Hz, 30mins/axis, 3 direction (X, Y, Z)	IEC60068-2-6 GB/T2423.10—1995
9	Shock (non-operation)	50G,20ms,Half-sine wave, (±X, ±Y, ±Z) 3times for each direction	IEC60068-2-27 GB/T2423.5—1995
10	Package Drop Test	Height:80 cm,1 corner, 3 edges, 6 surfaces	IEC60068-2-32 GB/2423.8—1995
11	Package Vibration Test	Random Vibration: 0.015G*G/Hz for 5-200Hz, -6dB/Octave from 200-500Hz 2 hours for each direction of X,Y,Z (6 hours for total)	IEC60068-2-34

Note1: Ts is the temperature of panel's surface.

Note2: Ta is the ambient temperature of samples.



8 Mechanical Drawing

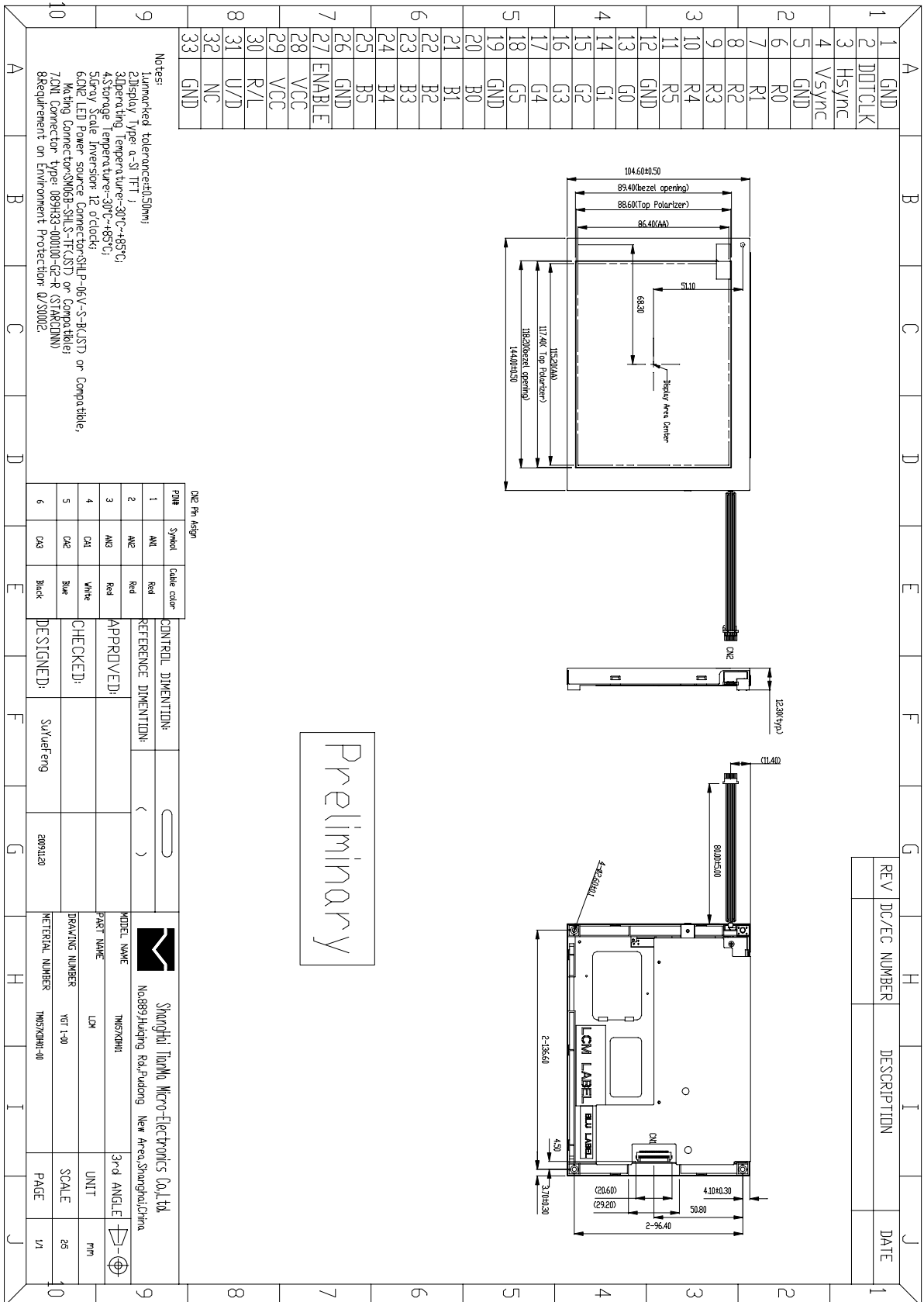

Preliminary

REV	DEC NUMBER	DESCRIPTION	DATE



9 Packing Drawing (TBD)

No	Item	Model (Material)	Dimensions(mm)	Unit Weight (Kg)	Quantity	Remark
1						
2						
3.						
4						
5						
6						
7						
8						



10 Precautions for Use of LCD Modules

- a) Handling Precautions
 - i. The display panel is made of glass. Do not subject it to a mechanical shock by dropping it from a high place, etc.
 - ii. If the display panel is damaged and the liquid crystal substance inside it leaks out, be sure not to get any in your mouth, if the substance comes into contact with your skin or clothes, promptly wash it off using soap and water.
 - iii. Do not apply excessive force to the display surface or the adjoining areas since this may cause the color tone to vary.
 - iv. The polarizer covering the display surface of the LCD module is soft and easily scratched. Handle this polarizer carefully.
 - v. If the display surface is contaminated, breathe on the surface and gently wipe it with a soft dry cloth. If still not completely clear, moisten cloth with one of the following solvents:
 - Isopropyl alcohol
 - Ethyl alcohol
 - vi. Solvents other than those mentioned above may damage the polarizer. Especially, do not use the following:
 - Water
 - Ketone
 - Aromatic solvents
 - vii. Do not attempt to disassemble the LCD Module.
 - viii. If the logic circuit power is off, do not apply the input signals.
 - ix. To prevent destruction of the elements by static electricity, be careful to maintain an optimum work environment.
 - b) Be sure to ground the body when handling the LCD Modules.
 - c) Tools required for assembly, such as soldering irons, must be properly ground.
 - d) To reduce the amount of static electricity generated, do not conduct assembly and other work under dry conditions.
 - e) The LCD Module is coated with a film to protect the display surface. Be care when peeling off this protective film since static electricity may be generated.
 - f) Storage precautions
 - i. When storing the LCD modules, avoid exposure to direct sunlight or to the light of fluorescent lamps.
 - ii. The LCD modules should be stored under the storage temperature range. If the LCD modules will be stored for a long time, the recommend condition is:
 - g) Temperature : 0°C ~ 40°C Relatively humidity: ≤80%
 - i. The LCD modules should be stored in the room without acid, alkali and harmful gas.
 - ii. Transportation Precautions
 - h) The LCD modules should be no falling and violent shocking during transportation, and also should avoid excessive press, water, damp and sunshine.