



## ENGINEERING SPECIFICATIONS

TFT COLOR LCD MODULE

### **TM038QV-67A02A**

- 9.7cm (3.8 inch) diagonal
- Quarter VGA resolution (320 x 240 pixels)
- 6 bits x RGB interface
- With CFL front light unit
- Glare surface type
- With touch panel

(TENTATIVE)

Ver.1

Jun. 28, 2001

Tottori SANYO Electric Co., Ltd.  
Electronic Device Business Headquarters  
LCD Division

3-201, Minami-yoshikata, Tottori, 680-8634 Japan

TEL: 81-857-21-2941, 1958

FAX: 81-857-21-2162

---

General Manager

S. IWASAKI

---

Engineering Manager

N. OMOTE



## MECHANICAL CHARACTERISTICS

Ta=25 degC

ITEM	SPECIFICATION	UNIT
Module size	96.8(W) x 73.0(H) x 5.1 Typ.(t)	mm
Resolution	320 x R.G.B(W) x 240(H)	pixel
Sub pixel pitch	0.08(W) x 0.24(H)	mm
Pixel pitch	0.24(W) x 0.24(H)	mm
Active viewing area	76.8(W) x 57.6(H)	mm
Bezel opening area	80.0(W) x 62.2(H)	mm
Weight	(65)	g
Touch panel	Glare type (Surface Hardness : 3H)	

## ELECTRICAL ABSOLUTE MAXIMUM RATINGS

Ta=25 degC

ITEM		SYMBOL	MIN	MAX	UNIT	NOTE
Power supply voltage	Digital	VDD	0	4.3	V	
	Analog	VCC	0	6.0	V	
	Gate	VGH	-0.5	28	V	
		VGL	-23	0.5	V	
	VGH-VGL	-0.5	33	V		
Driving signal		VCOM	-1.5	5	V	
Input voltage	Digital	VIN	VSS-0.3	VDD+0.3	V	
	$\gamma$ voltage	V0-V10	0	VCC+0.3	V	Note 1
	Touch panel		0	7.0	V	
CFL lamp current		IL	-	6.0	mA	

[Note 1] V0,V1,V2,V3,V4,V5,V6,V7,V8,V9,V10

## ENVIRONMENTAL ABSOLUTE MAXIMUM RATINGS

Ta=25 degC

ITEM	SYMBOL	CONDITIONS	MIN	MAX	UNIT	NOTE
Ambient temperature	TST	Storage	-30	60	degC	Note 1
	TOP	Operation	0	50		
Humidity	-	Ta=40 degC max.	-	90	%RH	No condensation Note 2
Vibration	-	Storage	-	3.5	G	Note 3
Shock	-	Storage	-	240	G	Note 4

[Note 1] Care should be taken so that the LCD module may not be subjected to the temperature beyond this specification.

[Note 2] Ta>40 degC : Absolute humidity shall be less than that of 90%RH/40 degC.

[Note 3] Random Vibration : 0.025G<sup>2</sup>/Hz, 10 to 500Hz, nominal 3.5 GRMS. In each of three mutually perpendicular axes. The test duration shall be one hour/axis for a total test duration of three hours.

[Note 4] Half Sine Wave Shock : 240G peak, half sine pulse, 2 ms pulse duration.

There shall be one shock input in each direction of three mutually perpendicular axes for a total of six shock input.

## ELECTRICAL CHARACTERISTICS for LCD

VDD=3.3V ,fV=60Hz ,fCLK=6MHz ,Ta=25 degC

ITEM		SYMBOL	CONDITIONS	MIN	TYP	MAX	UNIT	NOTE	
Power supply voltage	Digital	VDD		3.0	3.3	3.6	V	Note 1	
	Analog	VCC		4.75	5	5.25	V		
	Gate	VGH		(14.3)	(15)	(15.7)	V		
VGL			(-11)	(-10)	(-9)	V			
Driving signal		VCOM AC		±2.3	±2.5	±2.7	V	Note 4	
		VCOM DC		+1.6	+1.7	+1.8	V		
Input voltage	High level	VIH		2.0	-	VDD	V	Note 2	
	Low level	VIL		VSS	-	0.8	V		
	γ -voltage	V0	A		(4.06)	(4.21)	(4.36)		V
			B						
		V1	A		(3.93)	(4.08)	(4.23)		V
			B		(3.66)	(3.81)	(3.96)		V
		V2	A		(3.61)	(3.76)	(3.91)		V
			B		(2.76)	(2.91)	(3.06)		V
		V3	A		(3.30)	(3.45)	(3.60)		V
			B		(2.27)	(2.42)	(2.57)		V
		V4	A		(2.83)	(2.98)	(3.13)		V
			B		(1.86)	(2.01)	(2.16)		V
		V5	A		(2.35)	(2.50)	(2.65)		V
			B		(1.55)	(1.70)	(1.85)		V
V6	A		(2.03)	(2.18)	(2.33)	V			
	B		(1.06)	(1.21)	(1.36)	V			
V7	A		(1.57)	(1.72)	(1.87)	V			
	B		(0.66)	(0.81)	(0.96)	V			
V8	A		(1.10)	(1.25)	(1.40)	V			
	B		(0.43)	(0.58)	(0.73)	V			
V9	A		(0.52)	(0.77)	(0.92)	V			
	B		(0.26)	(0.41)	(0.56)	V			
V10	A		(0.16)	(0.31)	(0.46)	V			
	B								
Power supply current		IDD	VDD=3.3V	-	1.3	3	mA	Note 3	
		ICC	VCC=5V	-	2.0	4	mA		
		IGH	VGH=15V	-	0.3	1	mA		
		IGL	VGL=-10V	-	0.3	1	mA		
		ICOM(AC)	VCOMAC=±2.5V	-	150	250	mA	Note 3 I0-peak	

[ Note 1 ] 1) Turn on or off the power supply with simultaneously or the following sequence.

Turn on :VDD→VGL→VGH→Logic input→VCC→V0-V10

Turn off :V0-V10→VCC→Logic input→VGH→VGL→VDD

2) The input signal of "OE" Terminal(pin No.3) must be high voltage when turning on the power supply, and it is held until more than double vertical periods after VDD is turned on complete. After then it must be held low voltage.

[ Note 2 ] These are input voltage for gray scale.

Keep the following relation.

$VSS+0.1V \leq V10 \leq V9 \leq V8 \leq V7 \leq V6 \leq V5 \leq V4 \leq V3 \leq V2 \leq V1 \leq V0 \leq VCC-0.1V$

A or B voltage is selected alternately every 1 horizontal period.

[ Note 3 ] Typ. value : display pattern is 64 gray scale bar.

[ Note 4 ] VCOM AC should be alternated on VCOM DC every 1 horizontal period 1 vertical period. VCOM DC bias is adjusted so as to minimize flicker or maximum contrast every each module.

## OPTICAL CHARACTERISTICS

Ta=25 degC, VDD=3.3V, fv=60Hz

ITEM	SYMBOL	CONDITIONS		MIN	TYP	MAX	UNIT	NOTE	
		Front light	Other						
Brightness	B	On	$\phi=0$ deg.	-	(28)	-	cd/m <sup>2</sup>	Note 5,7,8	
Brightness uniformity	$\delta$ B	On	$\phi=0$ deg.	-	-	1.6	-	Note 6,7,8	
Contrast ratio	CR	On	$\phi=0$ deg.	-	(7)	-	-	Note 2,4,8	
		Off	$\phi=0$ deg.	-	(17)	-			
Viewing angle range	$\phi$	Off	CR>2	$\theta = 0$ deg.	-	(50)	-	deg.	Note 1,2,4,8
				$\theta = 90$ deg.	-	(60)	-		
				$\theta =180$ deg.	-	(50)	-		
				$\theta =270$ deg.	-	(60)	-		
Response time	Rise	tr	Off	$\phi=0$ deg.	-	10	-	ms.	Note 3,4,8
	Fall	tf			-	10	-		
White Chromaticity		x	Off	$\phi=0$ deg.		(0.32)		-	Note 4,9
		y				(0.36)			
		x	On	$\phi=0$ deg.		(0.30)		-	Note 4,8
		y				(0.30)			
Reflection Raito	R		Off	$\phi=0$ deg.	-	(17)	-	%	Note 4,10

The measuring method of the optical characteristics is shown by the following figure.

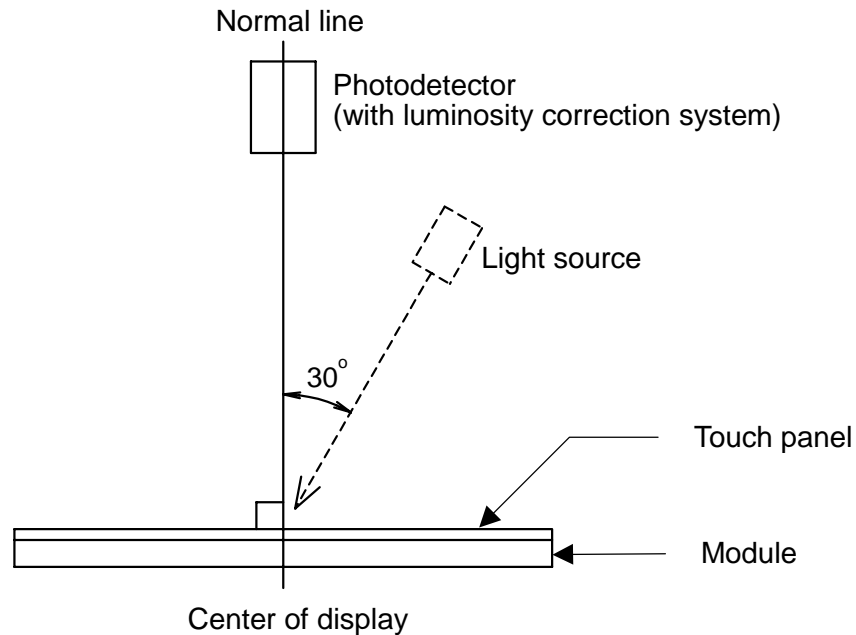

[Note 1]  $\phi$  and  $\theta$

[Note 2] Contrast ratio "CR" is defined as :

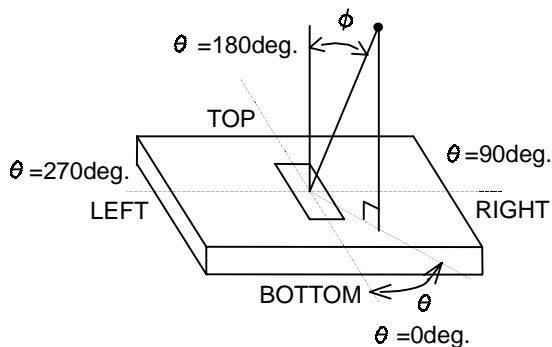

$$CR = \frac{\text{Brightness at White}}{\text{Brightness at Black}}$$

[Note 3] Response time

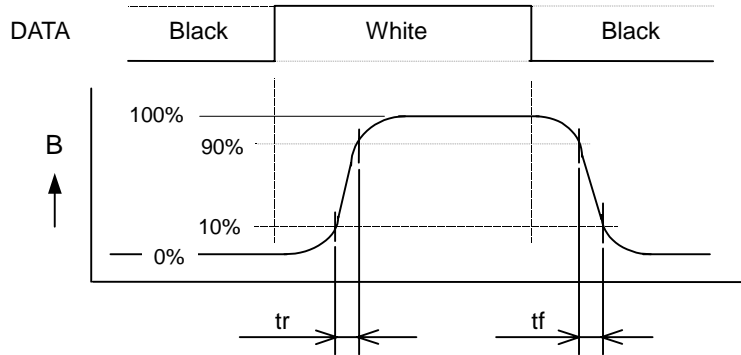

[Note 4] This shall be measured at center (point No.3 shown in Note 7).

[Note 5] The brightness shall be the average of five points. (point No.1,3,5,7,9 shown in Note 7)

[Note 6] The brightness uniformity " $\delta B$ " is defined as :

$$\delta B = \frac{\text{Maximum brightness of nine points}}{\text{Minimum brightness of nine points}}$$

[Note 7] Measurement points

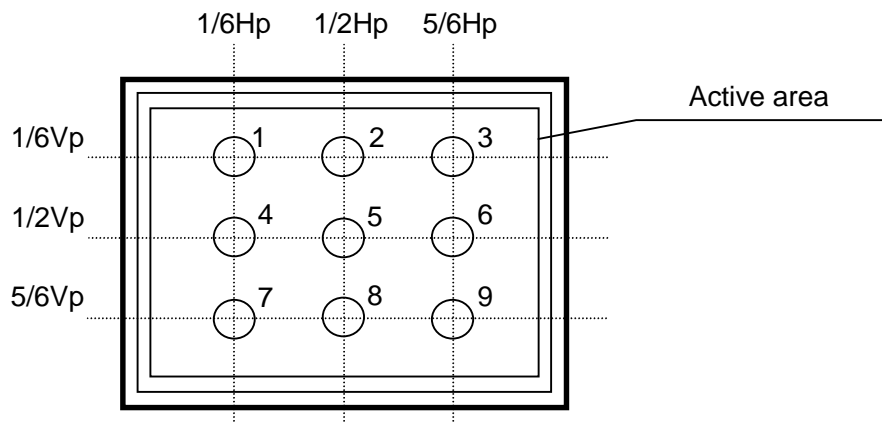

Vp: Total Number of Vertical pixel  
Hp: Total Number of horizontal pixel

[Note 8] Measurement condition (Front light)

- (1) Measurement equipment: BM-5A
- (2) Ambient temperature Ta:  $25 \pm 2$  degC
- (3) LCD: All pixels are WHITE, VDD=3.3V, fv=60Hz
- (4) Measure after 30 minutes of lamp warm up.
- (5) IL=1.4 mArms with the lamp inverter CFP-66-2 (Torisan).

[Note 9] The measurement shall be taken in a D65 light source.

[note10] Reflection Ratio is defined as :

$$R = \text{Reflectance Factor white board} \times \frac{\text{Lum avg. 5-spot}}{\text{Lum white board}}$$

## FRONTLIGHT CHARACTERISTICS

Ta=25 degC

ITEM	SYM.	CONDITION	MIN	TYP	MAX	UNIT	NOTE
Lamp voltage	VL		-	(360)	-	Vrms	IL=TBDmArms
Lamp current	IL		0.8	(1.4)	3	mArms	
Operating frequency	fL		50	60	100	kHz	Note 1
Start up voltage	VS		-	-	1000	Vrms	Ta=25 degC,Note2
Operating life	tOL		10,000	-	-	Hours	IL=1.4mArms

[Note 1] Frontlight driving conditions (operating frequency fL especially) may interfere with horizontal frequency fH, causing the beat or flicker on the display. Therefore the operating frequency fL shall be adjusted in relation to horizontal frequency fH to avoid interference.

[Note 2] The Non-Load output voltage(Vo)of the inverter should be designed to have some margin, because Vs may be increased due to the leak current in case of LCD module.

[Note 3] The inverter open voltage should be larger than start up voltage, otherwise frontlight may blinking for a moment after turns on or not be turned on. And this voltage should be applied to lamp for more than 1 second to start up, otherwise frontlight may not be turned on.

[Note 4] Average life time of Lamp will be decreased when LCD module is operating at lower temperature.

[Note 5] If driving current waveform is asymmetrical, mercury deviation inside of lamp will incline to one side and consequently abnormal lighting may occur. To prevent such unfavorable lighting, driving current waveform is asked to have unbalance rate of less than 10% and wave-height rate of less than  $\sqrt{2} \pm 10\%$ . And this driving waveform shall be confirmed in your system.

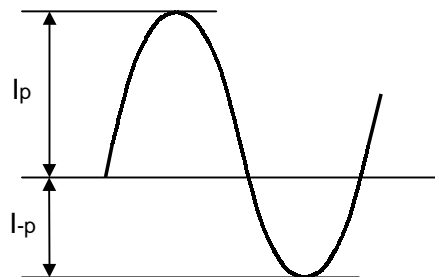

Current waveform

$$\text{Unbalance rate} = |I_p - I_{-p}| / I_L \times 100 (\%)$$

$$\text{Wave-height rate} = I_p \text{ (or } I_{-p}) / I_L$$

$I_p$  : High peak value

$I_{-p}$  : Low peak value

$I_L$  : Effective value

## TOUCH PANEL CHARACTERISTICS

Ta=25 degC

ITME		MIN	TYP	MAX	UNIT	NOTE
Input Voltage				7	V	
Resistance between terminal	X	150	-	800	$\Omega$	
	Y	150	-	800	$\Omega$	
Linearity		-	-	1.5	%	
Chattering		-	-	10	ms	
Surface hardness		3	-	-	H	
Operation force		-	30	80	gf	
Insulation resistance		10			M $\Omega$	
Transmittance		-	80	-	%	

**BLOCK DIAGRAM**

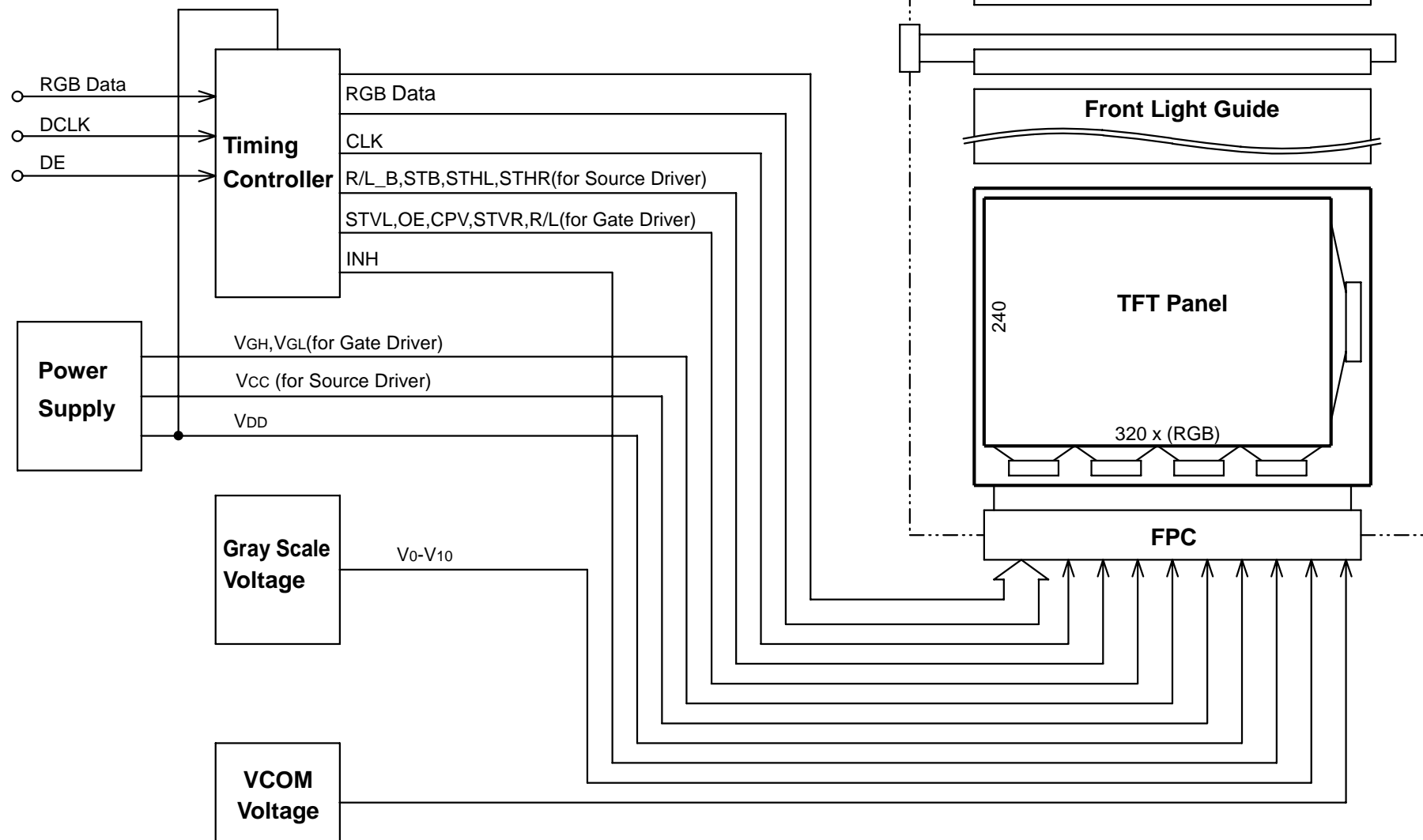



## INTERFACE PIN CONNECTIONS

### LCM : CN1

PIN NO.	SYMBOL	FUNCTION
1	VGH	Power supply of gate driver(high level)
2	STVL	Start signal of gate driver
3	OE	Output enable of gate driver
4	CPV	Clock signal of gate driver
5	VGL	Power supply of gate driver(low level)
6	VGL	Power supply of gate driver(low level)
7	STVR	Start signal of gate driver
8	GND	Ground
9	VDD	Power supply (3.3V)
10	VDD	Power supply (3.3V)
11	VDD	Power supply (3.3V)
12	R/L	Selection for vertical scanning direction
13	VCOM	Power supply of common electrode
14	VCOM	Power supply of common electrode
15	VCOM	Power supply of common electrode
16	GND	Ground
17	V10	Gray scale voltage
18	V8	Gray scale voltage
19	V6	Gray scale voltage
20	V4	Gray scale voltage
21	V2	Gray scale voltage
22	V0	Gray scale voltage
23	GND	Ground
24	B0	Blue data (LSB)
25	B1	Blue data
26	B2	Blue data
27	B3	Blue data
28	B4	Blue data
29	B5	Blue data (MSB)
30	GND	Ground
31	G0	Green data (LSB)
32	G1	Green data
33	G2	Green data
34	G3	Green data
35	G4	Green data
36	G5	Green data (MSB)
37	GND	Ground
38	R0	Red data (LSB)
39	R1	Red data
40	R2	Red data
41	R3	Red data
42	R4	Red data
43	R5	Red data (MSB)
44	VCC	Power supply (5V)
45	VCC	Power supply (5V)
46	GND	Ground
47	R/L_B	Selection for horizontal scanning direction
48	STB	Data latch signal of source driver
49	INH	Control signal of source driver
50	STHL	Start signal of source driver

PIN NO.	SYMBOL	FUNCTION
51	GND	Ground
52	CLK	Data clock
53	GND	Ground
54	STHR	Start signal of source driver
55	V1	Gray scale voltage
56	V3	Gray scale voltage
57	V5	Gray scale voltage
58	V7	Gray scale voltage
59	V9	Gray scale voltage
60	GND	Ground

CN1 : FPC(Pitch 0.3mm, Cross arrangement)  
Suitable mating connector: FF0260SA1(JAE)

[Note 1] Valid synchronous signals are DCLK and DE. HSYNC and VSYNC are not used.

[Note 2] Section for vertical scanning direction.

R/L	STVR	STVL	Scanning direction
High	Input	Output	Normal scanning Vp 240→Vp1
Low	Output	Input	Inverted scanning Vp 1→Vp 240

[Note 3] Section for horizontal scanning direction.

R/L_B	STHR	STHL	Scanning direction
High	Input	Output	Normal scanning Hp 1→Hp 320
Low	Output	Input	Inverter scanning Hp 320→Hp 1

### Back Light : FLCN1

PIN NO.	SYMBOL	FUNCTION
1	H.V	High voltage for CFL
2	N.C.	No connection
3	LGND	Low voltage for CFL

FLCN1 : BHR-03VS-1 (JST)  
Suitable mating connector: SM02(8.0)B-BHS-1 (JST)

### Touch Panel : TPCN1

PIN NO.	SYMBOL
1	Left
2	Top
3	Right
4	Bottom

TPCN1:FPC(Pitch 1.0mm)

**INTERFACE SIGNAL TIMING PARAMETERS ( DE\_MODE )**

PARAMETER	SYMBOL	MIN	TYP	MAX	UNIT	NOTE	
DCLK	Frequency	fCLK	-	-	10	MHz	tCLK=1/fCLK
	Width-Low	twCL	(10)	-	-	ns	
	Width-High	twCH	(10)	-	-	ns	
	Rise/fall Time	trCLK,tfCLK	-	-	40	ns	
	Duty	D	(0.40)	0.50	(0.60)	-	D=tCLKL/tCLK
DE	Setup Time	tSI	(10)	-	(17)	ns	for DCLK
	Hold Time	tHI	(10)	-	(17)	ns	
	Rise/Fall Time	tir,tif	-	-	40	ns	
	Horiz. Period	tHP	341	-	640	tCLK	
	Horiz. DE	tHDE	-	320	-	tCLK	
	Vert. Period	tVP	NVDE+5	-	4095	tHP	fv=60Hz Typ.
	Vert. DE	nVDE	128	240	-	n	
DATA	Setup Time	tSD	(10)	-	-	ns	for DCLK
	Hold Time	tHD	(10)	-	-	ns	
	Rise/Fall Time	tDr,tDf	-	-	40	ns	

[Note 1] f<sub>H</sub> (Horizontal Frequency) = 1/t<sub>HP</sub>  
 f<sub>V</sub> (Vertical Frequency) = 1/t<sub>VP</sub>

**INTERFACE SIGNAL TIMING DIAGRAM ( DE\_MODE )**

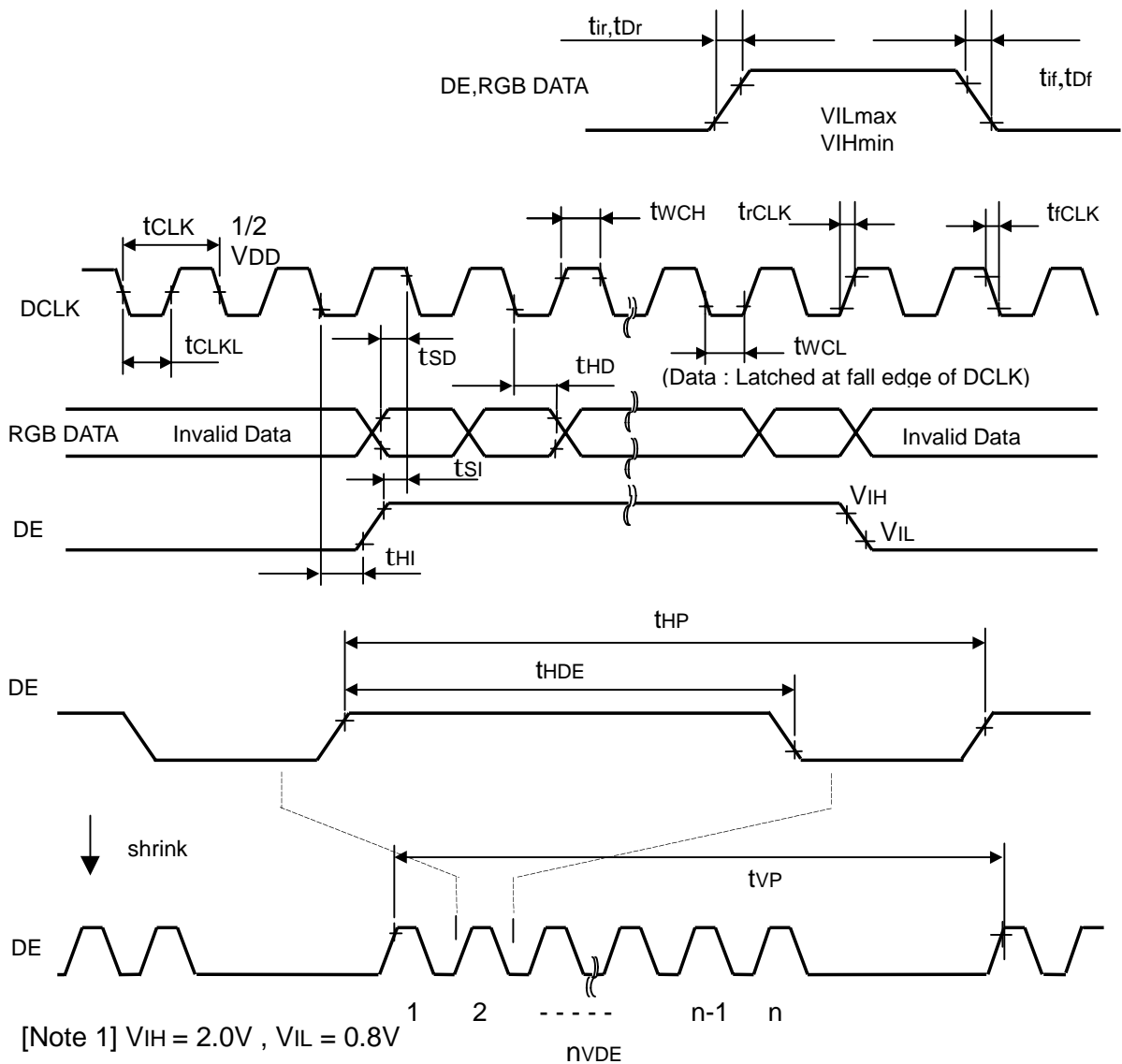

**RELATIONSHIP BETWEEN INPUT DATA AND DISPLAY COLOR**

DISPLAY COLOR \ INPUT DATA		R DATA						G DATA						B DATA					
		MSB			LSB			MSB			LSB			MSB			LSB		
		R5	R4	R3	R2	R1	R0	G5	G4	G3	G2	G1	G0	B5	B4	B3	B2	B1	B0
BASIC COLOR	BLACK	L	L	L	L	L	L	L	L	L	L	L	L	L	L	L	L	L	L
	RED(63)	H	H	H	H	H	H	L	L	L	L	L	L	L	L	L	L	L	L
	GREEN(63)	L	L	L	L	L	L	H	H	H	H	H	H	L	L	L	L	L	L
	BLUE(63)	L	L	L	L	L	L	L	L	L	L	L	L	H	H	H	H	H	H
	CYAN	L	L	L	L	L	L	H	H	H	H	H	H	H	H	H	H	H	H
	MAGENTA	H	H	H	H	H	H	L	L	L	L	L	L	L	L	L	L	L	L
	YELLOW	H	H	H	H	H	H	H	H	H	H	H	H	L	L	L	L	L	L
	WHITE	H	H	H	H	H	H	H	H	H	H	H	H	H	H	H	H	H	H
RED	BLACK	L	L	L	L	L	L	L	L	L	L	L	L	L	L	L	L	L	L
	RED(1)	L	L	L	L	L	H	L	L	L	L	L	L	L	L	L	L	L	L
	RED(2)	L	L	L	L	H	L	L	L	L	L	L	L	L	L	L	L	L	L
	⋮																		
	⋮																		
	⋮																		
	RED(61)	H	H	H	H	L	H	L	L	L	L	L	L	L	L	L	L	L	L
	RED(62)	H	H	H	H	H	L	L	L	L	L	L	L	L	L	L	L	L	L
RED(63)	H	H	H	H	H	H	L	L	L	L	L	L	L	L	L	L	L	L	
GREEN	BLACK	L	L	L	L	L	L	L	L	L	L	L	L	L	L	L	L	L	L
	GREEN(1)	L	L	L	L	L	L	L	L	L	L	L	H	L	L	L	L	L	L
	GREEN(2)	L	L	L	L	L	L	L	L	L	L	H	L	L	L	L	L	L	L
	⋮																		
	⋮																		
	⋮																		
	GREEN(61)	L	L	L	L	L	L	H	H	H	H	L	H	L	L	L	L	L	L
	GREEN(62)	L	L	L	L	L	L	H	H	H	H	H	L	L	L	L	L	L	L
GREEN(63)	L	L	L	L	L	L	H	H	H	H	H	H	L	L	L	L	L	L	
BLUE	BLACK	L	L	L	L	L	L	L	L	L	L	L	L	L	L	L	L	L	L
	BLUE(1)	L	L	L	L	L	L	L	L	L	L	L	L	L	L	L	L	L	H
	BLUE(2)	L	L	L	L	L	L	L	L	L	L	L	L	L	L	L	L	H	L
	⋮																		
	⋮																		
	⋮																		
	BLUE(61)	L	L	L	L	L	L	L	L	L	L	L	L	H	H	H	H	L	H
	BLUE(62)	L	L	L	L	L	L	L	L	L	L	L	L	H	H	H	H	H	L
BLUE(63)	L	L	L	L	L	L	L	L	L	L	L	L	H	H	H	H	H	H	

[Note 1] Color(n) --- 'n' indicates gray scale step.

**RELATIONSHIP BETWEEN INPUT DATA AND DISPLAY POSITION**  
LEFT

1-1	1-2	1-3	⋯	1-319	1-320	
2-1	2-2	<div style="display: flex; justify-content: center; align-items: center; gap: 20px;"> <div style="border: 1px solid black; padding: 2px;">Vp · Hp</div> <div style="border: 1px solid black; padding: 2px;">R</div> <div style="border: 1px solid black; padding: 2px;">G</div> <div style="border: 1px solid black; padding: 2px;">B</div> </div>				2-320
3-1						
⋮						
⋮						
239-1				239-320		
240-1	240-2	⋯	240-319	240-320		

TOP

## POWER ON/OFF SEQUENCE REQUIREMENT

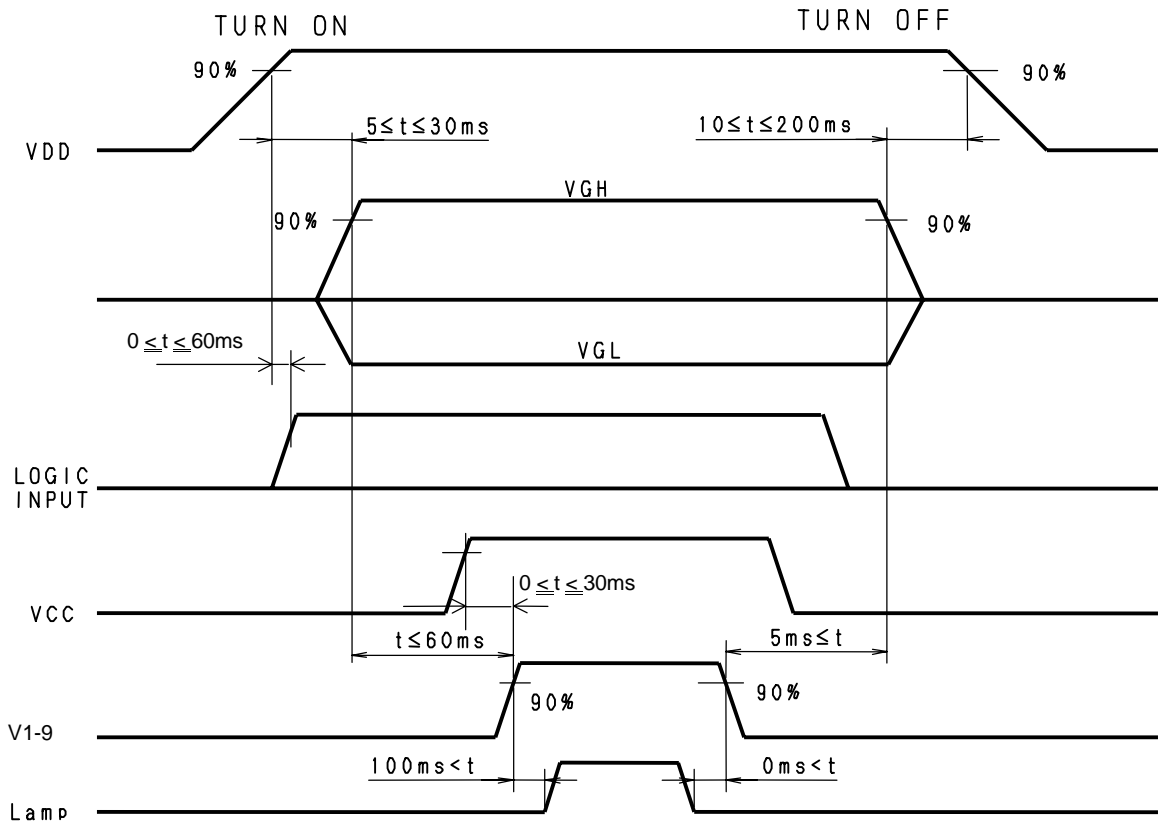

Turn on :VDD → VGL → VGH → Logic input → VCC → V1-V9



Turn off :V1-V9 → VCC → Logic input → VGH → VGL → VDD

When the power is off, logic input must be kept at either low level or high impedance.

***LABEL***

Date code and serial number (module).

<Label>

Type Number	<b>TORISAN TFT-LCM</b>		
	<b><u>TM038QV-67A02A</u></b>		
Serial Number	*****1628		Production Date (Ex) Jun.28,2001
	 ***** 		
	MADE IN JAPAN		

Production Date

Month	: Code	Month	: Code
Jan.	: 1	Jul.	: 7
Feb.	: 2	Aug.	: 8
Mar.	: 3	Sep.	: 9
Apr.	: 4	Oct.	: X
May	: 5	Nov.	: Y
Jun.	: 6	Dec.	: Z

Label position

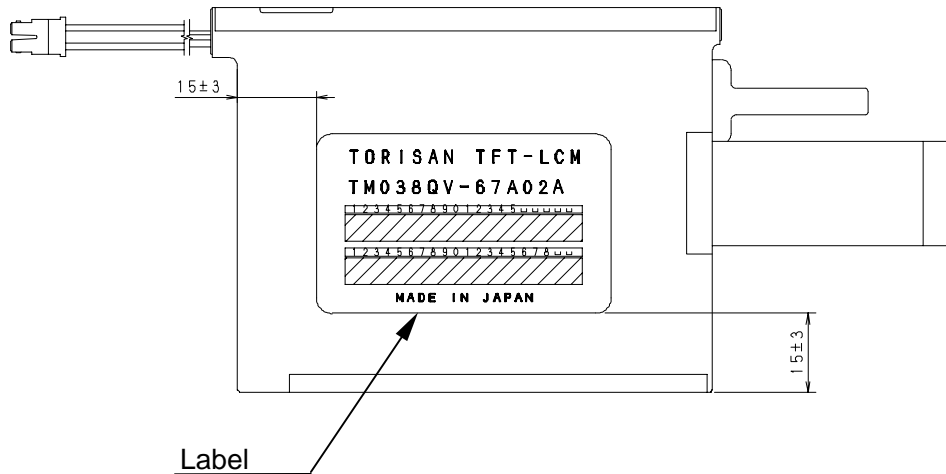

## ***PRECAUTIONS (INSTRUCTIONS FOR SAFE AND PROPER USE)***

### **1. Instructions for safety**

- (1) Please do not disassemble or modify LCD module to avoid the possibility of electric shock, damage of electronic components, scratch at display surface and invasion of foreign particles. In addition, such activity may result in fire accident due to burning of electronic component.  
LCD module disassembled or modified by customer is out of warranty.
- (2) Please be careful in handling of LCD module with broken glass.  
When the display glass breaks, please pay attention not to injure your fingers. The display surface has the plastic film attached, which prevents dispersion of glass pieces, however touching broken edge will injure your fingers. Also Lamp (Cold Cathode Fluorescent Lamp) is made of glass, therefore please pay attention in the same way.
- (3) Please do not touch the fluid flown out of broken display glass.  
If the fluid should stick to hand or clothes, wipe off with soap or alcohol immediately and then wash it with water. If the fluid should get in eyes, wash eyes immediately with pure water for more than 15 minutes and then consult the doctor.
- (4) Please make secure connection of Lamp connector.  
Please make sure that Lamp connector from LCD module is connected with output connector on inverter circuit securely. Poor connection may cause smoke or fire accident due to high voltage in circuit. If connection may not be secure, please switch off the power supply for LCD module and Lamp and then make secure connection.  
Please do not make connection with another connector than recommended mating connector.
- (5) Lamp contains mercury inside. Please follow regulations or rules established by local autonomy at its disposal.
- (6) Please be careful to electric shock.  
Before handling LCD module, please switch off the power supply.  
Since high voltage is applied to Lamp terminal, cable, connector and inverter circuit in operation mode, touching them will cause electric shock.

### **2. Instructions for designing**

- (1) Mounting of LCD  
Please fix LCD module at all mounting flanges shown in this specification for installation onto system. The used screws should have proper dimensions.  
Furthermore, designing of mounting parts should be adequate so that LCD module is not warped or twisted, to achieve good display quality.
- (2) Mounting of LCD  
Please give careful consideration in designing which doesn't press down a Touch panel for installation onto system. If must be press it down that please leave it from the Bezel opening area more than 2mm.
- (2) Polarity of power supply for Lamp  
Please give careful consideration in designing so that each polar of cable should be connected correctly at assembling (i.e. high voltage side is connected to high voltage side and low voltage side is connected to low voltage side). Since longer Lamp cable may cause insatiable start-up of Lamp and reduction of brightness, please make cable short as much as possible.

- (3) Designing of power supply circuit for Lamp  
Please design the circuit so that high voltage output can be kept for more than 1 second. The shorter time may not start up Lamp. The driving inverter circuit is recommended to be the type which Lamp current can be controlled.  
The type which voltage is controlled is not recommended, because it may cause big current under high temperature and insatiable start-up of Lamp under low temperature.
- (4) Heat radiation  
Lamp generates heat at lighting and causes temperature rise inside system. Therefore, designing to radiate heat like radiation slits at cabinet is recommended to meet the specified operating temperature range for LCD module.
- (5) Noise on power line  
Spike noise contained in power line causes abnormal operation of driving circuit and abnormal display. To avoid it, spike noise should be suppressed below VDD +/- 200mVp-p. (In any case, absolute maximum rating should be kept.)
- (6) Power sequence  
Before LCD module is switched on, please make sure that power supply and input signals of system, testing equipment, etc. meet the recommended power sequence.
- (7) Absolute maximum rating  
Absolute maximum rating specified in this specification has to be kept in any case. It shows the maximum that cannot be exceeded.  
Exceeding it may cause burning or non-recoverable break of electronic components in circuit. Please make system design so that absolute maximum rating is not exceeded even if ambient temperature, input signal and components are varied.
- (8) Protection for power supply  
Please study to adapt protection for power supply against trouble of LCD module, depending on usage condition of system.
- (9) Protection against electric shock  
High voltage is applied to Lamp connector, inverter circuit and Lamp at lighting. Please make design not to expose or be accessible to such high voltage parts to avoid electric shock.
- (10) Protection cover and cut-off filter for ultraviolet rays  
When LCD module is used under severe condition like outdoor, it is recommended to use transparent protection cover over display surface to avoid scratches and invasion of dust and water. In addition, when LCD module is exposed to direct sun light for long time, use of cut-off filter for ultraviolet rays is also recommended. Please be careful not to get condensation.

### **3. Instructions for use and handling**

- (1) Protection against Static electricity  
Semiconductors are easily damaged by static discharge. LCD module should be handled on conductive mat by person grounded with wrist strap etc. to avoid getting static electricity. Please be careful not to generate static electricity during operation.



- (2) Protection against dust and stain  
LCD module should be handled in circumstance as clean as possible.  
It is recommended to wear fingerstalls or ductless and soft gloves before handling to avoid getting dust or stain on display surface.
- (3) Protection film for display surface  
It is recommended to remove protection film at nearly final process of assembling to avoid getting scratch or dust. To remove film, please pick up its edge with dull-head tweezers or cellophane tape at first and then remove film gradually taking more than 3 seconds. If film is removed quickly, static electricity may be generated and may damage semiconductors or electronic components.
- (4) Contamination of display surface  
When display surface of Touch panel is contaminated, please wipe the surface softly with cotton swab or clean cloth.
- (5) Water drop on LCD surface  
Please do not leave LCD module with water drop. When the display surface gets water drop, please wipe it off with cotton swab or soft cloth immediately, otherwise display surface will be deteriorated.  
If water gets in inside of LCD module, circuit may be damaged.
- (6) Please make sure that LCD module is not warped or twisted at installation into system. Even temporary warp or twist may be the cause for failure.
- (7) Mechanical stress  
Please be careful not to apply strong mechanical stress like drop or shock to LCD module. Such stress may cause break of display glass and Lamp or may be the cause for failure.
- (8) Pressure to display surface  
Please be careful not to apply strong pressure to display surface. Such pressure may cause scratches at surface or may be the cause of failure.
- (9) Protection against scratch  
Please be careful not to hit, press or rub the display surface with hard material like tools. In addition, please do not put heavy or hard material on display surface, and do not stack LCD modules. Touch Panel at front surface can be easily scratched.
- (10) Plugging in of connector  
Please be careful not to apply strong stress to connector part of LCD module at plugging in or out, because strong stress may damage the inside connection. At plugging in connector, place LCD module on the flat surface and hold the backside of connector on LCD module. Please make sure that connector is plugged in correctly. Insecure connection may be the cause for failure during operation.  
In addition, please be careful not to put the connecting cable between cabinet of system and LCD module at installing LCD module into system.
- (11) Handling of Lamp cable and FPC (Flexible Printed Circuit)  
Please be careful not to pull or scratch Lamp cable, because Lamp or soldered part of cable may be damaged consequently.  
Also FPC should not be pulled or scratched.
- (12) Switching off before plugging in connector  
Please make sure that power is switched off before plugging in connector.  
If power is on at plugging in or out, circuit of LCD module may be damaged.  
When LCD is switched on for test or inspection, please make sure that power supply and input signals of driving system meet the specified power sequence.

- (13) Temperature dependence of LCD display  
Response speed (optical response) of LCD display is dependent on temperature. Under low temperature, response speed is slower.  
Also brightness and chromaticity change slightly depending on temperature.
- (14) Slow light-up of Lamp under low temperature  
Under low temperature, start-up of Lamp gets difficult. (The time from switch-on to stable lighting becomes longer.)  
As characteristic of Lamp, operation under low temperature makes the life time shorter. To avoid this, it is recommended to operate under normal temperature.
- (15) Condensation  
LCD module may get condensation on its display surface and inside in the circumstance where temperature changes much in short time.  
Condensation can cause deterioration or failure. Therefore, please be careful not to get condensation.
- (16) Remaining of image  
Displaying the same pattern for long time may cause remaining of image even after changing the pattern. This is not failure but will disappear with time.

#### **4. Instructions for storage and transportation**

- (1) Storage  
Please store LCD module in the dark place of room temperature and low humidity in original packing condition, to avoid condensation that may cause failure.  
Since sudden temperature change may cause condensation, please store in circumstance of stable temperature.
- (2) Stacking number  
Since excessive weight causes deformation and damage of carton box, please stack only up to the number stated on carton box for storage and transportation.
- (3) Handling  
Since LCD module consists of glass and precise electronic components, it will be damaged by excessive shock and drop. Therefore, please handle the carton box carefully to minimize shock at loading, reloading and transportation.

**TENTATIVE**

■ Outer Dimensions  
(Front Side)

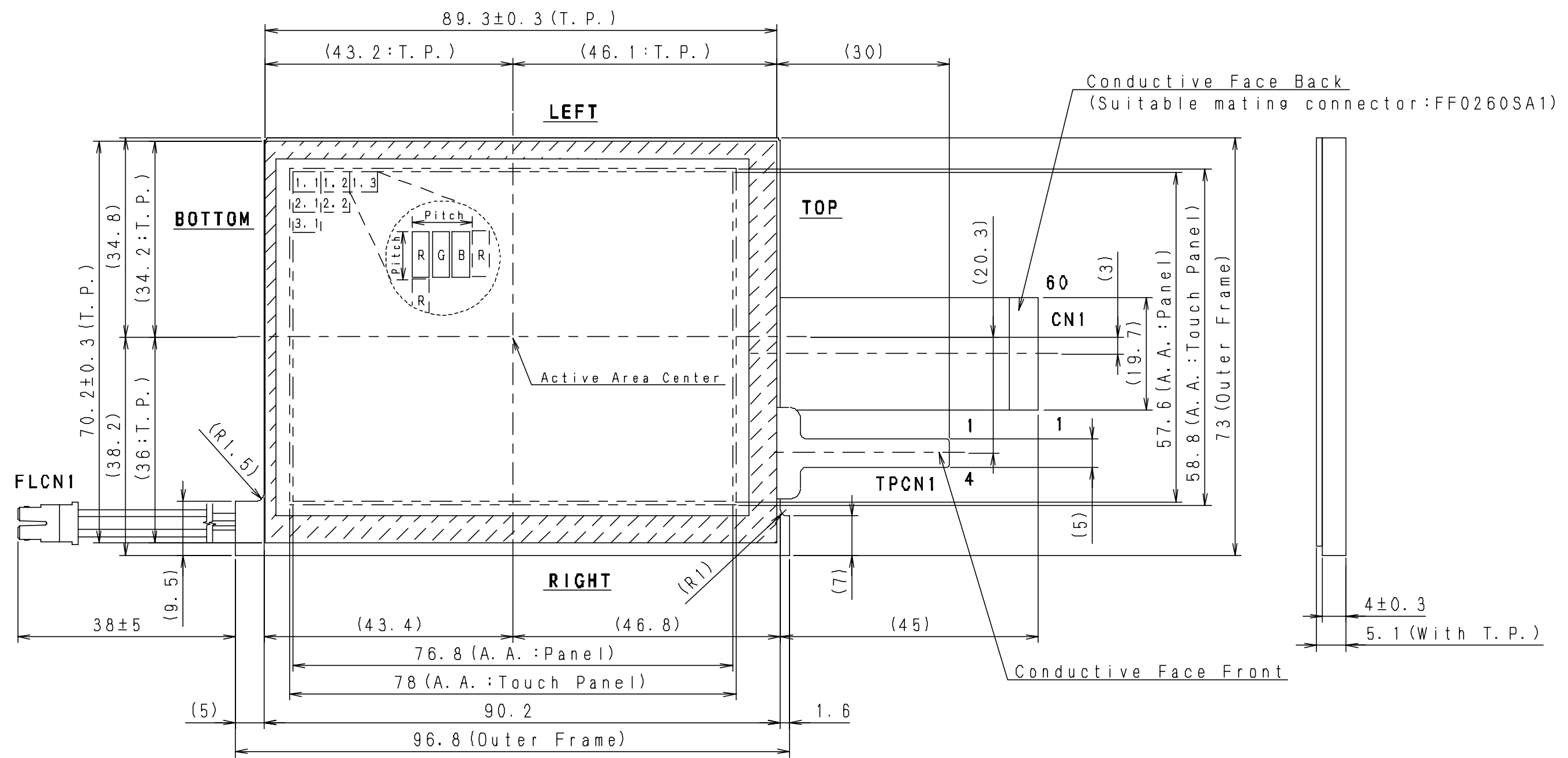

Touch Panel Pin Assignment

1	LEFT
2	TOP
3	RIGHT
4	BOTTOM

FLCN1 : BHSR-02VS-1 (JST)

Note1: Unspecified dimension tolerances are ±0.5mm.

Unit : mm

■ Outer Dimensions  
( Back Side )

**TENTATIVE**

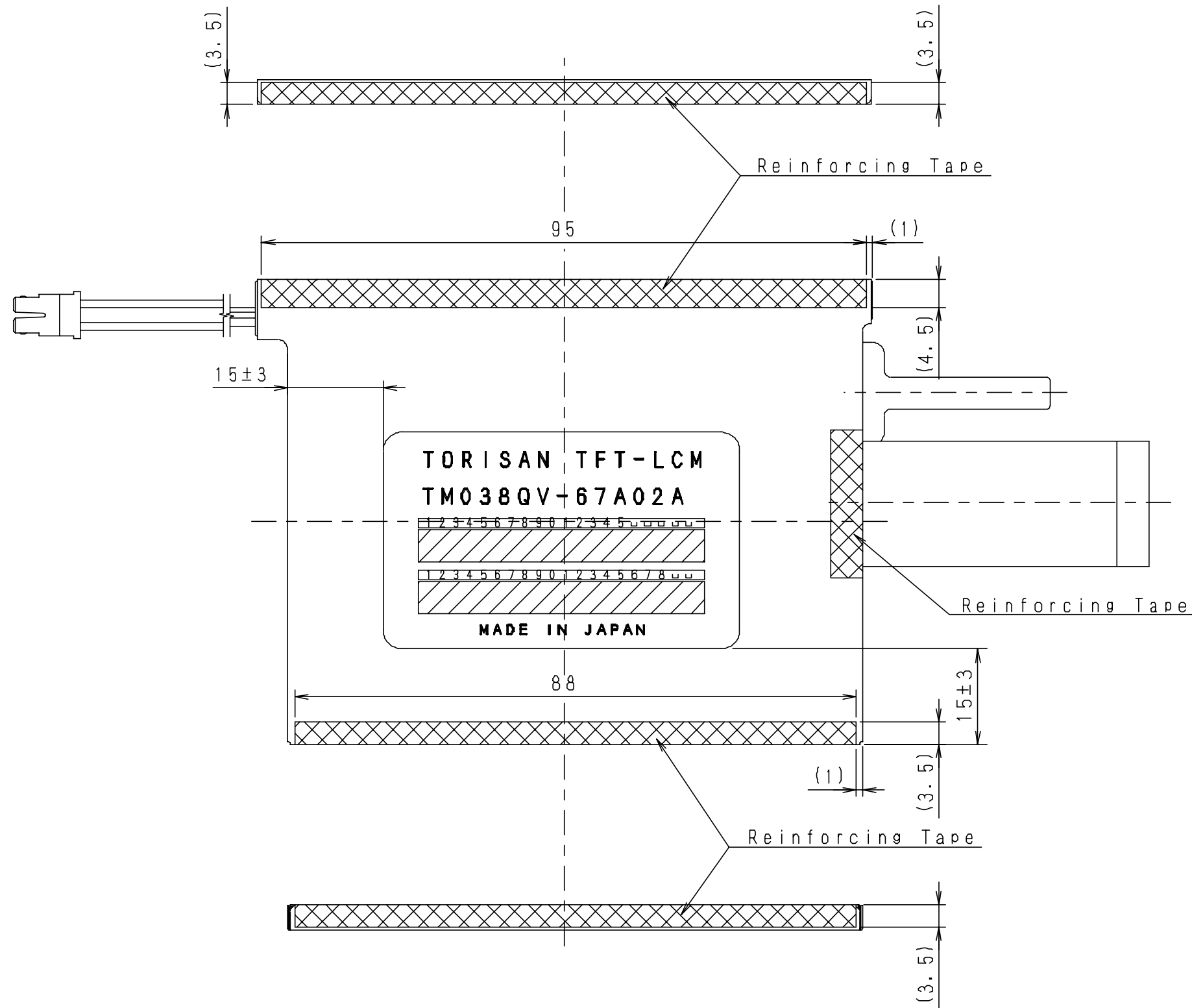

Note1: Unspecified dimension tolerances are ±0.5mm.

Unit: mm