

Tentative Specification
Preliminary Specification
Approval Specification

MODEL NO.: G170J1
SUFFIX: LE1

Customer: TESLA	
APPROVED BY	SIGNATURE
<u>Name / Title</u>	_____
Note	

Please return 1 copy for your confirmation with your signature and comments.	

Approved By	Checked By	Prepared By

- CONTENTS -

REVISION HISTORY	-----	3
1. GENERAL DESCRIPTION	-----	5
1.1 OVERVIEW		
1.2 FEATURES		
1.3 APPLICATION		
1.4 GENERAL SPECIFICATIONS		
1.5 MECHANICAL SPECIFICATIONS		
2. ABSOLUTE MAXIMUM RATINGS	-----	6
2.1 ABSOLUTE RATINGS OF ENVIRONMENT		
2.2 ELECTRICAL ABSOLUTE RATINGS		
2.2.1 TFT LCD MODULE		
2.2.2 LED CONVERTER		
3. ELECTRICAL CHARACTERISTICS	-----	8
3.1 TFT LCD MODULE		
3.2 LED CONVERTER		
4. BLOCK DIAGRAM	-----	11
4.1 TFT LCD MODULE		
5. INTERFACE PIN ASSIGNMENT	-----	12
5.1 TFT LCD MODULE		
5.2 BACKLIGHT UNIT		
5.3 COLOR DATA INPUT ASSIGNMENT		
6. INTERFACE TIMING	-----	14
6.1 INPUT SIGNAL TIMING SPECIFICATIONS		
6.2 POWER ON/OFF SEQUENCE		
6.3 THE INPUT DATA FORMAT		
7. OPTICAL CHARACTERISTICS	-----	17
7.1 TEST CONDITIONS		
7.2 OPTICAL SPECIFICATIONS		
8. RELIABILITY TEST CRITERIA	-----	21
9. PACKING	-----	22
9.1 PACKING SPECIFICATIONS		
9.2 PACKING METHODS		
10. DEFINITION OF LABELS	-----	24
10.1 CMO MODULE LABEL		
11. PRECAUTIONS	-----	25
11.1 ASSEMBLY AND HANDLING PRECAUTIONS		
11.2 SAFETY PRECAUTIONS		
12. MECHANICAL CHARACTERISTIC	-----	26

REVISION HISTORY

Version	Date	Section	Description
1.0	2010.7.28	All	Preliminary spec was first issued
1.1	2010.12.27	1.4	Total power consumption 25.2W -> 24.45W
		3.1	Power supply current : Min. 900mA -> 800mA Min. 400mA -> 350mA White: Typ. 1000mA -> 850mA Black: Typ. 500mA -> 400mA Max. 1100mA -> 900mA Max. 600mA -> 450mA Power consumption 5W -> 4.25W
		5.1	Note (1) Connector Part No. :STARTCONN (093G30-B0001A) -> MOLEX (5018643091)
		5.2	Update BLACKLIGHT UNIT (Converter connector pin) table Note(1) Connector Part No. :91208-01001(ACES) -> MOLEX (436501013) Delete Note(2)
		6.1	Horizontal Active Display Term: Th 1968 -> 2000 Thb 48 -> 80
		6.2	Note(3) T6 Min. 20ms -> 200ms T7 Max. 300ms -> 100ms
		7.2	Contrast Ratio CR : Min. 900 -> 1500 Typ. 1200 -> 2000 Response Time: TR Typ. 14ms -> 20 ms Max. 19ms -> 25ms TF Typ. 11ms -> 9 ms Max. 16ms -> 15ms
		8	Update Reliability Test Criteria
		12	Updated Mechanical Characteristic
1.2	2011.5.25	1.5	Module size Depth(D) : Min. 16.5 -> 18.28 mm Typ. 16.8 -> 18.58 mm Max. 17.1 -> 18.88 mm Weight : Typ. 1465 -> 1650 g Max. 1538 -> 1732 g

		6.1	DCLK Frequency : Typ. 128.44 -> 154.13 MHz Max. 141.28 -> 159.26 MHz Note (2) Frame rate is 60 Hz
		9.1	(3) Weight : 21 -> 22.1 kg
		9.2	Updated PACKING METHOD
		12	Updated Mechanical Characteristic

1. GENERAL DESCRIPTION

1.1 OVERVIEW

G170J1- LE1 is a 17" TFT Liquid Crystal Display module with LED backlight unit and 30-pin-and-1ch LVDS interface. This product supports 1920 x 1200 WUXGA format and can display true 16.2M colors (6-bits colors with FRC). The converter module for LED backlight is built-in.

1.2 FEATURES

- Excellent brightness (600 nits)
- High color saturation NTSC 70%
- WUXGA (1920 x 1200 pixels) resolution
- DE (Data Enable) only mode
- LVDS (Low Voltage Differential Signaling) interface
- Ultra wide viewing angle: 176(H)/ 176(V) (CR>10)
- Wide operation and storage temperature range

1.3 APPLICATION

- TFT LCD monitor for Industrial application

1.4 GENERAL SPECIFICATIONS

Item	Specification	Unit	Note
Active Area	365.76 (H) x 228.6 (V)	mm	(1)
Bezel Opening Area	369 (H) x 231.8 (V)	mm	
Driver Element	a-si TFT active matrix	-	-
Pixel Number	1920 x R.G.B. x 1200	pixel	-
Pixel Pitch	0.1905 (H) x 0.1905 (V)	mm	-
Pixel Arrangement	RGB vertical stripe	-	-
Display Colors	16.2 M	color	-
Display Operation Mode	Transmissive mode / Normally black	-	-
Surface Treatment	Glare	-	-
Total power consumption(typ)	(24.45)	W	typ

Note (1) Please refer to the attached drawings for more information of front and back outline dimensions.

1.5 MECHANICAL SPECIFICATIONS

Item	Min.	Typ.	Max.	Unit	Note	
Module Size	Horizontal (H)	(386.3)	(386.8)	(387.3)	mm	(1)
	Vertical (V)	(250.3)	(250.8)	(251.3)	mm	
	Depth (D)	(18.28)	(18.58)	(18.88)	mm	-
Weight	-	(1650)	(1700)	g	-	

Note (1) Please refer to the attached drawings for more information of front and back outline dimensions.

2. ABSOLUTE MAXIMUM RATINGS

2.1 ABSOLUTE RATINGS OF ENVIRONMENT

Item	Symbol	Value		Unit	Note
		Min.	Max.		
Operating Ambient Temperature	T _{OP}	-30	+80	°C	
Storage Temperature	T _{ST}	-40	+90	°C	

Note (1) Temperature and relative humidity range is shown in the figure below.

- (a) 90 %RH Max. (Ta ≤ 40 °C).
- (b) Wet-bulb temperature should be 39 °C Max. (Ta > 40 °C).
- (c) No condensation

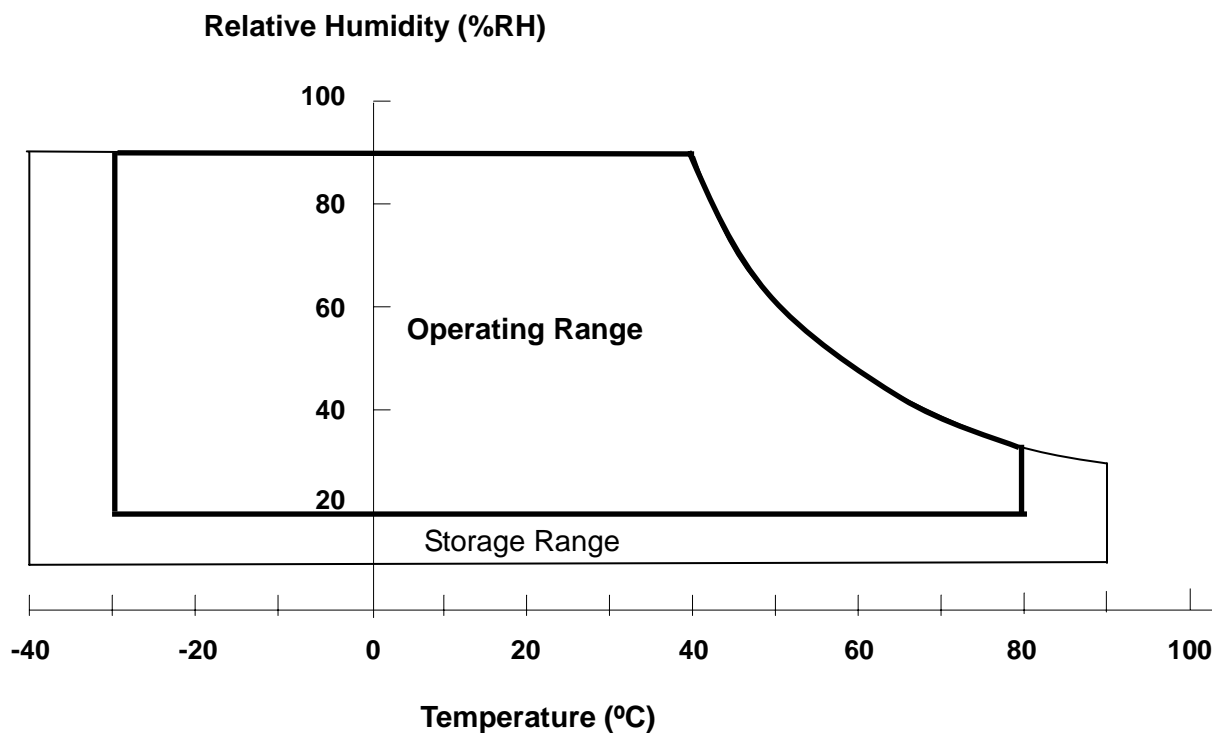

2.2 ELECTRICAL ABSOLUTE RATINGS

2.2.1 TFT LCD MODULE

Item	Symbol	Value		Unit	Note
		Min.	Max.		
Power Supply Voltage	VCC	(-0.3)	(7)	V	(1)

2.2.2 LED CONVERTER

Item	Symbol	Value		Unit	Note
		Min.	Max.		
Converter Voltage	V_i	(-0.3)	(24)	V	(1), (2)
Enable Voltage	EN	---	(5.5)	V	
Backlight Adjust	ADJ	---	(5.5)	V	

Note (1) Permanent damage to the device may occur if maximum values are exceeded. Function operation should be restricted to the conditions described under Normal Operating Conditions.

Note (2) Specified values are for LED light bar (Refer to 3.2 for further information).

3. ELECTRICAL CHARACTERISTICS

3.1 TFT LCD MODULE

Ta = 25 ± 2 °C

Parameter	Symbol	Value			Unit	Note
		Min.	Typ.	Max.		
Power Supply Voltage	V _{CC}	(4.5)	(5)	(5.5)	V	(1)
Rush Current	I _{RUSH}	-	-	(3.0)	A	(2)
Power Supply Current	White	(800)	(850)	(900)	mA	(3)
	Black	(350)	(400)	(450)	mA	
Power Consumption	P _L	---	(4.25)	---	W	
LVDS differential input voltage	VID	(100)	-	(600)	mV	-
LVDS common input voltage	V _{ICM}	(0.7)	-	(1.6)	V	-

Note (1) The assembly should be always operated within above ranges.

Note (2) Measurement Conditions:

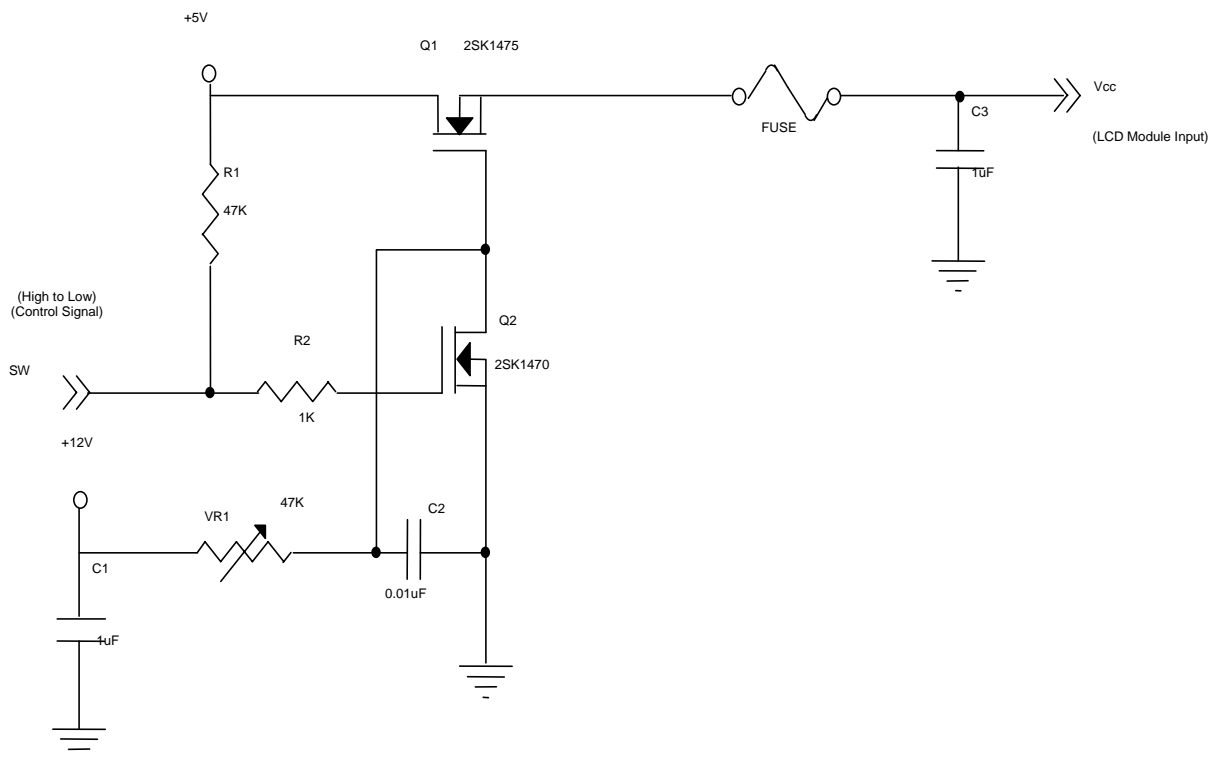

VCC rising time is 470us

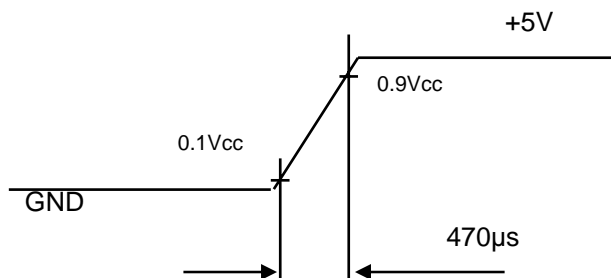

Note (3) The specified power supply current is under the conditions at $V_{CC} = 5\text{ V}$, $T_a = 25 \pm 2\text{ }^\circ\text{C}$, $f_v = 60\text{ Hz}$, whereas a power dissipation check pattern below is displayed.

a. White Pattern



Active Area

b. Black Pattern



Active Area

c. Vertical Stripe Pattern

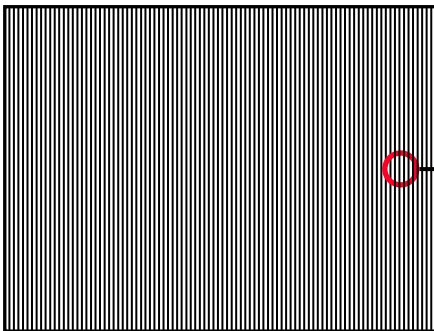

Active Area

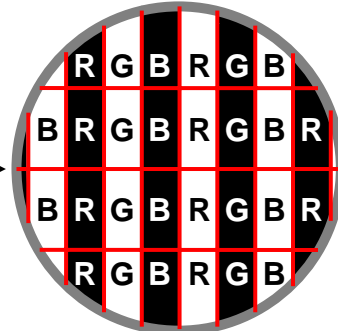

3.2 LED CONVERTER

$T_a = 25 \pm 2\text{ }^\circ\text{C}$

Parameter	Symbol	Value			Unit	Note
		Min.	Typ.	Max.		
Converter Power Supply Voltage	V_i	(10.8)	(12.0)	(13.2)	V	(Duty 100%)
Converter Power Supply Current	I_i	---	(1.68)	---	A	@ $V_i = 12\text{ V}$ (Duty 100%)
LED Power Consumption	P_{LED}	---	(20.2)	---	W	@ $V_i = 12\text{ V}$ (Duty 100%)
EN Control Level	Backlight on	(2.0)	---	(3.3)	V	
	Backlight off	(0)	---	(0.8)	V	
PWM Control Level	PWM High Level	(2.0)	---	(3.3)	V	
	PWM Low Level	(0)	---	(0.15)	V	
PWM Control Duty Ratio		(5)		(100)	%	
PWM Control Frequency	f_{PWM}	(190)	(200)	(210)	Hz	
LED Life Time	L_L	30,000			Hrs	(2)

Note (1) LED current is measured by utilizing a high frequency current meter as shown below:

Note (2) The lifetime of LED is defined as the time when it continues to operate under the conditions at

$T_a = 25 \pm 2$ and $I_{LED} = 20mA_{DC}$ (LED forward current) until the brightness becomes 50% of its original value.

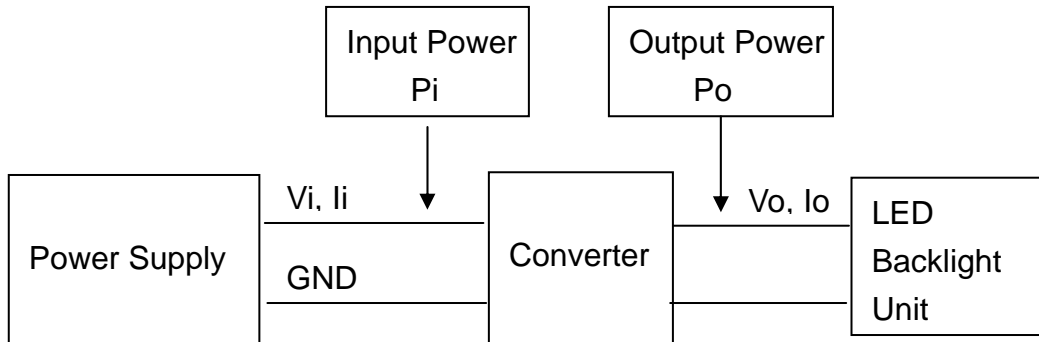

LED BL Block Diagram

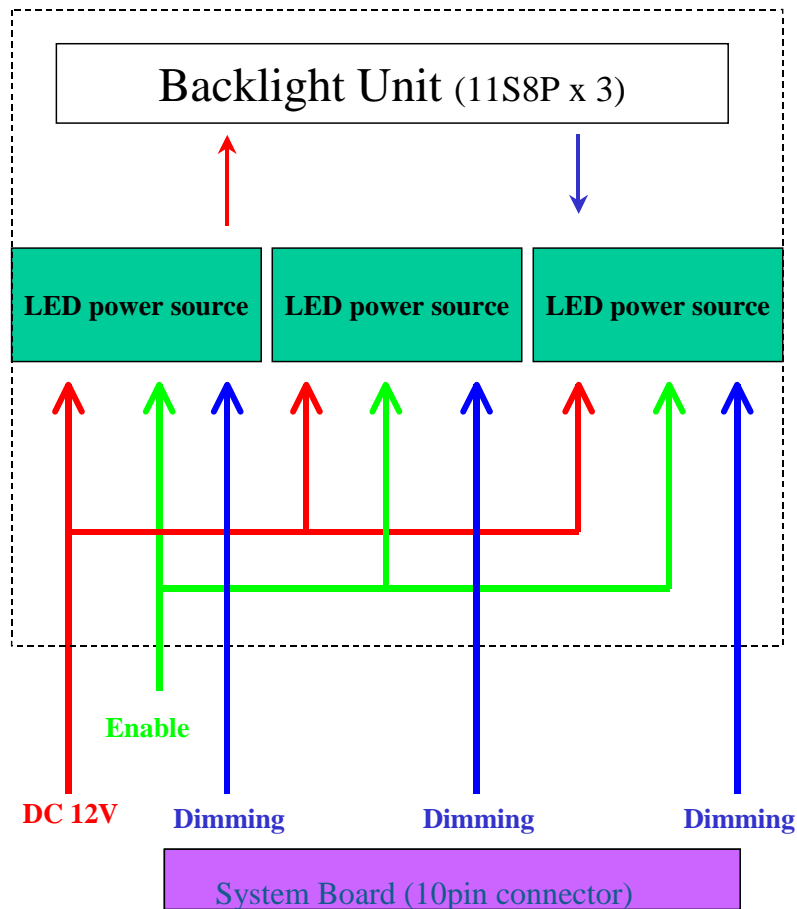

4. BLOCK DIAGRAM

4.1 TFT LCD MODULE

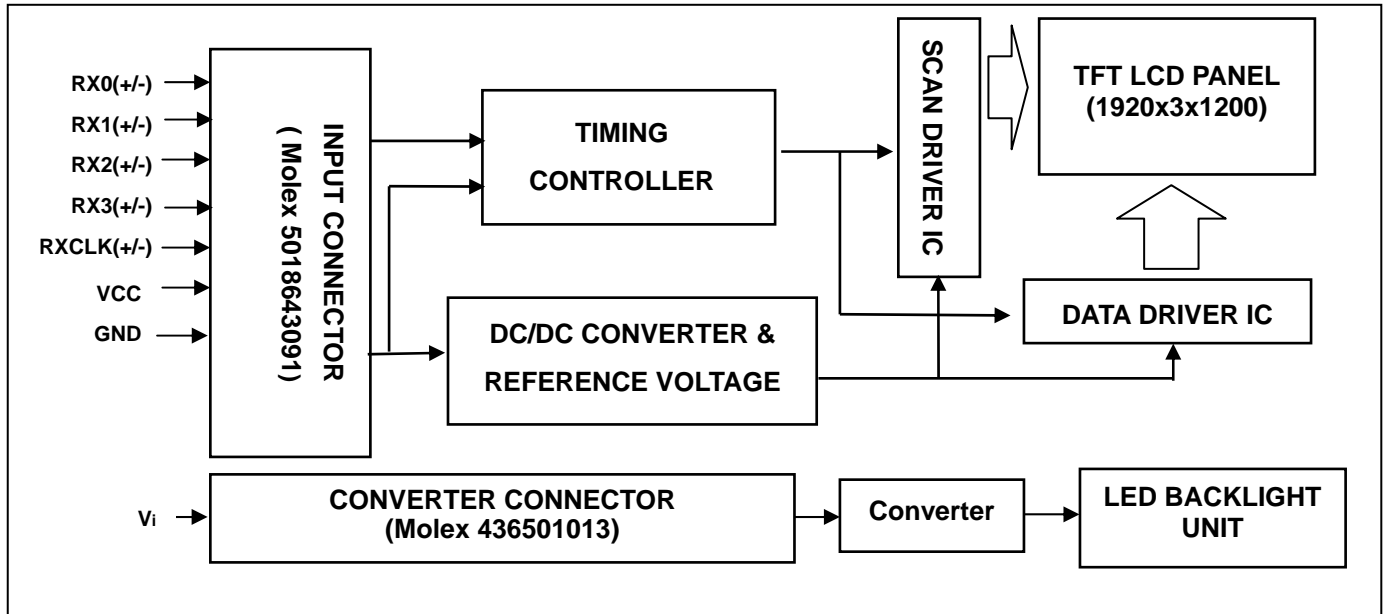

5. INTERFACE PIN ASSIGNMENT

5.1 TFT LCD MODULE

Pin No.	Symbol	Description	Note
1	RX00-	-LVDS differential data input, Chan 0-Odd	-
2	RX00+	+LVDS differential data input, Chan 0-Odd	-
3	RX01-	-LVDS differential data input, Chan 1-Odd	-
4	RX01+	+LVDS differential data input, Chan 1-Odd	-
5	RX02-	-LVDS differential data input, Chan 2-Odd	-
6	RX02+	+LVDS differential data input, Chan 2-Odd	-
7	VSS	Ground	
8	RXOC-	-LVDS differential Clock input (Odd)	
9	RXOC+	+LVDS differential Clock input (Odd)	
10	RX03-	-LVDS differential data input, Chan 3-Odd	
11	RX03+	+LVDS differential data input, Chan 3-Odd	
12	RXE0-	-LVDS differential data input, Chan 0-Even	-
13	RXE0+	+LVDS differential data input, Chan 0-Even	-
14	VSS	Ground	-
15	RXE1-	-LVDS differential data input, Chan 1-Even	-
16	RXE1+	+LVDS differential data input, Chan 1-Even	-
17	VSS	Ground	-
18	RXE2-	-LVDS differential data input, Chan 2-Even	-
19	RXE2+	+LVDS differential data input, Chan 2-Even	-
20	RXEC-	-LVDS differential Clock input (Even)	-
21	RXEC+	+LVDS differential Clock input (Even)	-
22	RXE3-	-LVDS differential data input, Chan 3-Even	-
23	RXE3+	+LVDS differential data input, Chan 3-Even	-
24	VSS	Ground	-
25	VSS	Ground	-
26	NC	No Connection	-
27	AGMODE	Aging mode selection [Default connection GND]	-
28	Vcc	+5.0V power supply	-
29	Vcc	+5.0V power supply	-
30	Vcc	+5.0V power supply	

Note (1) Connector Part No.: MOLEX (5018643091)

5.2 BACKLIGHT UNIT (Converter connector pin)

Pin	Symbol	Description	Remark
1	ADJ3	Area3 adjust	PWM Dimming
2	ADJ2	Area2 adjust	PWM Dimming
3	ADJ1	Area1 adjust	PWM Dimming
4	EN	Enable pin	3.3V
5	V _{GND}	Converter ground	Ground
6	V _{GND}	Converter ground	Ground
7	V _{GND}	Converter ground	Ground
8	V _i	Converter input voltage	12V
9	V _i	Converter input voltage	12V
10	V _i	Converter input voltage	12V

Note (1) Connector Part No.: MOLEX (436501013)

5.3 COLOR DATA INPUT ASSIGNMENT

The brightness of each primary color (red, green and blue) is based on the 8-bit gray scale data input for the color. The higher the binary input, the brighter the color. The table below provides the assignment of color versus data input.

Color		Data Signal																							
		Red								Green								Blue							
		R7	R6	R5	R4	R3	R2	R1	R0	G7	G6	G5	G4	G3	G2	G1	G0	B7	B6	B5	B4	B3	B2	B1	B0
Basic Colors	Black	0	0	0	0	0	0	0	0	0	0	0	0	0	0	0	0	0	0	0	0	0	0	0	
	Red	1	1	1	1	1	1	1	1	0	0	0	0	0	0	0	0	0	0	0	0	0	0	0	
	Green	0	0	0	0	0	0	0	0	1	1	1	1	1	1	1	1	0	0	0	0	0	0	0	
	Blue	0	0	0	0	0	0	0	0	0	0	0	0	0	0	0	0	1	1	1	1	1	1	1	
	Cyan	0	0	0	0	0	0	0	0	1	1	1	1	1	1	1	1	1	1	1	1	1	1	1	
	Magenta	1	1	1	1	1	1	1	1	0	0	0	0	0	0	0	0	1	1	1	1	1	1	1	
	Yellow	1	1	1	1	1	1	1	1	1	1	1	1	1	1	1	1	0	0	0	0	0	0	0	
	White	1	1	1	1	1	1	1	1	1	1	1	1	1	1	1	1	1	1	1	1	1	1	1	
Gray Scale Of Red	Red(0) / Dark	0	0	0	0	0	0	0	0	0	0	0	0	0	0	0	0	0	0	0	0	0	0		
	Red(1)	0	0	0	0	0	0	0	1	0	0	0	0	0	0	0	0	0	0	0	0	0	0		
	Red(2)	0	0	0	0	0	0	1	0	0	0	0	0	0	0	0	0	0	0	0	0	0	0		
	:	:	:	:	:	:	:	:	:	:	:	:	:	:	:	:	:	:	:	:	:	:	:		
	:	:	:	:	:	:	:	:	:	:	:	:	:	:	:	:	:	:	:	:	:	:	:		
	Red(253)	1	1	1	1	1	1	0	1	0	0	0	0	0	0	0	0	0	0	0	0	0	0		
	Red(254)	1	1	1	1	1	1	1	0	0	0	0	0	0	0	0	0	0	0	0	0	0	0		
	Red(255)	1	1	1	1	1	1	1	1	0	0	0	0	0	0	0	0	0	0	0	0	0	0		
Gray Scale Of Green	Green(0) / Dark	0	0	0	0	0	0	0	0	0	0	0	0	0	0	0	0	0	0	0	0	0	0		
	Green(1)	0	0	0	0	0	0	0	0	0	0	0	0	0	0	1	0	0	0	0	0	0	0		
	Green(2)	0	0	0	0	0	0	0	0	0	0	0	0	0	1	0	0	0	0	0	0	0	0		
	:	:	:	:	:	:	:	:	:	:	:	:	:	:	:	:	:	:	:	:	:	:	:		
	:	:	:	:	:	:	:	:	:	:	:	:	:	:	:	:	:	:	:	:	:	:	:		
	Green(253)	0	0	0	0	0	0	0	0	1	1	1	1	1	1	0	1	0	0	0	0	0	0		
	Green(254)	0	0	0	0	0	0	0	0	1	1	1	1	1	1	1	0	0	0	0	0	0	0		
	Green(255)	0	0	0	0	0	0	0	0	1	1	1	1	1	1	1	1	0	0	0	0	0	0		
Gray Scale Of Blue	Blue(0) / Dark	0	0	0	0	0	0	0	0	0	0	0	0	0	0	0	0	0	0	0	0	0	0		
	Blue(1)	0	0	0	0	0	0	0	0	0	0	0	0	0	0	0	0	0	0	0	0	0	1		
	Blue(2)	0	0	0	0	0	0	0	0	0	0	0	0	0	0	0	0	0	0	0	0	0	1		
	:	:	:	:	:	:	:	:	:	:	:	:	:	:	:	:	:	:	:	:	:	:	:		
	:	:	:	:	:	:	:	:	:	:	:	:	:	:	:	:	:	:	:	:	:	:	:		
	Blue(253)	0	0	0	0	0	0	0	0	0	0	0	0	0	0	0	1	1	1	1	1	1	0		
	Blue(254)	0	0	0	0	0	0	0	0	0	0	0	0	0	0	0	1	1	1	1	1	1	0		
	Blue(255)	0	0	0	0	0	0	0	0	0	0	0	0	0	0	0	1	1	1	1	1	1	1		

Note (1) 0: Low Level Voltage, 1: High Level Voltage

6. INTERFACE TIMING

6.1 INPUT SIGNAL TIMING SPECIFICATIONS

The input signal timing specifications are shown as the following table and timing diagram.

Signal	Item	Symbol	Min.	Typ.	Max.	Unit	Note
DCLK	Frequency	Fc	-	(154.13)	(159.26)	MHz	
Vertical Active Display Term	Total	Tv	(1202)	(1235)	(1235)	Th	Tv=Tvd+Tvb
	Display	Tvd	(1200)	(1200)	(1200)	Th	-
	Blank	Tvb	(2)	(35)	(35)	Th	-
Horizontal Active Display Term	Total	Th	(2000)	(2080)	(2080)	Tc	Th=Thd+Thb
	Display	Thd	(1920)	(1920)	(1920)	Tc	-
	Blank	Thb	(80)	(160)	(160)	Tc	-

Note (1) Since this assembly is operated in DE only mode, Hsync and Vsync input signals should be set to low logic level. Otherwise, this assembly would operate abnormally.

(2) Frame rate is 60Hz

INPUT SIGNAL TIMING DIAGRAM

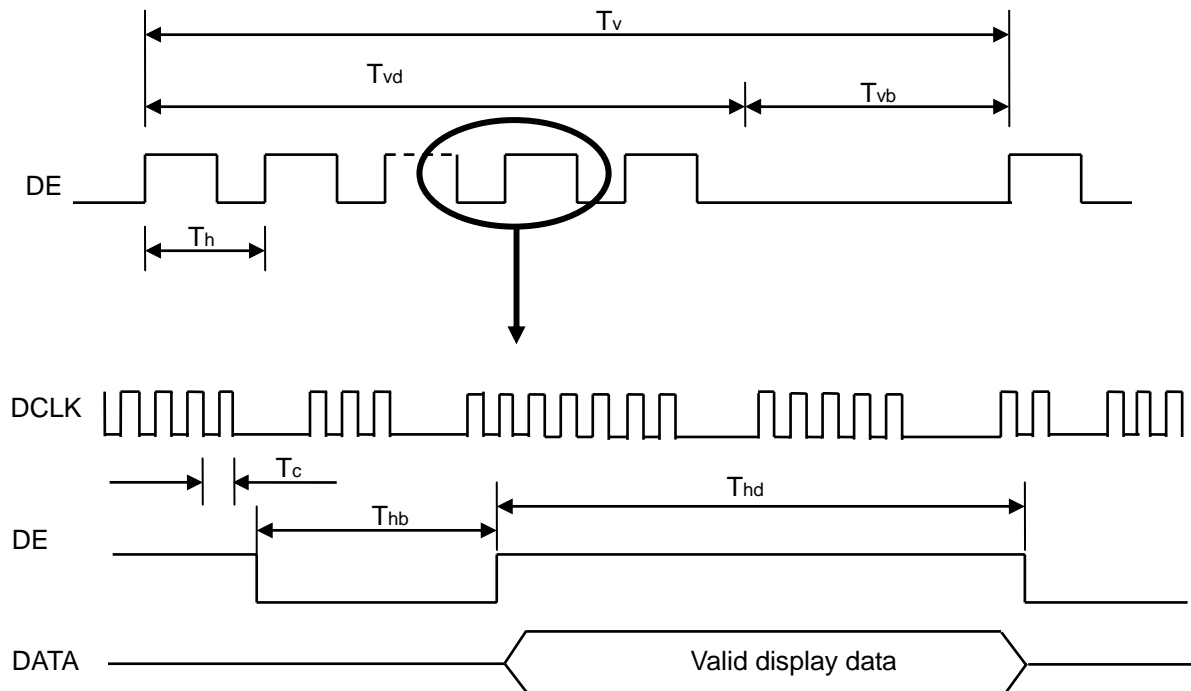

6.2 POWER ON/OFF SEQUENCE

To prevent a latch-up or DC operation of LCD assembly, the power on/off sequence should be as the diagram below.

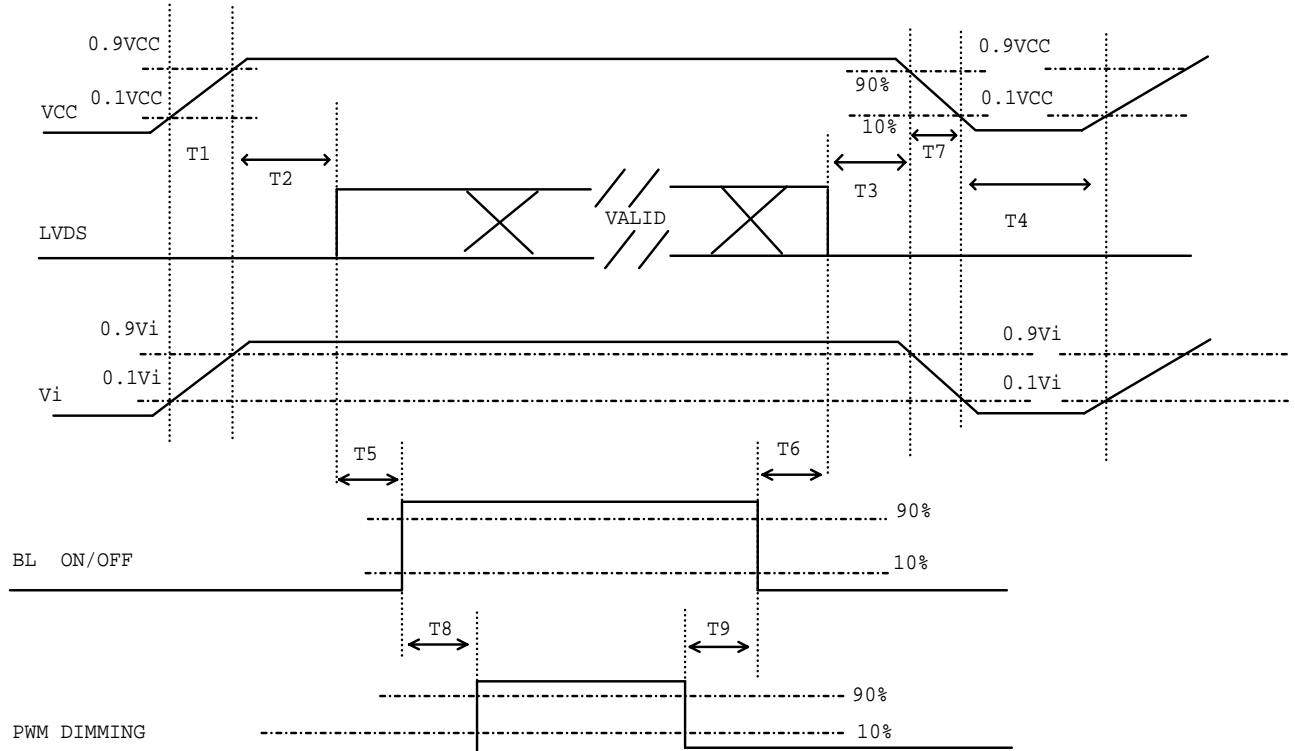

Power ON/OFF sequence

Note (1) Please avoid floating state of interface signal at invalid period.

Note (2) When the interface signal is invalid, be sure to pull down the power supply of LCD VCC to 0 V.

Note (3) The Backlight converter power must be turned on after the power supply for the logic and the interface signal is valid. The Backlight converter power must be turned off before the power supply for the logic and the interface signal is invalid.

Parameter	Value			Units
	Min	Typ	Max	
T1	0.5	-	10	ms
T2	0	-	50	ms
T3	0	-	50	ms
T4	500	-	-	ms
T5	200	-	-	ms
T6	200	-	-	ms
T7	5	-	100	ms
T8	10	-	-	ms
T9	10	-	-	Ms

6.3 The Input Data Format

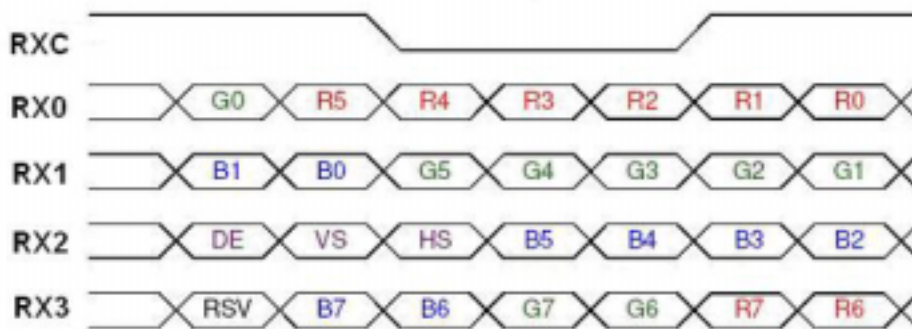

Note (1) R/G/B data 7: MSB, R/G/B data 0: LSB

Note (2) Please follow PSWG

Signal Name	Description	Remark
R7	Red Data 7 (MSB)	Red-pixel Data Each red pixel's brightness data consists of these 8 bits pixel data.
R6	Red Data 6	
R5	Red Data 5	
R4	Red Data 4	
R3	Red Data 3	
R2	Red Data 2	
R1	Red Data 1	
R0	Red Data 0 (LSB)	
G7	Green Data 7 (MSB)	Green-pixel Data Each green pixel's brightness data consists of these 8 bits pixel data.
G6	GreenData 6	
G5	GreenData 5	
G4	GreenData 4	
G3	GreenData 3	
G2	GreenData 2	
G1	GreenData 1	
G0	GreenData 0 (LSB)	
B7	Blue Data 7 (MSB)	Blue-pixel Data Each blue pixel's brightness data consists of these 8 bits pixel data.
B6	Blue Data 6	
B5	Blue Data 5	
B4	Blue Data 4	
B3	Blue Data 3	
B2	Blue Data 2	
B1	Blue Data 1	
B0	Blue Data 0 (LSB)	
RXCLKIN+ RXCLKIN-	LVDS Clock Input	
DE	Display Enable	
VS	Vertical Sync	
HS	Horizontal Sync	

Note (3) Output signals from any system shall be low or Hi-Z state when VCC is off

7. OPTICAL CHARACTERISTICS

7.1 TEST CONDITIONS

Item	Symbol	Value	Unit
Ambient Temperature	T _a	25±2	°C
Ambient Humidity	H _a	50±10	%RH
Supply Voltage	V _{CC}	5	V
Input Signal	According to typical value in "3. ELECTRICAL CHARACTERISTICS"		
Converter Current	I _L	20±1mA	mA

7.2 OPTICAL SPECIFICATIONS

The relative measurement methods of optical characteristics are shown in 7.2. The following items should be measured under the test conditions described in 7.1 and stable environment shown in Note (6).

Item		Symbol	Condition	Min.	Typ.	Max.	Unit	Note	
Contrast Ratio		CR	θ _x =0°, θ _y =0° Viewing angle at normal direction	(1500)	(2000)		-	(2)	
Response Time		T _R		-	(20)	(25)	ms	(3)	
		T _F		-	(9)	(15)	ms		
Center Luminance of White		L _C		(500)	(600)	-	cd/m ²	(4)	
White Variation		δW		-	(1.2)	(1.4)	-	(6)	
Chromaticity	Red	R _x		Typ. -0.05	Typ. +0.05	(0.629)		-	(5)
		R _y				(0.341)		-	
	Green	G _x				(0.316)		-	
		G _y				(0.622)		-	
	Blue	B _x				(0.148)		-	
		B _y	(0.070)			-			
	White	W _x	(0.313)			-			
		W _y	(0.329)			-			
Viewing Angle	Horizontal	θ _{x+}	(80)	(88)	-	Deg.	(1)		
		θ _{x-}	(80)	(88)	-				
	Vertical	θ _{y+}	(80)	(88)	-				
		θ _{y-}	(80)	(88)	-				

Note (1) Definition of Viewing Angle (θ_x, θ_y):

Viewing angles are measured by BM5A

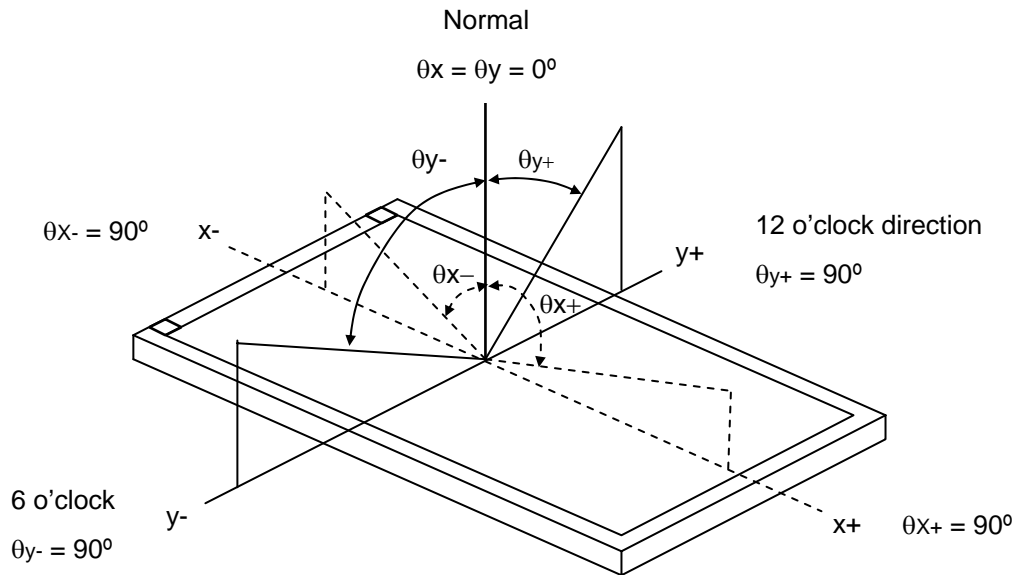

Note (2) Definition of Contrast Ratio (CR):

The contrast ratio can be calculated by the following expression.

$$\text{Contrast Ratio (CR)} = L_{255} / L_0$$

L255: Luminance of gray level 255

L 0: Luminance of gray level 0

CR = CR (5), where CR (X) is corresponding to the Contrast Ratio of the point X at the figure in Note (7).

Note (3) Definition of Response Time (T_R, T_F):

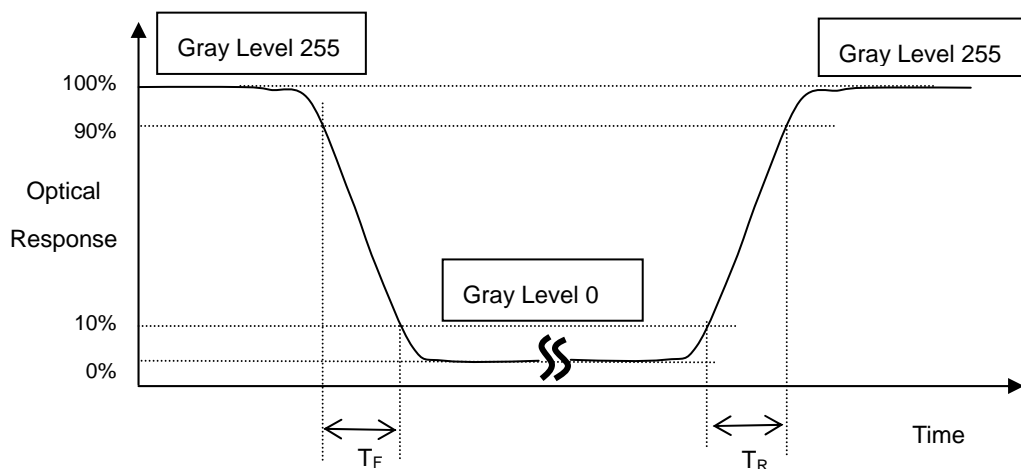

Note (4) Definition of Luminance of White (L_C):

Measure the luminance of gray level 255 at center point and 5 points

$L_C = L(5)$, where $L(X)$ is corresponding to the luminance of the point X at the figure in Note (7).

Note (5) Measurement Setup:

The LCD assembly should be stabilized at given temperature for 30 minutes to avoid abrupt temperature change during measuring. In order to stabilize the luminance, the measurement should be executed after lighting Backlight for 30 minutes in a windless room.

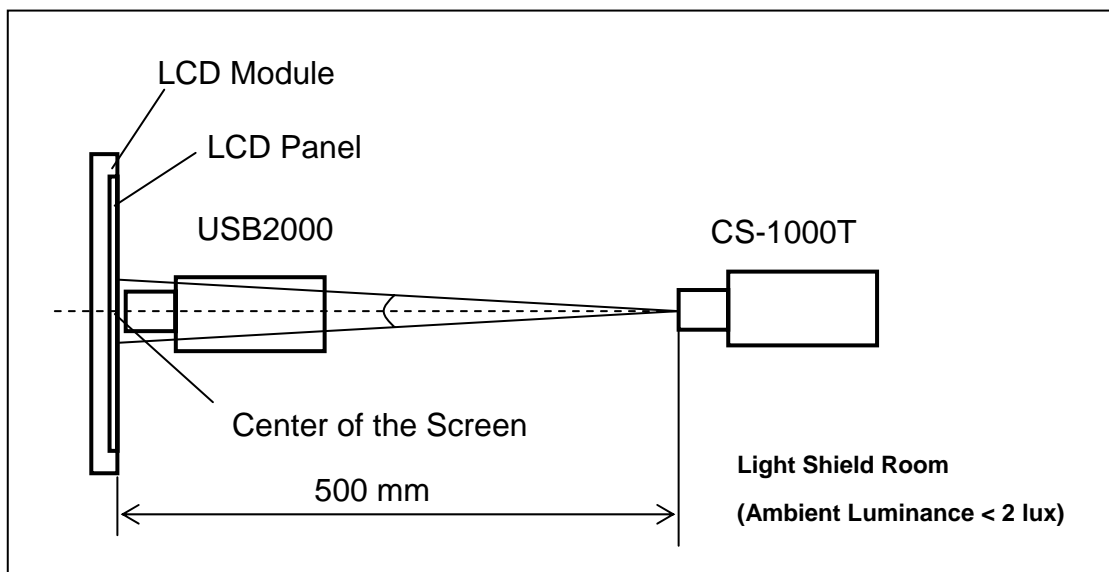

Note (6) Definition of White Variation (δW):

Measure the luminance of gray level 255 at 5 points

$$\delta W = \text{Maximum } [L(1), L(2), L(3), L(4), L(5)] / \text{Minimum } [L(1), L(2), L(3), L(4), L(5)]$$

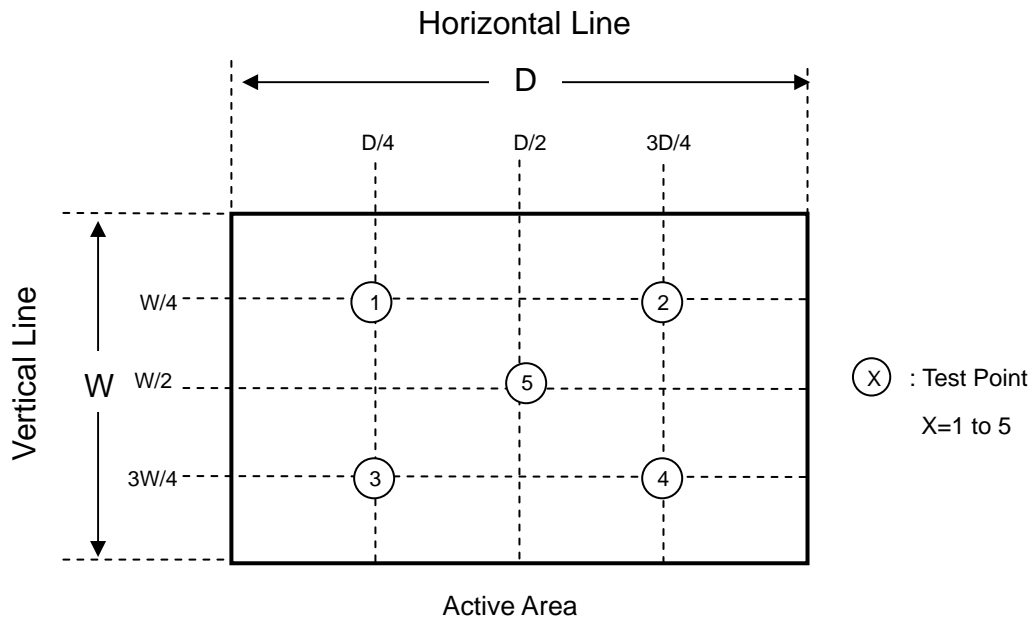

8. Reliability Test Criteria

Test Item	Test Condition	Note
High Temperature Storage Test	90°C, 500 hours	(1) (2)
Low Temperature Storage Test	-40°C, 500 hours	
Thermal Shock Storage Test	-40°C, 0.5hour 85 , 0.5hour; 250cycles, 1hour/cycle	
High Temperature Operation Test	80°C, 600 hours	
Low Temperature Operation Test	-30°C, 120 hours	
High Temperature & High Humidity Operation Test	60°C, 90%RH, 500 hours	
Shock (Non-Operating)	100G, 11ms, half sine wave, 3 time for $\pm X$, $\pm Y$, $\pm Z$.	
Vibration (Non-Operating)	2.9Grms, 10 ~ 2000 Hz, 17 hour/cycle, 3 cycles each X, Y, Z	(3)

Note (1) There should be no condensation on the surface of panel during test.

Note (2) Temperature of panel display surface area should be 80 °C Max.

Note (3) At testing Vibration and Shock, the fixture in holding the module has to be hard and rigid enough so that the module would not be twisted or bent by the fixture.

Note (4) In the standard conditions, there is no function failure issue occurred. All the cosmetic specification is judged before the reliability test.

9. PACKAGING

9.1 PACKING SPECIFICATIONS

- (1) 8pcs LCD modules / 1 Box
- (2) Box dimensions: 570 (L) X 450 (W) X 320 (H) mm
- (3) Weight: approximately 22.1Kg (8 modules per box)

9.2 PACKING METHOD

- (1) Carton Packing should have no failure in the following reliability test items.

Test Item	Test Conditions	Note
Vibration	ISTA STANDARD Random, Frequency Range: 2 – 200 Hz Top & Bottom: 30 minutes (+Z), 10 min (-Z), Right & Left: 10 minutes (X) Back & Forth 10 minutes (Y)	Non Operation
Dropping Test	1 Angle, 3 Edge, 6 Face, 46 cm	Non Operation

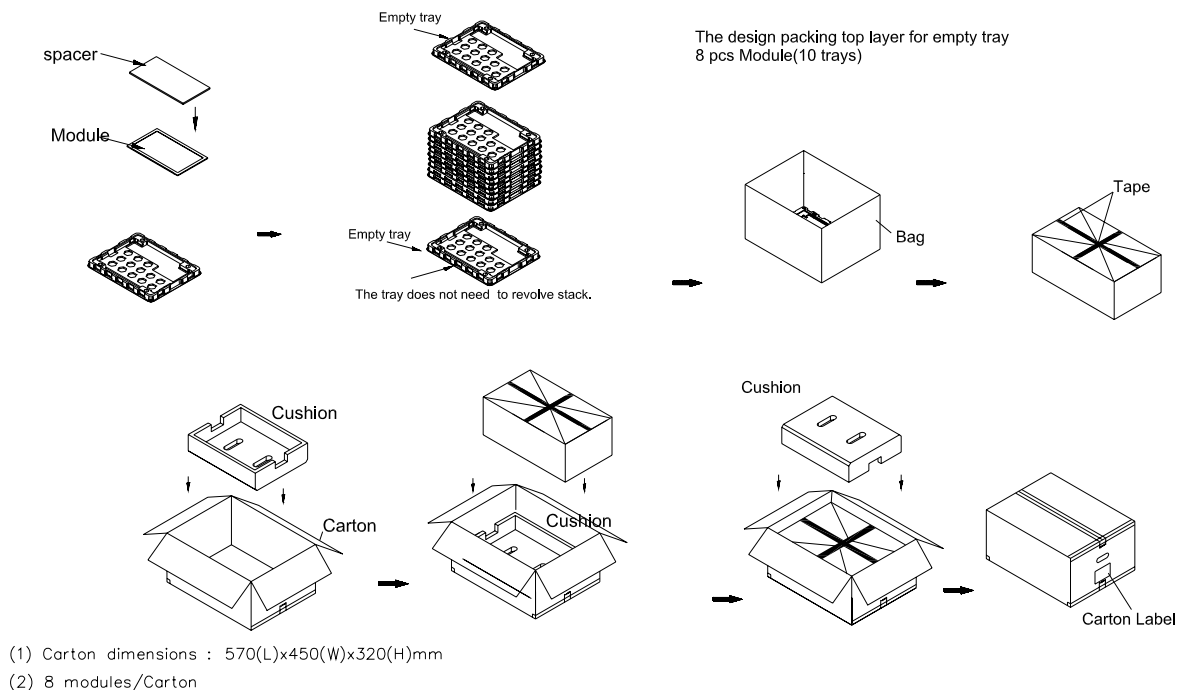

Figure. 9-1 Packing method

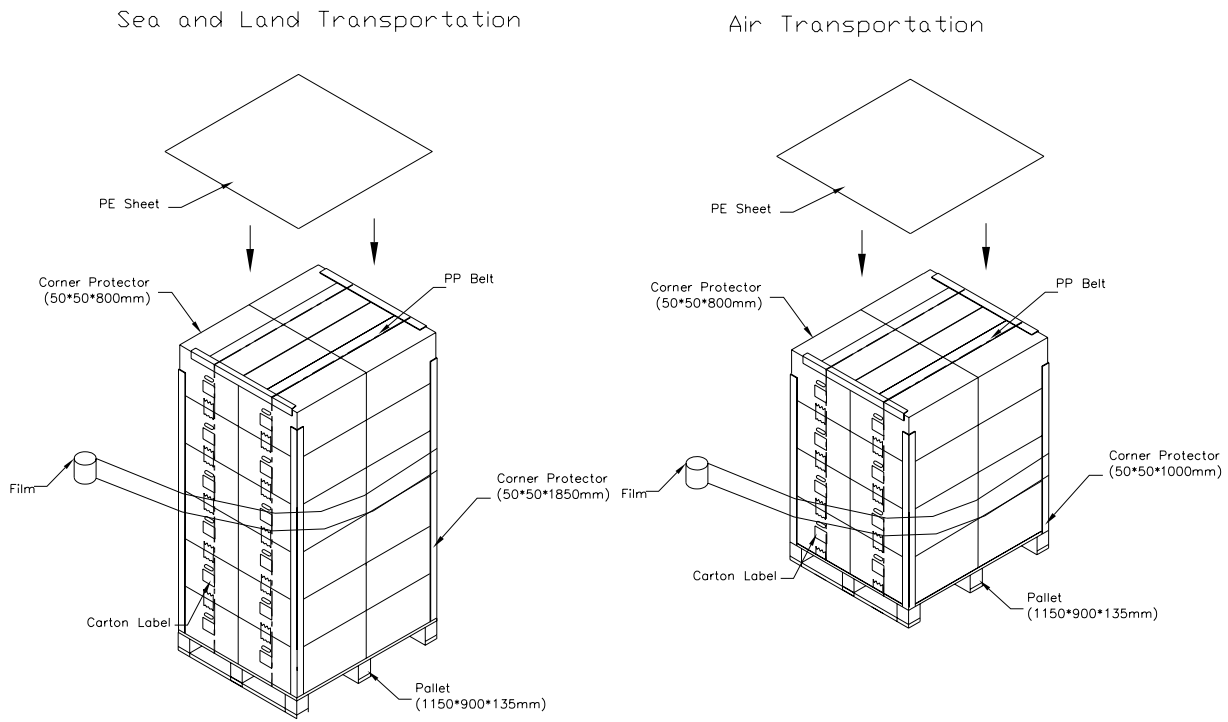
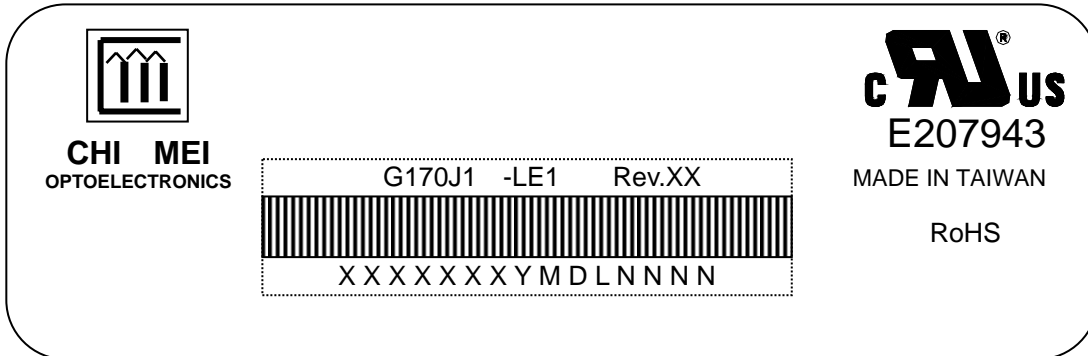

Figure. 9-2 Packing method

10. DEFINITION OF LABELS

10.1 CMI MODULE LABEL

The barcode nameplate is pasted on each module as illustration, and its definitions are as following explanation.



- (a) Model Name: G170J1-LE1
- (b) Revision: Rev. XX, for example: A0, A1... B1, B2... or C1, C2...etc.
- (c) Serial ID: XXXXXYYMDLNNNN

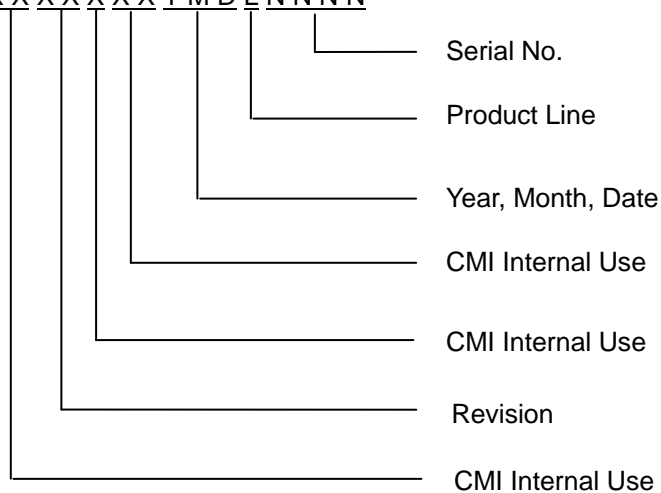

Serial ID includes the information as below:

- (a) Manufactured Date: Year: 0~9, for 2000~2009
 Month: 1~9, A~C, for Jan. ~ Dec.
 Day: 1~9, A~Y, for 1st to 31st, exclude I ,O, and U.
- (b) Revision Code: Cover all the change
- (c) Serial No.: Manufacturing sequence of product
- (d) Product Line: 1 -> Line1, 2 -> Line 2, ...etc.

11. PRECAUTIONS

11.1 ASSEMBLY AND HANDLING PRECAUTIONS

- (1) Do not apply rough force such as bending or twisting to the module during assembly.
- (2) It is recommended to assemble or to install a module into the user's system in clean working areas. The dust and oil may cause electrical short or worsen the polarizer.
- (3) Do not apply pressure or impulse to the module to prevent the damage of LCD panel and Backlight.
- (4) Always follow the correct power-on sequence when the LCD module is turned on. This can prevent the damage and latch-up of the CMOS LSI chips.
- (5) Do not plug in or pull out the I/F connector while the module is in operation.
- (6) Do not disassemble the module.
- (7) Use a soft dry cloth without chemicals for cleaning, because the surface of polarizer is very soft and easily scratched.
- (8) Moisture can easily penetrate into LCD module and may cause the damage during operation.
- (9) High temperature or humidity may deteriorate the performance of LCD module. Please store LCD modules in the specified storage conditions.
- (10) When ambient temperature is lower than 10°C, the display quality might be reduced. For example, the response time will become slow, and the starting voltage of backlight will be higher than that of room temperature.
- (11) Do not keep same pattern in a long period of time. It may cause image sticking on LCD.

11.2 SAFETY PRECAUTIONS

- (1) If the liquid crystal material leaks from the panel, it should be kept away from the eyes or mouth. In case of contact with hands, skin or clothes, it has to be washed away thoroughly with soap.
- (2) After the module's end of life, it is not harmful in case of normal operation and storage.

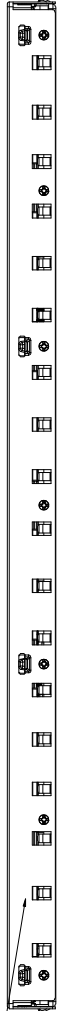

Data CDF Position
(SI mechanical structure should not touch the positions of Data CDF)

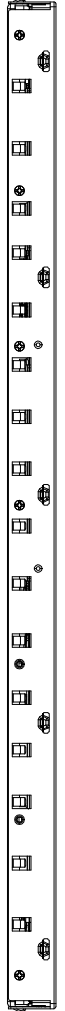
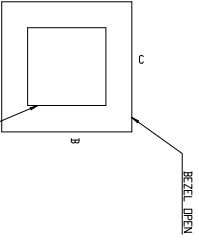
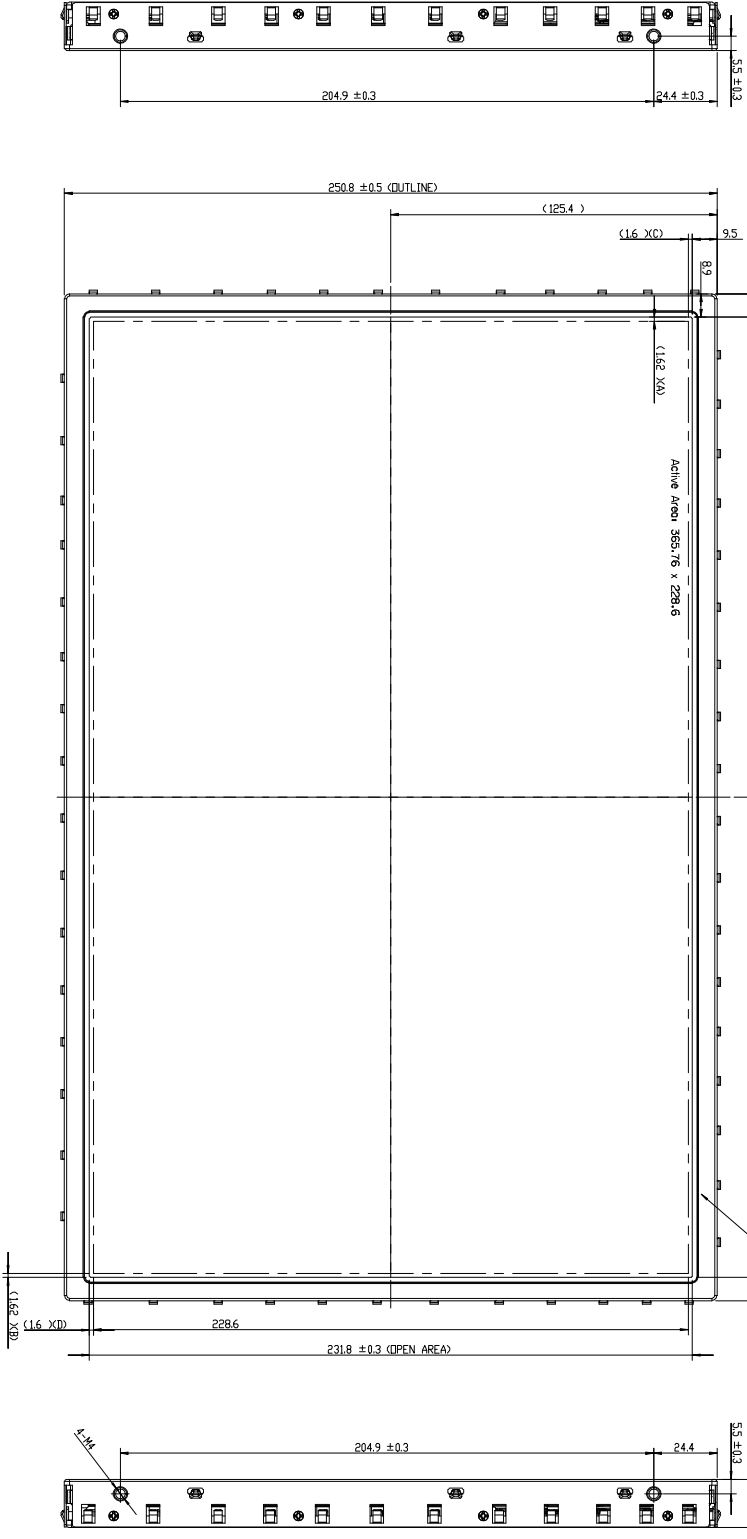

Mark	Description	Date	Changed By	Approved By	EON No.	Remark
A	Modify cat line	22-APR-2011	CGRINA	SV	EP002347	
A	CHINA CONNECTOR TYPE	21-DEC-2010	CGRINA	SV		

NOTES:
 A UNSPECIFIED TOLERANCE=±0.5mm
 A 21/7 CONNECTOR SPEC NILEX (G01864991)/CNL NDC2-0057319
 A 21/7 CONNECTOR SPEC NILEX (G01864991)/CNL NDC2-0057319
 A 2 SIDE MOUNT HELI THROLE (S107507) (QMLA)
 S107507 ANY POSITION TOLERANCE=±0.5mm & L-DK=1mm

General	Tolerance	Unless Spec	Surface	Finish	Material	Part No.	Quantity	Scale	Sheet	Total
0-6	±0.1	300-600	±0.3	±0.6					3 of 1	1 of 1
6-30	±0.15	600-	±0.6							
30-300	±0.2	FINANCE	±1.0*							

TITLE: NSI MODULE CONTROLLER			
Approved By	Design No.	Contract No.	REV. C
Checked	Drawn	Part No.	
Designer	CONDA	DATE (22-APR-2011)	
		Scale	
		Sheet	
		Total	

ALL RIGHTS RESERVED. COMPANY PROPRIETARY

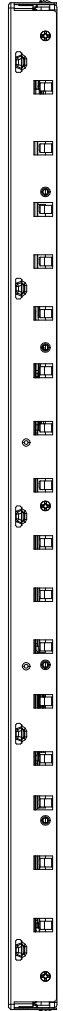
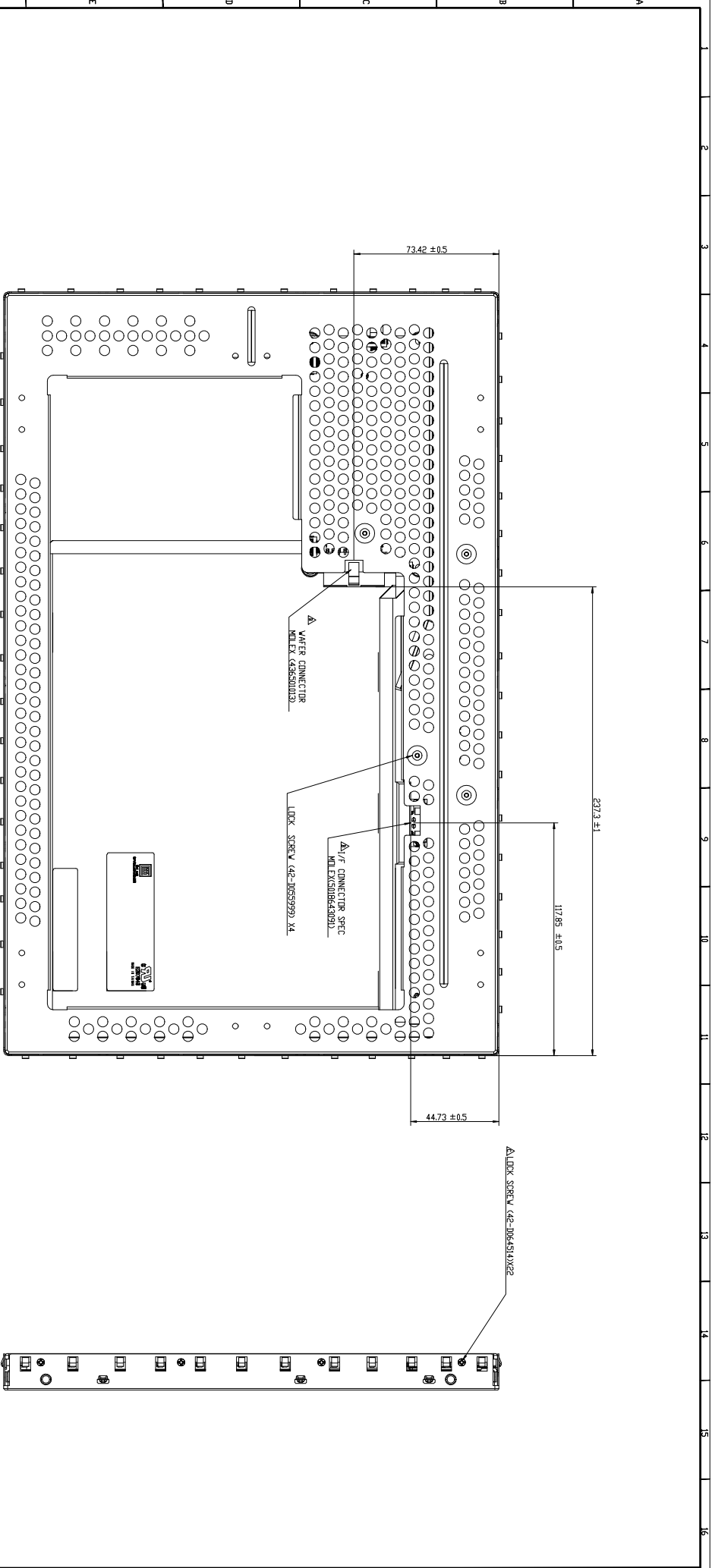

NOTES:
 A UNSPECIFIED TOLERANCE=0.2mm.
 A 21/F CONNECTOR SPEC MHLX30843091/CMT NO.25-2057319
 A 4SIDE MOUNT HOLE DOUBLE SCREW CH. (M4X2)
 S.SCREW TORQUE: 0.4gf-cm

Mark	Description	Date	Changes By	Approved By	EON No.	Remark
Δ	Modify out line	22-APR-2011	COBINA	SV	EP003447	
Δ	Change connector type	21-DEC-2010	COBINA	SV		

TITLE		REV.	
MSY MOBILE COMPLET		C	
Approved by	Design No.	CONTINUED	
Checked	Part No.		
Drawn	Material		
Design	Date	22-APR-2011	Scale
CHINESE MANUFACTURE		ALL RIGHTS RESERVED. COMPANY PROPRIETARY	

General	Tolerance	Unless Specified
CS	±0.05	±0.05
CS	±0.05	±0.05
CS	±0.05	±0.05

1 2 3 4 5 6 7 8 9 10 11 12 13 14 15 16