

# HITACHI

KAOHSIUNG HITACHI  
ELECTRONICS CO.,LTD  
P.O. BOX 26-27  
2,13TH EAST ST. K.E.P.Z.  
KAOHSIUNG TAIWAN R.O.C.  
TEL:(07) 821-5811(7 LINE)  
FAX:(07) 821-5815

FOR MESSRS: \_\_\_\_\_

DATE: Jun.15,2007

## SP14Q006-TZA CONTENTS

No.	ITEM	SHEET No.	PAGE
1	COVER	7B64PS 2701- SP14Q006-TZA-5	1-1/1
2	RECORD OF REVISION	7B64PS 2702- SP14Q006-TZA-5	2-1/2~2/2
3	GENERAL SPECIFICATION	7B64PS 2703- SP14Q006-TZA-5	3-1/1
4	ABSOLUTE MAXIMUM RATINGS	7B64PS 2704- SP14Q006-TZA-5	4-1/1
5	ELECTRICAL CHARACTERISTICS	7B64PS 2705- SP14Q006-TZA-5	5-1/2~2/2
6	OPTICAL CHARACTERISTICS	7B64PS 2706- SP14Q006-TZA-5	6-1/3~3/3
7	BLOCK DIAGRAM	7B64PS 2707- SP14Q006-TZA-5	7-1/1
8	INTERFACE TIMING CHART	7B64PS 2708- SP14Q006-TZA-5	8-1/3~3/3
9	OUTLINE DIMENSIONS	7B63PS 2709- SP14Q006-TZA-5 7B64PS 2709- SP14Q006-TZA-5	9-1/2 9-2/2
10	APPEARANCE STANDARD	7B64PS 2710- SP14Q006-TZA-5	10-1/3~3/3
11	PRECAUTION IN DESIGN	7B64PS 2711- SP14Q006-TZA-5	11-1/2~2/2
12	DESIGNATION OF LOT MARK	7B64PS 2712- SP14Q006-TZA-5	12-1/1
13	PRECAUTION FOR USE	7B64PS 2713- SP14Q006-TZA-5	13-1/1
14	TOUCH PANEL SPECIFICATION	7B64PS 2714- SP14Q006-TZA-5	14-1/4~4/4

\* When products will be discontinued , customers will be informed by HITACHI with twelve months prior announcement.

ACCEPTED BY: \_\_\_\_\_

PROPOSED BY: Jan Cheng

KAOHSIUNG HITACHI ELECTRONICS CO.,LTD.	Sh. No.	7B64PS 2701- SP14Q006-TZA-5	PAGE	1-1/1
---	------------	-----------------------------	------	-------

## RECORD OF REVISION

DATE	SHEET No.	SUMMARY																				
Oct.22,'03	7B64PS2709- SP14Q006-TZA-2 Page 9-2/2	Changed LED I/F : JAK/1L-G-4S-S3C2 ↓ JAK/IL-G-4S-S3C2																				
Mar.31,'04	7B64PS2708- SP14Q006-TZA-3 Page 8-3/3	8.3 POWER ON/OFF TIMING SEQUENCE Revised tDLD min. 200 → 50 Revised tCH max. 200 → 30																				
Jun.04,'04	7B64PS 2705- SP14Q006-TZA-4 Page 5-1/2	5.1 ELECTRICAL CHARACTERISTICS Added																				
		<table border="1" style="width: 100%; border-collapse: collapse;"> <thead> <tr> <th>ITEM</th> <th>SYMBOL</th> <th>MIN.</th> <th>TYP.</th> <th>MAX</th> </tr> </thead> <tbody> <tr> <td>Power Supply Voltage Logic</td> <td>VDD-VSS</td> <td>3.2</td> <td>3.3</td> <td>3.4</td> </tr> <tr> <td rowspan="3">Recommend LC Driving Voltage</td> <td rowspan="3">VDD-V0</td> <td>21.0</td> <td>22.0</td> <td>23.0</td> </tr> <tr> <td>20.0</td> <td>21.0</td> <td>22.0</td> </tr> <tr> <td>19.0</td> <td>20.0</td> <td>21.0</td> </tr> </tbody> </table>	ITEM	SYMBOL	MIN.	TYP.	MAX	Power Supply Voltage Logic	VDD-VSS	3.2	3.3	3.4	Recommend LC Driving Voltage	VDD-V0	21.0	22.0	23.0	20.0	21.0	22.0	19.0	20.0
	ITEM	SYMBOL	MIN.	TYP.	MAX																	
	Power Supply Voltage Logic	VDD-VSS	3.2	3.3	3.4																	
	Recommend LC Driving Voltage	VDD-V0	21.0	22.0	23.0																	
20.0			21.0	22.0																		
19.0			20.0	21.0																		
7B64PS 2706- SP14Q006-TZA-4 Page 6-3/3	6.2 OPTICAL CHARACTERISTICS OF BACKLIGHT Added The LCD driving voltage should be adjusted at the voltage where the peak contrast is obtained.																					
7B64PS 2710- SP14Q006-TZA-4 Page 10-1/3	10.1 APPEARANCE INSPECTION CONDITION Revised 45°→25°																					
7B64PS2711 SP14Q006-TZA-4 Page 14-1/4	14.1.2 OPERATING CONDITIONS Revised Operating Voltage : 5VDC→5.0 /3.3 VDC																					
May.04,'07	7B64PS2703 SP14Q006-TZA-5 Page 3-1/1	3. GENERAL SPECIFICATIONS Added (11) Backlight Type LED(Color : white) ↓ (11) Backlight Type LED(Color : white) Life time : 40Kh @ 25°C Note : Life time for half of initial brightness																				
		7B64PS2705 SP14Q006-TZA-5 Page 5-2/2	5.2 ELECTRICAL CHARACTERISTICS OF LED BACKLIGHT Revised  <div style="display: flex; justify-content: space-around; align-items: flex-end;"> <div style="text-align: center;"> <p>ALLOWABLE FORWARD CURRENT (mA / pcs)</p> <p>AMBIENT TEMPERATURE(°C)</p> </div> <div style="text-align: center;"> <p>allowable forward current (mA/pcs)</p> <p>Ambient Temperature(°C)</p> </div> </div>																			

## RECORD OF REVISION

DATE	SHEET No.	SUMMARY
May.04,'07	7B64PS2712 SP14Q006-TZA-5 Page 12-1/1	12. DESIGNATION OF LOT MARK Added REVISION A

### 3. GENERAL SPECIFICATIONS

- (1) Part Name SP14Q006-TZA
- (2) Outer Dimensions 167.0(W)mm×109.0(H)mm×11.4(D) mm max.
- (3) Effective Area 120(W)mm min. × 89(H)mm min.
- (4) Dot Size 0.345(W)min. × 0.345(H)min.
- (5) Dot Pitch 0.360(W)mm × 0.360(H)mm
- (6) Dot Number (Resolution) 320 (W) × 240 (H) dots
- (7) Duty Ratio 1/240
- (8) LCD Type Transflective type F-B / W STN  
With glare type upper polarizer
- (9) Viewing Direction 6 O'clock
- (10) Viewing Angle Viewing Angle in Rear - Front  
(12:00) (6:00)  
R-F=90°(typ.)
- (11) Backlight Type LED(Color : white)  
Life time : 40Kh @ 25°C  
Note : Life time for half of initial brightness
- (12) Touch Panel Analog resistive  
Transparency : 76% min.  
Surface type : anti glare

## 4. ABSOLUTE MAXIMUM RATINGS

### 4.1 ELECTRICAL ABSOLUTE MAXIMUM RATINGS

VSS=0V : STANDARD

ITEM	SYMBOL	MIN.	MAX.	UNIT	COMMENT
Power Supply for Logic	VDD-VSS	0	6.0	V	
Power Supply for LC Driving	VDD-VEE	0	27.5	V	
Input Signal Voltage	$V_i$	-0.3	VDD+0.3	V	(Note 1)
Static Electricity	VESD0	-	±100	V	(Note 2,3,4)
	VESD1	-	±10	kV	(Note 2,3,5)

Note 1 :  $\overline{\text{DOFF}}$  , FLM , CL1 , CL2 , D0~D3.

Note 2: Make certain you are grounded when handling LCM.

Note 3 : Energy storage capacitance 200pF , discharge resistance 250Ω Ta=25°C , 60%RH.

Note 4 : Contact discharge to I/F connector pins.

Note 5 : Contact discharge to front metal bezel.

### 4.2 ENVIRONMENTAL ABSOLUTE MAXIMUM RATINGS

ITEM	OPERATING		STORAGE		COMMENT
	MIN.	MAX.	MIN.	MAX.	
Ambient Temperature	-20°C	70°C	-30°C	80°C	(Note 2,3,6,7)
Humidity	(Note 1)		(Note 1)		Without Condensation
Vibration	-	2.45m/s <sup>2</sup> (0.25G)	-	11.76m/s <sup>2</sup> (1.2G) (Note 5)	(Note 4) 1h max.
Shock	-	29.4m/s <sup>2</sup> (3 G)	-	490.0m/s <sup>2</sup> (50 G) (Note 5)	X · Y · Z Directions
Corrosive Gas	Not Acceptable		Not Acceptable		

Note 1 : Ta ≤ 40°C : 85%RH max.

Ta > 40°C : Absolute humidity must be lower than the humidity of 85%RH at 40°C

Note 2 : Ta at -30°C --- < 48h , at 80°C --- < 168h.

Note 3 : Background color changes slightly depending on ambient temperature.  
This phenomenon is reversible.

Note 4 : 5Hz~100Hz (Except resonance frequency)

Note 5 : This module should be operated normally after finish the test.

Note 6 : The response time will be slower under low temperature.

Note 7 : Operation temp not include touch panel.

KAOSIUNG HITACHI ELECTRONICS CO.,LTD.	DATE	Jun.15,'07	Sh. No.	7B64PS 2704- SP14Q006-TZA-5	PAGE	4-1/1
--	------	------------	------------	-----------------------------	------	-------

## 5. ELECTRICAL CHARACTERISTICS

### 5.1 ELECTRICAL CHARACTERISTICS

ITEM	SYMBOL	CONDITION	MIN.	TYP.	MAX.	UNIT	COMMENT
Power Supply Voltage for Logic	VDD-VSS	-	4.75	5.0	5.25	V	
			3.2	3.3	3.4		
Power Supply Voltage for LC Driving	VEE-VSS	-	-23.1	-22.0	-20.9	V	
Input Signal Voltage	Vi	H LEVEL	0.8VDD	-	VDD	V	(Note1)
		L LEVEL	0	-	0.2VDD	V	
Power Supply Current for Logic	IDD	VDD-VSS=5.0V VEE-VSS= -22.0V	-	6.0	-	mA	(Note2)
Power Supply Current for LC Driving	IEE	VDD-VSS=5.0V VEE-VSS= -22.0V	-	5.0	-	mA	(Note2)
Recommended LC Driving Voltage	VDD-V0	Ta= 0°C , $\phi = 0^\circ$	21.0	22.0	23.0	V	(Note3)
		Ta=25°C , $\phi = 0^\circ$	20.0	21.0	22.0	V	
		Ta=50°C , $\phi = 0^\circ$	19.0	20.0	21.0	V	
Frame Frequency	fFLM	-	70	75	80	Hz	(Note4)

Note 1 :  $\overline{\text{DOFF}}$  , FLM , CL1 , CL2 , D0~D3.

Note 2 : FLM=75Hz , test pattern is all "Q".  
VDD-V0=21.0V , Ta=25°C

Note 3 : Recommended LC driving voltage may fluctuate about  $\pm 1.0\text{V}$  by each module.  
Test pattern is all "Q"

Note 4 : Please set the frame frequency so as to avoid flicker and rippling on the display.

## 5.2 ELECTRICAL CHARACTERISTICS OF LED BACKLIGHT

ITEM	SYMBOL	CONDITION	MIN.	TYP.	MAX.	UNIT	COMMENT
Power Supply Voltage for LED	VLED	-	-	5.0	5.2	V	
Power Supply Current for LED	ILED	VLED=5.0V	-	160	-	mA	Note 1

Note 1 : The ILED changes depending on ambient temperature.

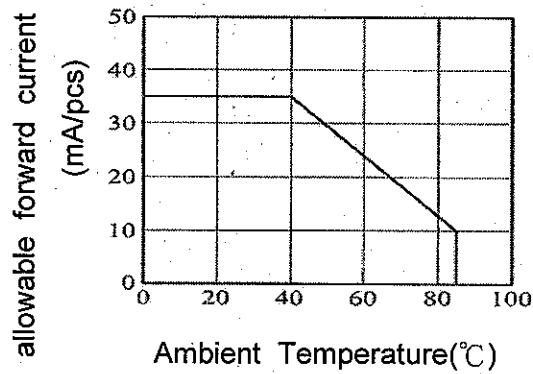

# 6. OPTICAL CHARACTERISTICS

6.1 OPTICAL CHARACTERISTICS Ta=25°C (Backlight OFF)

ITEM	SYMBOL	CONDITION	MIN.	TYP.	MAX.	UNIT	NOTE
Viewing Area	-	$K \geq 2.0 \theta = 0^\circ$ $\phi 1 + \phi 2$	-	90	-	deg.	1
	-	$K \geq 2.0 \theta = 90^\circ$ $\phi 1 + \phi 2$	-	80	-	deg.	1
Contrast Ratio	K	$\phi = 0^\circ, \theta = 0^\circ$	-	5	-	-	2,3
Response Time (Rise)	tr	$\phi = 0^\circ, \theta = 0^\circ$	-	(336)	-	ms	4
Response Time (Fall)	tf	$\phi = 0^\circ, \theta = 0^\circ$	-	(148)	-	ms	4

Note 1 : Definition of  $\theta$  and  $\phi$   
(Normal)  
Viewing direction

(Measure condition by Hitachi)

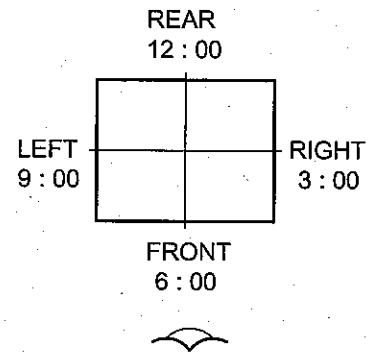
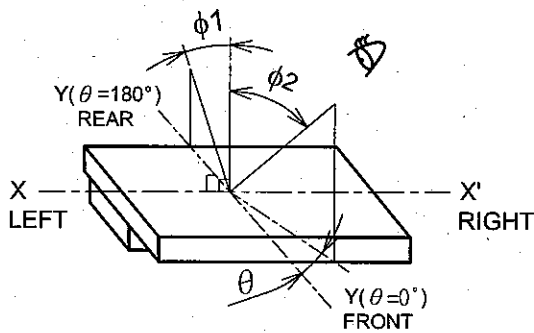

Note 2 : Definition of viewing angle  $\phi 1$  and  $\phi 2$

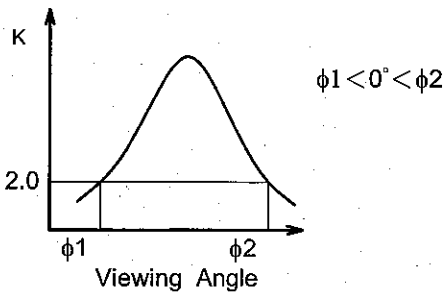

Contrast ratio K vs viewing angle  $\phi$

Note 3 : Definition of contrast "K"

$$K = \frac{\text{Brightness on non-selected dot (B1)}}{\text{Brightness on selected dot (B2)}}$$

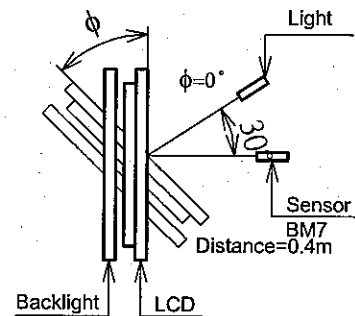
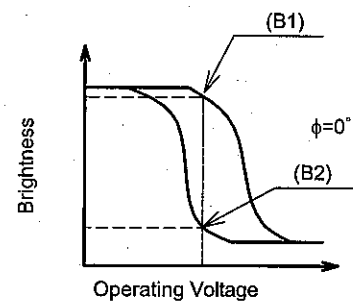



Note 4 : Definition of optical response

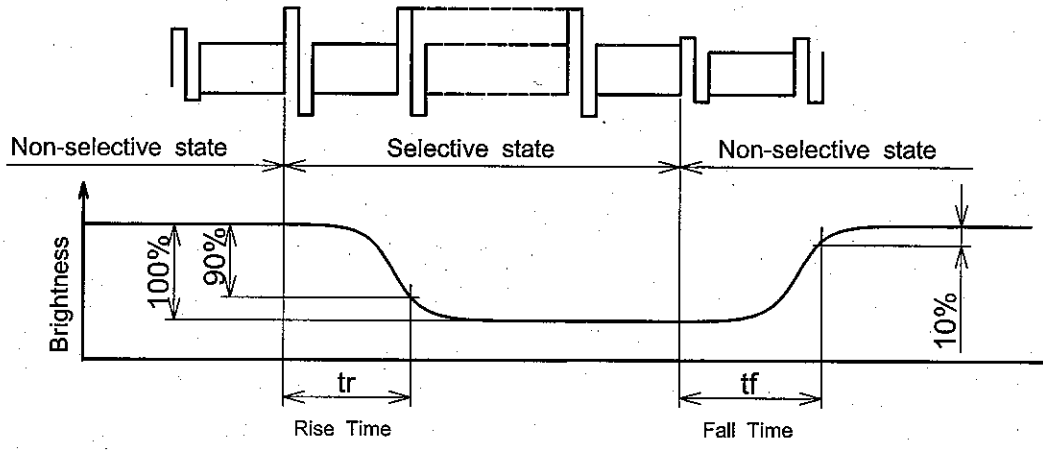

## 6.2 OPTICAL CHARACTERISTICS OF BACKLIGHT

(Backlight ON)

ITEM	MIN.	TYP.	MAX.	UNIT	NOTE
Brightness	-	40	-	cd/m <sup>2</sup>	ILED=160mA
Brightness Uniformity	-	-	±30	%	Note 1

Ta=25°C, Display data should be all "ON".

The LCD driving voltage should be adjusted at the voltage where the peak contrast is obtained.

Note 1 : Measure of the following 9 places on the display.

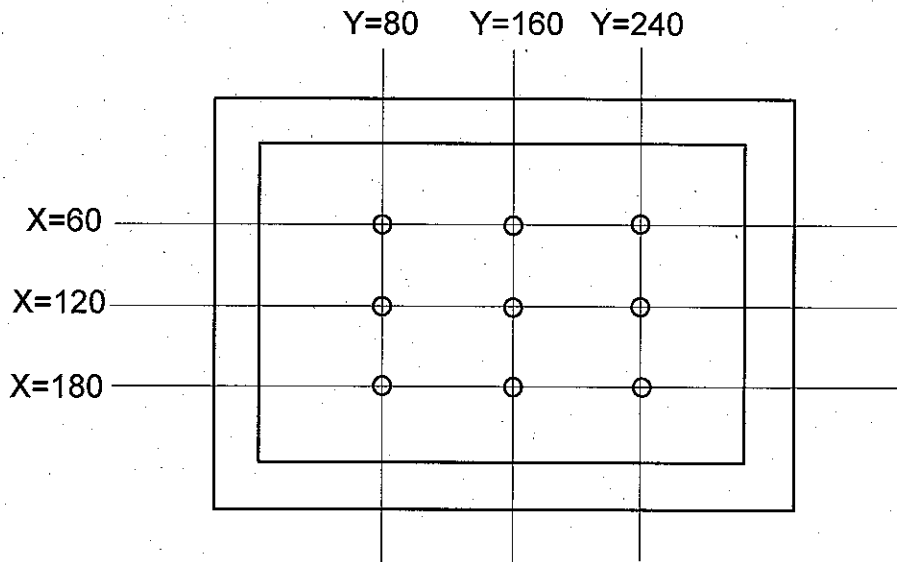

Definition of the brightness tolerance.

$$\left( \frac{\text{Max. or Min. Brightness} - \text{Average Brightness}}{\text{Average Brightness}} \right) \times 100$$

# 7. BLOCK DIAGRAM

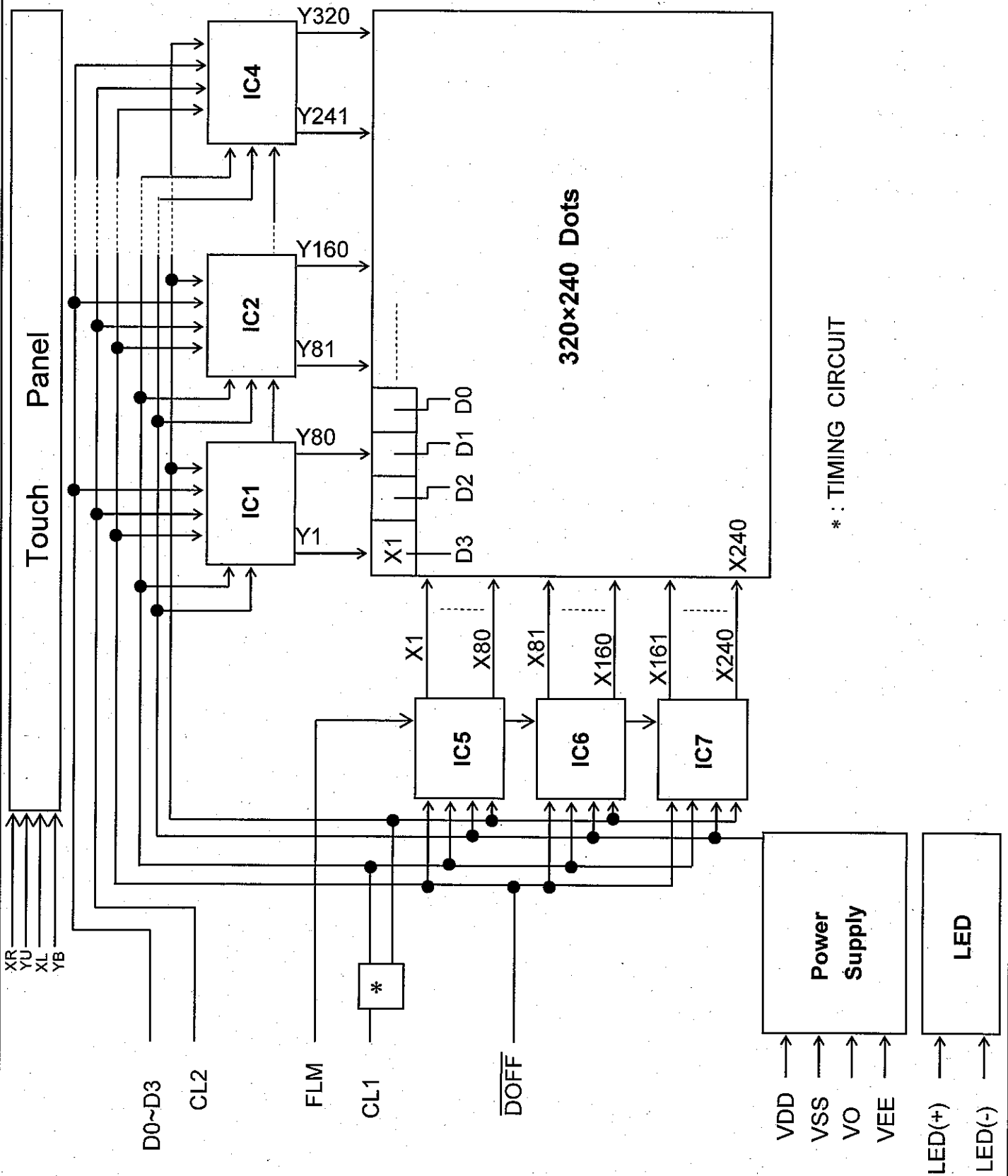

\* : TIMING CIRCUIT

# 8. INTERFACE TIMING CHART

## 8.1 INTERFACE TIMING CHART

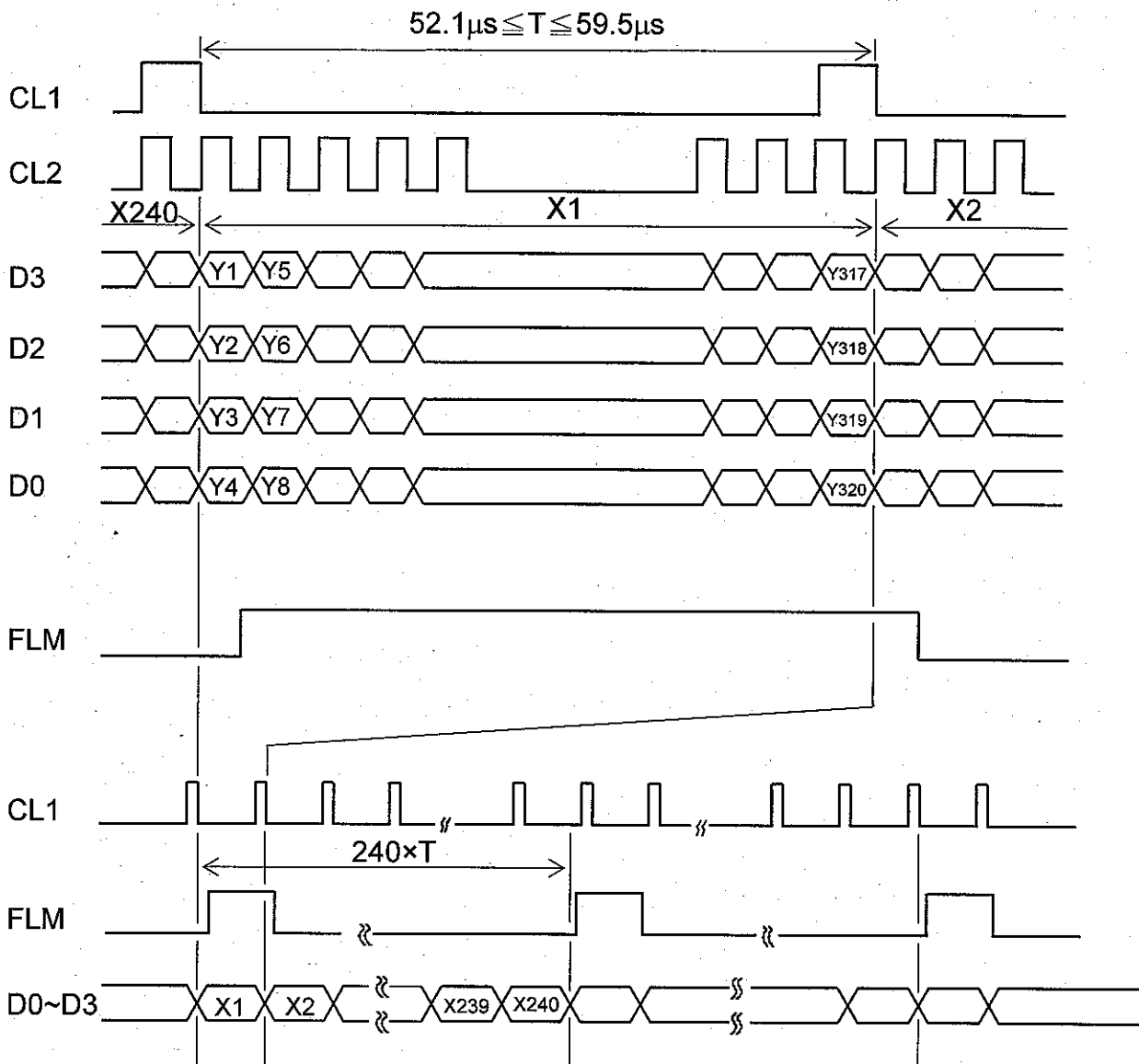

## 8.2 TIMING CHARACTERISTICS

ITEM	SYMBOL	MIN.	TYP.	MAX.	UNIT
CL2 frequency	fCP	-	-	6.5	MHz
CL2 pulse width	tw	45	-	-	ns
CL2 rise, fall time	tr,tf	-	-	15	ns
Data set up time	tDSU	30	-	-	ns
Data hold time	tDHD	30	-	-	ns
CL1 set up time	tLSU	80	-	-	ns
CL1 clock time	tLC	120	-	-	ns
"FLM" set up time	tSETUP	100	-	-	ns
"FLM" hold time	tHOLD	100	-	-	ns
"CL1" pulse width	twc	125	-	-	ns

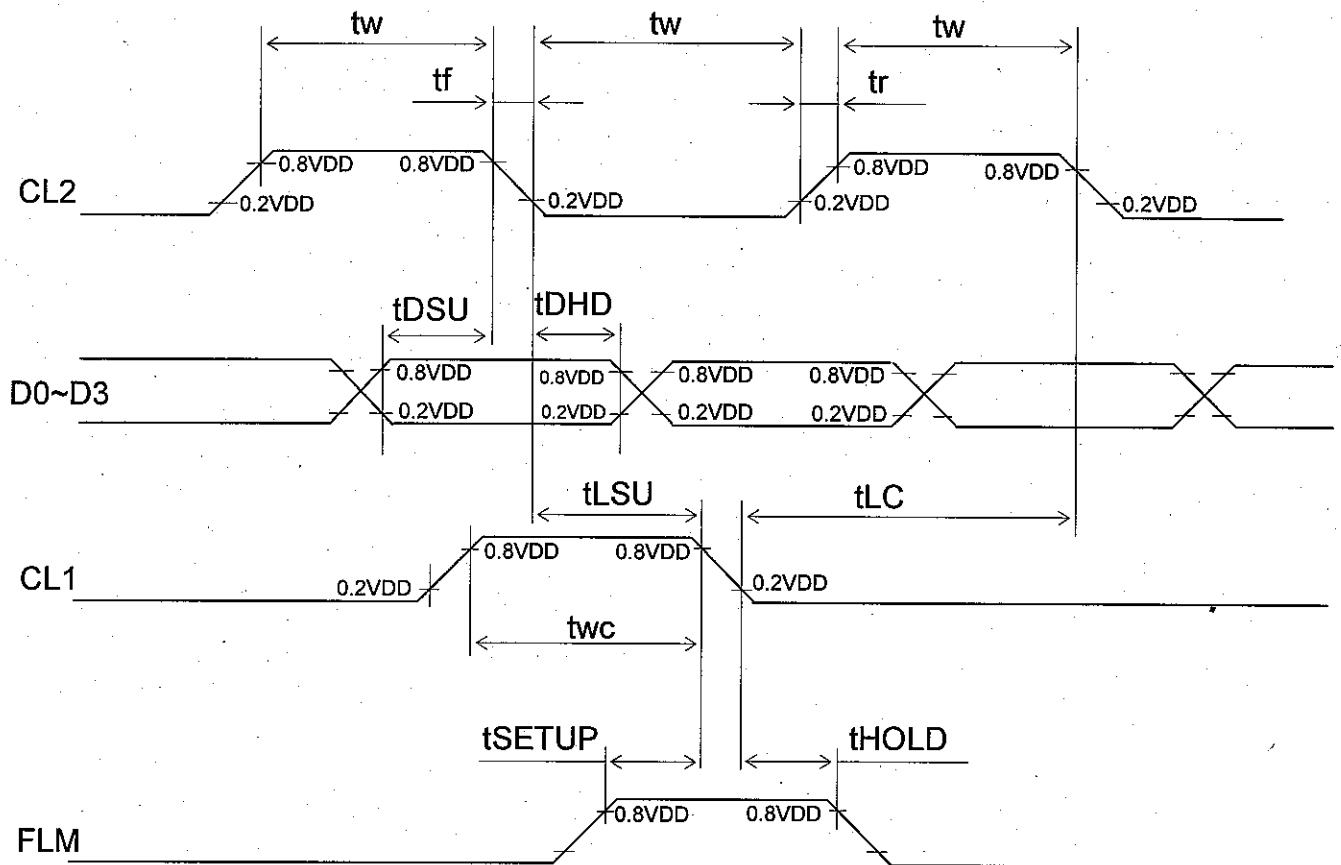

### 8.3 POWER ON/OFF TIMING SEQUENCE

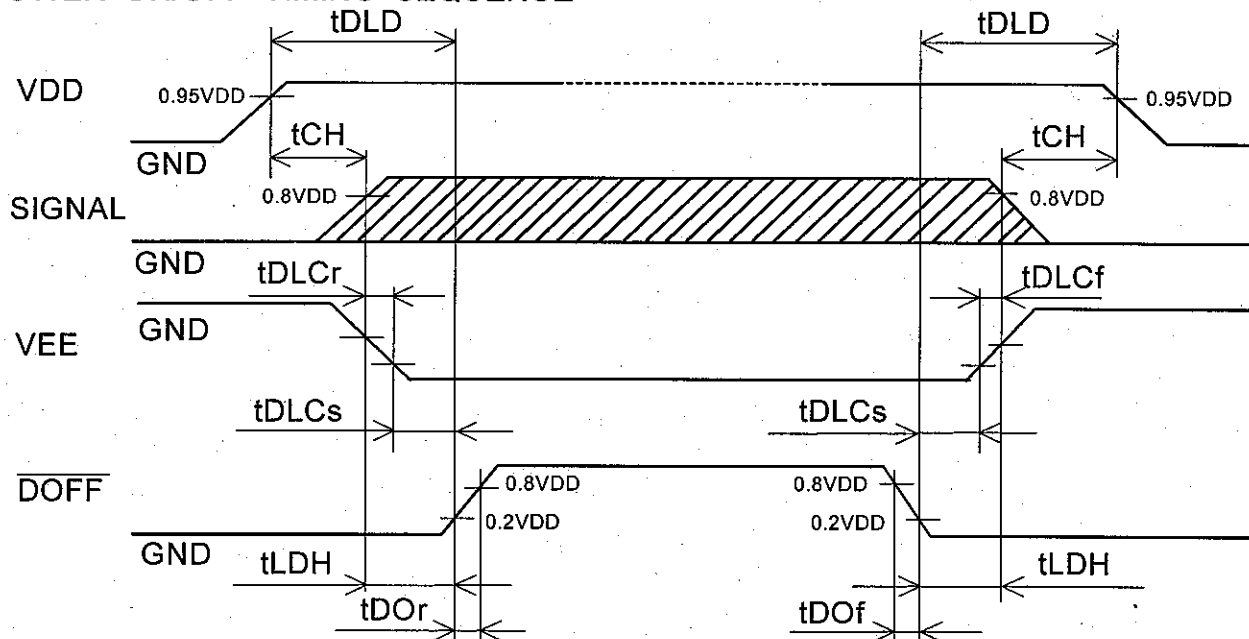

SYMBOL	MIN.	MAX.	UNIT	COMMENT
tDLd	50	-	ms	(Note 1)
tCH	0	30	ms	
tLDH	0	-	ms	
tDOr	-	100	ns	(Note 2)
tDOF	-	100	ns	
tDLcCr	0	-	ms	
tDLcCf	0	-	ms	
tDLcCs	20	-	ms	

Note 1: Please keep the specified sequence because wrong sequence may cause permanent damage to the LCD panel.

Note 2: HITACHI recommends you to use DOFF function. Display quality may deteriorate if you don't use DOFF function.

### 8.4 POWER SUPPLY FOR LCM (EXAMPLE)

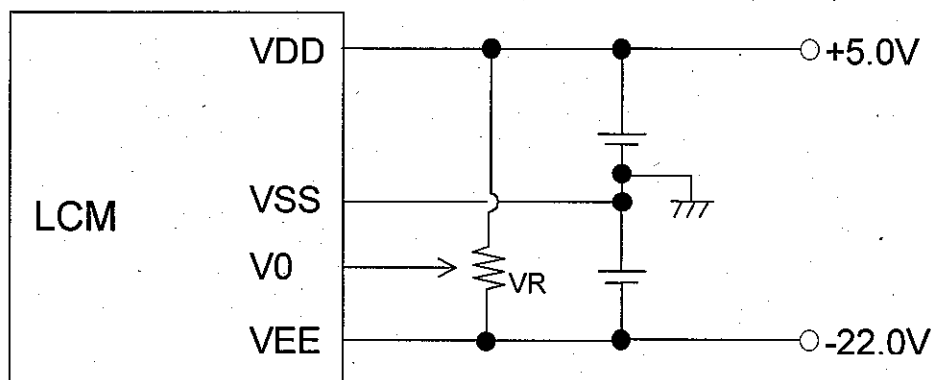

Note 1: VR : 10kΩ

9. OUTLINE DIMENSIONS  
9.1 OUTLINE DIMENSIONS

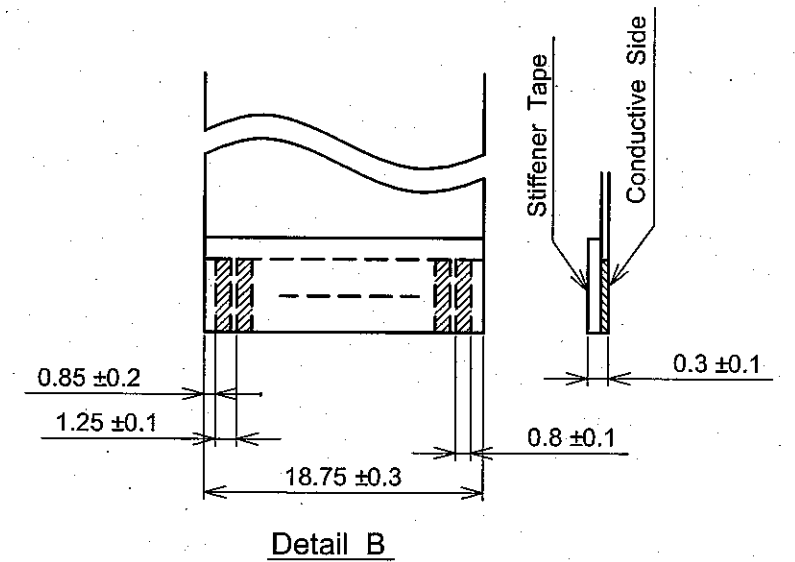
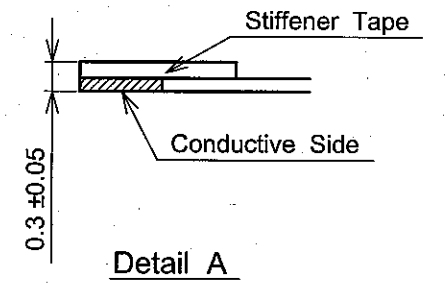
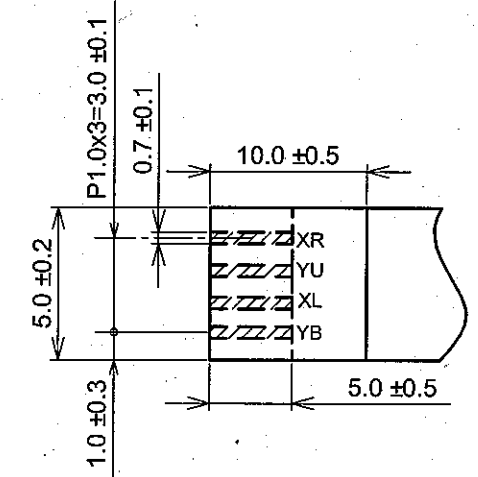
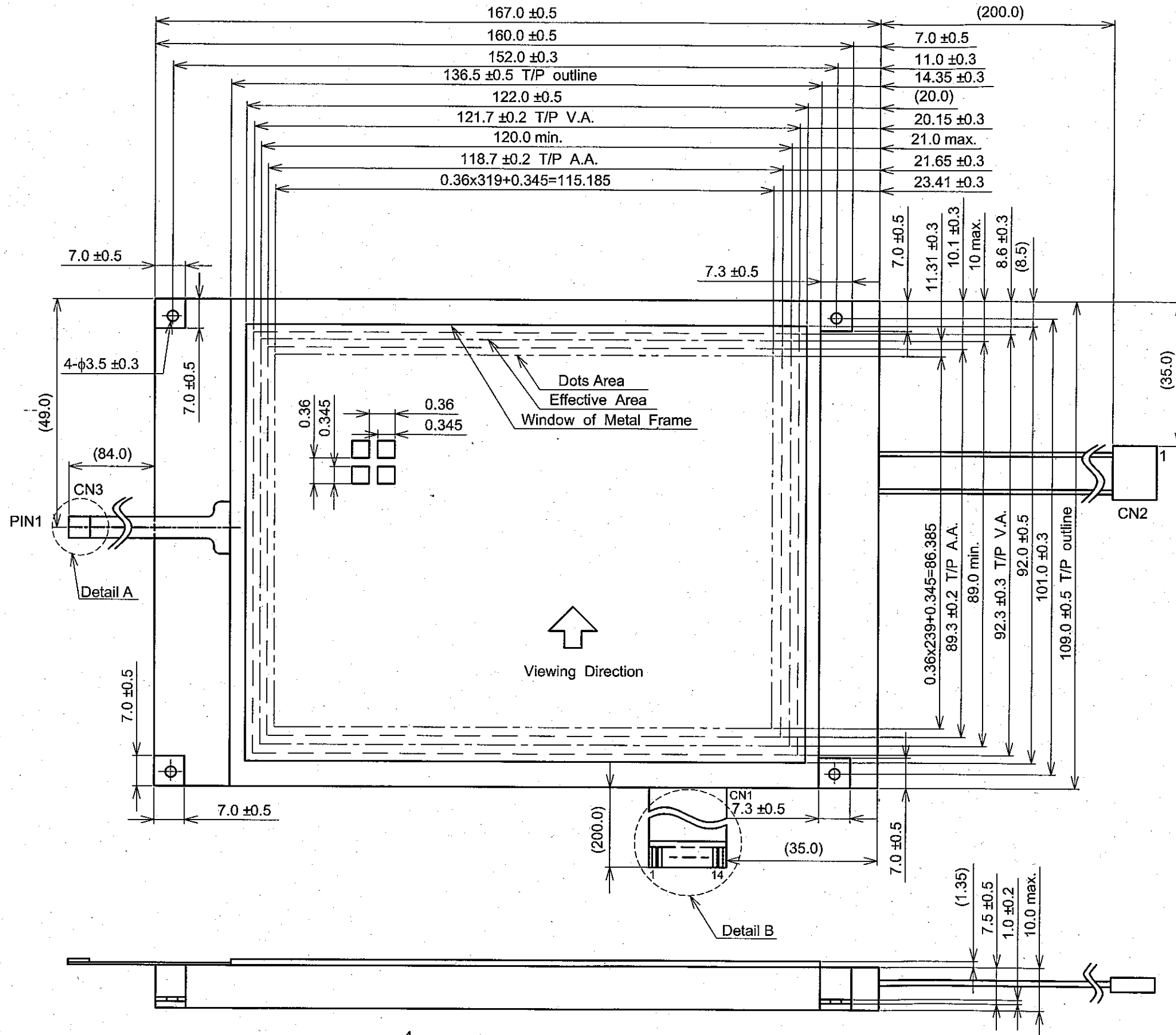

Note 1: Measurement when adding  $9.8 \times 10^4$  Pa at the measuring point.

Scale : NTS  
Unit : mm

## 9.2 DISPLAY PATTERN

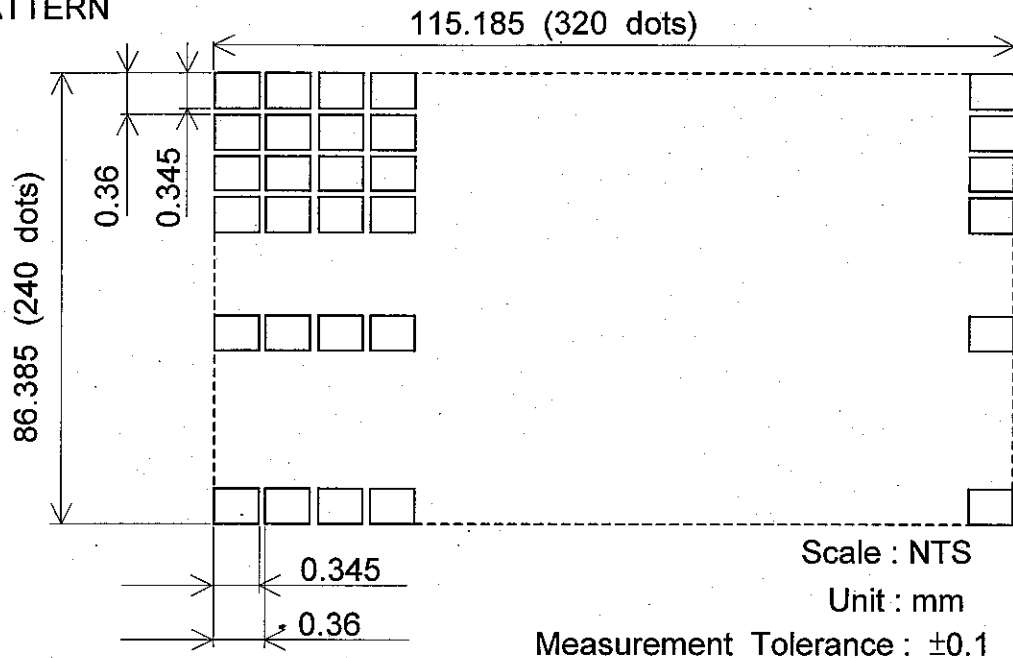

## 9.3 INTERFACE PIN CONNECTION

FPC : pitch 1.25mm 14 pins

INTERFACE	PIN No.	SIGNAL	LEVEL	FUNCTION	
LCM	CN1	1	D0	H/L	Display Data
		2	D1		
		3	D2		
		4	D3		
		5	DOFF	H/L	H : ON / L : OFF
		6	FLM	H	First Line Marker
		7	N.C	-	-
		8	CL1	H→L	Data Latch
		9	CL2	H→L	Data Shift
		10	VDD	-	Power Supply for Logic
		11	VSS	-	GND
		12	VEE	-	Power Supply for LC
		13	V0	-	Operating Voltage LC Driving
		14	VSS	-	GND

INTERFACE	PIN No.	SIGNAL	LEVEL	FUNCTION	
LCM	CN2	1	VLED(+)	-	Power Supply for LED
		2	N.C	-	-
		3	N.C	-	-
		4	VLED(-)	-	LED GND

LED I / F : J.A.E / IL-G-4S-S3C2-SA

INTERFACE	PIN No.	SIGNAL	FUNCTION
T/P	CN3	1	XR Analog Signal from Digitizer Right
		2	YU Analog Signal from Digitizer Up
		3	XL Analog Signal from Digitizer Left
		4	YB Analog Signal from Digitizer Bottom

FPC : pitch 1.0mm 4pins

Recommend suitable connector : (HIROSE) FH12-10(4)SA-ISH



## 10. APPEARANCE STANDARD

### 10.1 APPEARANCE INSPECTION CONDITION

Visual inspection should be done under the following condition.

- (1) The inspection should be done under in the dark room.
- (2) The CFL should be lighted with the prescribed inverter.
- (3) The distance between eyes of an inspector and the LCD module is 25cm.
- (4) The viewing zone is shown the figure.

Viewing angle  $\leq 25^\circ$

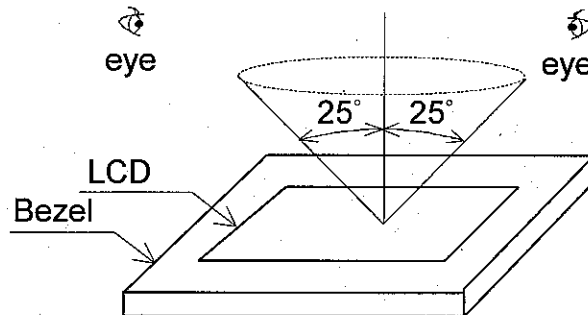

### 10.2 DEFINITION OF EACH ZONE

A zone : Within the effective area specified at page 9-1/2 of this document.

B zone : Area between the window of metal frame and the effective area line specified at page 9-1/2 of this document.

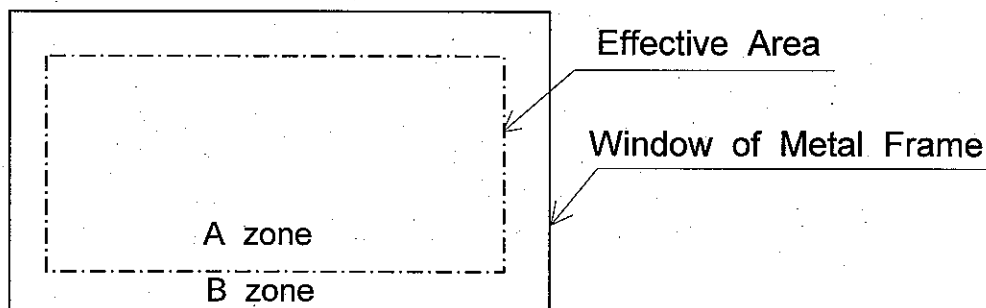

### 10.3 APPEARANCE SPECIFICATION

\*) If a problem occurs in respect to any of these items ,  
both parties(Customer and HITACHI) will discuss in more detail.

No.	ITEM	CRITERIA			A	B	
L C D	Scratches	Distinguished one is not acceptable (To be judged by HITACHI limit sample)			*	-	
	Dent	Same as Above			*	-	
	Wrinkles in polarizer	Same as Above			*	-	
	Bubbles	Average Diameter D(mm)		Maximum Number Acceptable		○	-
		D ≤ 0.2		Ignore			
		0.2 < D ≤ 0.3		12			
		0.3 < D ≤ 0.5		3			
		0.5 < D		None			
	Stains, Foreign Materials, Dark Spot	Filamentous			○	-	
		Length L(mm)	Width W(mm)	Maximum Number Acceptable			
		L ≤ 2.0	W ≤ 0.03	Ignore			
		L ≤ 3.0	0.03 < W ≤ 0.05	6			
		L ≤ 2.5	0.05 < W ≤ 0.1	1			
		Round					
		Average Diameter D(mm)	Maximum Number Acceptable	Minimum Space			
		D < 0.2	Ignore	-			
		0.2 ≤ D < 0.33	8	10mm			
		0.33 ≤ D	None	-			
	Total	Filamentous + Round = 10					
	Those wiped out easily are acceptable			○	○		
	Color Tone	To be judged by HITACHI limit sample			○	-	
	Color Uniformity	Same as above			○	-	
	Pinhole	Average Diameter D(mm)		Maximum Number Acceptable		○	-
D ≤ 0.15		Ignore					
0.15 < D ≤ 0.3		10					
C ≤ 0.015		Ignore					
Contrast Irregularity (Spot)	Average Diameter D(mm)	Contrast	Maximum Number Acceptable	Minimum Space	○	-	
	D ≤ 0.25	To be judged by HITACHI	Ignore	-			
	0.25 < D ≤ 0.35		10	20mm			
	0.35 < D ≤ 0.5		4	20mm			
	0.5 < D		None	-			

No.	ITEM					A	B
L C D	Contrast Irregularity (Line) (Filamentous)	Width D(mm)	Length L(mm)	Maximum Number Acceptable	Minimum Space	○	—
		$W \leq 0.25$	$L \leq 1.2$	2	20mm		
		$W \leq 0.2$	$L \leq 1.5$	3	20mm		
		$W \leq 0.15$	$L \leq 2.0$	3	20mm		
		$W \leq 0.1$	$L \leq 3.0$	4	20mm		
	Total				6		
	Rubbing Scratch	To be judged by HITACHI standard				○	—

Note 1 : Definition of average diameter (D)

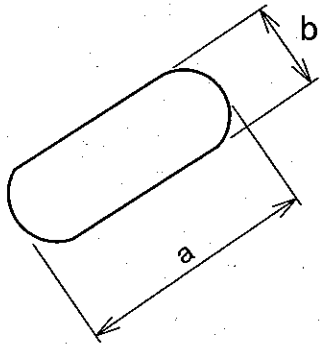

$$\frac{a+b}{2} = D \dots \dots \text{Average Diameter}$$

Note 2 : Definition of length (L) and width (W)

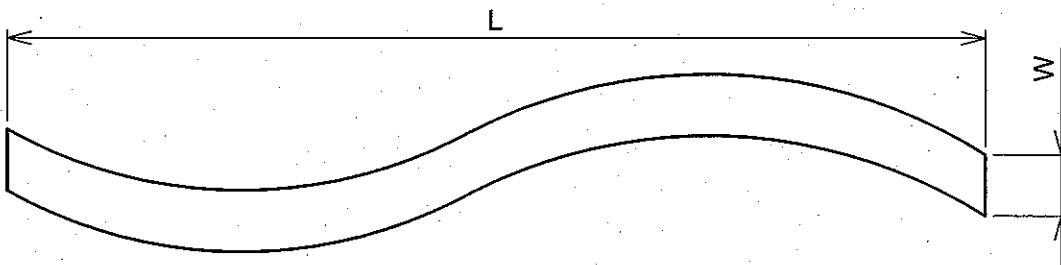

Note 3 : Definition of pinhole

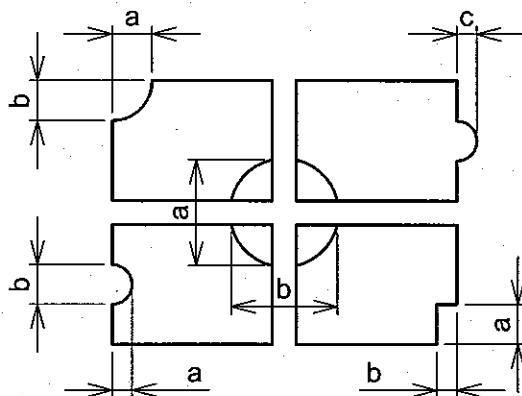

c : Saliency

## 11. PRECAUTION IN DESIGN

### 11.1 LC DRIVING VOLTAGE (VEE) AND VIEWING ANGLE RANGE

Setting VEE out of the recommended condition will be a cause for a change of viewing angle range.

### 11.2 PRECAUTIONS AGAINST STATIC CHARGE

As this module contains C-MOS LSIs, it is not strong against electrostatic discharge. Make certain that the operator's body is connected to the ground through a wrist band etc. And don't touch I/F pins directly.

### 11.3 POWER ON SEQUENCE

Input signals should not be applied to LCD module before power supply voltage is applied and reaches to specified voltage (VDD).

If above sequence is not kept, C-MOS LSIs of LCD modules may be damaged due to latch up problem.

### 11.4 PACKAGING

- (1) No leaving product is preferable in the place of high humidity for a long period of time. For their storage in the place where temperature is 35 °C or higher, special care to prevent them from high humidity is required. A combination of high temperature and high humidity may cause them polarization degradation as well as bubble generation and polarizer peel-off. Please keep the temperature and humidity within the specified range for use and storage.
- (2) Since polarizers tend to be easily damaged, They should be handled full with care so as not to get them touched, pushed or rubbed.
- (3) As the adhesives used for adhering polarizers are made of organic substances which will be deteriorated by a chemical reaction with such chemicals as acetone, toluene, ethanol and isopropyl alcohol. The following solvents are recommended for use:  
normal hexane  
Please contact us when it is necessary for you to use chemicals.
- (4) Lightly wipe to clean the dirty surface with absorbent cotton waste or other soft material like chamois, soaked in the chemicals recommended without scrubbing it hardly. To prevent the display surface from damage and keep the appearance in good state, it is sufficient, in general, to wipe it with absorbent cotton.
- (5) Immediately wipe off saliva or water drop attached on the display area because its long period adherence may cause deformation or faded color on the spot.
- (6) Foggy dew deposited on the surface due to coldness will be caused for polarizer damage, stain and dirt on product. When necessary to take out the products from some place at low temperature for test, etc. It is required for them to be warmed up in a container once at the temperature higher than that of room.
- (7) Touching the display area and contact terminals with bare hands and contaminating them are prohibited, because the stain on the display area and poor insulation between terminals are often caused by being touched by bare hands.  
(Some cosmetics are detrimental to polarizers.)

(8) In general the quality of glass is fragile so that it tends to be cracked or chipped in handling, specially on its periphery. Be careful not to give it sharp shock caused by dropping down, etc.

#### 11.5 CAUTION FOR OPERATION

- (1) It is an indispensable condition to drive LCDs within the specified voltage limit since the higher voltage than the limit causes the shorter LCD life. An electrochemical reaction due to direct current causes LCDs undesirable deterioration, so that the use of direct current driver should be avoided.
- (2) Response time will be extremely delayed at lower temperature than the operating temperature range and on the other hand at higher temperature LCDs show dark blue color in them. However those phenomena do not mean malfunction or out of order with LCDs which will come back in the specified operating temperature range.
- (3) If the display area is pushed hard during operation, some font will be abnormally displayed but it resumes normal condition after turning off once.
- (4) A slight dew depositing on terminals is a cause for electrochemical reaction resulting in terminal open circuit. Please operate the LCD module under the relative condition of 40°C 85%RH.

#### 11.6 STORAGE

In case of storing for a long period of time (for instance, for years) for the purpose of replacement use, the following ways are recommended.

- (1) Storage in a polyethylene bag with the opening sealed, so the fresh air will not be entered from outside.
- (2) Placing in a dark place where neither exposure to direct sunlight nor light is, keeping temperature in the range from 0 °C to 35 °C.
- (3) Storing with no touch on polarizer surface by anything else. (It is recommended to store them as they have been contained in the inner container at the time of delivery from us.)

#### 11.7 SAFETY

- (1) It is recommendable to crash damaged or unnecessary LCDs into pieces and wash off liquid crystal by either of solvents such as acetone and ethanol, which should be burned up later.
- (2) When any liquid leaked out of a damaged glass cell comes in contact with your hands, please wash it off well with soap and water.

## 12. DESIGNATION OF LOT MARK

### 12.1 LOT MARK

Lot mark is consisted of 4 digital number.

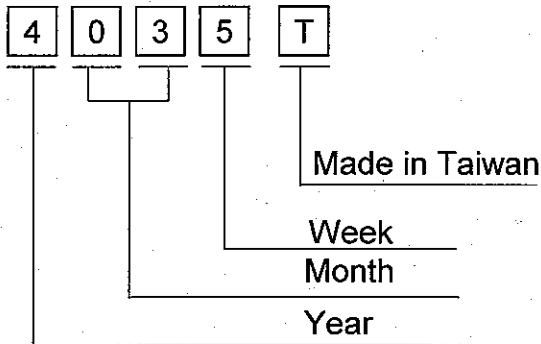

YEAR	FIGURE IN LOT MARK
2007	7
2008	8
2009	9
2010	0
2011	1

Note 1 Some products have alphabet at the end or the first.

MONTH	FIGURE IN LOT MARK	MONTH	FIGURE IN LOT MARK
Jan.	01	Jul.	07
Feb.	02	Aug.	08
Mar.	03	Sep.	09
Apr.	04	Oct.	10
May	05	Nov.	11
Jun.	06	Dec.	12

WEEK (DAY IN CALENDAR)	FIGURE IN LOT MARK
01~07	1
08~14	2
15~21	3
22~28	4
29~31	5

### 12.2 REVISION

REV No.	ITEM	LOT No.	PRODUCTION CONTROL No.
A			000001~

### 12.3 LOCATION OF LOT MARK on the back side of LCM

4035T

### 13. PRECAUTION FOR USE

13.1 A limit sample should be provided by the both parties on an occasion when the both parties agreed its necessity. Judgment by a limit sample shall take effect after the limit sample has been established and confirmed by the both parties.

13.2 On the following occasions, the handling of the problem should be decided through discussion and agreement between responsible persons of the both parties.

- (1) When a question is arisen in the specifications.
- (2) When a new problem is arisen which is not specified in this specifications.
- (3) When an inspection specifications change or operating condition change in customer is reported to HITACHI, and some problem is arisen in this specification due to the change.
- (4) When a new problem is arisen at the customer's operating set for sample evaluation in the customer site.

The precaution that should be observed when handling LCM have been explained above. If any points are unclear or if you have any request, please contact HITACHI.

## 14. TOUCH PANEL SPECIFICATION

### 14.1 RATINGS

#### 14.1.1 ABSOLUTE MAXIMUM RATINGS

ITEM	SPECIFICATION	COMMENT
Operating Voltage	7V	Without Condensation
Contact Current	20mA	

#### 14.1.2 OPERATING CONDITIONS

ITEM	SPECIFICATION
Operating Voltage	5.0 / 3.3 VDC
Contact Current	10 ~ 20 mA
Actuation Force	80g max. (R8,Silicone rubber)

### 14.2 SURFACE HARDNESS

2H

### 14.3 OPTICAL CHARACTERISTICS

14.3.1 TRANSPARENCY : 76%.min.  
(WAVE LENGTH : 450 ~ 700nm)

### 14.4 ELECTRICAL CHARACTERISTICS

#### 14.4.1 CONDUCTIVE RESISTANCE

TERMINAL	CONDUCTIVE RESISTANCE
XR-XL	150~1300Ω
YU-YB	150~1300Ω

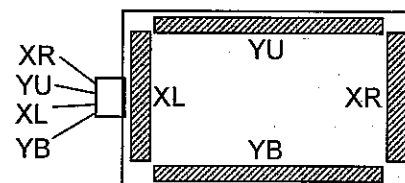

#### 14.4.2 INSULATION RESISTANCE

TERMINAL	INSULATION RESISTANCE	TESTING VOLTAGE
X-Y	20MΩ	25VDC

#### 14.4.3 BOUNCE CHATTERING

10ms max.



14.4.4 LINEARITY

(1) LINEARITY

Linearity Deviation : 2% max.

(2) TESTING CIRCUIT

(a) X axis linearity testing method , 100g , VXR-VXL=5V , VOUT=VYU.

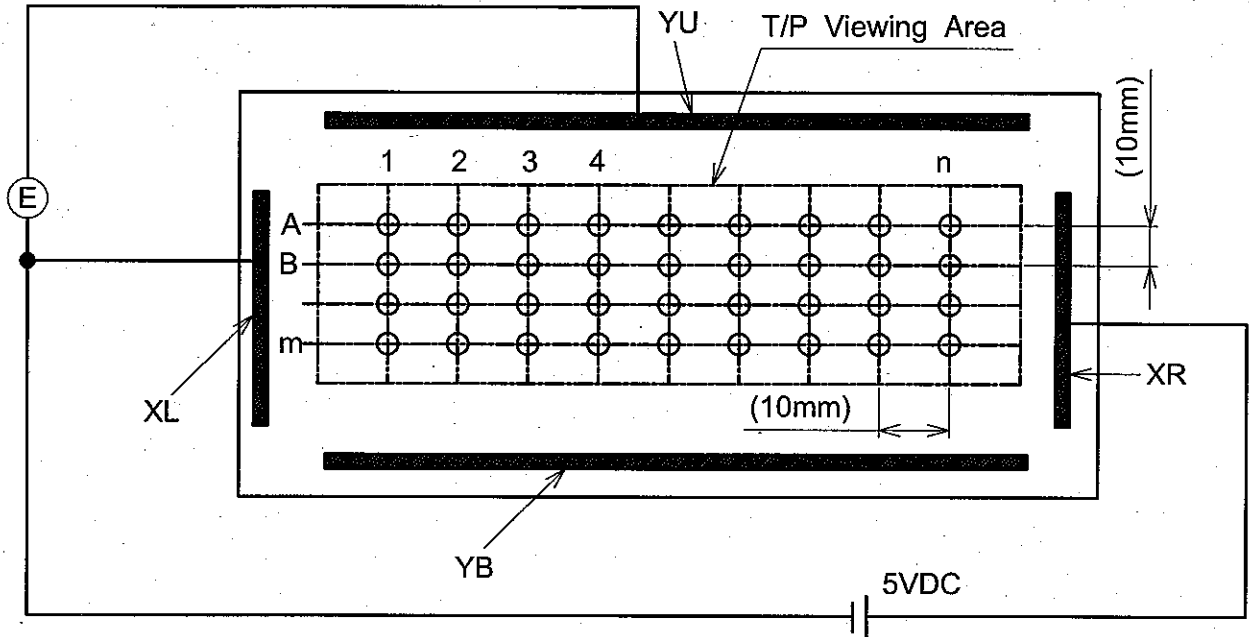

(b) Y axis linearity method , 100g VYU-VYB=5V , VOUT=VXR

(3) CALCULATION

(a) X axis linearity

$$\text{LINEARITY} = \frac{\Delta E \text{ max.}}{EA1 - EAn} \times 100(\%)$$

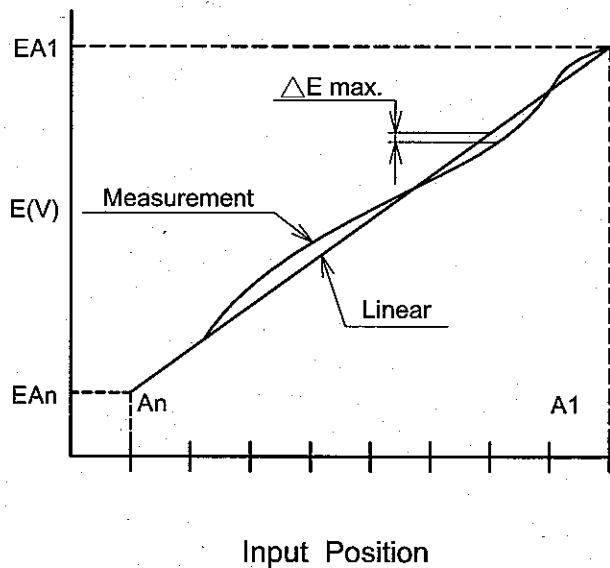

#### 14.5 ENVIRONMENTAL TESTING

ITEM	CONDITIONS	CRITERIA
High Temperature Storage	60°C : 120h & 25°C : 24h	After testing must to meet the specifications of the Electrical, Mechanical & Optical Characteristics.
Low Temperature Storage	-20°C : 120h & 25°C : 24h	
Temperature Cycle	-20°C ↔ 70°C : 10 Cycles within (30) (60) (30) : minutes & 25°C : 24h (Without Condensation)	
Humidity Storage	60°C , 90%RH. 120h	
Durability for Keystroke	150g , R8, HS40 Silicon Rubber (Speed : 330mm/sec)  : 1000000 Activations	

#### 14.6 APPEARANCE SPECIFICATION

No.	ITEM	CRITERIA			A	B
T / P	Hair Flaws	FILAMENTOUS			O	-
		Length L(mm)	Width W(mm)	Maximum Number Acceptable		
		$L \leq 12$	$W \leq 0.05$	Ignore		
		$L \leq 5$	$0.05 < W \leq 0.1$	3		
		$L > 2$	$0.1 < W$	None		
	Dot-shaped Impurities	Average Diameter D(mm)		Maximum Number Acceptable	O	-
		$D \leq 0.1$		Ignore		
		$0.1 < D \leq 0.3$		5		
		$0.3 < D$		None		
	Scratch	FILAMENTOUS			O	-
		Length L(mm)	Width W(mm)	Maximum Number Acceptable		
		$L \leq 12$	$W \leq 0.05$	Ignore		
		$L \leq 12$	$0.05 < W \leq 0.1$	5		
		$L > 12$	$0.1 < W$	None		

### 14.6.3 GLASS INDENTATION

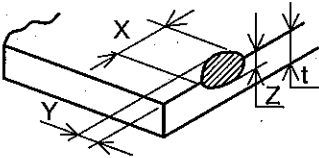
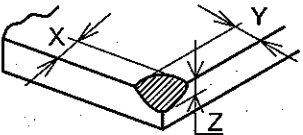
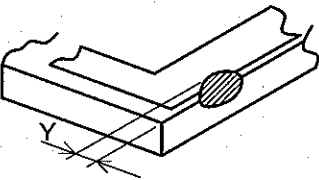
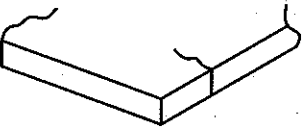
ITEM	SPECIFICATIONS						
Common Indentation	 <table border="1" data-bbox="1054 264 1337 353"> <tr> <td>X</td> <td>Y</td> <td>Z</td> </tr> <tr> <td><math>\leq 5.0</math></td> <td><math>\leq 3.0</math></td> <td><math>\leq t</math></td> </tr> </table> <p data-bbox="1046 394 1337 483">But, indentation can not including seal area. t : Glass thickness.</p>	X	Y	Z	$\leq 5.0$	$\leq 3.0$	$\leq t$
X	Y	Z					
$\leq 5.0$	$\leq 3.0$	$\leq t$					
Corner Broken	 <table border="1" data-bbox="1054 551 1337 640"> <tr> <td>X</td> <td>Y</td> <td>Z</td> </tr> <tr> <td><math>\leq 2.0</math></td> <td><math>\leq 5.0</math></td> <td><math>\leq t</math></td> </tr> </table> <p data-bbox="1046 689 1337 752">But, indentation can not including seal area.</p>	X	Y	Z	$\leq 2.0$	$\leq 5.0$	$\leq t$
X	Y	Z					
$\leq 2.0$	$\leq 5.0$	$\leq t$					
Indentation Within Pattern	 <p data-bbox="975 954 1390 1043"><math>Y \leq 1</math> Is ignore But, Must to meet the specification of conducting pattern indentation.</p>						
Proceeding Crack	 <p data-bbox="986 1155 1050 1182">None</p>						

### 14.6.4 BLISTERING (PUFFINESS) : 0.4 mm max.

