

Doc. Number: DN0226398

- Tentative Specification
 Preliminary Specification
 Approval Specification

MODEL NO.: R190E5
SUFFIX: L01

Customer:	
APPROVED BY	SIGNATURE
Name / Title _____	_____
Note	
_____ Please return 1 copy for your confirmation with your signature and comments.	

Approved By	Checked By	Prepared By
yuhsiang.chang(張喻翔/514-10922)	yuhsiang.chang(張喻翔/514-10922)	aston.yy.chen(陳彥宇/514-10914)
2012-01-09 16:25:01 CST	2011-12-30 16:17:42 CST	2011-12-29 14:24:02 CST

CONTENTS

1. GENERAL DESCRIPTION	5
1.1 OVERVIEW	5
1.2 GENERAL SPECIFICATIONS	5
2. MECHANICAL SPECIFICATIONS	5
3. ABSOLUTE MAXIMUM RATINGS	5
3.1 ABSOLUTE RATINGS OF ENVIRONMENT	5
3.2 ELECTRICAL ABSOLUTE RATINGS	6
3.2.1 TFT LCD MODULE	6
3.2.2 BACKLIGHT UNIT	6
4. ELECTRICAL SPECIFICATIONS	7
4.1 FUNCTION BLOCK DIAGRAM	7
4.2. INTERFACE CONNECTIONS	7
4.3 ELECTRICAL CHARACTERISTICS	9
4.3.1 LCD ELETRONICS SPECIFICATION	9
4.3.2 Vcc Power Dip Condition	11
4.3.3 BACKLIGHT UNIT	11
4.3.4 INVERTER ELECTRICAL CHARACTERISTIC	13
4.3.5 INVERTER INPUT SIGNAL	13
4.4 LVDS INPUT SIGNAL SPECIFICATIONS	15
4.4.1 LVDS DATA MAPPING TABLE	15
4.4.2 COLOR DATA INPUT ASSIGNMENT	16
4.5 DISPLAY TIMING SPECIFICATIONS	17
4.6 POWER ON/OFF SEQUENCE	19
5. OPTICAL CHARACTERISTICS	21
5.1 OPTICAL SPECIFICATIONS	21
6. RELIABILITY TEST ITEM	25
7. PACKING	26
7.1 PACKING SPECIFICATIONS	26
7.2 PACKING METHOD	26
7.3 PALLET	27
8. CMI MODULE LABEL	28
9. PRECAUTIONS	29
9.1 ASSEMBLY AND HANDLING PRECAUTIONS	29
9.2 STORAGE PRECAUTIONS	29
9.3 OPERATION PRECAUTIONS	29

9.4 SAFETY PRECAUTIONS	30
9.5 SAFETY STANDARDS	30
9.6 OTHER	30
Appendix. OUTLINE DRAWING	31

www.panelook.com

REVISION HISTORY

Version	Date	Page	Description
2.1	Sep.30, 2010	All	Modify the format of spec.
		5	Sec.2, modify mechanical specification
		7	Sec. 4.1, modify function block diagram
		8	Sec. 4.2, modify Note(2), first pixel is even
		11	Sec. 4.3.3, modify lamp input voltasge
		13	Sec. 4.3.4, modify inverter input current Modify inverter input power Modify inverter operating frequency Modify the definition of inverter output current
		15	Sec. 4.4.1, LVDS SEL=Ground or open Add JEITA mode LVDS data mapping table
		17	Sec. 4.5, Display timing specification, max LVDS clock max. period change to 21.8ns
		19	Remove LVDS Rx interface timing diagram
		20,21	Sec. 4.6, modify the timing definition of power on-off sequence
2.2	Dec 20, 2011	26	Add Sec.6, reliability test item
		5	Sec. 1.2, 1. Luminance of White 1500Cd/m ² to 1300 Cd/m ² 2. Power consumption total 45.84W to 44.64W 3. Power consumption BL 42W to 40.8W
		6	Sec 3.2.2 Lamp voltage : min. 639 to 648V _{rms} typ. 710 to 720V _{rms} max. 781 to 792V _{rms}
		12	Sec 4.3.3 Lamp input voltage : min. 657 to 648V _{rms} typ. 730 to 720V _{rms} max. 803 to 792V _{rms}
		14	Sec 4.3.4 1. Input current 3.5 to 3.4A 2. Input power 42 to 40.8W
		21	Sec. 5.1, Center Luminance of White Typ. 1500Cd/m ² to 1300 Cd/m ² Min. 1200Cd/m ² to 1000 Cd/m ²

1. GENERAL DESCRIPTION

1.1 OVERVIEW

R190E5-L01 is an 19.0" TFT Liquid Crystal Display module with 14 CCFL Backlight unit and 30 pins and one port 2ch-LVDS interface. This module supports 1280 x 1024 SXGA mode and displays monochrome driven by 8bit drivers. The LCD module includes built-in inverter for Backlight.

1.2 GENERAL SPECIFICATIONS

Item	Specification	Unit	Note
Screen Size	19.0" real diagonal		
Driver Element	a-si TFT active matrix	-	-
Pixel Number	1280(x3) x 1024	pixel	-
Pixel Pitch	0.294 (H) x 0.294 (V)	mm	-
Pixel Arrangement	Sub-pixel Vertical stripe	-	-
Display Colors	8-bit per1(one) sub-pixel, grayscale	color	-
Transmissive Mode	Dual domain IPS, Normally Black	-	-
Surface Treatment	AG type	-	-
Luminance, White	1300	Cd/m ²	-
Power Consumption	Total 44.64W (typ.) @ cell 3.84 W (typ.), BL 40.8 W (typ.)		(1)

Note (1) The specified power consumption: Total= cell (reference 4.3.1)+ BL (reference 4.3.4)

2. MECHANICAL SPECIFICATIONS

Item		Min.	Typ.	Max.	Unit	Note
Module Size	Horizontal (H)	395.5	396	397.5	mm	(1)
	Vertical (V)	323.5	324	324.5	mm	
	Thickness (T)	-	27.1	27.6	mm	
Bezel Area	Horizontal	380.15	380.3	380.45	mm	
	Vertical	304.85	305	305.15	mm	
Active Area	Horizontal	-	376.32	-	mm	
	Vertical	-	301.056	-	mm	
Weight		-	1700	1800	g	

Note (1) Please refer to the attached drawings for more information of front and back outline dimensions.

3. ABSOLUTE MAXIMUM RATINGS

3.1 ABSOLUTE RATINGS OF ENVIRONMENT

Item	Symbol	Value		Unit	Note
		Min.	Max.		
Storage Temperature	TST	-20	60	°C	(1)
Operating Ambient Temperature	TOP	0	55	°C	(1), (2)

Note (1)

(a) 90 %RH Max. (Ta ≤ 40 °C).

(b) Wet-bulb temperature should be 39 °C Max. (Ta > 40 °C).

(c) No condensation.

Note (2) The temperature of panel surface should be 0 °C min. and 60 °C max.

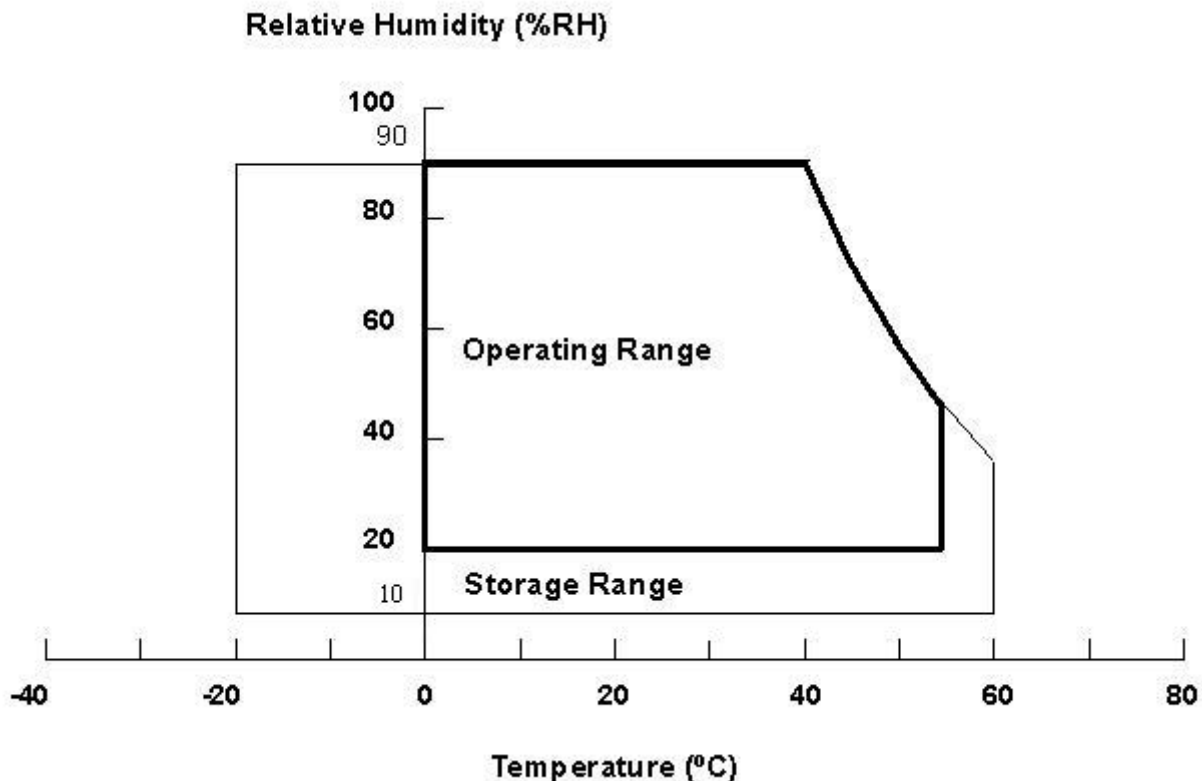

3.2 ELECTRICAL ABSOLUTE RATINGS

3.2.1 TFT LCD MODULE

Item	Symbol	Value		Unit	Note
		Min.	Max.		
Power Supply Voltage	VCCS	-0.3	13.2	V	(1)
Logic Input Voltage	V _{IN}	-0.3	4.3	V	

3.2.2 BACKLIGHT UNIT

Item	Symbol	Value			Unit	Note
		Min.	Typ	Max.		
Lamp Voltage	V _L	648	720	792	V _{RMS}	(1), (2)
Lamp current	I _L	3.7	4.2	4.7	mA _{RMS}	
Lamp frequency	F _L	40	---	80	KHz	

Note (1) Permanent damage to the device may occur if maximum values are exceeded. Function operation should be restricted to the conditions described under Normal Operating Conditions.

Note (2) Specified values are for lamp (Refer to 4.3.3 and 4.3.4 for further information).

4. ELECTRICAL SPECIFICATIONS

4.1 FUNCTION BLOCK DIAGRAM

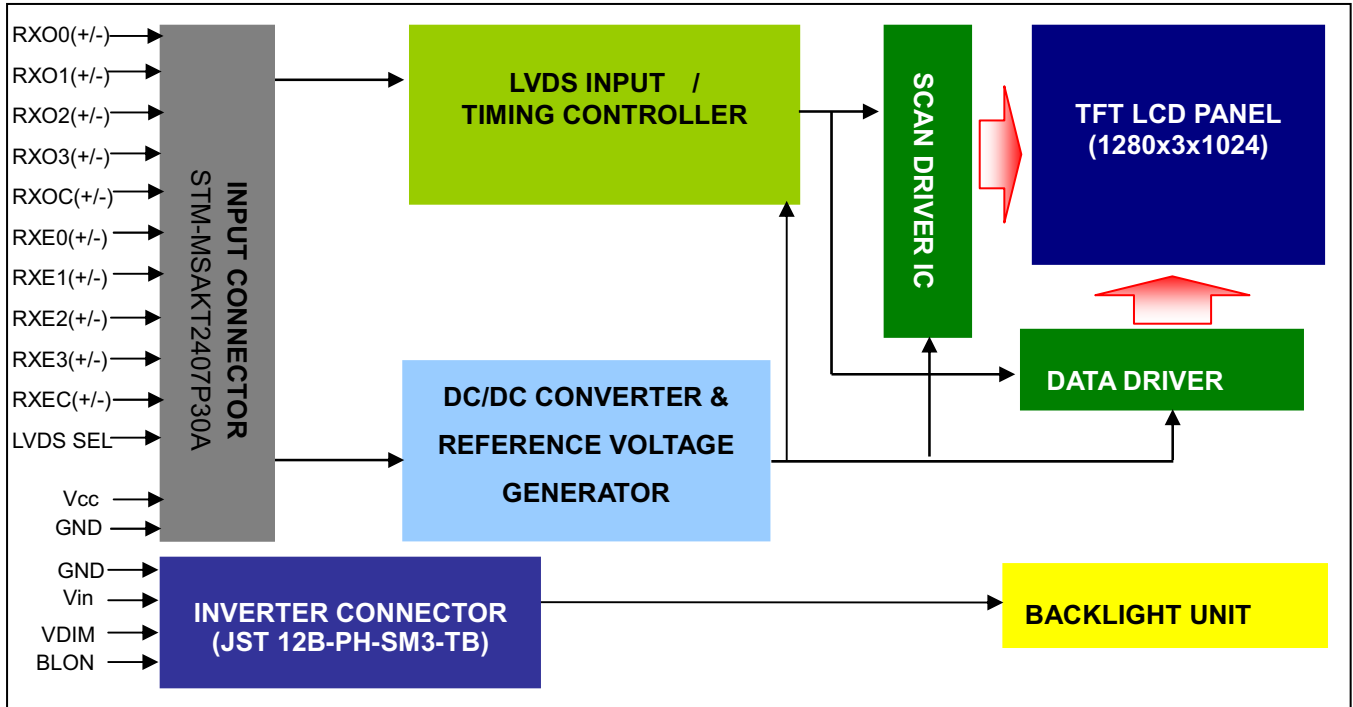

4.2. INTERFACE CONNECTIONS

PIN ASSIGNMENT

Pin	Name	Description
1	RX00-	Negative LVDS differential data input. Channel O0 (odd)
2	RX00+	Positive LVDS differential data input. Channel O0 (odd)
3	RX01-	Negative LVDS differential data input. Channel O1 (odd)
4	RX01+	Positive LVDS differential data input. Channel O1 (odd)
5	RX02-	Negative LVDS differential data input. Channel O2 (odd)
6	RX02+	Positive LVDS differential data input. Channel O2 (odd)
7	GND	Ground
8	RXOC-	Negative LVDS differential clock input. (odd)
9	RXOC+	Positive LVDS differential clock input. (odd)
10	RX03-	Negative LVDS differential data input. Channel O3(odd)
11	RX03+	Positive LVDS differential data input. Channel O3 (odd)
12	RXE0-	Negative LVDS differential data input. Channel E0 (even)
13	RXE0+	Positive LVDS differential data input. Channel E0 (even)
14	GND	Ground
15	RXE1-	Negative LVDS differential data input. Channel E1 (even)
16	RXE1+	Positive LVDS differential data input. Channel E1 (even)
17	GND	Ground
18	RXE2-	Negative LVDS differential data input. Channel E2 (even)
19	RXE2+	Positive LVDS differential data input. Channel E2 (even)
20	RXEC-	Negative LVDS differential clock input. (even)
21	RXEC+	Positive LVDS differential clock input. (even)
22	RXE3-	Negative LVDS differential data input. Channel E3 (even)
23	RXE3+	Positive LVDS differential data input. Channel E3 (even)

24	GND	Ground
25	LVDS_SEL	0:VESA Mode; 1:JEITA Mode (0 : Ground ; 1 : 3.3V) ; default is zero
26	NC	Not connection, this pin should be open
27	NC	Not connection, this pin should be open
28	V _{CC} (12V)	+12.0V power supply
29	V _{CC} (12V)	+12.0V power supply
30	V _{CC} (12V)	+12.0V power supply

Note (1) Connector Part No.: MSAKT2407P30A (STM)

Note (2) The first pixel is even.

Note (3) Input signal of even and odd clock should be the same timing.

Note (4) The module uses a 100-ohm resistor between positive and negative data lines of each receiver input

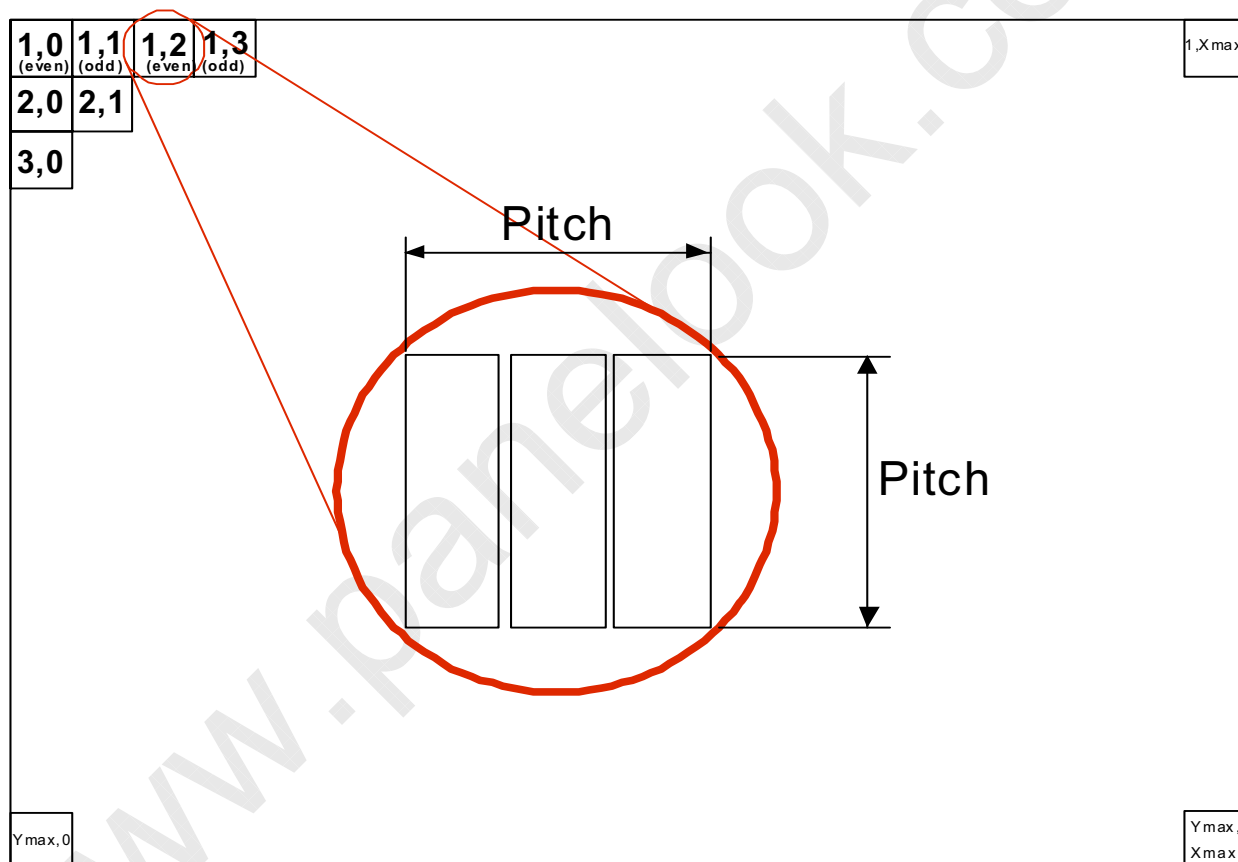

4.3 ELECTRICAL CHARACTERISTICS

4.3.1 LCD ELETRONICS SPECIFICATION

Parameter	Symbol	Value			Unit	Note
		Min.	Typ.	Max.		
Power Supply Voltage	V _{CC}	11.4	12	12.6	V	-
Ripple Voltage	V _{RP}	-	-	300	mV	-
Rush Current	I _{RUSH}	-	-	3	A	(2)
Power Supply Current	White	-	(0.31)	0.434	A	(3)a
	Black	-	(0.21)	0.310	A	(3)b
	Vertical Stripe	-	(0.32)	0.448	A	(3)c
Power Consumption	PLCD	-	3.84	5.65	Watt	(4)
LVDS differential input voltage	V _{id}	100	-	600	mV	
LVDS common input voltage	V _{ic}	1.0	1.2	1.4	V	
Logic High Input Voltage	V _{IH}	2.64	-	-	V	
Logic Low Input Voltage	V _{IL}	-	-	0.66	V	

Note (1) The ambient temperature is $T_a = 25 \pm 2$ °C.

Note (2) Measurement Conditions:

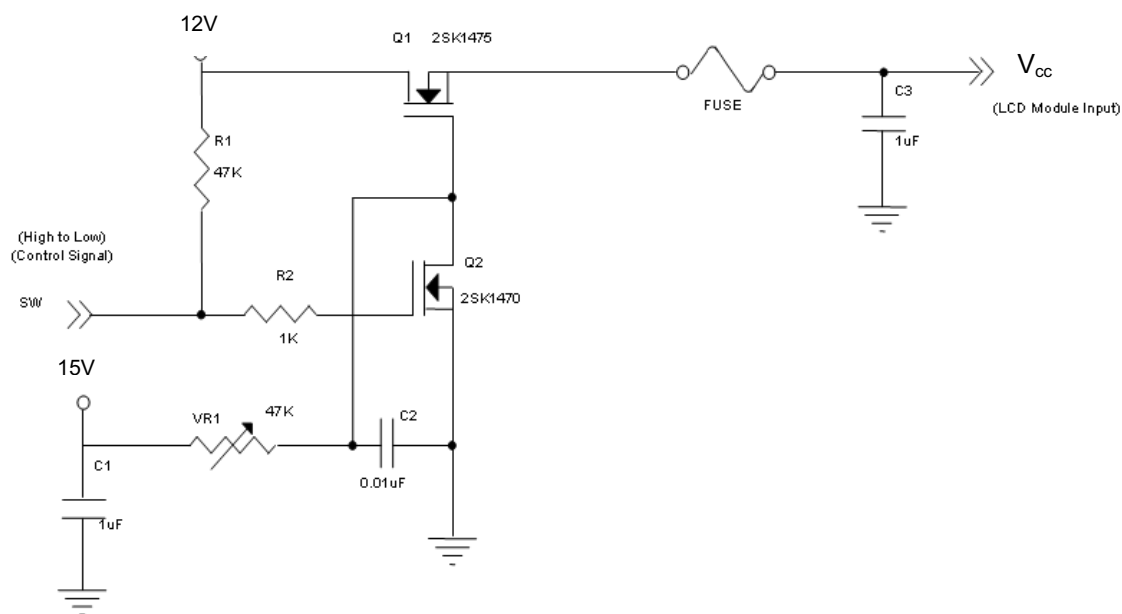

V_{CC} rising time is 470μs

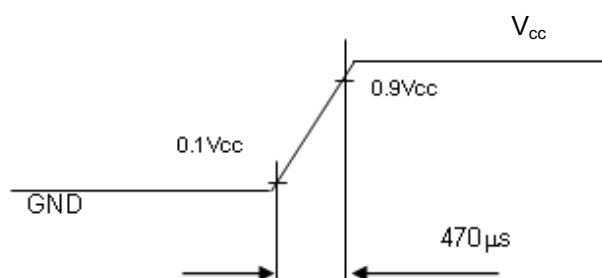

Note (3) The specified power supply current is under the conditions at $V_{cc} = 12.0\text{ V}$, $T_a = 25 \pm 2\text{ }^\circ\text{C}$, $F_r = 60\text{ Hz}$, whereas a power dissipation check pattern below is displayed.

a. White Pattern



Active Area

b. Black Pattern

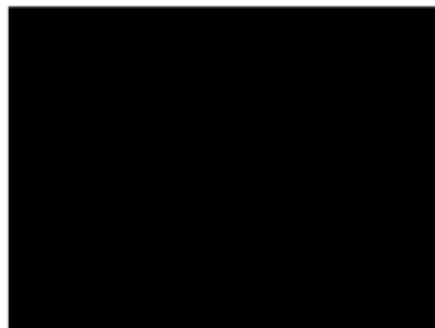

Active Area

c. Vertical Stripe Pattern

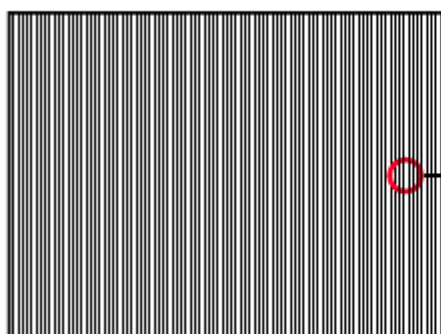

Active Area

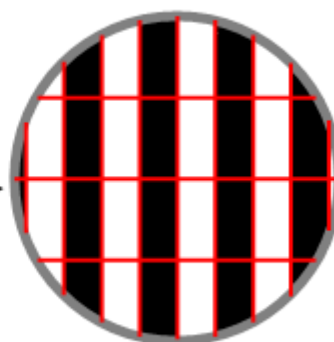

Note (4) The power consumption is specified at the pattern with the maximum current.

Note (5) VID waveform condition

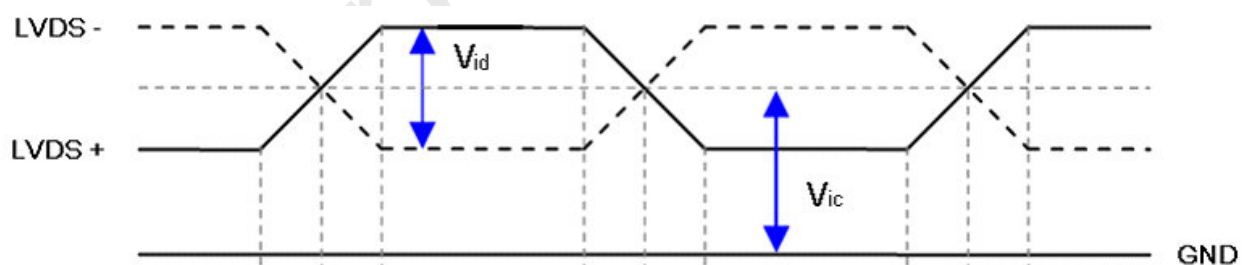

4.3.2 Vcc Power Dip Condition

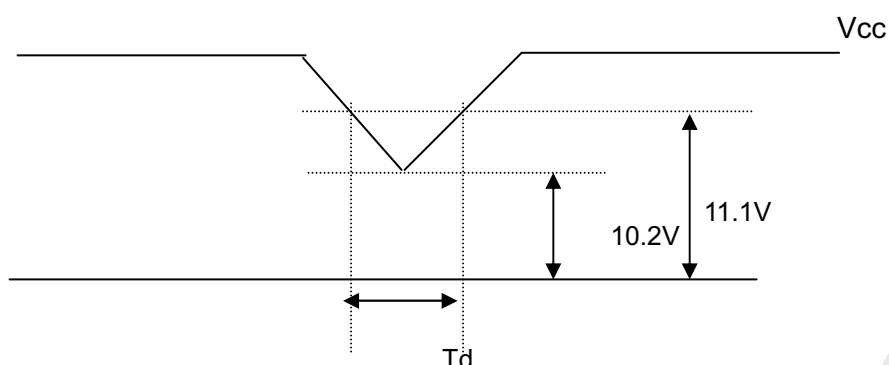

Dip condition: $10.2V \leq V_{cc} \leq 11.1V, T_d \leq 20ms$

4.3.3 BACKLIGHT UNIT

Parameter	Symbol	Value			Unit	Note
		Min.	Typ.	Max.		
Lamp Input Voltage	V_L	648	720	792	V_{RMS}	$I_L = 4.2mA$
Lamp Current	I_L	3.7	4.2	4.7	mA_{RMS}	(1)
Lamp Turn On Voltage	V_S	---	1065(0 °C)	1330(0 °C)	V_{RMS}	(2)
		---	850(25 °C)	1065(25 °C)	V_{RMS}	(2)
Operating Frequency	F_L	40	---	60	KHZ	(3)
Lamp Life Time	L_{BL}	50,000	---	---	Hrs	(4)

Note (1) Lamp current is measured by utilizing high frequency current meters as shown below:

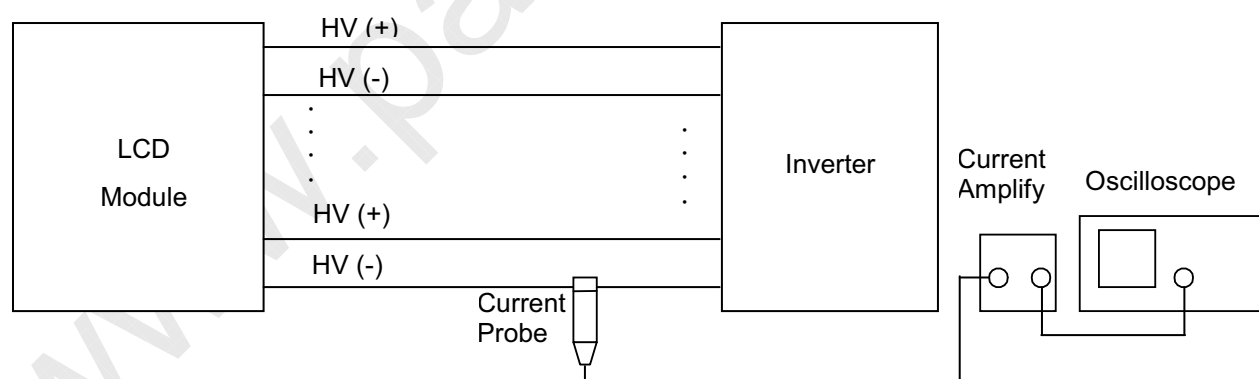

Note (2) The voltage shown above should be applied to the lamp for more than 1 second after startup. Otherwise the lamp may not be turned on.

Note (3) The lamp frequency may produce interference with horizontal synchronous frequency from the display, and this may cause line flow on the display. In order to avoid interference, the lamp frequency should be detached from the horizontal synchronous frequency and its harmonics as far as possible.

Note (4) The lifetime of lamp can be defined as the time in which it continues to operate under the condition $T_a = 25 \pm 2 \text{ }^\circ\text{C}$ and $I_L = 3.7\sim 4.7 \text{ mA}_{\text{rms}}$ until one of the following events occurs:

- When the brightness becomes or lower than 50% of its original value.
- When the effective ignition length becomes lower than 80% of its original value. (Effective ignition length is defined as an area that has less than 70% brightness compared to the brightness in the center point.)

Note (5) The waveform of the voltage output of inverter must be area-symmetric and the design of the inverter must have specifications for the modularized lamp. The performance of the Backlight, such as lifetime or brightness, is greatly influenced by the characteristics of the DC-AC inverter for the lamp. All the parameters of an inverter should be carefully designed to avoid producing too much current leakage from high voltage output of the inverter. When designing or ordering the inverter please make sure that a poor lighting caused by the mismatch of the Backlight and the inverter (miss-lighting, flicker, etc.) never occurs. If the above situation is confirmed, the module should be operated in the same manners when it is installed in your instrument.

The output of the inverter must have symmetrical (negative and positive) voltage waveform and symmetrical current waveform. (Unsymmetrical ratio is less than 10%) Please do not use the inverter, which has unsymmetrical voltage and unsymmetrical current and spike wave. Lamp frequency may produce interference with horizontal synchronous frequency and as a result this may cause beat on the display. Therefore lamp frequency shall be as away possible from the horizontal synchronous frequency and from its harmonics in order to prevent interference.

Requirements for a system inverter design, which is intended to have a better display performance, a better power efficiency and a more reliable lamp. It shall help increase the lamp lifetime and reduce its leakage current.

- The asymmetry rate of the inverter waveform should be 10% below;
- The distortion rate of the waveform should be within $\sqrt{2} \pm 10\%$;
- The ideal sine wave form shall be symmetric in positive and negative polarities.

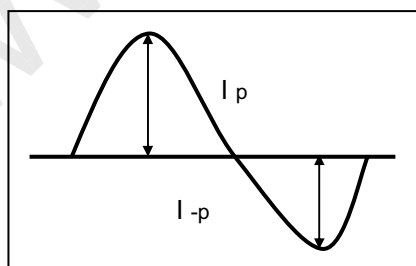

* Asymmetry rate:

$$\frac{|I_p - I_{-p}|}{I_{\text{rms}}} * 100\%$$

* Distortion rate

$$I_p \text{ (or } I_{-p}) / I_{\text{rms}}$$

4.3.4 INVERTER ELECTRICAL CHARACTERISTIC

Item	Symbol	Description	Min.	Typ.	Max.	Unit
1	V _{in}	Input voltage	11.4	12	12.6	V
2	I _{in}	Input current (@Vin=12V)	---	3.4	---	A
3	P _{in}	Input power	---	40.8	---	W
4	BLON	Inverter On/Off control: OFF	0	---	0.8	V
		Inverter On/Off control: ON	2	---	5	V
5	VDIM	Output current control	0	---	3	V
		VDIM: 0V, maximum brightness VDIM: 3V, minimum brightness				
6	F _b	Burst Mode Frequency	150	160	170	Hz
7	Freq.	Operating frequency	52	55	58	KHz
8	I _{out}	Output current, VDIM=0V (high side)	3.7	4.2	4.7	mA

4.3.5 INVERTER INPUT SIGNAL

Pin No.	Symbol	Description
1	Vin	Input voltage
2	Vin	Input voltage
3	Vin	Input voltage
4	Vin	Input voltage
5	Vin	Input voltage
6	Gnd	Ground
7	Gnd	Ground
8	Gnd	Ground
9	Gnd	Ground
10	Gnd	Ground
11	VDIM	Brightness control (0~3V)
12	BLON	Inverter On/Off control (5.0/0V)

Note (1) Connector Part No.: B12B-PH-SM4-TB (JST) or equivalent

Note (2) User's connector Part No.: → PHR-12 (JST)

The following chart is the VDIM vs. Dimming Range for your reference.

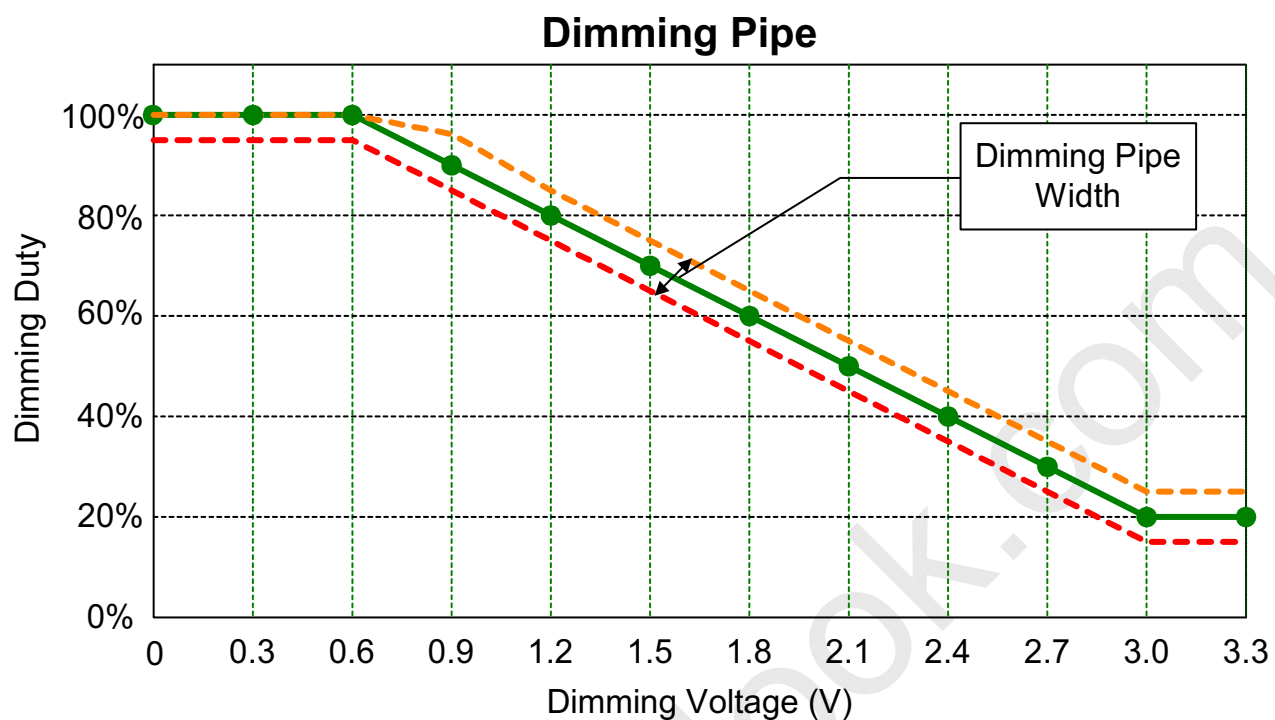

4.4 LVDS INPUT SIGNAL SPECIFICATIONS

4.4.1 LVDS DATA MAPPING TABLE

VESA MODE

LVDS_SEL = Ground or Open								
LVDS Channel O0	LVDS output	D7	D6	D4	D3	D2	D1	D0
	Data order	OG0	OR5	OR4	OR3	OR2	OR1	OR0
LVDS Channel O1	LVDS output	D18	D15	D14	D13	D12	D9	D8
	Data order	OB1	OB0	OG5	OG4	OG3	OG2	OG1
LVDS Channel O2	LVDS output	D26	D25	D24	D22	D21	D20	D19
	Data order	DE	NA	NA	OB5	OB4	OB3	OB2
LVDS Channel O3	LVDS output	D23	D17	D16	D11	D10	D5	D27
	Data order	NA	OB7	OB6	OG7	OG6	OR7	OR6
LVDS Channel E0	LVDS output	D7	D6	D4	D3	D2	D1	D0
	Data order	EG0	ER5	ER4	ER3	ER2	ER1	ER0
LVDS Channel E1	LVDS output	D18	D15	D14	D13	D12	D9	D8
	Data order	EB1	EB0	EG5	EG4	EG3	EG2	EG1
LVDS Channel E2	LVDS output	D26	D25	D24	D22	D21	D20	D19
	Data order	DE	NA	NA	EB5	EB4	EB3	EB2
LVDS Channel E3	LVDS output	D23	D17	D16	D11	D10	D5	D27
	Data order	NA	EB7	EB6	EG7	EG6	ER7	ER6

JEITA MODE

LVDS_SEL = 3.3V								
LVDS Channel O0	LVDS output	D7	D6	D4	D3	D2	D1	D0
	Data order	OG2	OR7	OR6	OR5	OR4	OR3	OR2
LVDS Channel O1	LVDS output	D18	D15	D14	D13	D12	D9	D8
	Data order	OB3	OB2	OG7	OG6	OG5	OG4	OG3
LVDS Channel O2	LVDS output	D26	D25	D24	D22	D21	D20	D19
	Data order	DE	NA	NA	OB7	OB6	OB5	OB4
LVDS Channel O3	LVDS output	D23	D17	D16	D11	D10	D5	D27
	Data order	NA	OB1	OB0	OG1	OG0	OR1	OR0
LVDS Channel E0	LVDS output	D7	D6	D4	D3	D2	D1	D0
	Data order	EG2	ER7	ER6	ER5	ER4	ER3	ER2
LVDS Channel E1	LVDS output	D18	D15	D14	D13	D12	D9	D8
	Data order	EB3	EB2	EG7	EG6	EG5	EG4	EG3
LVDS Channel E2	LVDS output	D26	D25	D24	D22	D21	D20	D19
	Data order	DE	NA	NA	EB7	EB6	EB5	EB4
LVDS Channel E3	LVDS output	D23	D17	D16	D11	D10	D5	D27
	Data order	NA	EB1	EB0	EG1	EG0	ER1	ER0

4.4.2 COLOR DATA INPUT ASSIGNMENT

The brightness of each primary color (red, green and blue) is based on the 8-bit gray scale data input for the color. The higher the binary input, the brighter the color. The table below provides the assignment of color versus data input.

Color		Data Signal																							
		Red								Green								Blue							
		R7	R6	R5	R4	R3	R2	R1	R0	G7	G6	G5	G4	G3	G2	G1	G0	B7	B6	B5	B4	B3	B2	B1	B0
Basic Colors	Black	0	0	0	0	0	0	0	0	0	0	0	0	0	0	0	0	0	0	0	0	0	0	0	0
	Red	1	1	1	1	1	1	1	1	0	0	0	0	0	0	0	0	0	0	0	0	0	0	0	0
	Green	0	0	0	0	0	0	0	0	1	1	1	1	1	1	1	0	0	0	0	0	0	0	0	0
	Blue	0	0	0	0	0	0	0	0	0	0	0	0	0	0	0	1	1	1	1	1	1	1	1	1
	Cyan	0	0	0	0	0	0	0	0	1	1	1	1	1	1	1	1	1	1	1	1	1	1	1	1
	Magenta	1	1	1	1	1	1	1	1	0	0	0	0	0	0	0	0	1	1	1	1	1	1	1	1
	Yellow	1	1	1	1	1	1	1	1	1	1	1	1	1	1	1	0	0	0	0	0	0	0	0	0
	White	1	1	1	1	1	1	1	1	1	1	1	1	1	1	1	1	1	1	1	1	1	1	1	1
Gray Scale Of Red	Red(0) / Dark	0	0	0	0	0	0	0	0	0	0	0	0	0	0	0	0	0	0	0	0	0	0	0	
	Red(1)	0	0	0	0	0	0	1	0	0	0	0	0	0	0	0	0	0	0	0	0	0	0	0	
	Red(2)	0	0	0	0	0	0	1	0	0	0	0	0	0	0	0	0	0	0	0	0	0	0	0	
	⋮	⋮	⋮	⋮	⋮	⋮	⋮	⋮	⋮	⋮	⋮	⋮	⋮	⋮	⋮	⋮	⋮	⋮	⋮	⋮	⋮	⋮	⋮	⋮	
	⋮	⋮	⋮	⋮	⋮	⋮	⋮	⋮	⋮	⋮	⋮	⋮	⋮	⋮	⋮	⋮	⋮	⋮	⋮	⋮	⋮	⋮	⋮	⋮	
	Red(253)	1	1	1	1	1	1	0	1	0	0	0	0	0	0	0	0	0	0	0	0	0	0	0	0
	Red(254)	1	1	1	1	1	1	1	0	0	0	0	0	0	0	0	0	0	0	0	0	0	0	0	0
	Red(255)	1	1	1	1	1	1	1	1	0	0	0	0	0	0	0	0	0	0	0	0	0	0	0	0
Gray Scale Of Green	Green(0)/Dark	0	0	0	0	0	0	0	0	0	0	0	0	0	0	0	0	0	0	0	0	0	0	0	
	Green(1)	0	0	0	0	0	0	0	0	0	0	0	0	0	0	1	0	0	0	0	0	0	0	0	
	Green(2)	0	0	0	0	0	0	0	0	0	0	0	0	0	1	0	0	0	0	0	0	0	0	0	
	⋮	⋮	⋮	⋮	⋮	⋮	⋮	⋮	⋮	⋮	⋮	⋮	⋮	⋮	⋮	⋮	⋮	⋮	⋮	⋮	⋮	⋮	⋮	⋮	
	⋮	⋮	⋮	⋮	⋮	⋮	⋮	⋮	⋮	⋮	⋮	⋮	⋮	⋮	⋮	⋮	⋮	⋮	⋮	⋮	⋮	⋮	⋮	⋮	
	Green(253)	0	0	0	0	0	0	0	0	1	1	1	1	1	1	0	1	0	0	0	0	0	0	0	0
	Green(254)	0	0	0	0	0	0	0	0	1	1	1	1	1	1	1	0	0	0	0	0	0	0	0	
	Green(255)	0	0	0	0	0	0	0	0	1	1	1	1	1	1	1	1	0	0	0	0	0	0	0	
Gray Scale Of Blue	Blue(0) / Dark	0	0	0	0	0	0	0	0	0	0	0	0	0	0	0	0	0	0	0	0	0	0	0	
	Blue(1)	0	0	0	0	0	0	0	0	0	0	0	0	0	0	0	0	0	0	0	0	0	0	1	
	Blue(2)	0	0	0	0	0	0	0	0	0	0	0	0	0	0	0	0	0	0	0	0	0	0	1	
	⋮	⋮	⋮	⋮	⋮	⋮	⋮	⋮	⋮	⋮	⋮	⋮	⋮	⋮	⋮	⋮	⋮	⋮	⋮	⋮	⋮	⋮	⋮	⋮	
	⋮	⋮	⋮	⋮	⋮	⋮	⋮	⋮	⋮	⋮	⋮	⋮	⋮	⋮	⋮	⋮	⋮	⋮	⋮	⋮	⋮	⋮	⋮	⋮	
	Blue(253)	0	0	0	0	0	0	0	0	0	0	0	0	0	0	0	1	1	1	1	1	1	1	0	
	Blue(254)	0	0	0	0	0	0	0	0	0	0	0	0	0	0	0	1	1	1	1	1	1	1	0	
	Blue(255)	0	0	0	0	0	0	0	0	0	0	0	0	0	0	0	1	1	1	1	1	1	1	1	

Note (1) 0: Low Level Voltage, 1: High Level Voltage

4.5 DISPLAY TIMING SPECIFICATIONS

The input signal timing specifications are shown as the following table and timing diagram.

Signal	Item	Symbol	Min.	Typ.	Max.	Unit	Note
LVDS Clock	Frequency	F_c	45.74	54	75.03	MHz	-
	Period	T_c	13.33	18.5	21.8	ns	-
	Input cycle to cycle jitter	T_{rd}	---	---	250	ns	(1)
	Input Clock to data skew	TLVCCS			350	ps	(2)
	Spread spectrum modulation range	F_{ckin_mod}	---	---	$1.02 * F_c$	MHz	(3)
	Spread spectrum modulation frequency	F_{SSM}	---	---	200	KHz	
Vertical Display Term	Frame Rate	F_r	56	60	75	Hz	$T_v = T_{vd} + T_{vb}$
	Total	T_v	1034	1066	1124	Th	-
	Active Display	T_{vd}	1024	1024	1024	Th	-
	Blank	T_{vb}	$T_v - T_{vd}$	42	$T_v - T_{vd}$	Th	-
Horizontal Display Term	Total	T_h	790	844	890	Tc	$T_h = T_{hd} + T_{hb}$
	Active Display	T_{hd}	640	640	640	Tc	-
	Blank	T_{hb}	$T_h - T_{hd}$	204	$T_h - T_{hd}$	Tc	-

Note: Because this module is operated by DE only mode, H_{sync} and V_{sync} input signals should be set to low logic level or ground. Otherwise, this module would operate abnormally.

INPUT SIGNAL TIMING DIAGRAM

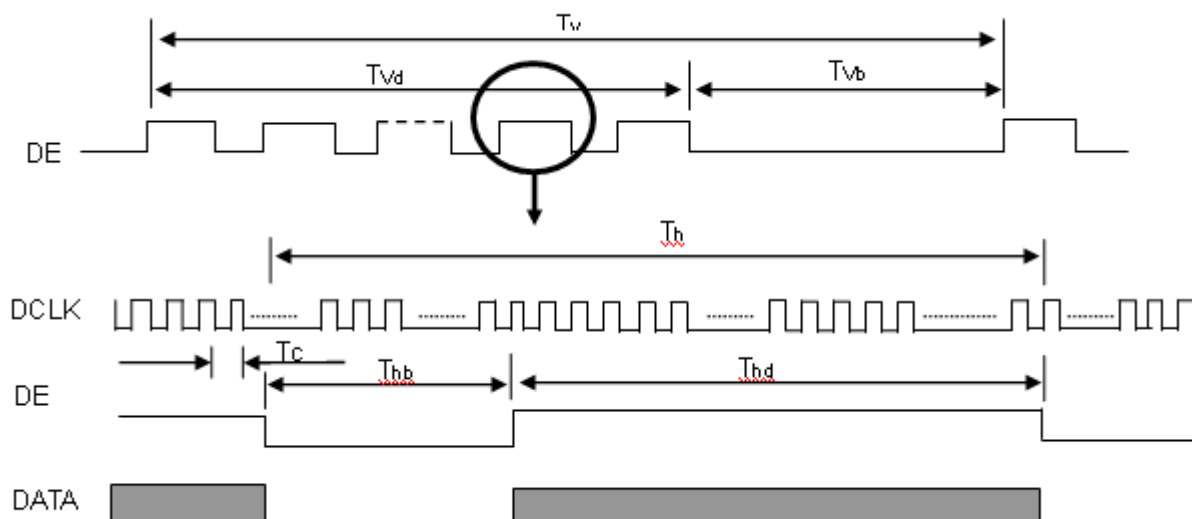

Note (1) The input clock cycle-to-cycle jitter is defined as below figures. $Trcl = |T_1 - T_1|$

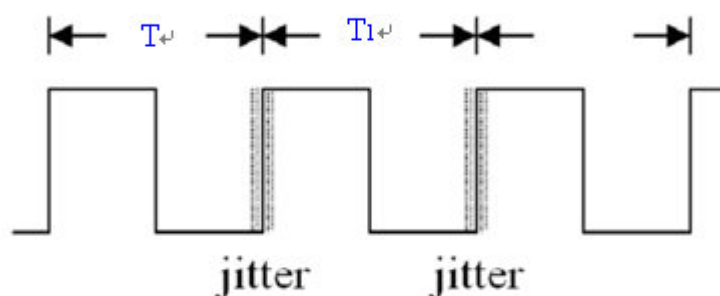

Note (2) Input Clock to data skew is defined as below figures.

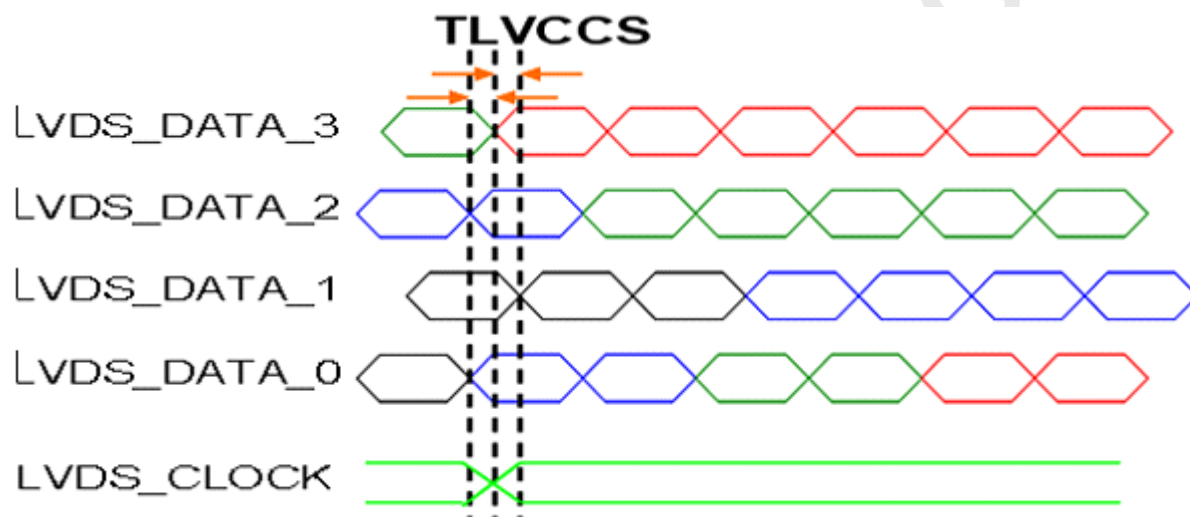

Note (3) The SSCG (Spread spectrum clock generator) is defined as below figures.

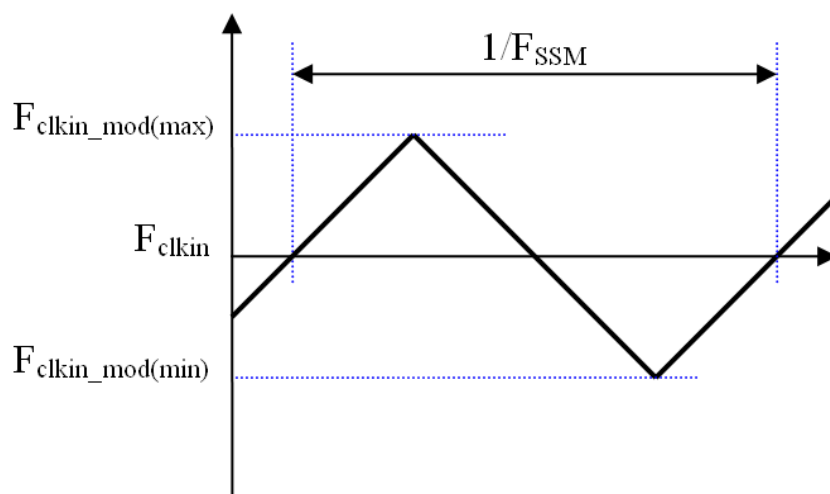

4.6 POWER ON/OFF SEQUENCE

The power sequence specifications are shown as the following table and diagram.

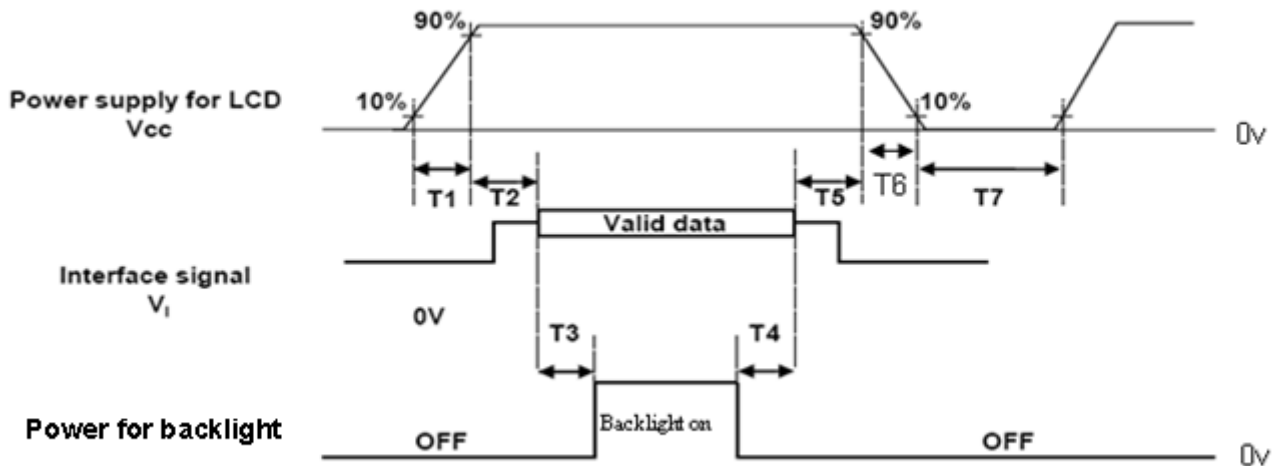

Timing Specifications:

Parameters	Values			Units
	Min	Typ.	Max	
T1	0.5	-	10	ms
T2	0	-	50	ms
T3	450	-	-	ms
T4	90	-	-	ms
T5	0	-	50	ms
T6	5	-	100	ms
T7	500	-	-	ms

Note.

- (1) The supply voltage of the external system for the module input should be the same as the definition of Vcc.
- (2) Apply the lamp voltage within the LCD operation range. When the backlight turns on before the LCD operation of the LCD turns off before the backlight turns off, the display may momentarily become abnormal screen.
- (3) In case of V_{CC} = off level, please keep the level of input signals on the low or keep a high impedance.
- (4) T7 should be measured after the module has been fully discharged between power of and on period.
- (5) Interface signal shall not be kept at high impedance when the power is on.
- (6) It is not guaranteed that products are damaged which is caused by not following the Power Sequence.

- (7) It is suggested that Vcc falling time follows T6 specification; else slight noise is likely to occur when LCD is turned off (even backlight is already off).

www.panelook.com

5. OPTICAL CHARACTERISTICS

5.1 OPTICAL SPECIFICATIONS

The relative measurement methods of optical characteristics are shown in 5.1. The following items should be measured under the test conditions described in 5.1 and stable environment shown in Note (5).

Item	Symbol	Condition	Min.	Typ.	Max.	Unit	Note
White Balance	W_x	$\theta_x=0^\circ, \theta_y=0^\circ$ CS-2000	Typ - 0.03	0.294	Typ+ 0.03		(1), (5)
	W_y			0.309			
Center Luminance of White	L_C		1000	1300	---	cd/m ²	(4), (5)
Contrast Ratio	CR		800	1000	---	-	(2), (5)
Response Time	T_R	$\theta_x=0^\circ, \theta_y=0^\circ$	---	15	25	ms	(3)
	T_F		---	5	15	ms	
White Variation(adjacent)	δW_a	$\theta_x=0^\circ, \theta_y=0^\circ$ USB2000	90	---	---	-	(5), (6)
White Variation(total)	δW_t	$\theta_x=0^\circ, \theta_y=0^\circ$ USB2000	70	---	---	-	(5), (6)
Viewing Angle	In all azimuth	CR \geq 20 USB2000	80	85	-	Deg.	(1), (5)

Note (1) Definition of Viewing Angle (θ_x, θ_y):

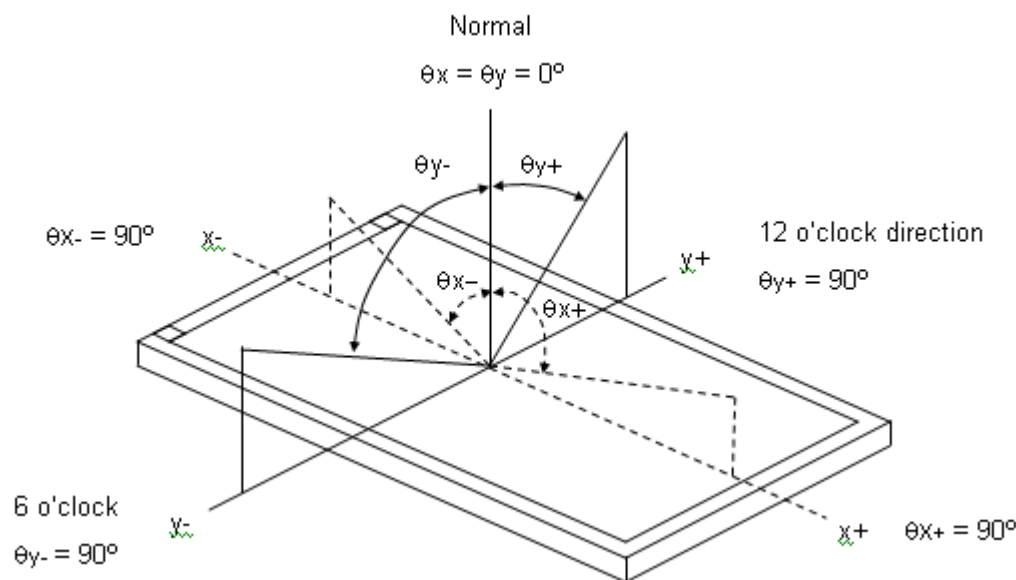

Note (2) Definition of Contrast Ratio (CR):

The contrast ratio can be calculated by the following expression.

$$\text{Contrast Ratio (CR)} = L_{255} / L_0$$

L255: Luminance of gray level 255

L 0: Luminance of gray level 0

$$\text{CR} = \text{CR} (5)$$

CR (X) is corresponding to the Contrast Ratio of the point X at Figure in Note (4).

Note (3) Definition of Response Time (T_R , T_F):

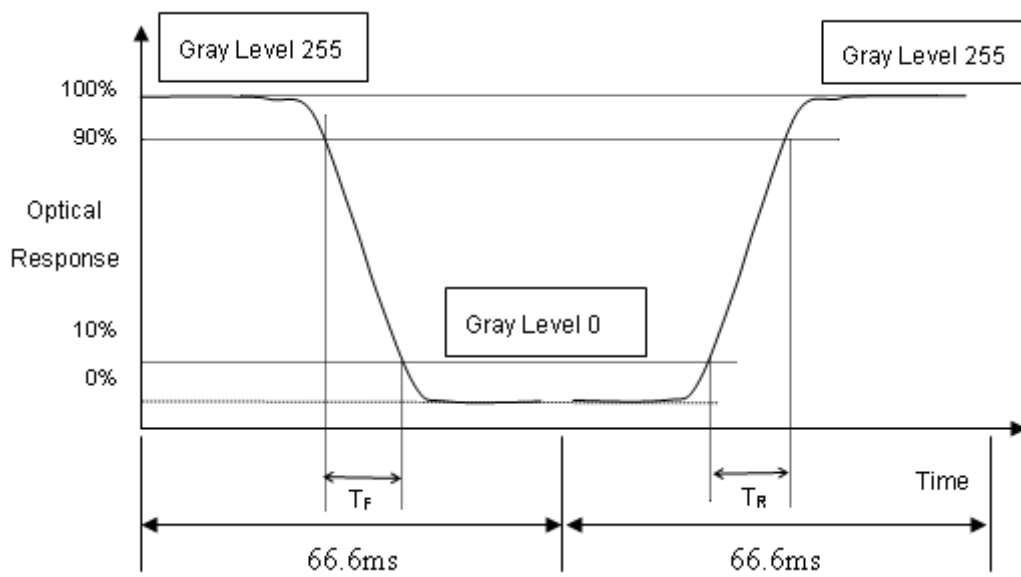

Note (4) Definition of Luminance of White (L_C):

Measure the luminance of gray level 255 at center point

$$L_C = L (5)$$

L (x) is corresponding to the luminance of the point X at the following figure.

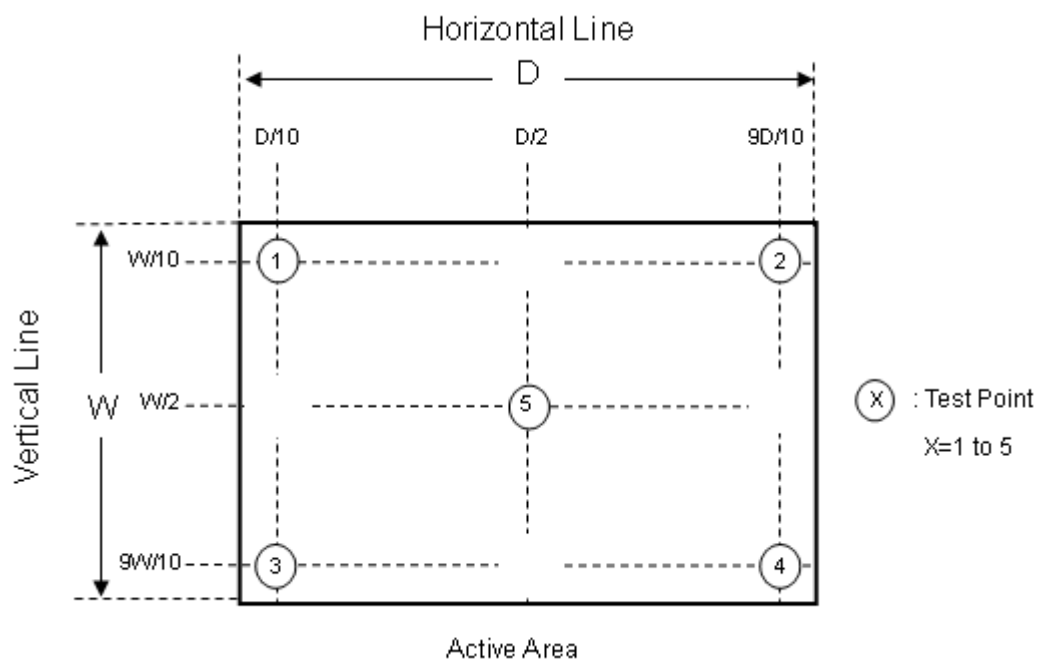

Note (5) Measurement Setup:

The LCD module should be stabilized at given temperature for 60 minutes to avoid abrupt temperature change during measuring. In order to stabilize the luminance, the measurement should be executed after lighting Backlight for 60 minutes in a windless room.

Unless otherwise specified, the ambient conditions are as following.

Ambient Temperature: 25 ± 2 (degreeC)

Ambient Humidity: 25 ~ 85 (%)

Atmospheric Pressure: 86.0 ~ 104.0 (kPa)

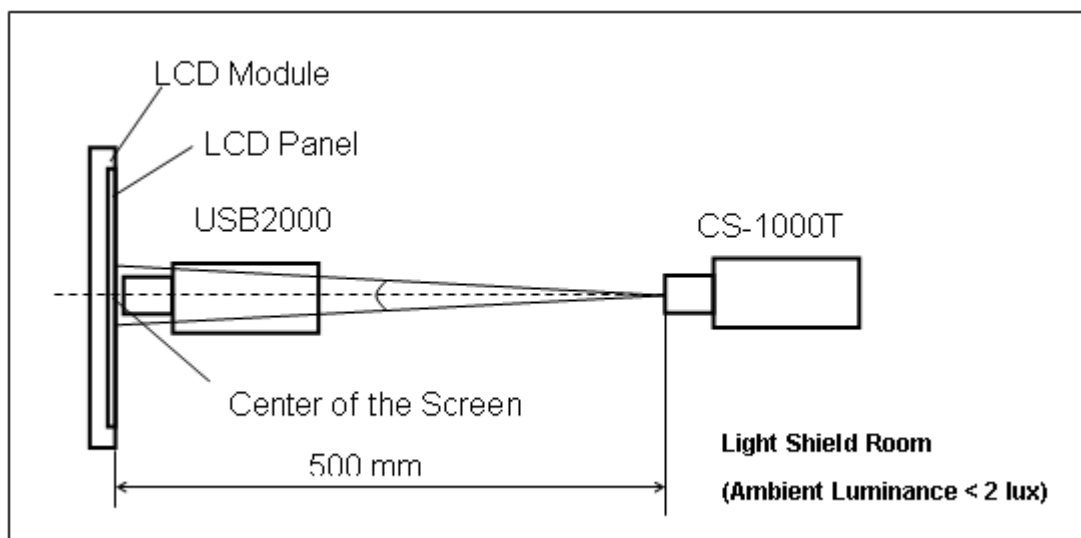

Note (6) There is the Uniformity Measurement below:

'L_{bright}' represents the Luminance of the point that is brighter than the other point to be compared.

'L_{dark}' represents the Luminance of the point that is darker than the other point to be compared.

Measuring points are shown in the following Fig.

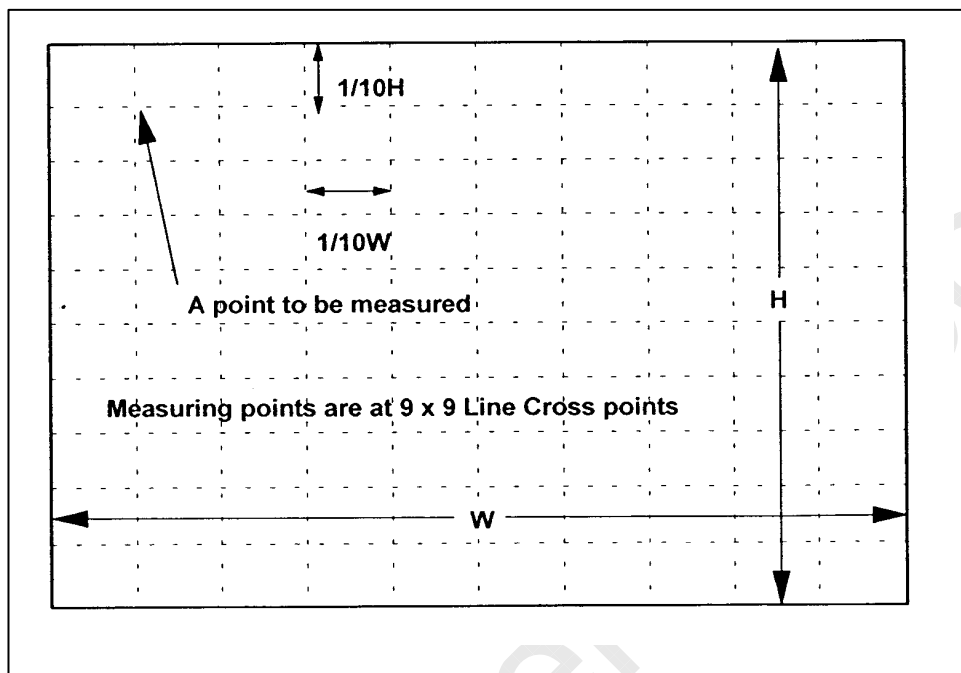

When the backlight is on with all pixels in the white (maximum gray) level, the luminance uniformity is defined as follows;

Where:

L_{bright}: The luminance of the brightness part of the area

L_{dark}: The luminance of the darkest part of the area

1. Adjacent Area

$$\text{Luminance Uniformity} = \frac{L_{\text{dark}}}{L_{\text{bright}}} \geq 0.90$$

over a circular area of 10mm diameter placed anywhere on the screen.

2. Screen Total

$$\text{Luminance Uniformity} = \frac{L_{\text{dark}}}{L_{\text{bright}}} \geq 0.70$$

over the entire screen.

6. RELIABILITY TEST ITEM

Items	Required Condition	Note
Temperature Humidity Bias (THB)	Ta= 50°C , 80%RH, 240hours	
High Temperature Operation (HTO)	Ta= 55°C. , 240hours	
Low Temperature Operation (LTO)	Ta= 0°C , 240hours	
High Temperature Storage (HTS)	Ta= 60°C , 240hours	
Low Temperature Storage (LTS)	Ta= -20°C , 240hours	
Vibration Test (Non-operation)	Acceleration: 1.5 G _{rms} Wave: Half-sine Frequency: 10 - 300 Hz Sweep: 30 Minutes each Axis (X, Y, Z)	
Shock Test (Non-operation)	Acceleration: 50 G Wave: Half-sine Active Time: 11 ms Direction : ± X, ± Y, ± Z.(one time for each Axis)	
Thermal Shock Test (TST)	-20°C/30min , 60°C / 30min , 100 cycles	
ESD (Electro Static Discharge)	Contact Discharge: ± 8KV, 150pF(330Ω) Air Discharge: ± 15KV, 150pF(330Ω)	

Note (1) criteria: Normal display image with no obvious non-uniformity and no line defect.

Note (2) Evaluation should be tested after storage at room temperature for more than two hour

Note (3) At testing Vibration and Shock, the fixture in holding the module has to be hard and rigid enough so that the module would not be twisted or bent by the fixture.

The fixing condition is shown as below:

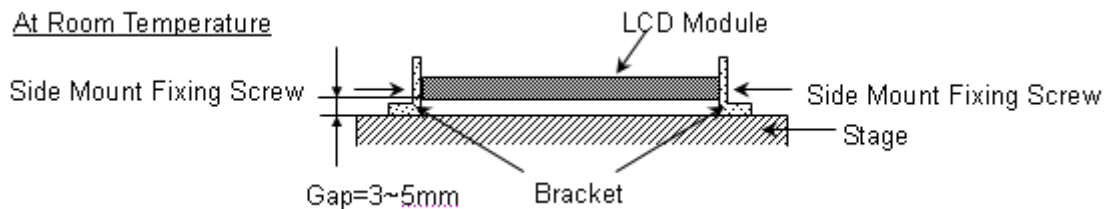

7. PACKING

7.1 PACKING SPECIFICATIONS

- (1) 5 LCD modules / 1 Box
- (2) Box dimensions: 485(L) X 365(W) X 430(H) mm
- (3) Weight: approximately: 11.75kg (5 modules per box)

7.2 PACKING METHOD

- (1) Carton Packing should have no failure in the following reliability test items.

Test Item	Test Conditions	Note
Vibration	ISTA STANDARD Random, Frequency Range: 1 – 200 Hz Top & Bottom: 30 minutes (+Z), 10 min (-Z), Right & Left: 10 minutes (X) Back & Forth 10 minutes (Y)	Non Operation
Dropping Test	1 Corner , 3 Edge, 6 Face, 61cm	Non Operation

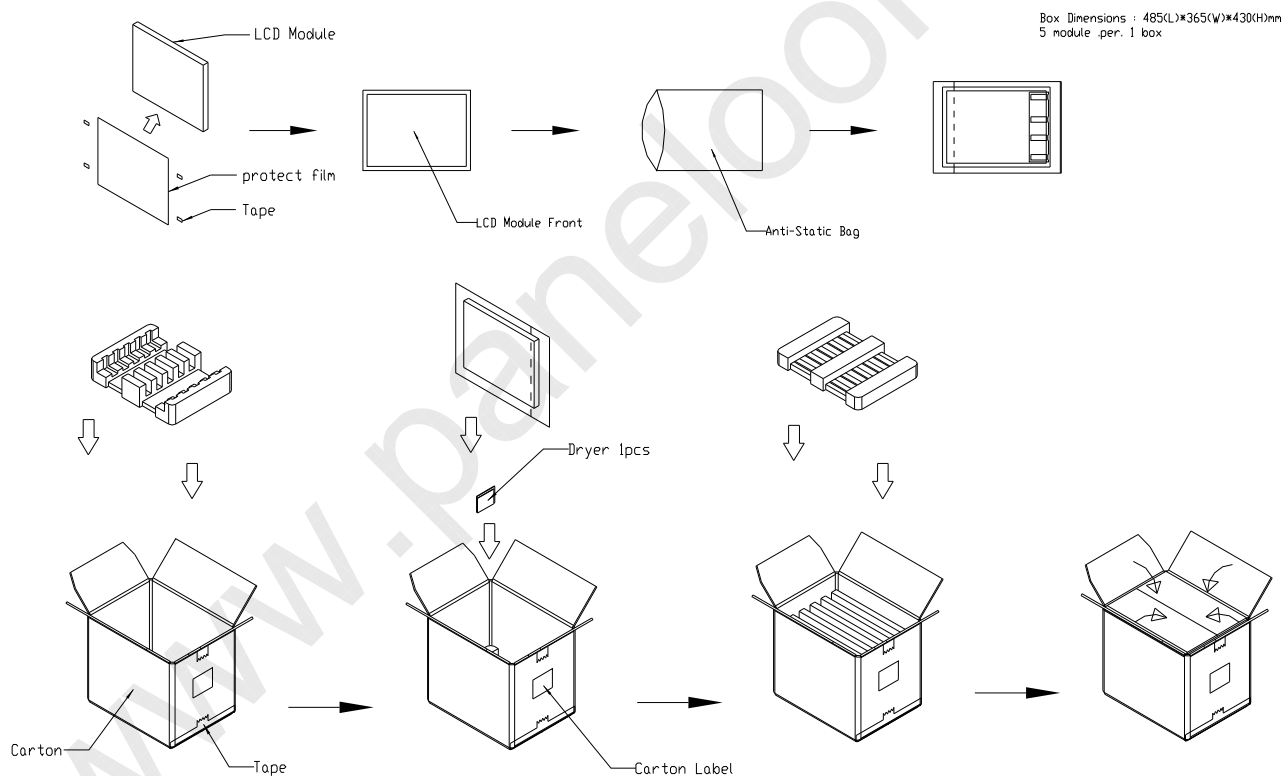
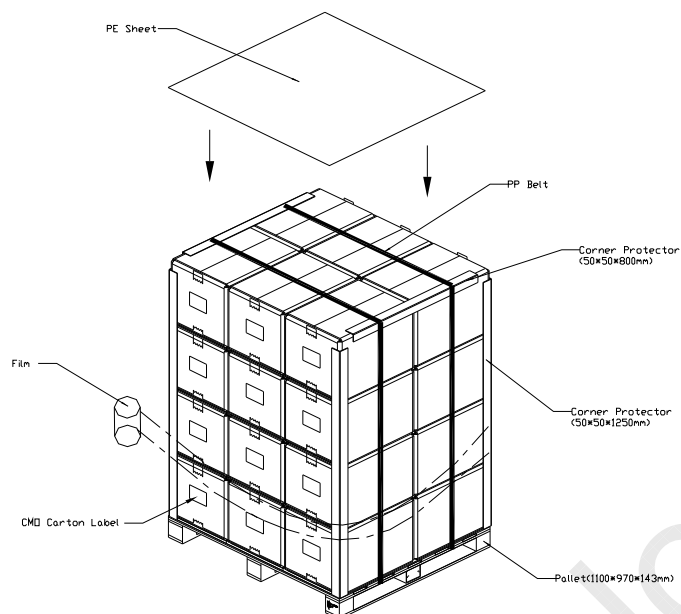

Figure. 7-1 Packing method

7.3 PALLET

For ocean shipping

Sea and land transportation



For air transport

Air transportation

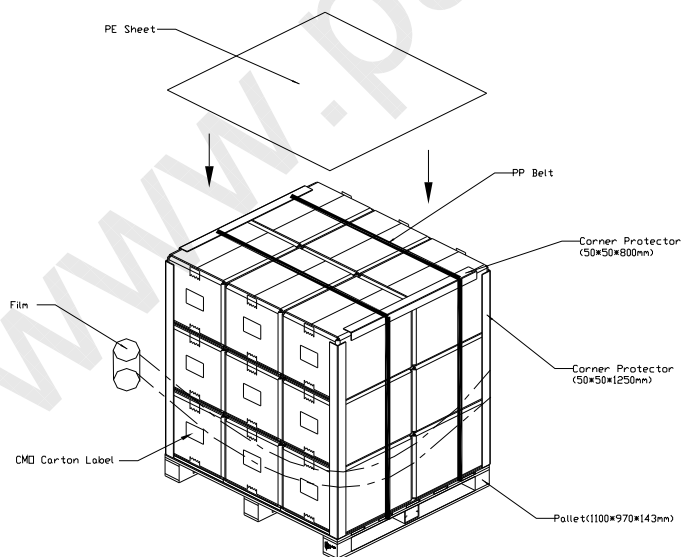
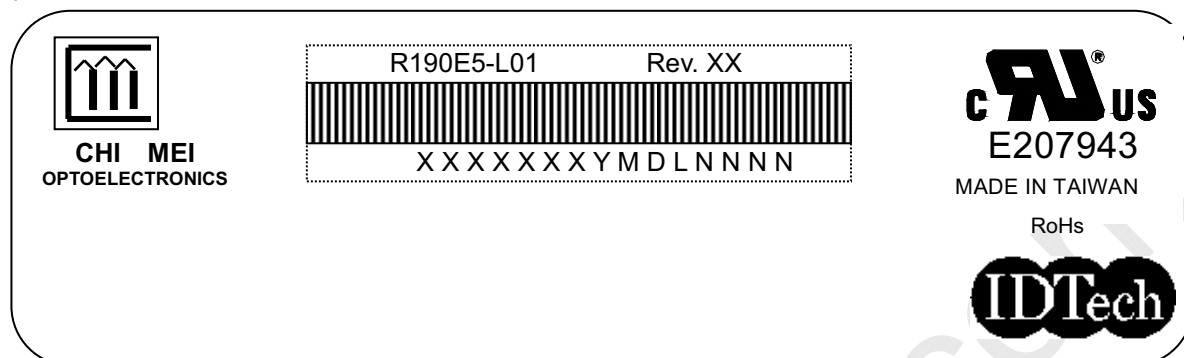

Figure. 7-2 Packing method

8. CMI MODULE LABEL

The barcode nameplate is pasted on each module as illustration, and its definitions are as following explanation.



(a) Model Name: R190E5-L01

(b) Revision: Rev. XX, for example: A0, A1... B1, B2... or C1, C2...etc.

(c) CMI barcode definition:

Serial ID: XX-XX-X-XX-YMD-L-NNNN

Code	Meaning	Description
XX	CMI internal use	-
XX	Revision	Cover all the change
X	CMI internal use	-
XX	CMI internal use	-
YMD	Year, month, day	Year: 0~9, 2001=1, 2002=2, 2003=3...2010=0, 2011=1, 2012=2... Month: 1~12=1, 2, 3, ~, 9, A, B, C Day: 1~31=1, 2, 3, ~, 9, A, B, C, ~, W, X, Y, exclude I, O, and U.
L	Product line #	Line 1=1, Line 2=2, Line 3=3, ...
NNNN	Serial number	Manufacturing sequence of product

9. PRECAUTIONS

9.1 ASSEMBLY AND HANDLING PRECAUTIONS

- (1) Do not apply rough force such as bending or twisting to the module during assembly.
- (2) To assemble or install module into user's system can be only in clean working areas. The dust and oil may cause electrical short or worsen the polarizer.
- (3) It's not permitted to have pressure or impulse on the module because the LCD panel and Backlight will be damaged.
- (4) Always follow the correct power sequence when LCD module is connecting and operating. This can prevent damage to the CMOS LSI chips during latch-up.
- (5) Do not pull the I/F connector in or out while the module is operating.
- (6) Do not disassemble the module.
- (7) Use a soft dry cloth without chemicals for cleaning, because the surface of polarizer is very soft and easily scratched.
- (8) It is dangerous that moisture come into or contacted the LCD module, because moisture may damage LCD module when it is operating.
- (9) High temperature or humidity may reduce the performance of module. Please store LCD module within the specified storage conditions.
- (10) When ambient temperature is lower than 10°C may reduce the display quality. For example, the response time will become slowly.

9.2 STORAGE PRECAUTIONS

- (1) Do not leave the module in high temperature, and high humidity for a long time. It is highly recommended to store the module with temperature from 0°C to 35°C and relative humidity of less than 70%
- (2) Do not store the TFT – LCD module in direct sunlight
- (3) The module should be stored in dark place. It is prohibited to apply sunlight or fluorescent light in storing

9.3 OPERATION PRECAUTIONS

- (1) The LCD product should be operated under normal condition.
Normal condition is defined as below :
Temperature : 20±15°C
Humidity: 65±20%
Display pattern: continually changing pattern (Not stationary)
- (2) If the product will be used in extreme conditions such as high temperature, high humidity, high altitude ,display pattern or operation time etc...It is strongly recommended to contact CMO for application engineering advice . Otherwise, Its reliability and function may not be guaranteed.

9.4 SAFETY PRECAUTIONS

- (1) If the liquid crystal material leaks from the panel, it should be kept away from the eyes or mouth. In case of contact with hands, skin or clothes, it has to be washed away thoroughly with soap.
- (2) After the module's end of life, it is not harmful in case of normal operation and storage.

9.5 SAFETY STANDARDS

The LCD module should be certified with safety regulations as follows:

- (1) UL60950-1 or updated standard.
- (2) IEC60950-1 or updated standard.

9.6 OTHER

When fixed patterns are displayed for a long time, remnant image is likely to occur.

