



MODEL NO. : TM035WDH01-00

ISSUED DATE: 2012-8-13

VERSION : Ver 2.0

- Preliminary Specification
 Final Product Specification

Customer : _____

Approved by	Notes

SHANGHAI TIANMA Confirmed :

Prepared by	Checked by	Approved by
Longping.Deng	Jinquan.Liu	Ruiyuan.Zhou

This technical specification is subjected to change without notice

The information contained herein is the exclusive property of SHANGHAI TIANMA MICRO-ELECTRONICS Corporation, and shall not be distributed, reproduced, or disclosed in whole or in part without prior written permission of SHANGHAI TIANMA MICRO-ELECTRONICS Corporation.



Table of Contents

Coversheet.....	1
Table of Contents.....	2
Record of Revision.....	3
1 General Specifications.....	4
2 Input/Output Terminals.....	5
3 Absolute Maximum Ratings.....	7
4 Electrical Characteristics.....	8
5 Timing Chart.....	10
6 Optical Characteristics.....	17
7 Environmental / Reliability Test.....	20
8 Mechanical Drawing.....	22
9 Packing Drawing.....	23
10 Precautions For Use of LCD Modules.....	24

The information contained herein is the exclusive property of SHANGHAI TIANMA MICRO-ELECTRONICS Corporation, and shall not be distributed, reproduced, or disclosed in whole or in part without prior written permission of SHANGHAI TIANMA MICRO-ELECTRONICS Corporation.



Record of Revision

Rev	Issued Date	Description	Editor
1.0	2012-6-18	Preliminary Specification Release	Longping.Deng
2.0	2012-08-13	Final Specification Release	Longping.Deng

The information contained herein is the exclusive property of SHANGHAI TIANMA MICRO-ELECTRONICS Corporation, and shall not be distributed, reproduced, or disclosed in whole or in part without prior written permission of SHANGHAI TIANMA MICRO-ELECTRONICS Corporation.



1 General Specifications

	Feature	Spec
Display Spec.	Size	3.5 inch
	Resolution	480(RGB) × 640
	Interface	RGB18 bit +SPI
	Color Depth	262K
	Technology Type	a-si TFT
	Pixel Pitch (mm)	0.111x0.111
	Pixel Configuration	R.G.B. Vertical Stripe
	Display Mode	TM,NW
	Surface Treatment(Up Polarizer)	AG
	Viewing Direction	9 o' clock
	Gray Scale Inversion Direction	3 o' clock
Mechanical Characteristics	LCM (W x H x D) (mm)	64.00*85.00*3.0
	Active Area(mm)	53.28*71.04
	With/Without TSP	Without TSP
	Weight (g)	34
	LED Numbers	6 LED

The information contained herein is the exclusive property of SHANGHAI TIANMA MICRO-ELECTRONICS Corporation, and shall not be distributed, reproduced, or disclosed in whole or in part without prior written permission of SHANGHAI TIANMA MICRO-ELECTRONICS Corporation.



2 Input/Output Terminals

2.1 TFT LCD Panel

Pin	Symbol	I/O	Description	Remark
1	GND	P	Ground	
2	YU	/	Touch Panel Upper side(No connection)	
3	XR	/	Touch Panel Right side(No connection)	
4	YD	/	Touch Panel Lower side(No connection)	
5	XL	/	Touch Panel Left side(No connection)	
6	GND	P	Ground	
7	NC	/	No connection	
8	NC	/		
9	GND	P	Ground	
10	NC	/	No connection	
11	NC	/		
12	NC	/		
13	NC	/		
14	NC	/		
15	GND	P	Ground	
16	NC	/	No connection	
17	RESET	I	Reset pin to Initial the IC, when RESET="L", reset enable	
18	NC	/	No connection	
19	NC	/		
20	VDD	P	Power supply (+3.3V)	
21	GND	P	Ground	
22~27	B00~B05	I	6bits Blue Data	
28	GND	P	Ground	
29~34	G00~G05	I	6bits Green Data	
35	GND	P	Ground	
36~41	R00~R05	I	6bits Red Data	
42	GND	P	Ground	
43	VDD	P	Power supply (+3.3V)	

The information contained herein is the exclusive property of SHANGHAI TIANMA MICRO-ELECTRONICS Corporation, and shall not be distributed, reproduced, or disclosed in whole or in part without prior written permission of SHANGHAI TIANMA MICRO-ELECTRONICS Corporation.



TIANMA MICRO-ELECTRONICS

TM035WDH01-00 V2.0

44	NC	/	No connection	
45	GND	P	Ground	
46	MCLK	I	No connection	
47	GND	P	Ground	
48	ENAB	I	Data Enable for RGB interface operation	
49	GND	P	Ground	
50	CS	I	Chip select	
51	SDA/SDO	I/O	Serial Data signal	
52	NC	/	No connection	
53	SCL	I	Serial clock signal	
54	VS	I	Vertical Sync Signal	
55	HS	I	Horizontal Sync Signal	
56	NC	/	No connection	
57	NC	/	No connection	
58	LED-	P	LED light cathode	
59	LED+	P	LED light anode (+19.2V)	
60	GND	P	Ground	

Note1: I/O definition: I----Input O---Output P----Power/Ground

Note2: Internal connection, PSWAP=1, DSWAP=00; Please refer to NT35516's spec.

The information contained herein is the exclusive property of SHANGHAI TIANMA MICRO-ELECTRONICS Corporation, and shall not be distributed, reproduced, or disclosed in whole or in part without prior written permission of SHANGHAI TIANMA MICRO-ELECTRONICS Corporation.



3 Absolute Maximum Ratings

3.1 Driving TFT LCD Panel

GND=0V, Ta = 25°C

Item	Symbol	Min	Max	Unit	Remark
Power Voltage	VDD	-0.3	4.6	V	
Input signal Voltage	Vin	GND	VDD	V	
Operating Temperature	TOPR	-20	60	°C	
Storage Temperature	TSTG	-30	70	°C	

The information contained herein is the exclusive property of SHANGHAI TIANMA MICRO-ELECTRONICS Corporation, and shall not be distributed, reproduced, or disclosed in whole or in part without prior written permission of SHANGHAI TIANMA MICRO-ELECTRONICS Corporation.



4 Electrical Characteristics

4.1 Driving TFT LCD Panel

GND=0V, Ta=25°C

Item		Symbol	Min	Typ	Max	Unit	Remark
POWER Supply Voltage		VDD	3.00	3.30	3.30	V	
Input Signal Voltage	Low Level	V _{IL}	GND	-	0.3xVDD	V	
	High Level	V _{IH}	0.7xVDD	-	VDD	V	
Output Signal Voltage	Low Level	V _{IL}	GND	-	0.2xVDD	V	
	High Level	V _{IH}	0.8xVDD	-	VDD	V	

The information contained herein is the exclusive property of SHANGHAI TIANMA MICRO-ELECTRONICS Corporation, and shall not be distributed, reproduced, or disclosed in whole or in part without prior written permission of SHANGHAI TIANMA MICRO-ELECTRONICS Corporation.



4.2 Driving Backlight

Ta=25°C

Item	Symbol	Min	Typ	Max	Unit	Remark
Forward Current	I_F	--	20	--	mA	
Forward Current Voltage	V_F	--	3.2	--	V	
Backlight Power Consumption	W_{BL}	--	64	--	mW	

Note1: The LED driving condition is defined for each LED module

Note2: Under LCM operating, the stable forward current should be inputted. And forward voltage is for reference only.

Note3: Optical performance should be evaluated at Ta=25°C only If LED is driven by high current, high ambient temperature & humidity condition. The life time of LED will be reduced. Operating life means brightness goes down to 50% initial brightness. Typical operating life time is estimated data.

Note4: The LED driving condition is defined for each LED module.



The information contained herein is the exclusive property of SHANGHAI TIANMA MICRO-ELECTRONICS Corporation, and shall not be distributed, reproduced, or disclosed in whole or in part without prior written permission of SHANGHAI TIANMA MICRO-ELECTRONICS Corporation.



4.3 Block Diagram

LCD module diagram

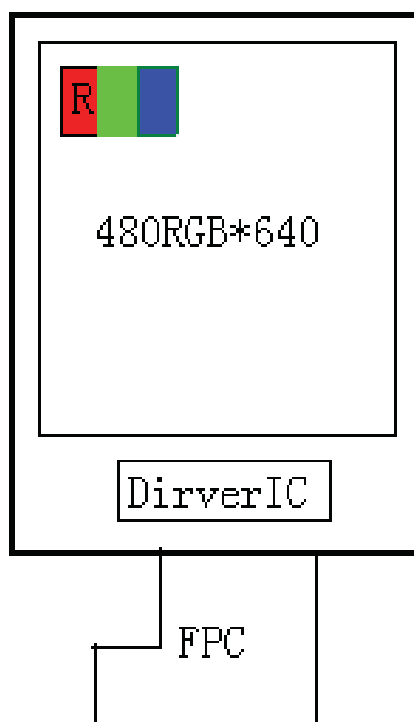

The information contained herein is the exclusive property of SHANGHAI TIANMA MICRO-ELECTRONICS Corporation, and shall not be distributed, reproduced, or disclosed in whole or in part without prior written permission of SHANGHAI TIANMA MICRO-ELECTRONICS Corporation.



5 INTERFACE TIMING

5.1 Serial Interface Characteristics(3-Pin serial)

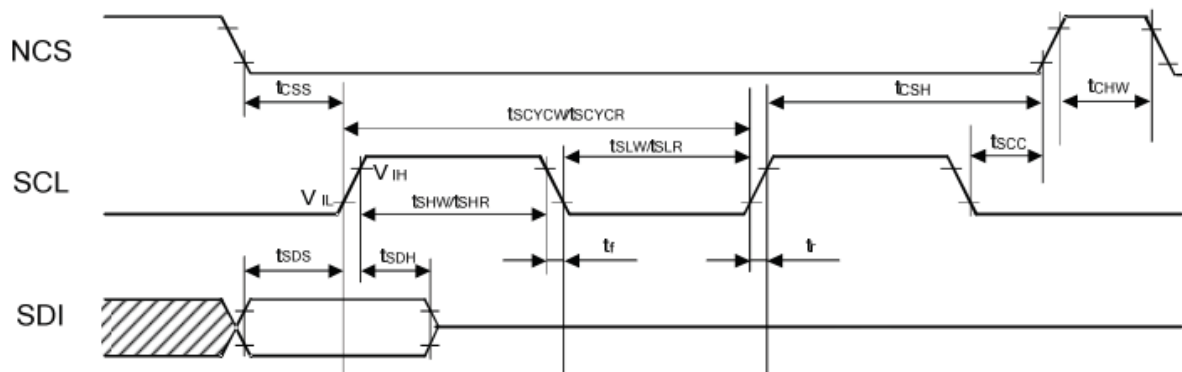

Parameter	Symbol	Conditions	Min.	Typ.	Max.	Unit
Serial clock cycle (Write)	t_{SCYCW}		80	-	-	
SCL "H" pulse width (Write)	t_{SHW}	SCL	30	-	-	ns
SCL "L" pulse width (Write)	t_{SLW}		30	-	-	
Data setup time (Write)	t_{SDS}	SDI	10	-	-	ns
Data hold time (Write)	t_{SDH}		10	-	-	
Serial clock cycle (Read)	t_{SCYCR}		150	-	-	
SCL "H" pulse width (Read)	t_{SHR}	SCL	60	-	-	ns
SCL "L" pulse width (Read)	t_{SLR}		60	-	-	
SCL to Chip select	t_{SCC}	NCS	30	-	-	ns
NCS "H" pulse width	t_{CHW}	NCS	60	-	-	ns
NCS-SCL time (write)	t_{CSS}	NCS	30	-	-	ns
NCS-SCL time (write)	t_{CSH}		30	-	-	
NCS-SCL time (Read)	t_{CSS}	NCS	60	-	-	ns
NCS-SCL time (Read)	t_{CSH}		65	-	-	

The information contained herein is the exclusive property of SHANGHAI TIANMA MICRO-ELECTRONICS Corporation, and shall not be distributed, reproduced, or disclosed in whole or in part without prior written permission of SHANGHAI TIANMA MICRO-ELECTRONICS Corporation.



5.2 Serial Data Transfer Interface

The 3-Pin serial data packet contains a control bit DNC and a transmission byte. If DNC is low, the transmission byte is command byte. If DNC is high, the transmission byte is stored to command register. The MSB is transmitted first. The serial interface is initialized when NCS is high. In this state, SCL clock pulse or SDI/SDO data have no effect. A falling edge on NCS enables the serial interface and indicates the start of data transmission.

3 wire Serial Data Stream Format

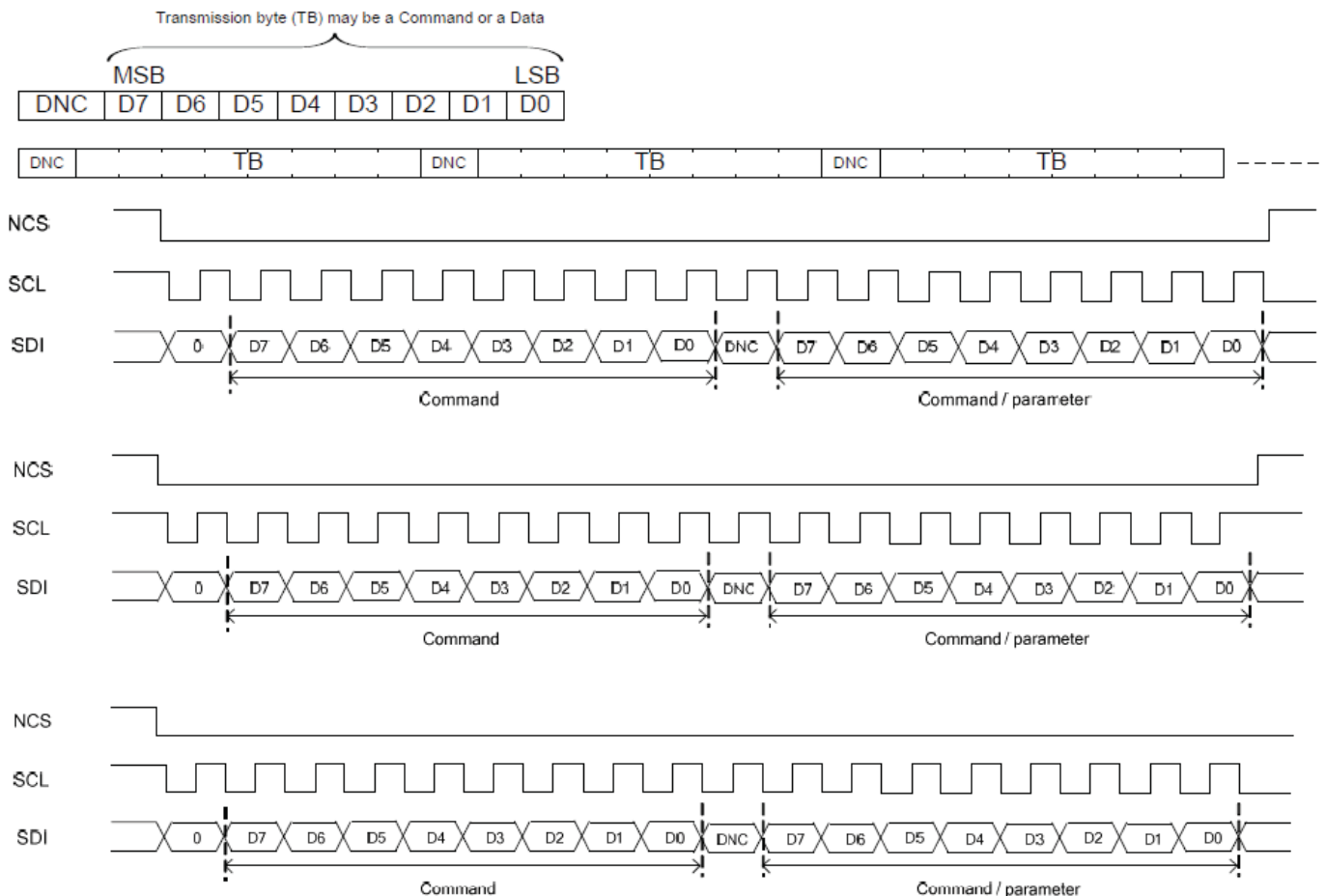

Serial Interface protocol 3 wire serial interface (write mode)

The information contained herein is the exclusive property of SHANGHAI TIANMA MICRO-ELECTRONICS Corporation, and shall not be distributed, reproduced, or disclosed in whole or in part without prior written permission of SHANGHAI TIANMA MICRO-ELECTRONICS Corporation.



5.3 RGB Interface Characteristics

5.3.1 Vertical timing for RGB I/F

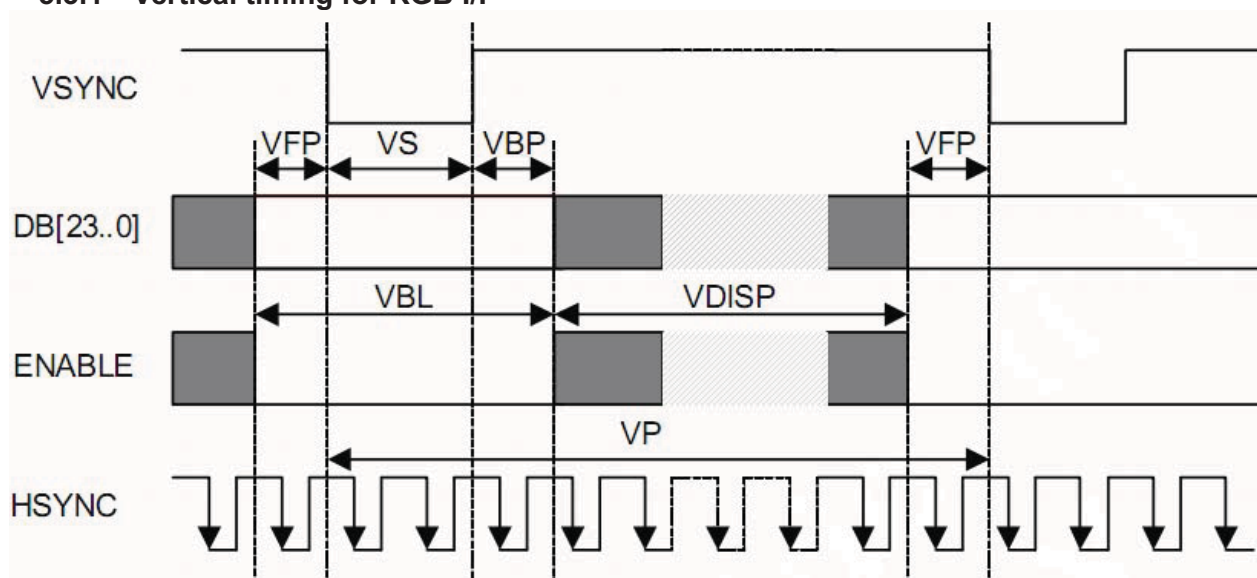

Item	Symbol	Condition	Min.	Typ.	Max.	Unit
Vertical cycle	VP	-	646	-	650	Line
Vertical low pulse width	VS	-	2	-	4	Line
Vertical front porch	VFP	-	2	-	4	Line
Vertical back porch	VBP	-	2	-	4	Line
Vertical data start point	-	VS+VBP	4	-	8	Line
Vertical blanking period	VBL	VS+VBP+VFP	6	-	10	Line
Vertical active area	-	VDISP	-	640	-	Line
Vertical Refresh rate	VRR	-	50	-	70	Hz

5.3.2 Horizontal timing for RGB I/F

The information contained herein is the exclusive property of SHANGHAI TIANMA MICRO-ELECTRONICS Corporation, and shall not be distributed, reproduced, or disclosed in whole or in part without prior written permission of SHANGHAI TIANMA MICRO-ELECTRONICS Corporation.



TIANMA MICRO-ELECTRONICS

TM035WDH01-00 V2.0

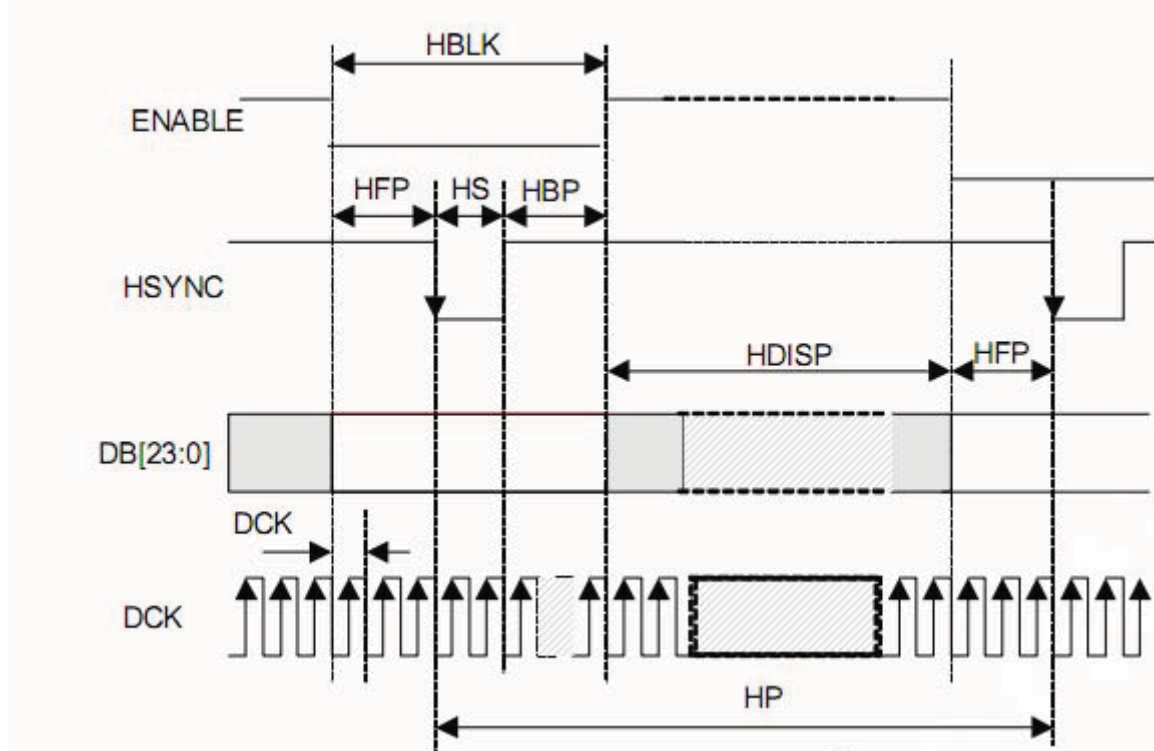

Item	Symbol	Condition	Min.	Typ.	Max.	Unit
HS cycle	HP	Note	504	-	568	DCK
HS low pulse width	HS	-	5	-	78	DCK
Horizontal back porch	HBP	-	5	-	78	DCK
Horizontal front porch	HFP	-	5	-	78	DCK
Horizontal data start point	-	HS+HBP	19	-	83	DCK
			700	-	-	ns
Horizontal blanking period	HBLK	HS+HBP+HFP	24	-	88	DCK
Horizontal active area	HDISP	-	-	480	-	DCK
Pixel clock frequency When RGB I/F is running	DCK	VRR = Min. 50Hz - Max. 70Hz	16.3	22.2	25.8	MHz
			38.7	-	61.3	ns

The information contained herein is the exclusive property of SHANGHAI TIANMA MICRO-ELECTRONICS Corporation, and shall not be distributed, reproduced, or disclosed in whole or in part without prior written permission of SHANGHAI TIANMA MICRO-ELECTRONICS Corporation.



5.3.3 General Timings for RGB I/F

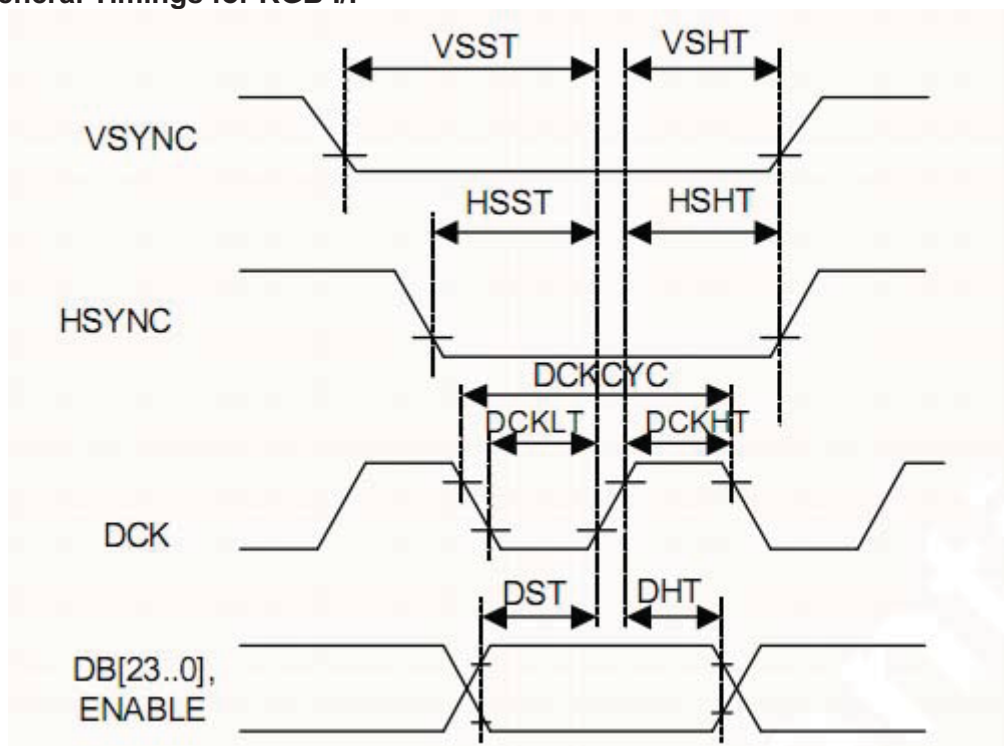

Item	Symbol	Condition	Min.	Typ.	Max.	Unit
Vertical sync. Setup time	VSST	-	5	-	-	ns
Vertical sync. Hold time	VSHT	-	5	-	-	ns
Horizontal sync. Setup time	HSST	-	5	-	-	ns
Horizontal sync. Hold time	HSHT	-	5	-	-	ns
Pixel clock low time	DCKLT	-	5	-	-	ns
Pixel clock high time	DCKHT	-	5	-	-	ns
Data setup time DB[23:0]	DST	-	5	-	-	ns
Data Hold time DB[23:0]	DHT	-	5	-	-	ns

The information contained herein is the exclusive property of SHANGHAI TIANMA MICRO-ELECTRONICS Corporation, and shall not be distributed, reproduced, or disclosed in whole or in part without prior written permission of SHANGHAI TIANMA MICRO-ELECTRONICS Corporation.



5.4 Reset Input Timing

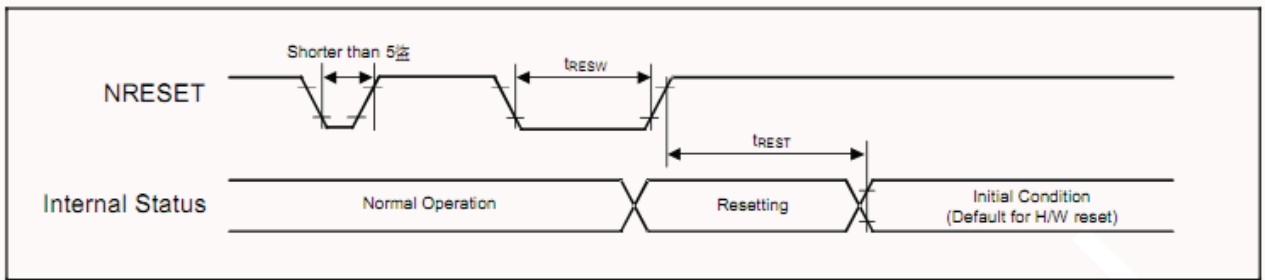

Symbol	Parameter	Related Pins	Min.	Typ.	Max.	Note	Unit
tRESW	Reset low pulse width ⁽¹⁾	NRESET	10	-	-	-	µs
tREST	Reset complete time	-	-	-	5	When reset is applied during Sleep In mode	ms
		-	-	-	120	When reset is applied during Sleep Out mode	ms

Note : (1). Spike due to an electrostatic discharge on NRESET line does not cause irregular system reset

according to the table below:

NRESET Pulse	Action
Shorter than 5µs	Reset Rejected
Longer than 10µs	Reset
Between 5µs and 10µs	Reset Start

(2) Spike Rejection also applies during a valid reset pulse as shown below:

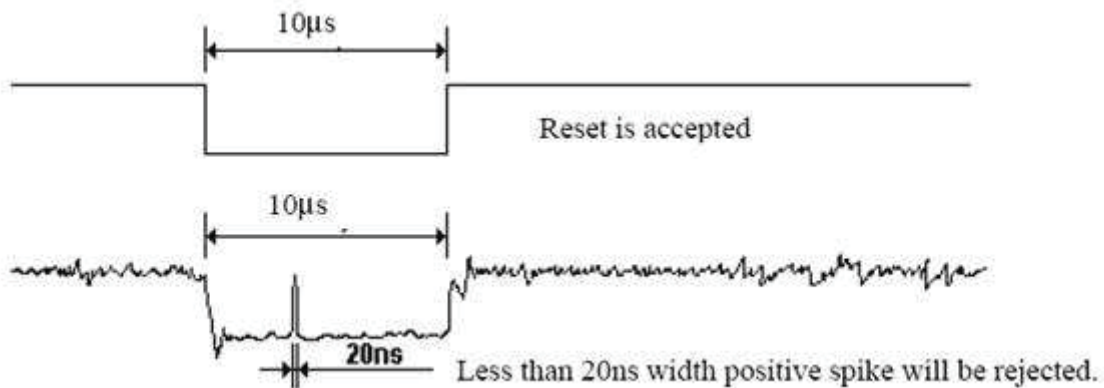

(3) It is necessary to wait 5msec after releasing NRESET before sending commands.

Also Sleep Out

command cannot be sent for 120msec.



5.5 Power ON/OFF Timing

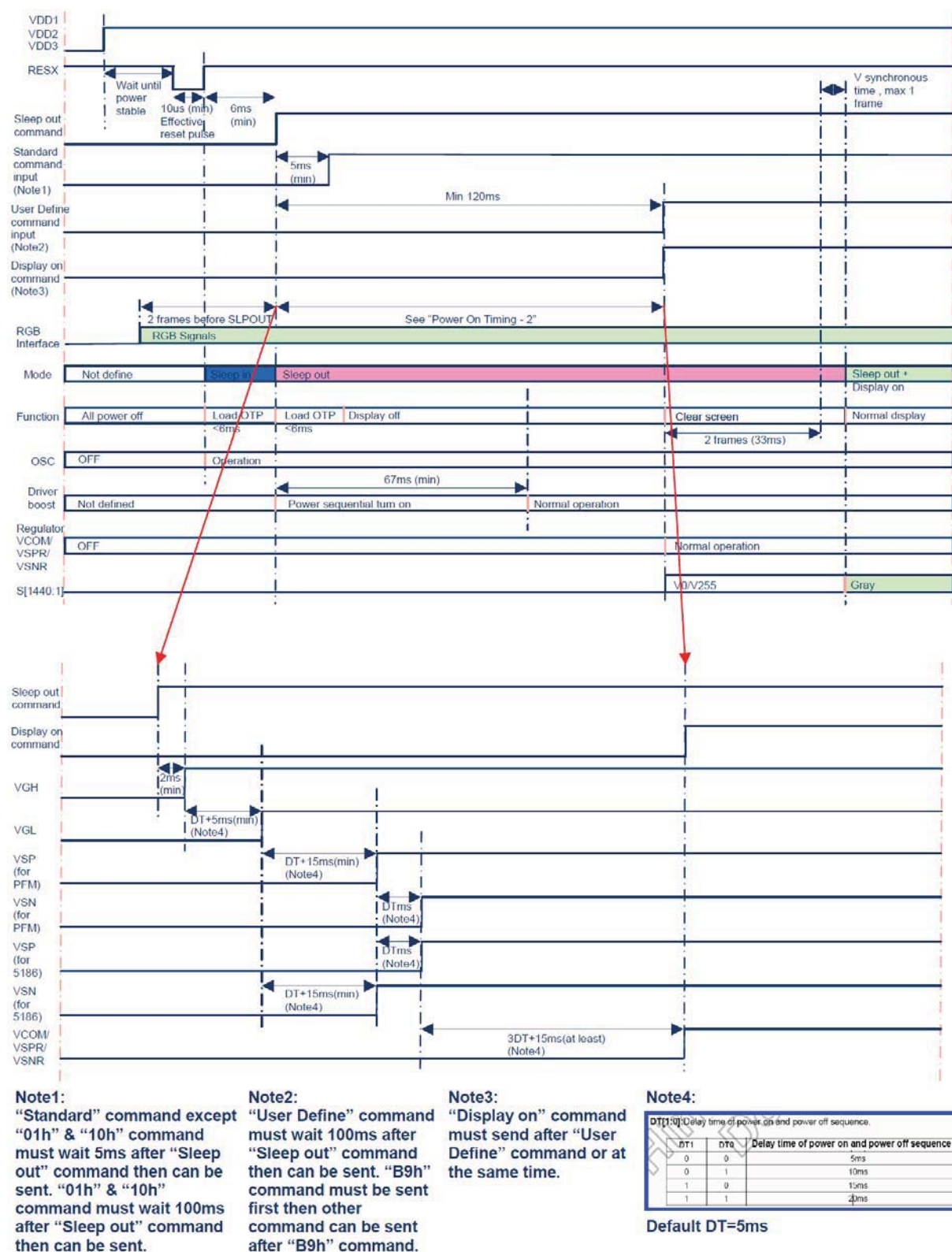

Fig 5.5.1 Power ON Timing

The information contained herein is the exclusive property of SHANGHAI TIANMA MICRO-ELECTRONICS Corporation, and shall not be distributed, reproduced, or disclosed in whole or in part without prior written permission of SHANGHAI TIANMA MICRO-ELECTRONICS Corporation.

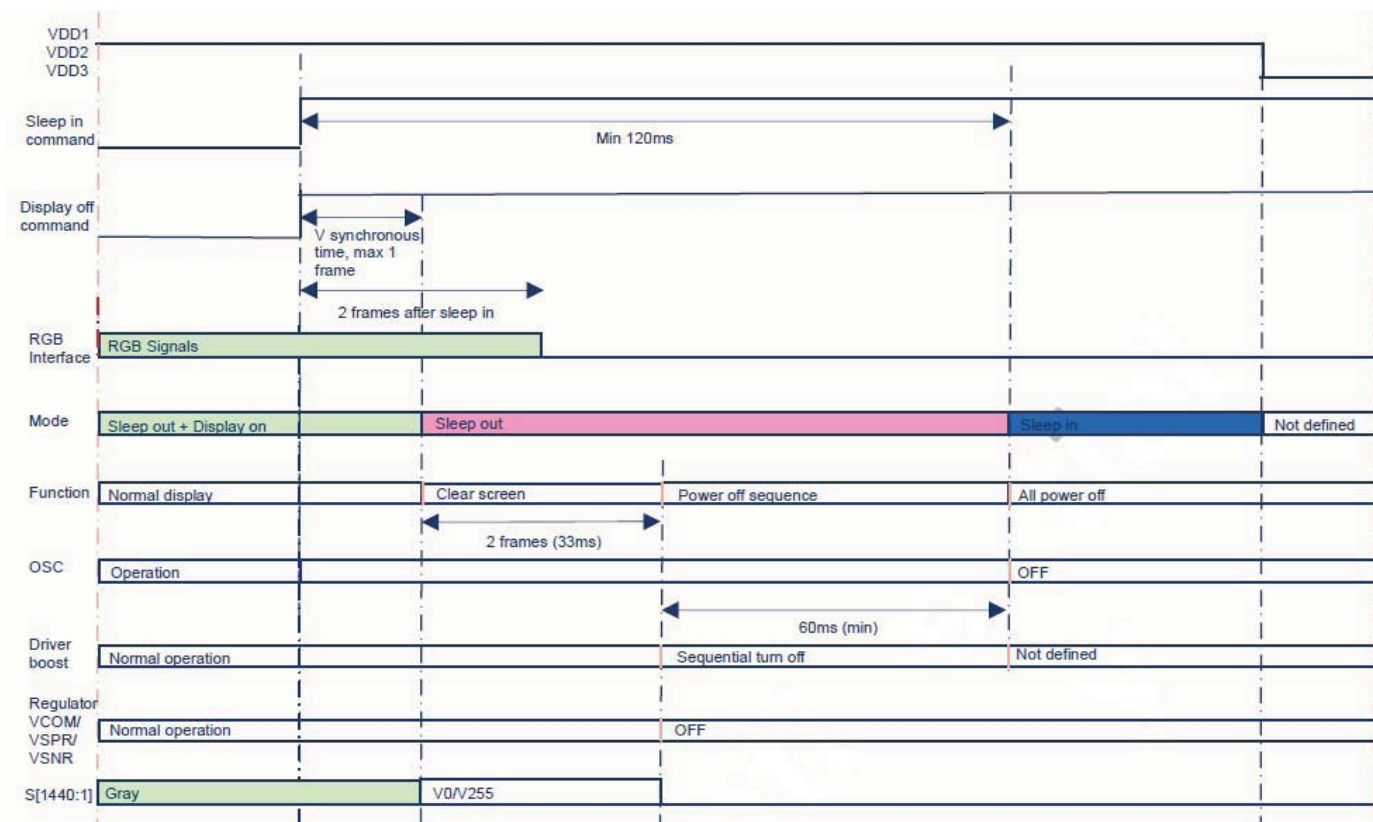

Fig 5.5.2 Power Off Timing

The information contained herein is the exclusive property of SHANGHAI TIANMA MICRO-ELECTRONICS Corporation, and shall not be distributed, reproduced, or disclosed in whole or in part without prior written permission of SHANGHAI TIANMA MICRO-ELECTRONICS Corporation.



6 Optical Characteristics

Ta=25°C

Item	Symbol	Condition	Min	Typ	Max	Unit	Remark	
View Angles	θT	$CR \geq 10$	60	70	-	Degree	Note 2	
	θB		60	70	-			
	θL		50	60	-			
	θR		60	70	-			
Contrast Ratio	CR	$\theta=0^\circ$	400	500	-	-	Note1 Note3	
Response Time	T_{ON}	25°C	-	25	35	ms	Note1	
	T_{OFF}						Note4	
Chromaticity	White	Backlight is on	x	0.251	0.301	0.351	-	Note5 Note1
			y	0.271	0.321	0.371		
	Red		x	0.530	0.580	0.630		
			y	0.27	0.320	0.37		
	Green		x	0.280	0.330	0.380		
			y	0.45	0.500	0.55		
	Blue		x	0.11	0.160	0.210		
			y	0.10	0.150	0.20		
Uniformity	U	-	70	75	-	%	Note1 Note6	
NTSC	-	-	-	50	-	%	Note 5	
Luminance	L	-	220	300	-	cd/m ²	Note1 Note7	

Test Conditions:

1. $V_F=3.2V$, $I_F=20mA$ (One LED current), the ambient temperature is 25°C.
2. The test systems refer to Note 1 and Note 2.

The information contained herein is the exclusive property of SHANGHAI TIANMA MICRO-ELECTRONICS Corporation, and shall not be distributed, reproduced, or disclosed in whole or in part without prior written permission of SHANGHAI TIANMA MICRO-ELECTRONICS Corporation.



Note 1: Definition of optical measurement system.

The optical characteristics should be measured in dark room. After 5 minutes operation, the optical properties are measured at the center point of the LCD screen. All input terminals LCD panel must be ground when measuring the center area of the panel.

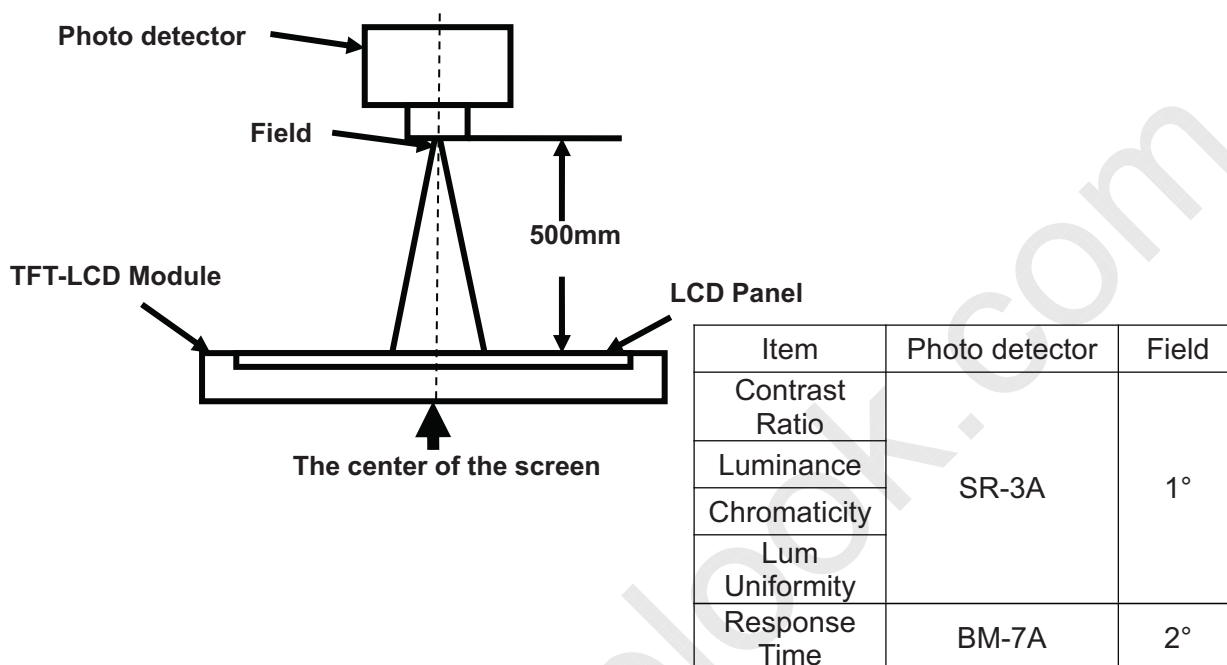

Note 2: Definition of viewing angle range and measurement system.

viewing angle is measured at the center point of the LCD by CONOSCOPE(ergo-80).

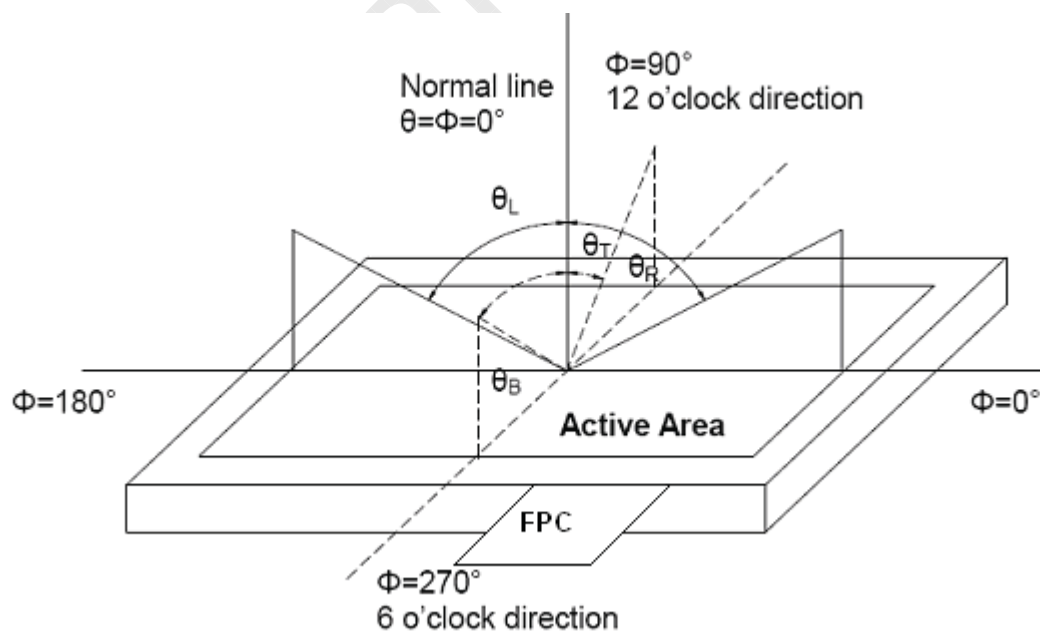

Fig. 1 Definition of viewing angle

The information contained herein is the exclusive property of SHANGHAI TIANMA MICRO-ELECTRONICS Corporation, and shall not be distributed, reproduced, or disclosed in whole or in part without prior written permission of SHANGHAI TIANMA MICRO-ELECTRONICS Corporation.



Note 3: Definition of contrast ratio

$$\text{Contrast ratio (CR)} = \frac{\text{Luminance measured when LCD is on the "White" state}}{\text{Luminance measured when LCD is on the "Black" state}}$$

"White state ":The state is that the LCD should be driven by V_{white} .

"Black state": The state is that the LCD should be driven by V_{black} .

V_{white} : To be determined V_{black} : To be determined.

Note 4: Definition of Response time

The response time is defined as the LCD optical switching time interval between "White" state and "Black" state. Rise time (T_{ON}) is the time between photo detector output intensity changed from 90% to 10%. And fall time (T_{OFF}) is the time between photo detector output intensity changed from 10% to 90%.

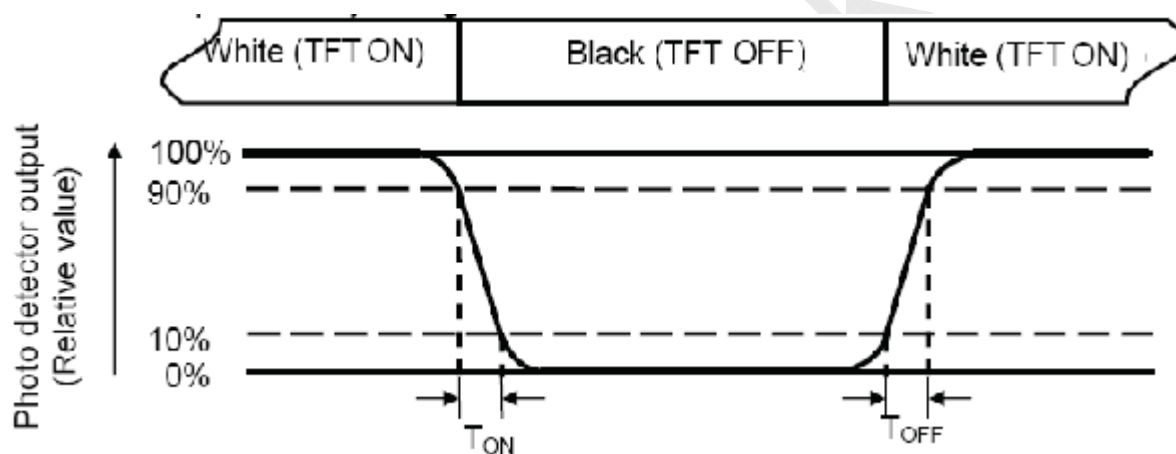

Note 5: Definition of color chromaticity (CIE1931)

Color coordinates measured at center point of LCD.



Note 6: Definition of Luminance Uniformity

Active area is divided into 9 measuring areas (Refer Fig. 2). Every measuring point is placed at the center of each measuring area.

Luminance Uniformity (U) = L_{min} / L_{max}

L-----Active area length W----- Active area width

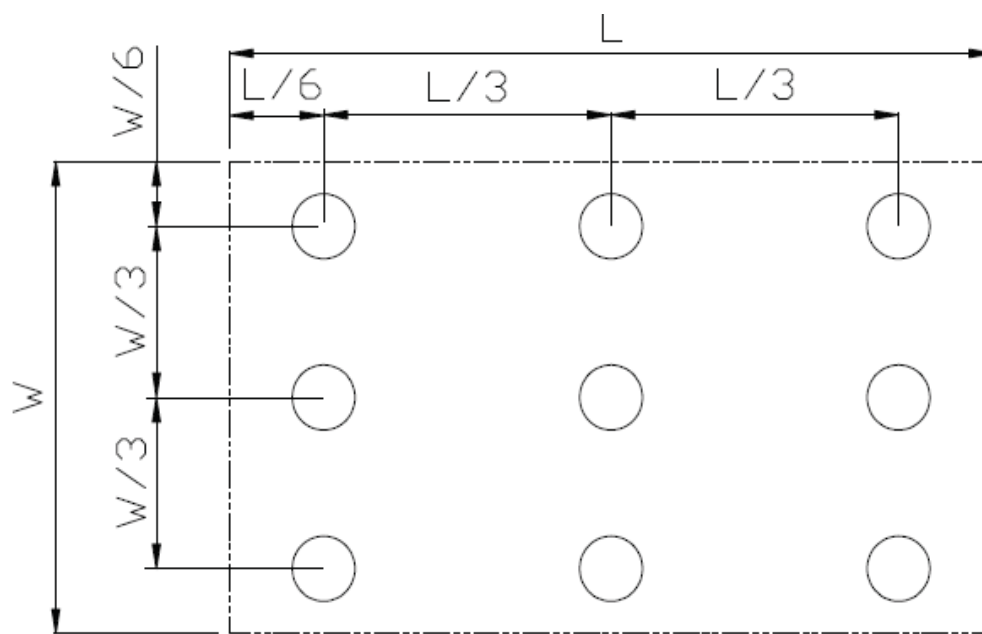

Fig. 2 Definition of uniformity

L_{max} : The measured maximum luminance of all measurement position.

L_{min} : The measured minimum luminance of all measurement position.

Note 7: Definition of Luminance:

Measure the luminance of white state at center point.



7 Environmental / Reliability Test

No	Test Item	Condition	Remark
1	High Temperature Operation	Ts=+70°C, 120hrs	Note1 IEC60068-2-1:2007,GB2423.2-2008
2	Low Temperature Operation	Ta=-20°C, 120hrs	IEC60068-2-1:2007 GB2423.1-2008
3	High Temperature Storage	Ta=+80°C, 120hrs	IEC60068-2-1:2007 GB2423.2-2008
4	Low Temperature Storage	Ta=-30°C, 120hrs	IEC60068-2-1:2007 GB2423.1-2008
5	High Temperature & High Humidity Storage	Ta=+60°C, 90% RH 120 hours	Note2 IEC60068-2-78 :2001 GB/T2423.3—2006
6	Thermal Shock (Non-operation)	-30°C 30 min~+70°C 30 min, Change time:5min, 20 Cycles	Start with cold temperature, End with high temperature, IEC60068-2-14:1984,GB2423.22-2002
7	Electro Static Discharge (Operation)	C=150pF, R=330Ω,5points/panel Air:± 10KV, 5times, Contact:± 4KV, 5 times, (Environment: 15°C ~ 35°C, 30% ~ 60%, 86Kpa ~ 106Kpa)	IEC61000-4-2:2001 GB/T17626.2-2006
8	Vibration (Non-operation)	Frequency range:10~55Hz, Stroke:1.5mm Sweep:10Hz~55Hz~10Hz hours for each direction of X.Y.Z. (6 hours for total)(Package condition)	2 IEC60068-2-6:1982 GB/T2423.10—1995
9	Shock (Non-operation)	60G 6ms, ± X,± Y,± Z 3times, for each direction	IEC60068-2-27:1987 GB/T2423.5—1995
10	Package Drop Test	Height:80 cm, 1 corner, 3 edges, 6 surfaces	IEC60068-2-32:1990 GB/T2423.8—1995

Note1: Ts is the temperature of panel's surface.

Note2: Ta is the ambient temperature of sample.

The information contained herein is the exclusive property of SHANGHAI TIANMA MICRO-ELECTRONICS Corporation, and shall not be distributed, reproduced, or disclosed in whole or in part without prior written permission of SHANGHAI TIANMA MICRO-ELECTRONICS Corporation.



TIANMA MICRO-ELECTRONICS

TM035WDH01-00 V2.0

8 Mechanical Drawing

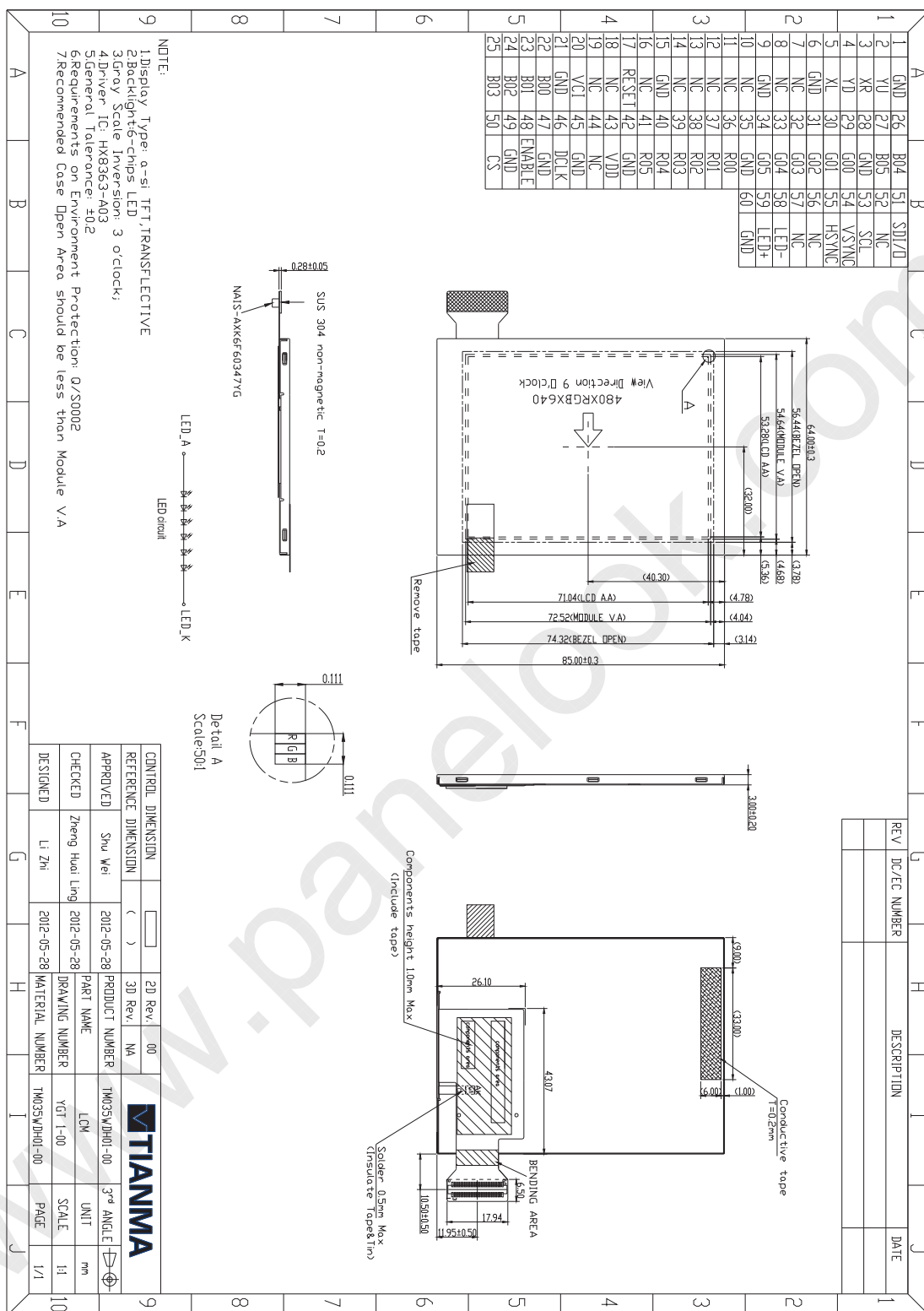

1

The information contained herein is the exclusive property of SHANGHAI TIANMA MICRO-ELECTRONICS Corporation, and shall not be distributed, reproduced, or disclosed in whole or in part without prior written permission of SHANGHAI TIANMA MICRO-ELECTRONICS Corporation.



TIANMA MICRO-ELECTRONICS

TM035WDH01-00 V2.0

9 Packing Drawing

No	Item	Model (Material)	Dimensions(mm)	Unit Weight(Kg)	Quantity	Remark
1	LCM module	TM035WDH01-00	64.0x85.0x3.0	0.034	252	
2	Tray	PET (Transmit)	485×330×13.8	0.170	21	Anti-static
3	EPE	EPE	485×330×5	0.0183	3	
4	Dust-Proof Bag	PE	700×545	0.021	1	
5	BOX	CORRUGATED PAPER	520×345×74	0.3879	3	
6	Desiccant	Desiccant	45×35	0.002	6	
7	Carton	CORRUGATED PAPER	544×365×250	1.01	1	
8	Total weight	14.4±5% Kg				

The information contained herein is the exclusive property of SHANGHAI TIANMA MICRO-ELECTRONICS Corporation, and shall not be distributed, reproduced, or disclosed in whole or in part without prior written permission of SHANGHAI TIANMA MICRO-ELECTRONICS Corporation.



10 Precautions For Use of LCD Modules

10.1 Handling Precautions

- 10.1.1 The display panel is made of glass. Do not subject it to a mechanical shock by dropping it from a high place, etc.
- 10.1.2 If the display panel is damaged and the liquid crystal substance inside it leaks out, be sure not to get any in your mouth, if the substance comes into contact with your skin or clothes, promptly wash it off using soap and water.
- 10.1.3 Do not apply excessive force to the display surface or the adjoining areas since this may cause the color tone to vary.
- 10.1.4 The polarizer covering the display surface of the LCD module is soft and easily scratched. Handle this polarizer carefully.
- 10.1.5 If the display surface is contaminated, breathe on the surface and gently wipe it with a soft dry cloth. If still not completely clear, moisten cloth with one of the following solvents:
 - Isopropyl alcohol
 - Ethyl alcoholSolvents other than those mentioned above may damage the polarizer. Especially, do not use the following:
 - Water
 - Ketone
 - Aromatic solvents
- 10.1.6 Do not attempt to disassemble the LCD Module.
- 10.1.7 If the logic circuit power is off, do not apply the input signals.
- 10.1.8 To prevent destruction of the elements by static electricity, be careful to maintain an optimum work environment.
 - 10.1.8.1 Be sure to ground the body when handling the LCD Modules.
 - 10.1.8.2 Tools required for assembly, such as soldering irons, must be properly ground.
 - 10.1.8.3 To reduce the amount of static electricity generated, do not conduct assembly and other work under dry conditions.
 - 10.1.8.4 The LCD Module is coated with a film to protect the display surface. Be care when peeling off this protective film since static electricity may be generated.

10.2 Storage precautions

- 10.2.1 When storing the LCD modules, avoid exposure to direct sunlight or to the light of fluorescent lamps.
- 10.2.2 The LCD modules should be stored under the storage temperature range. If the LCD modules will be stored for a long time, the recommend condition is:
Temperature : 0°C ~ 40°C Relatively humidity: ≤80%
- 10.2.3 The LCD modules should be stored in the room without acid, alkali and harmful gas.

10.3 Transportation Precautions

The LCD modules should be no falling and violent shocking during transportation, and also should avoid excessive press, water, damp and sunshine.

The information contained herein is the exclusive property of SHANGHAI TIANMA MICRO-ELECTRONICS Corporation, and shall not be distributed, reproduced, or disclosed in whole or in part without prior written permission of SHANGHAI TIANMA MICRO-ELECTRONICS Corporation.