

Product Specification

SPECIFICATION FOR APPROVAL

- () Preliminary Specification
- () Final Specification

Title	12.1" XGA TFT LCD
-------	-------------------

BUYER	DELL
MODEL	

SUPPLIER	LG.Philips LCD CO., Ltd.
*MODEL	LP121X1
SUFFIX	A2M1

*When you obtain standard approval,
please use the above model name without suffix

SIGNATURE	DATE
_____/_____ 	_____
_____/_____ 	_____
_____/_____ 	_____

Please return 1 copy for your confirmation with your signature and comments.

APPROVED BY	DATE
S. W. Lee /G.Manager _____	_____
REVIEWED BY	
J. H. Park / Manager _____	_____
PREPARED BY	
S. R. Kim / Engineer _____	_____

**Product Engineering Dept.
LG. Philips LCD Co., Ltd**

Product Specification

NO.	ITEM	Page
-	COVER	1
-	CONTENTS	2
-	RECORD OF REVISIONS	3
1	GENERAL DESCRIPTION	4
2	ABSOLUTE MAXIMUM RATINGS	5
3	ELECTRICAL SPECIFICATIONS	
3-1	ELECTRICAL CHARACTREISTICS	6
3-2	INTERFACE CONNECTIONS	8
3-3	SIGNAL TIMING SPECIFICATIONS	10
3-4	SIGNAL TIMING WAVEFORMS	11
3-5	COLOR INPUT DATA REFERNECE	12
3-6	POWER SEQUENCE	13
4	OPTICAL SPECIFICATIONS	14
5	MECHANICAL CHARACTERISTICS	18
6	RELIABILITY	22
7	INTERNATIONAL STANDARDS	
7-1	SAFETY	23
7-2	EMC	23
8	PACKING	
8-1	DESIGNATION OF LOT MARK	24
8-2	PAKING FORM	24
9	PRECAUTIONS	25

Product Specification

RECORDS OF REVISIONS

Revision No	Revision Date	Page	DESCRIPTION
0.0	JUN 27, 2000	-	First Draft.
0.1	SEP 30, 2000		Fix some specification against TBD.
1.0	JAN 03, 2001		Final CAS.

Product Specification

1. General Description

The LP121X1-A2M1 is a Color Active Matrix Liquid Crystal Display with an integral Cold Cathode Fluorescent Lamp(CCFL) backlight system. The matrix employs a-Si Thin Film Transistor as the active element. It is a transmissive type display operating in the normally white mode. This TFT-LCD has 12.1 inches diagonally measured active display area with XGA resolution(768 vertical by 1024 horizontal pixel array) Each pixel is divided into Red, Green and Blue sub-pixels or dots which are arranged in vertical stripes. Gray scale or the brightness of the sub-pixel color is determined with a 6-bit gray scale signal for each dot, thus, presenting a palette of more than 262,144 colors.

The LP121X1-A2M1 has been designed to apply the interface method that enables low power, high speed, low EMI. Flat Link must be used as a LVDS(Low Voltage Differential Signaling) chip.

The LP121X1-A2M1 is intended to support applications where thin thickness, low power are critical factors and graphic display are important. In combination with the vertical arrangement of the sub-pixels, the LP121X1-A2M1 characteristics provide an excellent flat display for office automation products such as Notebook PC.

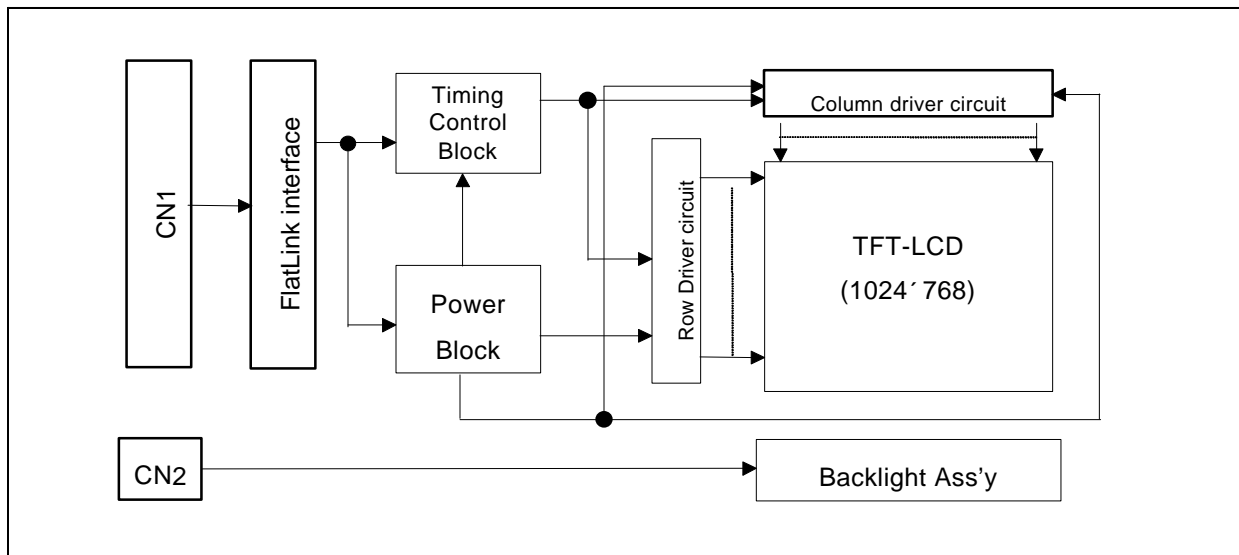

General Features

Active screen size	12.1 inches(30.73cm) diagonal
Outline Dimension	261(H) x 199(V) x 5.4(D) mm(Typ.)
Pixel Pitch	0.240 mm x 0.240mm
Pixel format	1024 horiz. By 768 vert. Pixels RGB stripes arrangement
Color depth	6-bit, 262,144 colors
Luminance, white	130 cd/m ² (Typ.)
Power Consumption	Total 4.5 Watt(Typ.)
Weight	390g(Typ.)
Display operating mode	Transmissive mode, normally white
Surface treatments	Hard coating(3H) Anti-glare treatment of the front polarizer, HAZE(13%)

Product Specification

2. Absolute Maximum Ratings

The following are maximum values which, if exceeded, may cause operation or damage to the unit.

Table 1. ABSOLUTE MAXIMUM RATINGS

Parameter	symbol	Values		Units	Notes
		Min.	Max.		
Power Input Voltage	V_{CC}	-0.3	4.0	Vdc	At $25 \pm 5^\circ\text{C}$
Operating Temperature	T_{OP}	0	50	$^\circ\text{C}$	1
Storage Temperature	T_{ST}	-20	60	$^\circ\text{C}$	1
Operating Ambient Humidity	H_{OP}	10	90	%RH	1
Storage Humidity	H_{ST}	10	90	%RH	1

Note : 1. Temperature and relative humidity range are shown in the figure below.
 Wet bulb temperature should be 39°C Max, and no condensation of water.

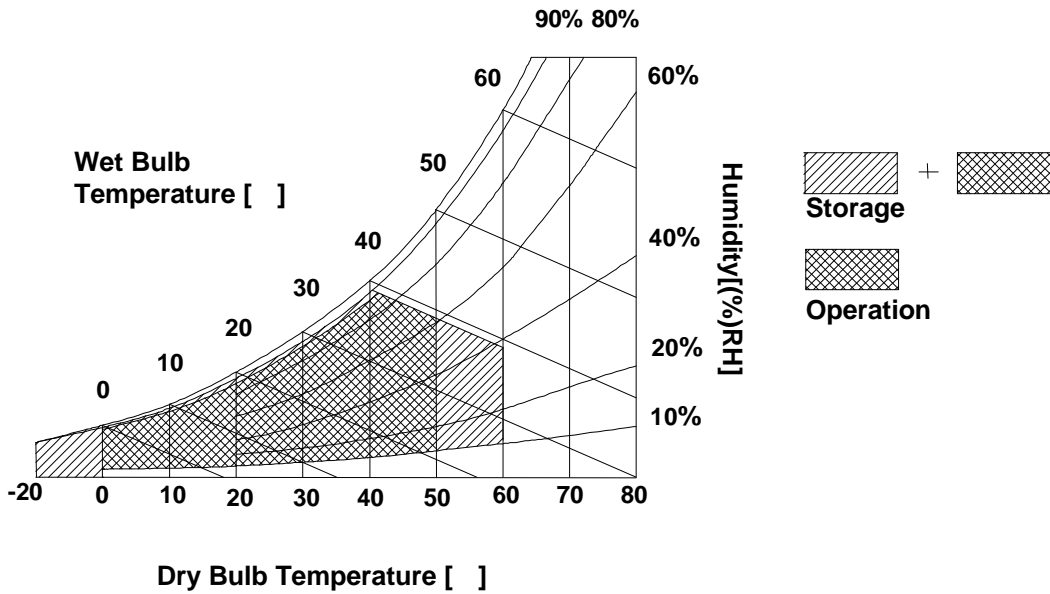

Product Specification

3. Electrical Specifications

3-1. Electrical Characteristics

The LP121X1-A2M1 requires two power inputs. One is employed to power the LCD electronics and to drive the TFT array and liquid crystal. The second input which powers the CCFL, is typically generated by an inverter. The inverter is an external unit to the LCD.

Table 2. ELECTRICAL CHARACTERISTICS

Parameter	Symbol	Values			Units	Notes
		Min.	Typ.	Max.		
MODULE :						
Power Supply Input Voltage	V_{CC}	3.0	3.3	3.6	Vdc	
Power Supply Input Current	I_{CC}	-	0.270	0.440	A	1
Differential Impedance	Z_m	90	100	110	ohm	2
Power Consumption	P_C	0.85	0.89	1.45	Watts	1
Rush Current	I_{RUSH}		1.0	1.5	A	3
LAMP :						
Operating Voltage	V_{BL}	580	620	682	V_{RMS}	4
Operating Current	I_{BL}	3.0	5.5	6.0	mA	
Established Starting Voltage	V_S					5
at 25 °C		-	-	770	V_{RMS}	
at 0 °C		-	-	1150	V_{RMS}	
Operating Frequency	f_{BL}	45	55	80	kHz	4
Discharge Stabilization Time	T_S			3	Minutes	5
Power Consumption	P_{BL}		3.41	3.75	Watts	6
Life Time		10,000	-	-	Hrs	7

Note : **The design of the inverter must have specification for the lamp in LCD Assembly.**

The performance of the Lamp in LCM, for example life time or brightness, is extremely influenced by the characteristics of the DC-AC inverter. So all the parameters of an inverter should be carefully designed so as not to produce too much leakage current from high-voltage output of the inverter.

When you design or order the inverter, please make sure unwanted lighting caused by the mismatch of the lamp and the inverter(no lighting, flicker, etc) never occurs. When you confirm it, the LCD Assembly should be operated in the same condition as installed in you instrument.

1. The specified current and power consumption are under the $V_{CC}=3.3V$, $25^{\circ}C$, $f_v=60Hz$ condition whereas full black pattern is displayed and f_v is the frame frequency.
2. This impedance value is needed to proper display and measured from LVDS T_x to the mating connector.
3. The duration of rush current is about 20ms.
4. The variance of the voltage is $\pm 10\%$.
5. The voltage above V_S should be applied to the lamps for more than 1 second for start-up. Otherwise, the lamps may not be turned on.

Product Specification

6. The output of the inverter must have symmetrical(negative and positive) voltage waveform and symmetrical current waveform.(Asymmetrical ratio is less than 10%) Please do not use the inverter which has asymmetrical voltage and asymmetrical current and spike wave.
Lamp frequency may produce interface with horizontal synchronous frequency and as a result this may cause beat on the display. Therefore lamp frequency shall be as away possible from the horizontal synchronous frequency and from its harmonics in order to prevent interference.
7. It is defined the brightness of the lamp after being lighted for 5 minutes as 100%.
 T_S is the time required for the brightness of the center of the lamp to be not less than 95%.
8. The lamp power consumption shown above does not include loss of external inverter.
The used lamp current is the lamp typical current.
9. The life is determined as the time at which brightness of the lamp is 50% compared to that of initial value at the typical lamp current on condition of continuous operating at $25 \pm 2^\circ\text{C}$.
10. Do not attach a conducting tape to lamp connecting wire.
If the lamp wire attach to a conducting tape, TFT-LCD Module has a low luminance and the inverter has abnormal action. Because leakage current is occurred between lamp wire and conducting tape.

Product Specification

3-2. Interface Connections

Interface chip must be used FlatLink, part No. SN75LVDS84(Transmitter made by Texas Instrument Inc or equivalence.

This LCD employs two interface connections, a 20 pin connector is used for the module electronics and the other connector is used for the integral backlight system.

The electronics interface connector is a model DF19K-20P-1H manufactured by Hirose or equivalent.

The pin configuration for the connector is shown in the table below.

Table 3. MODULE CONNECTOR PIN CONFIGURATION(LVDS)

Pin	Symbol	Description	Notes
1	Vcc	Power(3.3V)	1. Interface chips 1.1 LCD : SN75LVDS88B(LCD Controller) including LVDS Receiver 1.2 System : SN75LVDS84 or equivalent *Pin to Pin compatible with Thine LVDS 2. Connector 2.1 LCD : DF19K-20P-1H,HIROSE or equivalent 2.2 Mating : DF19G-20S-1C or equivalent. 2.3 Connector pin arrangement
2	Vcc	Power(3.3V)	
3	GND	Ground	
4	GND	Ground	
5	A1M	Differential Signal	
6	A1P	Differential Signal	
7	GND	Ground	
8	A2M	Differential Signal	
9	A2P	Differential Signal	
10	GND	Ground	
11	A3M	Differential Signal	
12	A3P	Differential Signal	
13	GND	Ground	
14	CLKM	Differential Signal	
15	CLKP	Differential Signal	
16	GND	Ground	
17	NC	No Connection	
18	NC	No Connection	
19	GND	Ground	
20	GND	Ground	

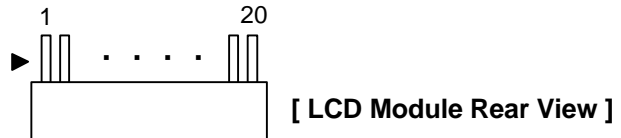

The backlight interface connector is a model BHSR-02VS-1, manufactured by JST. The mating connector part number is SM02B-BHSS-1 or equivalent.

The pin configuration for the connector is shown in the table below.

Table 4. BACKLIGHT CONNECTOR PIN CONFIGURATION

Pin	Symbol	Description	Notes
1	HV	Power supply for lamp (High voltage side)	1
2	LV	Power supply for lamp (Low voltage side)	1

Notes : 1. The high voltage side terminal is colored pink. The low voltage side terminal is white

Product Specification

Table 5. REQUIRED SIGNAL ASSIGNMENT FOR FlatLink Transmitter

Pin#	Pin Name	Require Signals	Pin#	Pin Name	Require Signals
1	D4	R4	48	D3	R3
2	Vcc	Vcc	47	D2	R2
3	D5	R5	46	GND	GND
4	D6	G0	45	D1	R1
5	GND	GND	44	D0	R0
6	D7	G1	43	NC	NC
7	D8	G2	42	LVDS GND	LVDS GND
8	Vcc	Vcc	41	Y0M	A0M
9	D9	G3	40	Y0P	A0P
10	D10	G4	39	Y1M	A1M
11	GND	GND	38	Y1P	A1P
12	D11	G5	37	LVDS Vcc	LVDS Vcc
13	D12	B0	36	LVDS GND	LVDS GND
14	NC	NC	35	Y2M	A2M
15	D13	B1	34	Y2P	A2P
16	D14	B2	33	CLKOUTM	CLKM
17	GND	GND	32	CLKOUTP	CLKP
18	D15	B3	31	LVDS GND	LVDS GND
19	D16	B4	30	PLL GND	PLL GND
20	D17	B5	29	PLL Vcc	PLL Vcc
21	Vcc	Vcc	28	PLL GND	PLL GND
22	D18	HSYNC	27	$\overline{\text{SHDN}}$	$\overline{\text{SHDN}}$
23	D19	VSYNC	26	CLKIN	Dclk
24	GND	GND	25	D20	DE(Data Enable)

Notes : Refer to LVDS Transmitter Data Sheet for detail descriptions.

Product Specification

3-3. Signal Timing Specifications

This is the signal timing required at the input of the LVDS Transmitter. All of the interface signal timing should be satisfied with the following specifications for its proper operation.

Table 6. Timing Table

	ITEM	SYMBOL	MIN	TYP.	MAX.	UNIT	NOTES
Dclk	Period	t_{CLK}	16.1	15.4	14.7	ns	
	Frequency	-	62	65	68	MHz	
Hsync	Period	t_{HP}	1196	1344	1364	t_{CLK}	
	Width	t_{WH}	8	136	240		
Vsync	Period	t_{VP}	780	806	830	t_{HP}	
	Frequency	f_V	-	60	-	Hz	
	Width	t_{WV}	1	6	24	t_{HP}	
DE (Data Enable)	Set up Time	t_{SI}	5	-	-	ns	For Dclk
	Hold Time	t_{HI}	5	-	-		
	Horizontal Back Porch	t_{HBP}	10	160	-	t_{CLK}	
	Horizontal Front Porch	t_{HFP}	10	24	-		
	Vertical Back Porch	t_{VBP}	2	29	-	t_{HP}	
	Vertical Front Porch	t_{VFP}	1	3	-		
DATA	Set up Time	t_{SD}	5	-	-	ns	For Dclk
	Hold Time	t_{HD}	5	-	-		

Product Specification

3-4. Signal Timing Waveforms

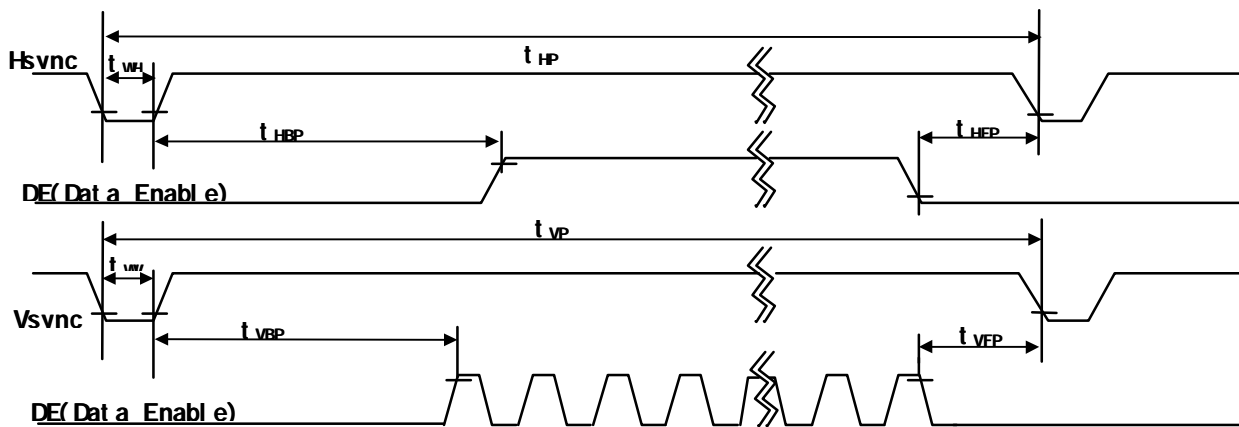
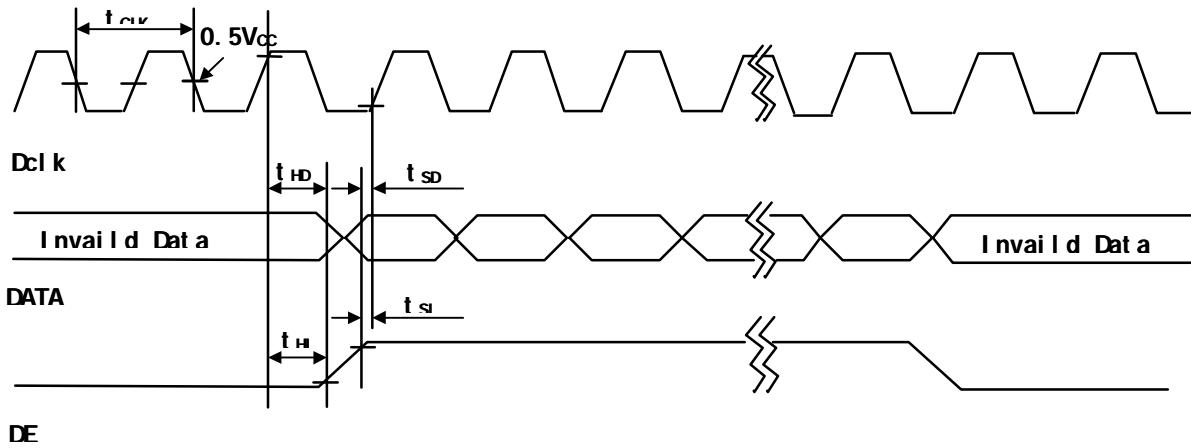
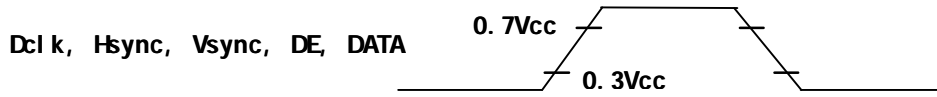

Product Specification

3-5. Color Input Data Reference

The brightness of each primary color(red,green and blue) is based on the 6-bit gray scale data input for the color ; the higher the binary input, the brighter the color. The table below provides a reference for color versus data input.

Table 7. COLOR DATA REFERENCE

Color		Input Color Data																	
		Red						Green						Blue					
		MSB			LSB			MSB			LSB			MSB			LSB		
		R5	R4	R3	R2	R1	R0	G5	G4	G3	G2	G1	G0	B5	B4	B3	B2	B1	B0
Basic Colors	Black	0	0	0	0	0	0	0	0	0	0	0	0	0	0	0	0	0	0
	Red(63)	1	1	1	1	1	1	0	0	0	0	0	0	0	0	0	0	0	0
	Green(63)	0	0	0	0	0	0	1	1	1	1	1	1	0	0	0	0	0	0
	Blue(63)	0	0	0	0	0	0	0	0	0	0	0	0	1	1	1	1	1	1
	Cyan	0	0	0	0	0	0	1	1	1	1	1	1	1	1	1	1	1	1
	Magenta	1	1	1	1	1	1	0	0	0	0	0	0	1	1	1	1	1	1
	Yellow	1	1	1	1	1	1	1	1	1	1	1	1	0	0	0	0	0	0
	White	1	1	1	1	1	1	1	1	1	1	1	1	1	1	1	1	1	1
Red	Red(00) Dark	0	0	0	0	0	0	0	0	0	0	0	0	0	0	0	0	0	0
	Red(01)	0	0	0	0	0	1	0	0	0	0	0	0	0	0	0	0	0	0
	Red(02)	0	0	0	0	1	0	0	0	0	0	0	0	0	0	0	0	0	0
	:	:	:	:	:	:	:	:	:	:	:	:	:	:	:	:	:	:	:
	Red(61)	1	1	1	1	0	1	0	0	0	0	0	0	0	0	0	0	0	0
	Red(62)	1	1	1	1	1	0	0	0	0	0	0	0	0	0	0	0	0	0
	Red(63) Bright	1	1	1	1	1	1	0	0	0	0	0	0	0	0	0	0	0	0
Green	Green(00)Dark	0	0	0	0	0	0	0	0	0	0	0	0	0	0	0	0	0	0
	Green(01)	0	0	0	0	0	0	0	0	0	0	0	1	0	0	0	0	0	0
	Green(02)	0	0	0	0	0	0	0	0	0	0	1	0	0	0	0	0	0	0
	:	:	:	:	:	:	:	:	:	:	:	:	:	:	:	:	:	:	:
	Green(61)	0	0	0	0	0	0	1	1	1	1	0	1	0	0	0	0	0	0
	Green(62)	0	0	0	0	0	0	1	1	1	1	1	0	0	0	0	0	0	0
	Green(63)Bright	0	0	0	0	0	0	1	1	1	1	1	1	0	0	0	0	0	0
Blue	Blue(00) Dark	0	0	0	0	0	0	0	0	0	0	0	0	0	0	0	0	0	0
	Blue(01)	0	0	0	0	0	0	0	0	0	0	0	0	0	0	0	0	0	1
	Blue(02)	0	0	0	0	0	0	0	0	0	0	0	0	0	0	0	0	1	0
	:	:	:	:	:	:	:	:	:	:	:	:	:	:	:	:	:	:	:
	Blue(61)	0	0	0	0	0	0	0	0	0	0	0	0	1	1	1	1	0	1
	Blue(62)	0	0	0	0	0	0	0	0	0	0	0	0	1	1	1	1	1	0
	Blue(63) Bright	0	0	0	0	0	0	0	0	0	0	0	0	1	1	1	1	1	1

Product Specification

3-6. Power Sequence

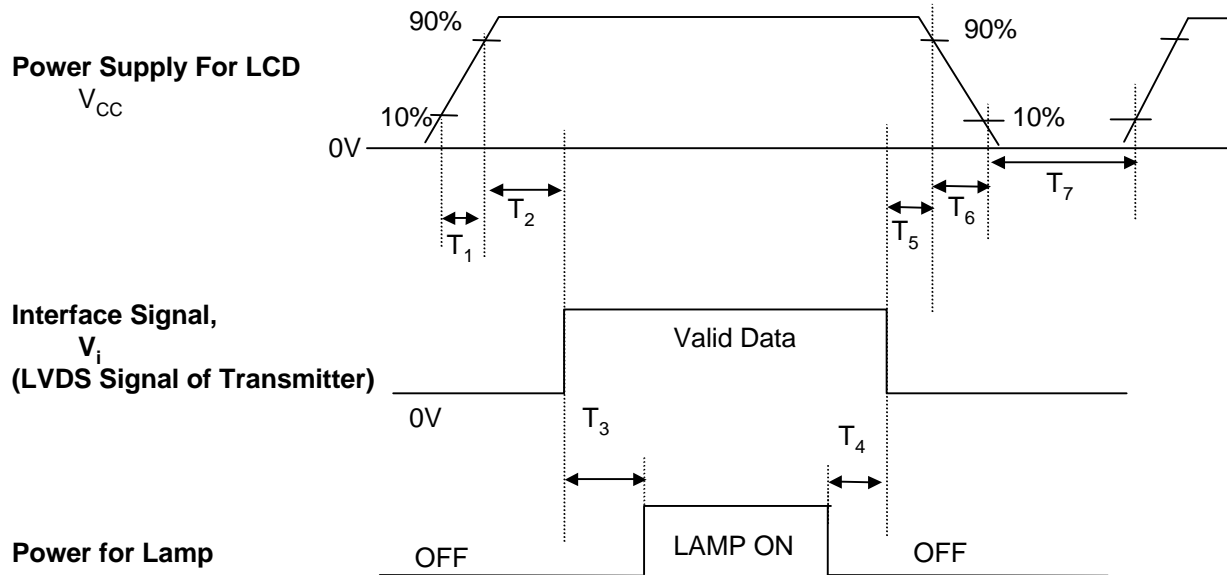

Parameter	Values			Units
	Min.	Typ.	Max.	
T_1	-	-	10	ms
T_2	0	-	50	ms
T_3	200	-	-	ms
T_4	200	-	-	ms
T_5	0	-	50	ms
T_6	-	-	10	ms
T_7	400	-	-	ms

- Notes :**
1. Please avoid floating state of interface signal at invalid period.
 2. When the interface signal is invalid, be sure to pull down the power supply for LCD V_{CC} to 0V.
 3. Lamp power must be turn on after power supply for LCD and interface signal are valid.

Product Specification

Notes : 1. Contrast Ratio(CR) is defined mathematically as :

$$\text{Contrast Ratio} = \frac{\text{Surface Luminance with all white pixels}}{\text{Surface Luminance with all black pixels}}$$

2. Surface luminance is the 5 point average across the LCD surface 50cm from the surface with all pixels displaying white. For more information see FIG 2.

When $I_{BL}=5.5\text{mA}$, $L_{WH}=130\text{cd/m}^2(\text{Typ.})$

3. The variation in surface luminance, $\delta \text{ WHITE}$ is determined by measuring L_{ON} at each test position 1 through 5, and then dividing the maximum L_{ON} of 5 points luminance by minimum L_{ON} of 5 points luminance. For more information see FIG 2.

$$\delta \text{ WHITE} = \text{Maximum}(L_{ON1}, L_{ON2}, \dots, L_{ON5}) \div \text{Minimum}(L_{ON1}, L_{ON2}, \dots, L_{ON5})$$

4. Response time is the time required for the display to transition from to black(Rise Time, Tr_R) and from black to white(Decay Time, Tr_D). For additional information see FIG 3.

5. Viewing angle is the angle at which the contrast ratio is greater than 10. The angles are determined for the horizontal or x axis and the vertical or y axis with respect to the z axis which is normal to the LCD surface. For more information see FIG 4.

6. Gray scale specification

Gray Level	Luminance(%) (Typ.)
L0	0.29
L7	0.62
L15	2.44
L23	6.94
L31	16.44
L39	29.03
L47	46.66
L55	68.39
L63	100

Product Specification

FIG. 2 Luminance

<measuring point for luminance variation/surface luminance>

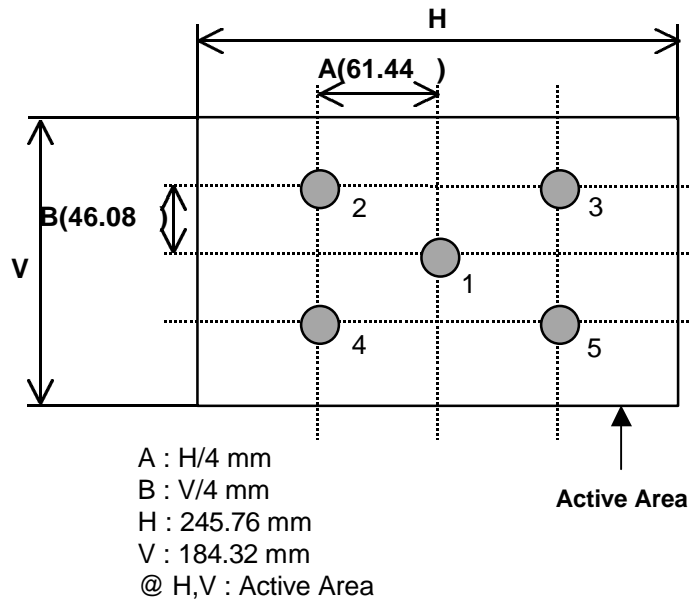
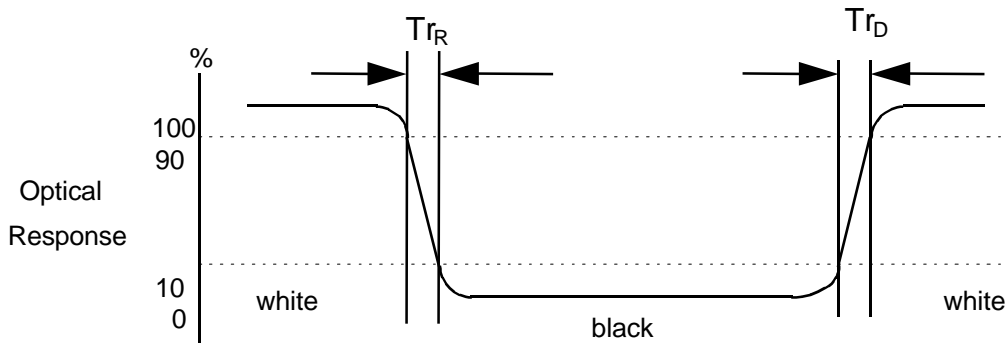

FIG. 3 Response Time

The response time is defined as the following figure and shall be measured by switching the input signal for "black" and "white".



Product Specification

FIG. 4 Viewing angle

<dimension of viewing angle range>

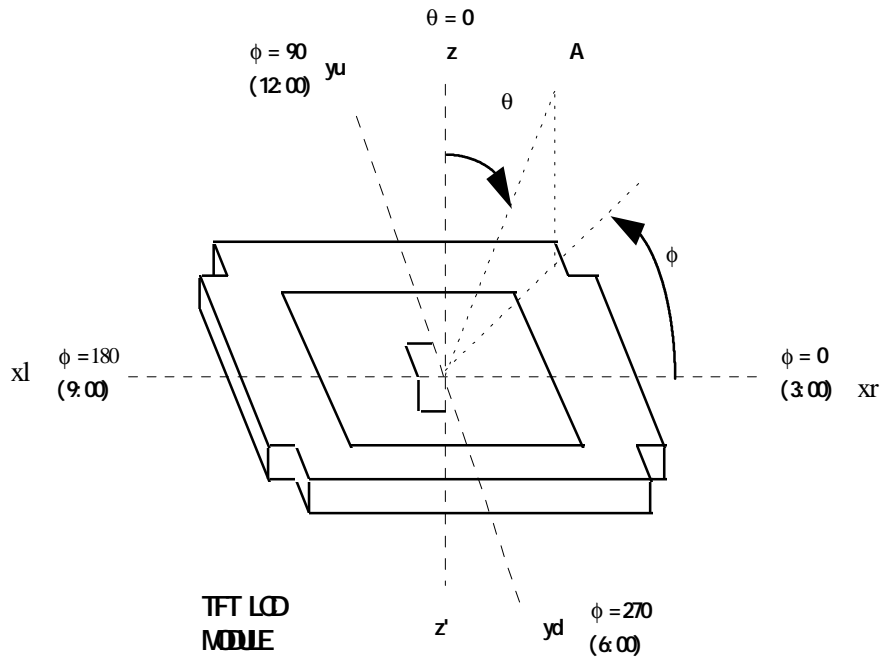

A : Eye of Observer

Product Specification

5. Mechanical Characteristics

The contents provide general mechanical characteristics for the model LP121X1-A2M1. In addition the figures in the next page are detailed mechanical drawing of the LCD.

Outside dimensions	Horizontal	261 ± 0.3mm
	Vertical	199 ± 0.5mm
	Depth	5.4 (Typ), 5.5 (Max)
Bezel area	Horizontal	250.6 ± 0.5mm
	Vertical	189.2 ± 0.5mm
Active display area	Horizontal	245.76mm
	Vertical	184.32mm
Weight(approximate)	390g(Typ.), 400g(Max.)	
Surface Treatment	Hard coating(3H) Anti-glare treatment of the front polarizer Haze(13%)	

Product Specification

<DETAIL DESCRIPTION OF SIDE MOUNTING SCREW>

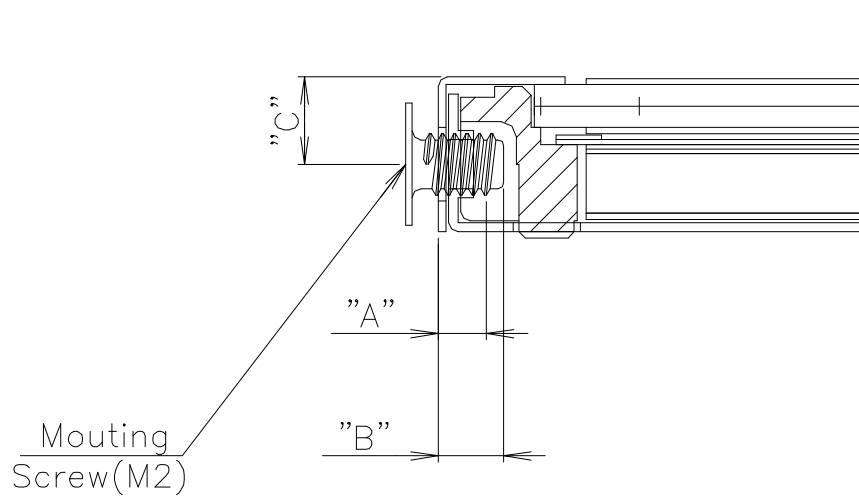

- * Mounting Screw depth
 depth Min. : "A" =1.7
 depth Max : "B" =2.2
- * Mounting screw Dim. : "C" = 2.9(typ.)
- *Torque : 1.3 ~ 1.5 kgf.cm
 (Measurement gauge : torque meter)

Notes : 1. Screw plated through the method of non-electrolytic nickel plating is preferred to reduce possibility that results in vertical and/or horizontal line defect due to the conductive particles from screw surface.

Product Specification

6. Reliability

Environment test condition

No.	Test Item	Conditions
1	High temperature storage test	Ta= 60°C 240h
2	Low temperature storage test	Ta= -20°C 240h
3	High temperature operation test	Ta= 50°C 50%RH 240h
4	Low temperature operation test	Ta= 0°C 240h
5	Vibration test (non-operating)	Sine wave, 10 ~ 500 ~ 10Hz, 1.5G, 0.37oct/min 3 axis, 1hour/axis
6	Shock test (non-operating)	Half sine wave, 180G, 2ms one shock of each six faces(I.e. run 180G 2ms for all six faces)
7	Altitude operating storage / shipment	0 - 10,000 feet(3,048m) 0 - 40,000 feet(12,192m)

{ Result Evaluation Criteria }

There should be no change which might affect the practical display function when the display quality test is conducted under normal operating condition.

Product Specification

7. International Standards

7-1. Safety

- a) UL 1950 Third Edition, Underwriters Laboratories, Inc. Jan. 28, 1995.
Standard for Safety of Information Technology Equipment Including Electrical Business Equipment.
- b) CAN/CSA C22.2 No. 950-95 Third Edition, Canadian Standards Association, Jan. 28, 1995.
Standard for Safety of Information Technology Equipment Including Electrical Business Equipment.
- c) EN 60950 : 1992+A1: 1993+A2: 1993+A3: 1995+A4: 1997+A11: 1997
IEC 950 : 1991+A1: 1992+A2: 1993+A3: 1995+A4: 1996
European Committee for Electrotechnical Standardization(CENELEC)
EUROPEAN STANDARD for Safety of Information Technology Equipment Including Electrical
Business Equipment.

7-2. EMC

- a) ANSI C63.4 "Methods of Measurement of Radio-Noise Emissions from Low-Voltage Electrical and Electrical Equipment in the Range of 9kHz to 40GHz. "American National Standards Institute(ANSI), 1992
- b) C.I.S.P.R "Limits and Methods of Measurement of Radio Interface Characteristics of Information Technology Equipment." International Special Committee on Radio Interference
- c) EN 55022 "Limits and Methods of Measurement of Radio Interface Characteristics of Information Technology Equipment." European Committee for Electrotechnical Standardization (CENELEC), 1998

Product Specification

8. Packing

8-1. Designation of Lot Mark

a) Lot Mark

A	B	C	D	E	F	G	H	I	J	K	L	M
---	---	---	---	---	---	---	---	---	---	---	---	---

A,B,C : SIZE
D : YEAR
E : MONTH
F,G : PANEL CODE
H : ASSEMBLY CODE
I,J,K,L,M : SERIAL NO.

Note:

1. YEAR

YEAR	97	98	99	2000	2001	2002	2003	2004	2005	2006	2007
Mark	7	8	9	0	1	2	3	4	5	6	7

2. MONTH

MONTH	Jan.	Feb.	Mar.	Apr.	May.	Jun.	Jul.	Aug.	Sep.	Oct.	Nov.	Dec.
Mark	1	2	3	4	5	6	7	8	9	A	B	C

b) Location of Lot Mark

Serial NO. is printed on the label. The label is attached to the backside of the LCD module.
This is subject to change without prior notice.

8-2. Packing Form

a) Package quantity in one box : 10 pcs

b) Box Size : 329mm × 278mm × 285mm

Product Specification

9. PRECAUTIONS

Please pay attention to the following when you use this TFT LCD module.

9-1. MOUNTING PRECAUTIONS

- (1) You must mount a module using holes arranged in four corners or four sides.
- (2) You should consider the mounting structure so that uneven force(ex. Twisted stress) is not applied to the module.
And the case on which a module is mounted should have sufficient strength so that external force is not transmitted directly to the module.
- (3) Please attach a transparent protective plate to the surface in order to protect the polarizer.
Transparent protective plate should have sufficient strength in order to the resist external force.
- (4) You should adopt radiation structure to satisfy the temperature specification.
- (5) Acetic acid type and chlorine type materials for the cover case are not describe because the former generates corrosive gas of attacking the polarizer at high temperature and the latter causes circuit break by electro-chemical reaction.
- (6) Do not touch, push or rub the exposed polarizers with glass, tweezers or anything harder than HB pencil lead. And please do not rub with dust clothes with chemical treatment.
Do not touch the surface of polarizer for bare hand or greasy cloth.(Some cosmetics are determined to the polarizer.)
- (7) When the surface becomes dusty, please wipe gently with absorbent cotton or other soft materials like chamois soaks with petroleum benzene. Normal-hexane is recommended for cleaning the adhesives used to attach front / rear polarizers. Do not use acetone, toluene and alcohol because they cause chemical damage to the polarizer.
- (8) Wipe off saliva or water drops as soon as possible. Their long time contact with polarizer causes deformations and color fading.
- (9) Do not open the case because inside circuits do not have sufficient strength.

9-2. OPERATING PRECAUTIONS

- (1) The spike noise causes the mis-operation of circuits. It should be lower than following voltage :
 $V = \pm 200\text{mV}$ (Over and under shoot voltage)
- (2) Response time depends on the temperature.(In lower temperature, it becomes longer.)
- (3) Brightness depends on the temperature. (In lower temperature, it becomes lower.)
And in lower temperature, response time(required time that brightness is stable after turned on) becomes longer.
- (4) Be careful for condensation at sudden temperature change. Condensation makes damage to polarizer or electrical contacted parts. And after fading condensation, smear or spot will occur.
- (5) When fixed patterns are displayed for a long time, remnant image is likely to occur.
- (6) Module has high frequency circuits. Sufficient suppression to the electromagnetic interference shall be done by system manufacturers. Grounding and shielding methods may be important to minimized the interference.

Product Specification

9-3. ELECTROSTATIC DISCHARGE CONTROL

Since a module is composed of electronic circuits, it is not strong to electrostatic discharge. Make certain that treatment persons are connected to ground through wrist band etc. And don't touch interface pin directly.

9-4. PRECAUTIONS FOR STRONG LIGHT EXPOSURE

Strong light exposure causes degradation of polarizer and color filter.

9-5. STORAGE

When storing modules as spares for a long time, the following precautions are necessary.

- (1) Store them in a dark place. Do not expose the module to sunlight or fluorescent light. Keep the temperature between 5°C and 35°C at normal humidity.
- (2) The polarizer surface should not come in contact with any other object.
It is recommended that they be stored in the container in which they were shipped.

9-6. HANDLING PRECAUTIONS FOR PROTECTION FILM

- (1) When the protection film is peeled off, static electricity is generated between the film and polarizer.
This should be peeled off slowly and carefully by people who are electrically grounded and with well ion-blown equipment or in such a condition, etc.
- (2) The protection film is attached to the polarizer with a small amount of glue. If some stress is applied to rub the protection film against the polarizer during the time you peel off the film, the glue is apt to remain on the polarizer.
Please carefully peel off the protection film without rubbing it against the polarizer.
- (3) When the module with protection film attached is stored for a long time, sometimes there remains a very small amount of glue still on the polarizer after the protection film is peeled off.
- (4) You can remove the glue easily. When the glue remains on the polarizer surface or its vestige is recognized, please wipe them off with absorbent cotton waste or other soft material like chamois soaked with normal-hexane.

Product Specification

NBPC

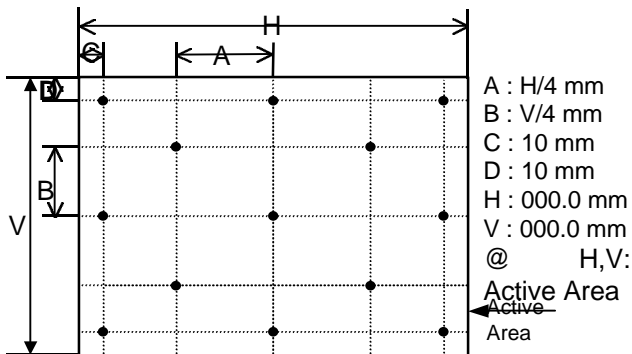
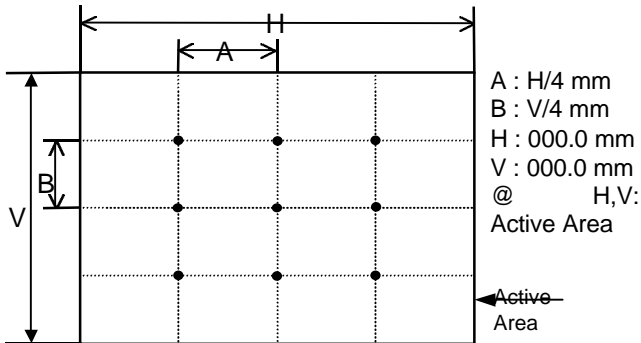
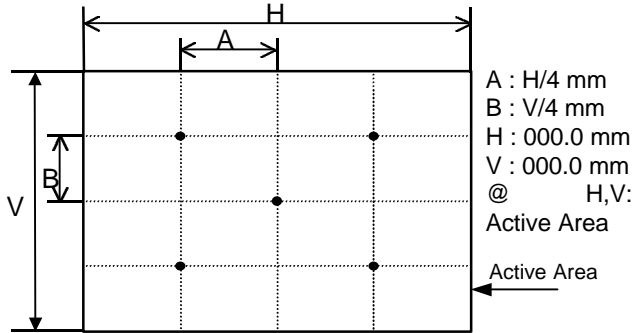

MNT

