

Product Specification
Contents

No	ITEM	Page
	COVER	1
	CONTENTS	2
	RECORD OF REVISIONS	3
1	GENERAL DESCRIPTION	4
2	ABSOLUTE MAXIMUM RATINGS	5
3	ELECTRICAL SPECIFICATIONS	6
	1) ELECTRICAL CHARACTERISTICS	6
	2) INTERFACE CONNECTIONS	8
	3) LVDS characteristics	11
	4) SIGNAL TIMING SPECIFICATIONS	14
	5) SIGNAL TIMING WAVEFORMS	15
	6) COLOR INPUT DATA REFERNECE	16
	7) POWER SEQUENCE	17
	8) POWER DIP CONDITION	18
4	OPTICAL SPECIFICATIONS	19
5	MECHANICAL CHARACTERISTICS	24
6	RELIABILITY	27
7	INTERNATIONAL STANDARDS	28
	1) SAFETY	28
	2) EMC	28
8	PACKING	29
	1) DESIGNATION OF LOT MARK	29
	2) PACKING FORM	29
9	PRECAUTIONS	30
	1) MOUNTING PRECAUTIONS	30
	2) OPERATING PRECAUTIONS	30
	3) ELECTROSTATIC DISCHARGE CONTROL	31
	4) PRECAUTIONS FOR STRONG LIGHT EXPOSURE	31
	5) STROAGE	31
	6) HANDLING PRECAUTIONS FOR PROTECTION FILM	31

Product Specification

1. General description

LM220WE5-TLC1 is a Color Active Matrix Liquid Crystal Display Light Emitting Diode (White LED) backlight system without LED driver. The matrix employs a-Si Thin Film Transistor as the active element. It is a transmissive type display operating in the normally white mode. It has a 22 inch diagonally measured active display area with WSXGA+ resolution (1050 vertical by 1680 horizontal pixel array) Each pixel is divided into Red, Green and Blue sub-pixels or dots which are arranged in vertical stripes. Gray scale or the brightness of the sub-pixel color is determined with a 8-bit gray scale signal for each dot, thus, presenting a palette of more than 16.7M colors with Advanced-FRC(Frame Rate Control). It has been designed to apply the interface method that enables low power, high speed, low EMI. FPD Link or compatible must be used as a LVDS(Low Voltage Differential Signaling) chip. It is intended to support applications where thin thickness, wide viewing angle, low power are critical factors and graphic displays are important. In combination with the vertical arrangement of the sub-pixels, the LM220WE5-TLC1 characteristics provide an excellent flat panel display for office automation products such as monitors.

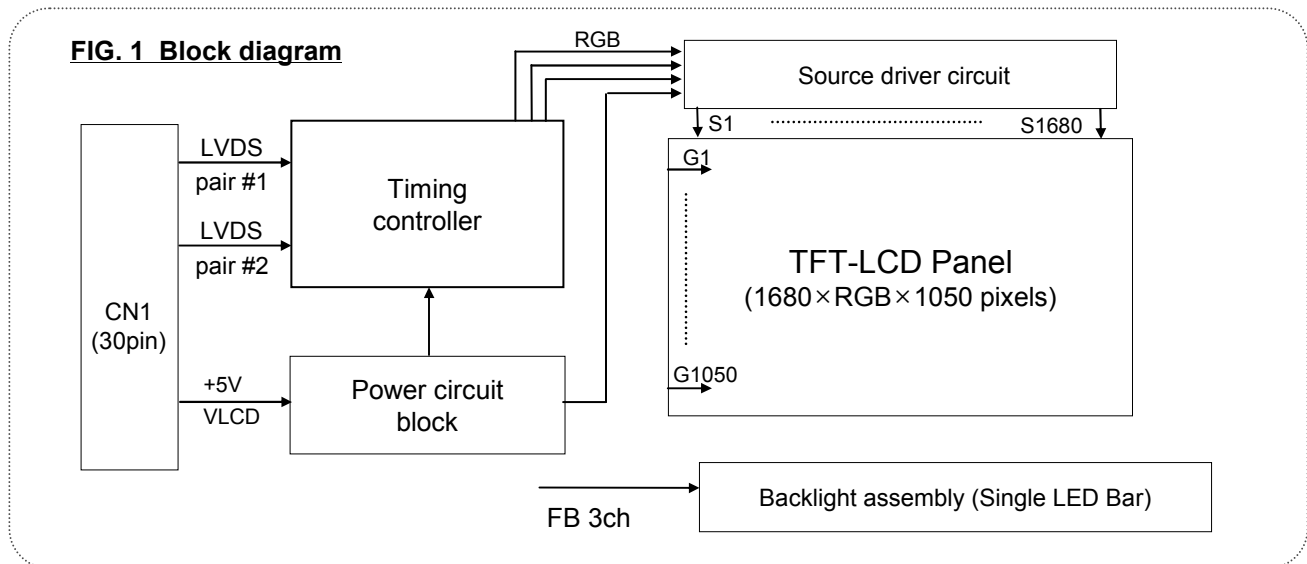

General features

Active screen size	21.995 inches(558.673mm) diagonal (Aspect ratio 16:10)
Outline Dimension	493.7(H) x 320.1 (V) x 14.5(D) mm (Typ.)
Pixel Pitch	0.282mm x 0.282mm
Pixel Format	1680 horizontal By 1050 vertical Pixels. RGB stripe arrangement
Interface	LVDS 2Port
Color depth	16.7M colors
Luminance, white	250 cd/m ² (Center 1Point, typ)
Viewing Angle (CR>10)	R/L 170(Typ.), U/D 160(Typ.)
Power Consumption	Total 18.02 Watt (Typ.), (5.25Watt @V _{LCD} , 12.77 Watt @I _s =95mA)
Weight	1850g(Typ.), 1940g(Max.)
Display operating mode	Transmissive mode, normally White
Surface treatments	Hard coating (3H), Anti-glare treatment of the front polarizer

Product Specification

2. Absolute maximum ratings

The following are maximum values which, if exceeded, may cause faulty operation or damage to the unit.

Table 1. Absolute maximum ratings

Parameter	Symbol	Values		Units	Notes
		Min	Max		
Power Supply Input Voltage	V_{LCD}	-0.3	+6.0	Vdc	At 25°C
Operating Temperature	T_{OP}	0	50	°C	1
Storage Temperature	T_{ST}	-20	60	°C	
Operating Ambient Humidity	H_{OP}	10	90	%RH	
Storage Humidity	H_{ST}	10	90	%RH	

Note : 1. Temperature and relative humidity range are shown in the figure below.
Wet bulb temperature should be 39 °C Max, and no condensation of water.

FIG. 2 Temperature and relative humidity

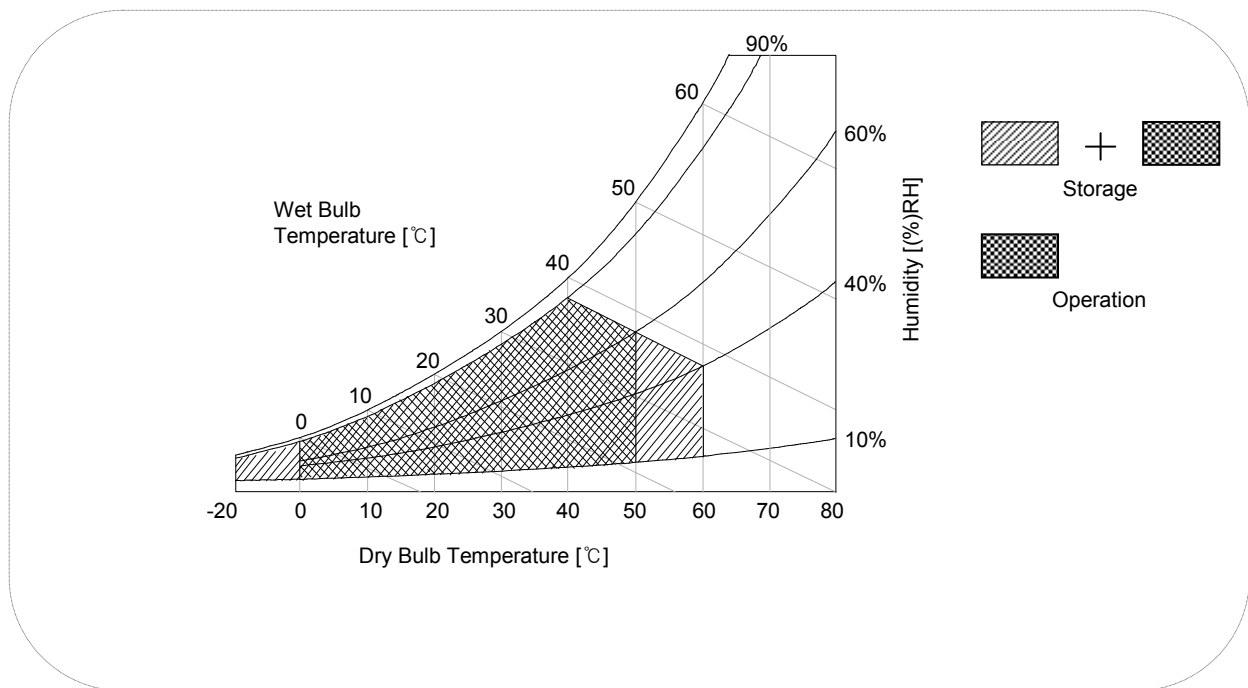

Product Specification

3. Electrical specifications

3-1. Electrical characteristics

It requires two power inputs. One is employed to power the LCD electronics and to drive the TFT array and liquid crystal. The second input power for the CCFL/Backlight, is typically generated by an inverter. The inverter is an external unit to the LCDs.

Table 2. Electrical characteristics

Parameter	Symbol	Values			Unit	Notes
		Min	Typ	Max		
MODULE :						
Power Supply Input Voltage	V_{LCD}	4.5	5.0	5.5	Vdc	
Permissive Power Input Ripple	V_{LCD}	-	-	0.2	V	3
Power Supply Input Current	$I_{LCD-MOSAIC}$	-	1050	1210	mA	1
	$I_{LCD-BLACK}$	-	1200	1380	mA	2
Power Consumption	P_{LCD}	-	5.25	6.05	Watt	1
Inrush current	I_{RUSH}	-	-	3.5	A	3

Note :

1. The specified current and power consumption are under the $V_{LCD}=5.0V$, $25 \pm 2^{\circ}C$, $f_v=60Hz$ condition whereas mosaic pattern(8 x 6) is displayed and f_v is the frame frequency.
2. The current is specified at the maximum current pattern.
3. Permissive power ripple should be measured under $VCC=5.0V$, $25^{\circ}C$, f_v (frame frequency)=75Hz condition and At that time, we recommend the bandwidth configuration of oscilloscope is to be under 20MHz.
4. The duration of rush current is about 2ms and rising time of power Input is $500us \pm 20\%$.

FIG.3 pattern for Electrical characteristics

power consumption measurement

White : 255Gray
Black : 0Gray

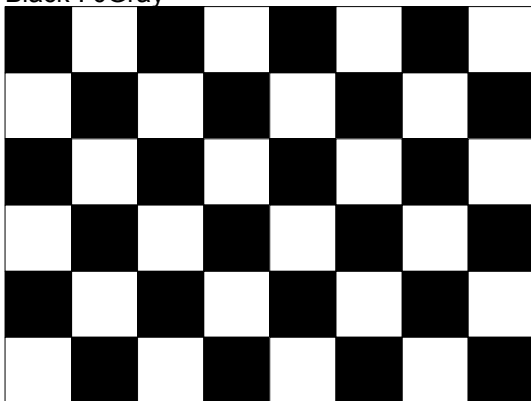

Mosaic Pattern(8 x 6)

power input ripple

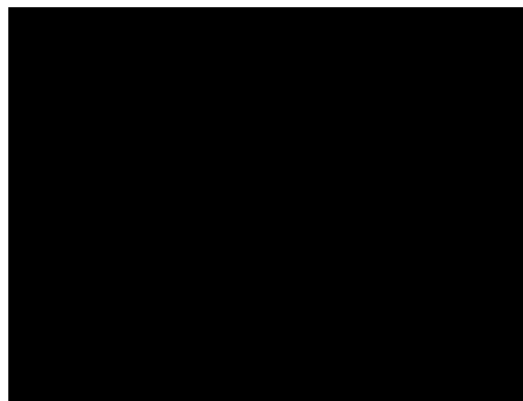

Full Black Pattern

Product Specification
Table 3. LED bar Electrical characteristics

Parameter	Symbol	Condition	Values			Unit	Notes
			Min.	Typ.	Max.		
LED :							1,7
LED String Current	Is_peak		-	95	105	mA	2,7
LED String Voltage	Vs		42.0	44.8	47.6	V	3,7
Power Consumption	PBar		11.97	12.77	13.57	Watt	4,6,7
LED Life Time	LED_LT		30,000	-	-	Hrs	5,7

LED driver design guide

: The design of the LED driver must have specifications for the LED in LCD Assembly.

The performance of the LED in LCM, for example life time or brightness, is extremely influenced by the characteristics of the LED driver.

So all the parameters of an LED driver should be carefully designed and output current should be Constant current control.

Please control feedback current of each string individually to compensate the current variation among the strings of LEDs.

When you design or order the LED driver, please make sure unwanted lighting caused by the mismatch of the LED and the LED driver (no lighting, flicker, etc) never occurs.

When you confirm it, the LCD module should be operated in the same condition as installed in your instrument.

- Specified values are for a single LED bar.
- The specified current is input LED chip 100% duty current.
- The specified voltage is input LED string and Bar voltage at typical 95mA 100% duty current.
- The specified power consumption is input LED bar power consumption at typical 95mA 100% duty current.
- The life is determined as the time at which luminance of the LED is 50% compared to that of initial value at the typical LED current on condition of continuous operating at $25 \pm 2^{\circ}\text{C}$.
- The LED bar power consumption shown above does not include loss of external driver.
The used LED bar current is the LED typical current.
Min Power Consumption is calculated with $P_{\text{Bar}} = V_{\text{s}}(\text{Min.}) \times I_{\text{s}}(\text{Typ.}) \times N_{\text{string}}$
Max Power Consumption is calculated with $P_{\text{Bar}} = V_{\text{bar}}(\text{Max.}) \times I_{\text{s}}(\text{Typ.}) \times N_{\text{string}}$
- LED operating DC Forward Current and Junction Temperature must not exceed LED Max Ratings at $25 \pm 2^{\circ}\text{C}$.

Product Specification
3-2. Interface connections

LCD connector(CN1) : GT103-30S-H23 (LSM) , IS100-L30B-C23 (UJU)

Mating connector : FI-X30H and FI-X30HL (JAE) or Equivalent

Table 4. Module connector(CN1) pin configuration

Pin No	Symbol	Description
1	RX00-	Minus signal of 1st channel 0 (LVDS)
2	RX00+	Plus signal of 1st channel 0 (LVDS)
3	RX01-	Minus signal of 1st channel 1 (LVDS)
4	RX01+	Plus signal of 1st channel 1 (LVDS)
5	RX02-	Minus signal of 1st channel 2 (LVDS)
6	RX02+	Plus signal of 1st channel 2 (LVDS)
7	GND	Ground
8	RXOC-	Minus signal of 1st clock channel (LVDS)
9	RXOC+	Plus signal of 1st clock channel (LVDS)
10	RX03-	Minus signal of 1st channel 3 (LVDS)
11	RX03+	Plus signal of 1st channel 3 (LVDS)
12	RXE0-	Minus signal of 2nd channel 0 (LVDS)
13	RXE0+	Plus signal of 2nd channel 0 (LVDS)
14	GND	Ground
15	RXE1-	Minus signal of 2nd channel 1 (LVDS)
16	RXE1+	Plus signal of 2nd channel 1 (LVDS)
17	GND	Ground
18	RXE2-	Minus signal of 2nd channel 2 (LVDS)
19	RXE2+	Plus signal of 2nd channel 2 (LVDS)
20	RXEC-	Minus signal of 2nd clock channel (LVDS)
21	RXEC+	Plus signal of 2nd clock channel (LVDS)
22	RXE3-	Minus signal of 2nd channel 3 (LVDS)
23	RXE3+	Plus signal of 2nd channel 3 (LVDS)
24	GND	Ground
25	NC	No Connection (For LCD internal use only.)
26	NC	No Connection (For LCD internal use only.)
27	PWM_OUT	Reference signal for burst frequency inverter control
28	V _{LCD}	Power Supply (5.0V)
29	V _{LCD}	Power Supply (5.0V)
30	V _{LCD}	Power Supply (5.0V)

First Pixel data

Second Pixel data

Product Specification

FIG. 4 Connector diagram

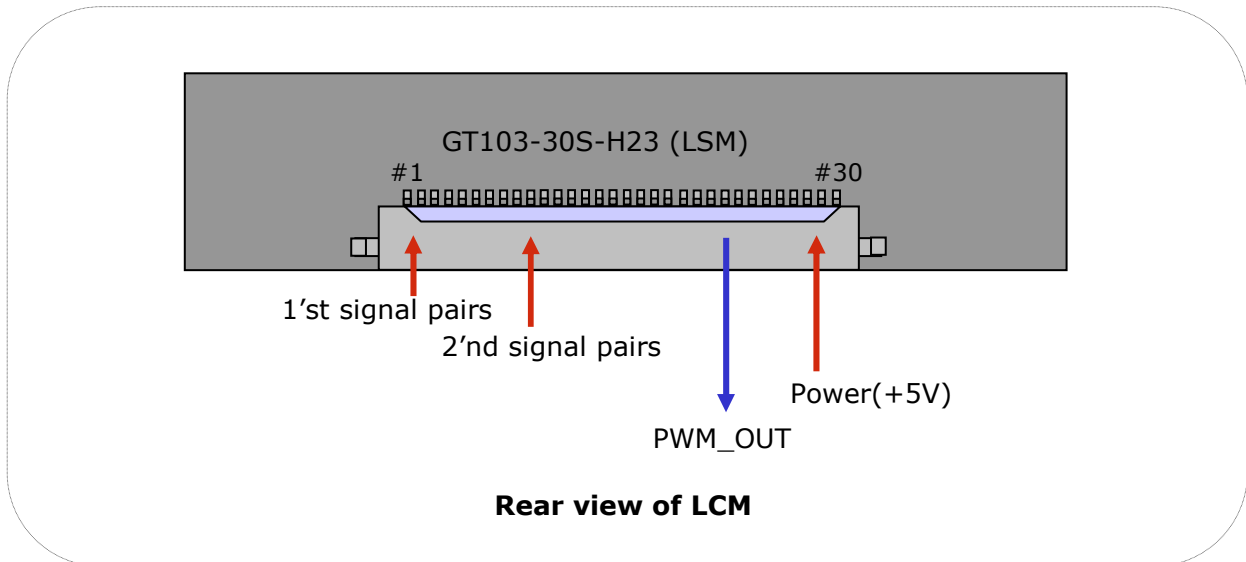

Note:

1. NC: No Connection.
2. All GND(ground) pins should be connected together and to Vss which should also be connected to the LCD's metal frame.
3. All V_{LCD} (power input) pins should be connected together.
4. Input Level of LVDS signal is based on the IEA 664 Standard.
5. PWM_OUT is a reference signal for inverter control.
 This PWM signal is synchronized with vertical frequency.
 Its frequency is 3 times of vertical frequency, and its duty ratio is 50%.
 If the system don't use this pin, do not connect.

Product Specification

The LED interface connector is a model 05010HR-06D manufactured by YEONHO.
The mating connector part number are 05010HR-06D or equivalent.
The pin configuration for the connector is shown in the table below.

Table 5. LED connector pin configuration

Pin	Symbol	Description	Notes
1	FB1	Channel1 Current Feed Back	
2	FB2	Channel2 Current Feed Back	
3	Vled1	LED Power Supply	
4	Vled1	LED Power Supply	
5	NC	NC	
6	FB3	Channel3 Current Feed Back	

FIG. 5 Backlight connector view

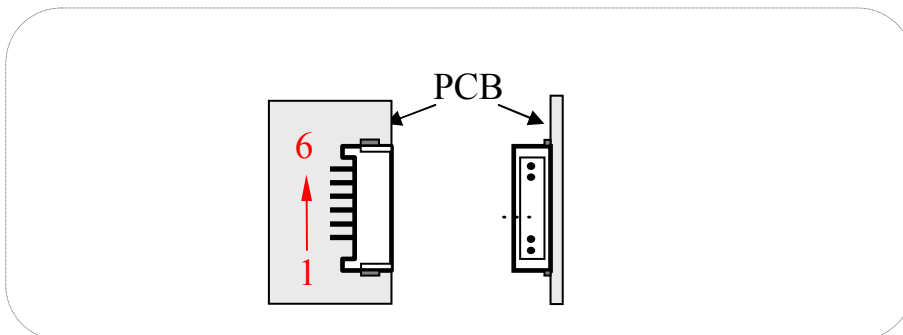

Product Specification
Table 6. Required signal assignment for Flat Link(NS:DS90CF383) transmitter

Pin #	Pin Name	Require Signal	Pin #	Pin Name	Require Signal
1	VCC	Power Supply for TTL Input	29	GND	Ground pin for TTL
2	D5	TTL Input (R7)	30	D26	TTL Input (DE)
3	D6	TTL Input (R5)	31	T _x CLKIN	TTL Level clock Input
4	D7	TTL Input (G0)	32	PWR DWN	Power Down Input
5	GND	Ground pin for TTL	33	PLL GND	Ground pin for PLL
6	D8	TTL Input (G1)	34	PLL VCC	Power Supply for PLL
7	D9	TTL Input (G2)	35	PLL GND	Ground pin for PLL
8	D10	TTL Input (G6)	36	LVDS GND	Ground pin for LVDS
9	VCC	Power Supply for TTL Input	37	T _x OUT3 +	Positive LVDS differential data output 3
10	D11	TTL Input (G7)	38	T _x OUT3 –	Negative LVDS differential data output 3
11	D12	TTL Input (G3)	39	T _x CLKOUT +	Positive LVDS differential clock output
12	D13	TTL Input (G4)	40	T _x CLKOUT –	Negative LVDS differential clock output
13	GND	Ground pin for TTL	41	T _x OUT2 +	Positive LVDS differential data output 2
14	D14	TTL Input (G5)	42	T _x OUT2 –	Negative LVDS differential data output 2
15	D15	TTL Input (B0)	43	LVDS GND	Ground pin for LVDS
16	D16	TTL Input (B6)	44	LVDS VCC	Power Supply for LVDS
17	VCC	Power Supply for TTL Input	45	T _x OUT1 +	Positive LVDS differential data output 1
18	D17	TTL Input (B7)	46	T _x OUT1 –	Negative LVDS differential data output 1
19	D18	TTL Input (B1)	47	T _x OUT0 +	Positive LVDS differential data output 0
20	D19	TTL Input (B2)	48	T _x OUT0 –	Negative LVDS differential data output 0
21	GND	Ground pin for TTL Input	49	LVDS GND	Ground pin for LVDS
22	D20	TTL Input (B3)	50	D27	TTL Input (R6)
23	D21	TTL Input (B4)	51	D0	TTL Input (R0)
24	D22	TTL Input (B5)	52	D1	TTL Input (R1)
25	D23	TTL Input (RSVD)	53	GND	Ground pin for TTL
26	VCC	Power Supply for TTL Input	54	D2	TTL Input (R2)
27	D24	TTL Input (HSYNC)	55	D3	TTL Input (R3)
28	D25	TTL Input (VSYNC)	56	D4	TTL Input (R4)

Notes : 1. Refer to LVDS Transmitter Data Sheet for detail descriptions.
 2. 7 means MSB and 0 means LSB at R,G,B pixel data

Product Specification
3-4. Signal timing specifications

This is the signal timing required at the input of the User connector. All of the interface signal timing should be satisfied with the following specifications for its proper operation.

Table 7. Timing table

Parameter		Symbol	Min.	Typ.	Max.	Unit	Notes
D _{CLK}	Period	t _{CLK}	13.4	16.8	20.1	ns	Pixel frequency : Typ.119MHz
	Frequency	f _{CLK}	49.7	59.6	74.5	MHz	
Horizontal	Horizontal Valid	t _{HV}	840	840	840	t _{CLK}	
	H Period Total	t _{HP}	904	920	1200		
	Hsync Frequency	f _H	54.0	64.8	81.0	kHz	
Vertical	Vertical Valid	t _{VV}	1050	1050	1050	t _{HP}	
	V Period Total	t _{VP}	1060	1080	1300		
	Vsync Frequency	f _V	50	60	75	Hz	
DE (Data Enable)	DE Setup Time	t _{SI}	4	-	-	ns	For D _{CLK}
	DE Hold Time	t _{HI}	4	-	-		
Data	Data Setup Time	t _{SD}	4	-	-	ns	For D _{CLK}
	Data Hold Time	t _{HD}	4	-	-		

Note:

1. DE Only mode operation. The input of Hsync & Vsync signal does not have an effect on LCD normal operation.
2. The performance of the electro-optical characteristics may be influenced by variance of the vertical refresh rates.
3. Horizontal period should be even.

3-5. Signal timing waveforms

1. D_{CLK}, DE, DATA waveforms

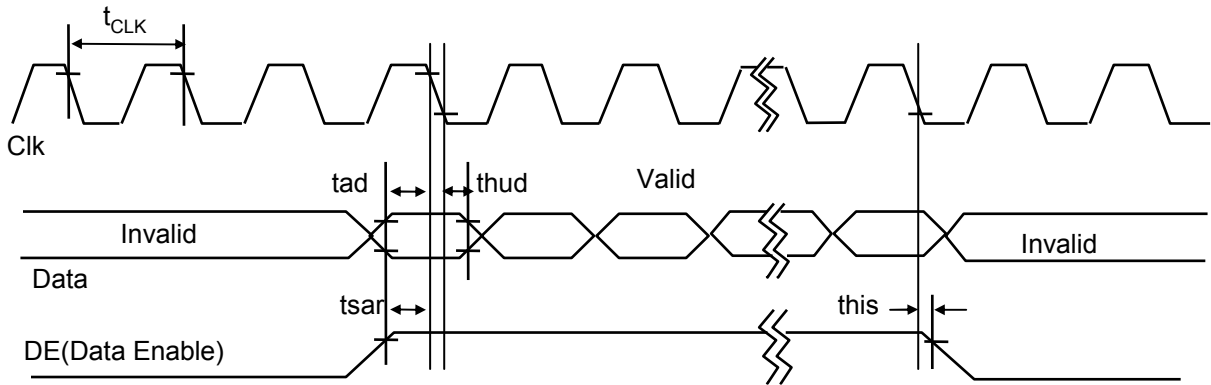

2. Horizontal waveform

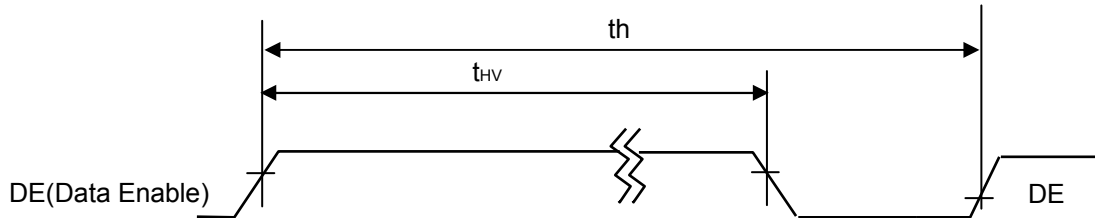

3. Vertical waveform

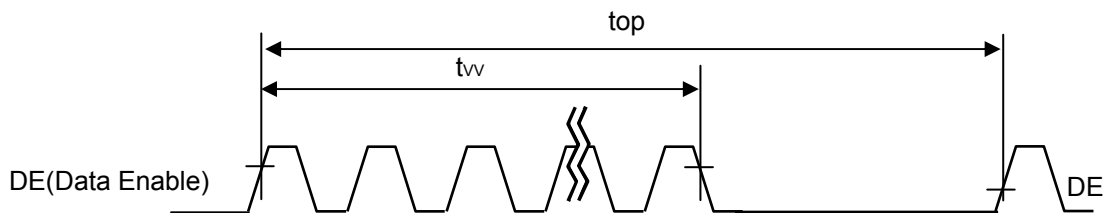

Product Specification
3-6. Color input data reference

The brightness of each primary color (red, green and blue) is based on the 8bit gray scale data input for the color ; the higher the binary input, the brighter the color. The table below provides a reference for color versus data input.

Table 8. Color data reference

Color		Input Color Data																							
		Red								Green								Blue							
		MSB				LSB				MSB				LSB				MSB				LSB			
		R7	R6	R5	R4	R3	R2	R1	R0	G7	G6	G5	G4	G3	G2	G1	G0	B7	B6	B5	B4	B3	B2	B1	B0
Basic Color	Black	0	0	0	0	0	0	0	0	0	0	0	0	0	0	0	0	0	0	0	0	0	0	0	0
	Red (255)	1	1	1	1	1	1	1	1	0	0	0	0	0	0	0	0	0	0	0	0	0	0	0	0
	Green (255)	0	0	0	0	0	0	0	0	1	1	1	1	1	1	1	1	0	0	0	0	0	0	0	0
	Blue (255)	0	0	0	0	0	0	0	0	0	0	0	0	0	0	0	0	1	1	1	1	1	1	1	1
	Cyan	0	0	0	0	0	0	0	0	1	1	1	1	1	1	1	1	1	1	1	1	1	1	1	1
	Magenta	1	1	1	1	1	1	1	1	0	0	0	0	0	0	0	0	1	1	1	1	1	1	1	1
	Yellow	1	1	1	1	1	1	1	1	1	1	1	1	1	1	1	1	0	0	0	0	0	0	0	0
	White	1	1	1	1	1	1	1	1	1	1	1	1	1	1	1	1	1	1	1	1	1	1	1	1
Red	Red(000) Dark	0	0	0	0	0	0	0	0	0	0	0	0	0	0	0	0	0	0	0	0	0	0	0	0
	Red(001)	0	0	0	0	0	0	0	1	0	0	0	0	0	0	0	0	0	0	0	0	0	0	0	0
	Red(002)	0	0	0	0	0	0	1	0	0	0	0	0	0	0	0	0	0	0	0	0	0	0	0	0
	-----	-	-	-	-	-	-	-	-	-	-	-	-	-	-	-	-	-	-	-	-	-	-	-	-
	-----	-	-	-	-	-	-	-	-	-	-	-	-	-	-	-	-	-	-	-	-	-	-	-	-
	Red(253)	1	1	1	1	1	1	0	1	0	0	0	0	0	0	0	0	0	0	0	0	0	0	0	0
	Red(254)	1	1	1	1	1	1	1	0	0	0	0	0	0	0	0	0	0	0	0	0	0	0	0	0
	Red(255) Bright	1	1	1	1	1	1	1	1	0	0	0	0	0	0	0	0	0	0	0	0	0	0	0	0
Green	Green(000) Dark	0	0	0	0	0	0	0	0	0	0	0	0	0	0	0	0	0	0	0	0	0	0	0	0
	Green(001)	0	0	0	0	0	0	0	0	0	0	0	0	0	0	1	0	0	0	0	0	0	0	0	0
	Green(002)	0	0	0	0	0	0	0	0	0	0	0	0	0	1	0	0	0	0	0	0	0	0	0	0
	-----	-	-	-	-	-	-	-	-	-	-	-	-	-	-	-	-	-	-	-	-	-	-	-	-
	-----	-	-	-	-	-	-	-	-	-	-	-	-	-	-	-	-	-	-	-	-	-	-	-	-
	Green(253)	0	0	0	0	0	0	0	1	1	1	1	1	1	1	0	1	0	0	0	0	0	0	0	0
	Green(254)	0	0	0	0	0	0	0	1	1	1	1	1	1	1	1	0	0	0	0	0	0	0	0	0
	Green(255)Bright	0	0	0	0	0	0	0	1	1	1	1	1	1	1	1	1	0	0	0	0	0	0	0	0
Blue	Blue(000) Dark	0	0	0	0	0	0	0	0	0	0	0	0	0	0	0	0	0	0	0	0	0	0	0	0
	Blue(001)	0	0	0	0	0	0	0	0	0	0	0	0	0	0	0	0	0	0	0	0	0	0	0	1
	Blue(002)	0	0	0	0	0	0	0	0	0	0	0	0	0	0	0	0	0	0	0	0	0	0	1	0
	-----	-	-	-	-	-	-	-	-	-	-	-	-	-	-	-	-	-	-	-	-	-	-	-	-
	-----	-	-	-	-	-	-	-	-	-	-	-	-	-	-	-	-	-	-	-	-	-	-	-	-
	Blue(253)	0	0	0	0	0	0	0	0	0	0	0	0	0	0	0	1	1	1	1	1	1	1	0	1
	Blue(254)	0	0	0	0	0	0	0	0	0	0	0	0	0	0	0	1	1	1	1	1	1	1	1	0
	Blue(255) Bright	0	0	0	0	0	0	0	0	0	0	0	0	0	0	0	1	1	1	1	1	1	1	1	1

Product Specification

3-7. Power sequence

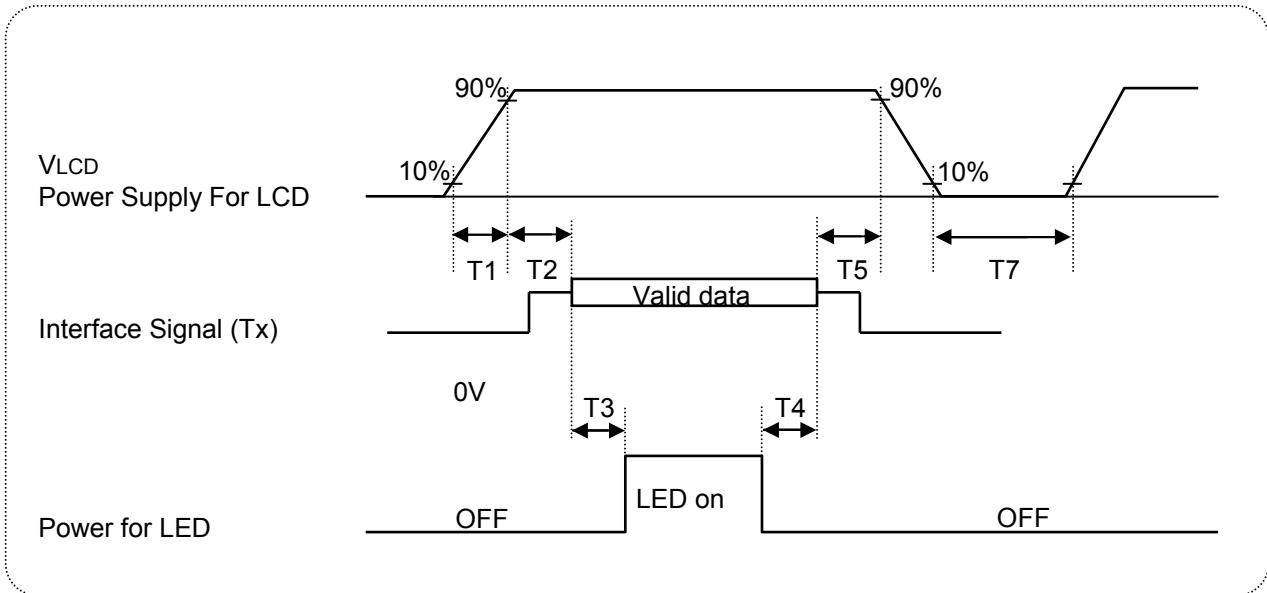

Table 9. Power sequence

Parameter	Values			Units
	Min	Typ	Max	
T1	0.5	-	10	ms
T2	0.01	-	50	ms
T3	500	-	-	ms
T4	200	-	-	ms
T5	0.01	-	50	ms
T7	1	-	-	s

Notes :

1. Please V_{LCD} power on only after connecting interface cable to LCD.
2. Please avoid floating state of interface signal at invalid period.
3. When the interface signal is invalid, be sure to pull down the power supply for LCD V_{LCD} to 0V.
4. LED power must be turn on after power supply for LCD an interface signal are valid.

3-8. V_{LCD} Power dip condition

FIG. 6 Power dip condition

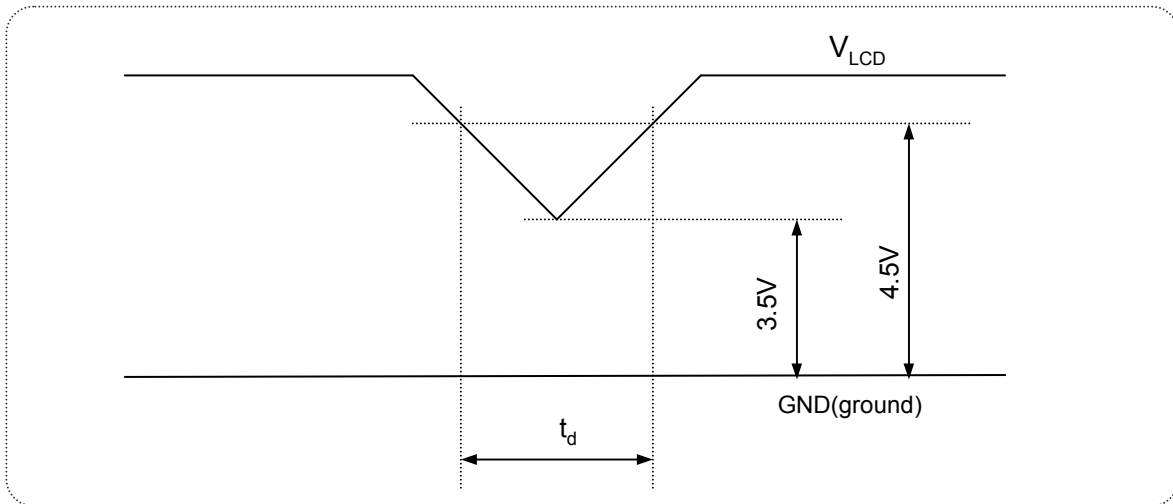

1) Dip condition

$$3.5V \leq V_{LCD} < 4.5V, t_d \leq 20ms$$

2) $V_{LCD} < 3.5V$

V_{LCD} -dip conditions should also follow the Power On/Off conditions for supply voltage.

Product Specification

4. Optical specification

Optical characteristics are determined after the unit has been 'ON' for 30 minutes in a dark environment at 25°C. The values specified are at an approximate distance 50cm from the LCD surface at a viewing angle of Φ and θ equal to 0°.

FIG. 7 presents additional information concerning the measurement equipment and method.

FIG. 7 Optical characteristic measurement equipment and method

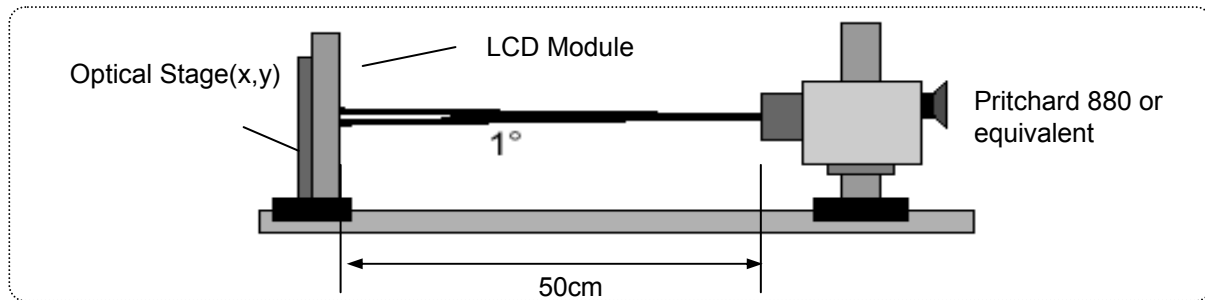

Table 10. Optical characteristics

Ta= 25°C, V_{LCD}=5.0V, fv=60Hz f_{CLK}=119MHz

Parameter	Symbol	Values			Units	Notes	
		Min	Typ	Max			
Contrast Ratio	CR	700	1000	-		1	
Surface Luminance, white	L _{WH}	200	250	-	cd/m ²	2	
Luminance Variation	δ_{WHITE} 9P	75			%	3	
Response Time	Rise Time	Tr _R	-	1.3	2.6	ms	4
	Decay Time	Tr _D	-	3.7	7.4	ms	4
Color Coordinates [CIE1931]	RED	Rx	Typ -0.03	0.628	Typ +0.03		
		Ry		0.348			
	GREEN	Gx		0.345			
		Gy		0.615			
	BLUE	Bx		0.153			
		By		0.057			
	WHITE	Wx		0.313			
		Wy		0.329			
Viewing Angle (CR>5)							
	x axis, right($\phi=0^\circ$)	θ_r	75	88		Degree	5
	x axis, left ($\phi=180^\circ$)	θ_l	75	88			
	y axis, up ($\phi=90^\circ$)	θ_u	70	85			
	y axis, down ($\phi=270^\circ$)	θ_d	70	85			
Viewing Angle (CR>10)							
	x axis, right($\phi=0^\circ$)	θ_r	70	85		Degree	5
	x axis, left ($\phi=180^\circ$)	θ_l	70	85			
	y axis, up ($\phi=90^\circ$)	θ_u	60	75			
	y axis, down ($\phi=270^\circ$)	θ_d	70	85			
Crosstalk				1.5	%	8	
Luminance uniformity - Angular dependence (TCO'03)	LR	-	-	1.7		6	

Product Specification

Notes :

1. Contrast ratio(CR) is defined mathematically as :It is measured at center point(1)

$$\text{Contrast ratio} = \frac{\text{Surface luminance with all white pixels}}{\text{Surface luminance with all black pixels}}$$

2. Surface luminance is the luminance value at center 1 point(1) across the LCD surface 50cm from the surface with all pixels displaying white. For more information see FIG 8.

3. The variation in surface luminance , δ_{WHITE} is defined as

$$\delta_{\text{WHITE}} = \frac{\text{Minimum (P1,P2P9)}}{\text{Maximum (P1,P2P9)}} * 100$$

For more information see Figure 8.

FIG. 8 Luminance measuring point

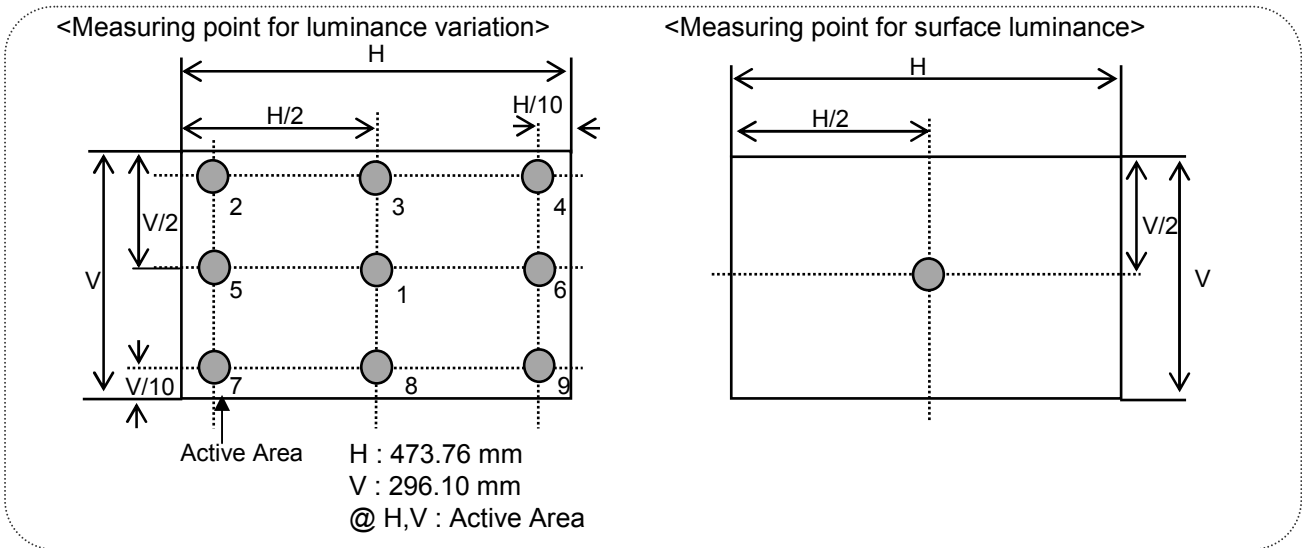

Product Specification

Notes :

- 4. Response time is the time required for the display to transition from black to white (Decay Time, T_{rD}) and from white to black (Rise Time, T_{rR})
The sampling rate is 2,500 sample/sec. For additional information see FIG. 9.

The response time is defined as the following figure and shall be measured by switching the input signal for each gray to gray.

FIG. 9 Response time

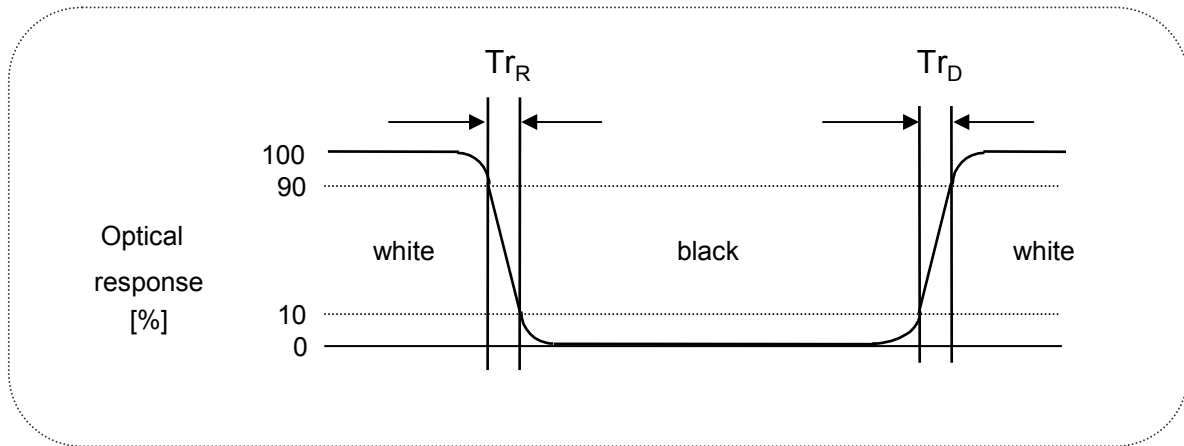

- 5. Viewing angle is the angle at which the contrast ratio is greater than 10 or 5. The angles are determined for the horizontal or x axis and the vertical or y axis with respect to the z axis which is normal to the LCD surface. For more information see FIG. 10 .

FIG. 10 Viewing angle

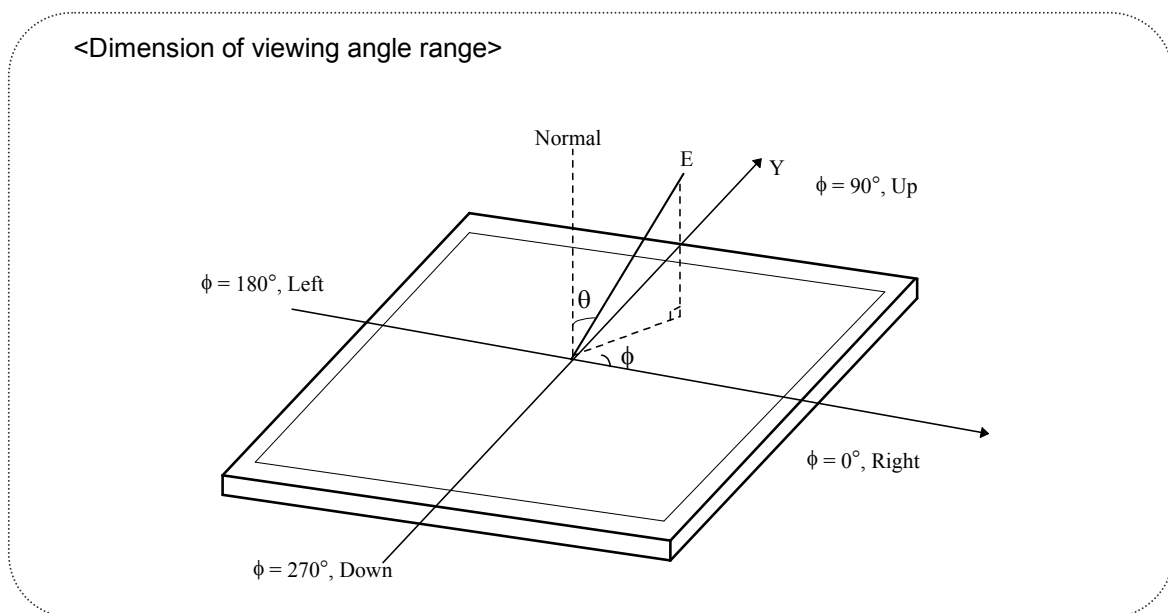

Product Specification

Notes :

6. Luminance Uniformity - angular – dependence (LR & TB)

TCO '03 Luminance uniformity – angular dependence, is the capacity of the VDU to present the same Luminance level independently of the viewing direction. The angular-dependent luminance uniformity is calculated as the ratio of maximum luminance to minimum luminance in the specified measurement areas.

- Test pattern : 80% white pattern
- Test point : 2-point
- Test distance : $D * 1.5 = 83.82\text{cm}$
- Test method : $L_R = ((L_{\text{max.}+30\text{deg.}} / L_{\text{min.}+30\text{deg.}}) + (L_{\text{max.}-30\text{deg.}} / L_{\text{min.}-30\text{deg.}})) / 2$
 $T_B = (L_{\text{max.}+15\text{deg.}} / L_{\text{min.}+15\text{deg.}})$

FIG. 11 Luminance Uniformity angular dependence

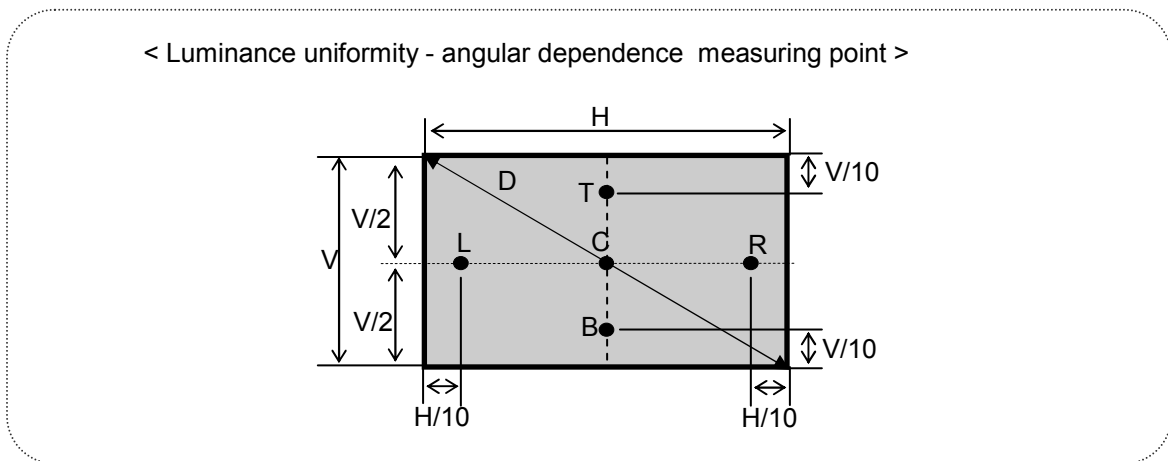

7. Gray scale specification

Table 11. Gray scale

Gray level	Luminance [%] (Typ)
L0	0.1
L31	1.23
L63	4.98
L95	12.30
L127	23.58
L159	40.03
L191	61.30
L223	84.03
L255	100

Product Specification

Notes :

8. The equation of crosstalk : $(|L_{A[or\ C]2} - L_{A[or\ C]1}| / L_{A[or\ C]1}) \times 100(\%)$ [Vertical],
 $(|L_{B[or\ D]2} - L_{B[or\ D]1}| / L_{B[or\ D]1}) \times 100(\%)$ [Horizontal]

FIG. 12 Crosstalk

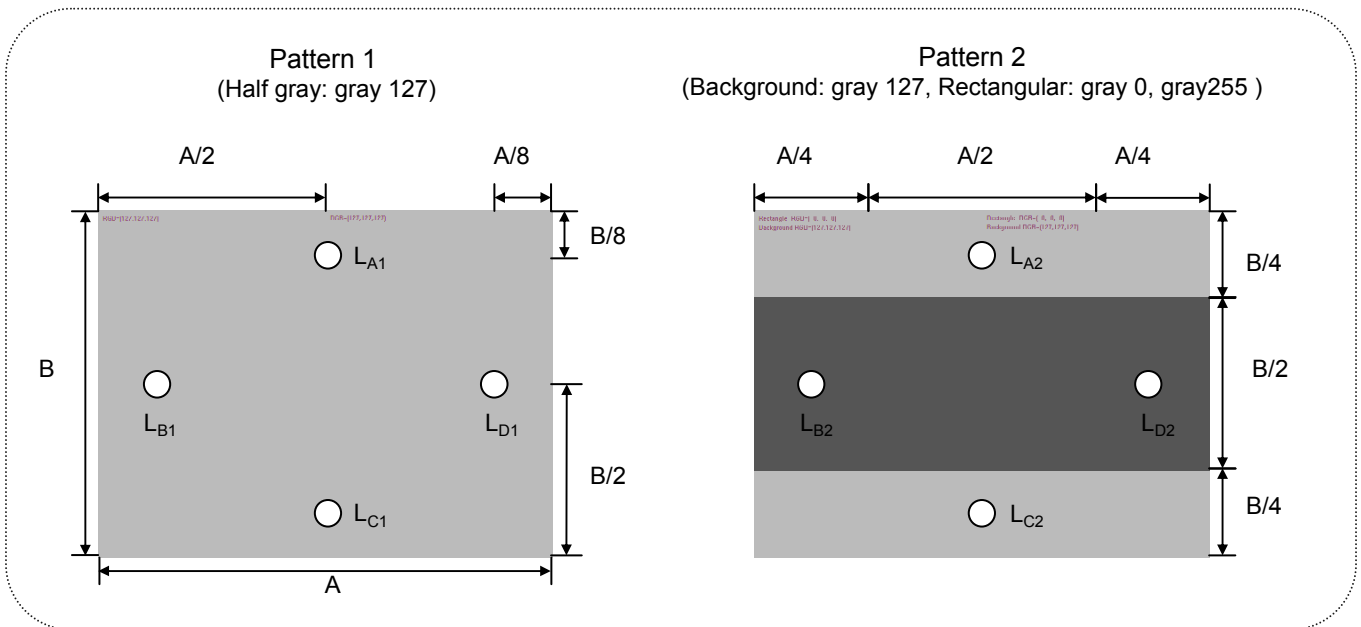

Product Specification

5. Mechanical characteristics

The contents provide general mechanical characteristics. In addition the figures in the next page are detailed mechanical drawing of the LCD.

Table 12. Mechanical characteristics

Outline dimension	Horizontal	493.7 mm
	Vertical	320.1 mm
	Depth	14.5 mm
Bezel area	Horizontal	477.7 mm
	Vertical	300.1 mm
Active display area	Horizontal	473.76 mm
	Vertical	296.10 mm
Weight	1,850g (Typ.), 1940g (Max.)	
Surface treatment	Hard coating(3H) Anti-glare treatment of the front polarizer	

Notes : Please refer to a mechanic drawing in terms of tolerance at the next page.

Product Specification

< FRONT VIEW >

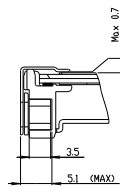
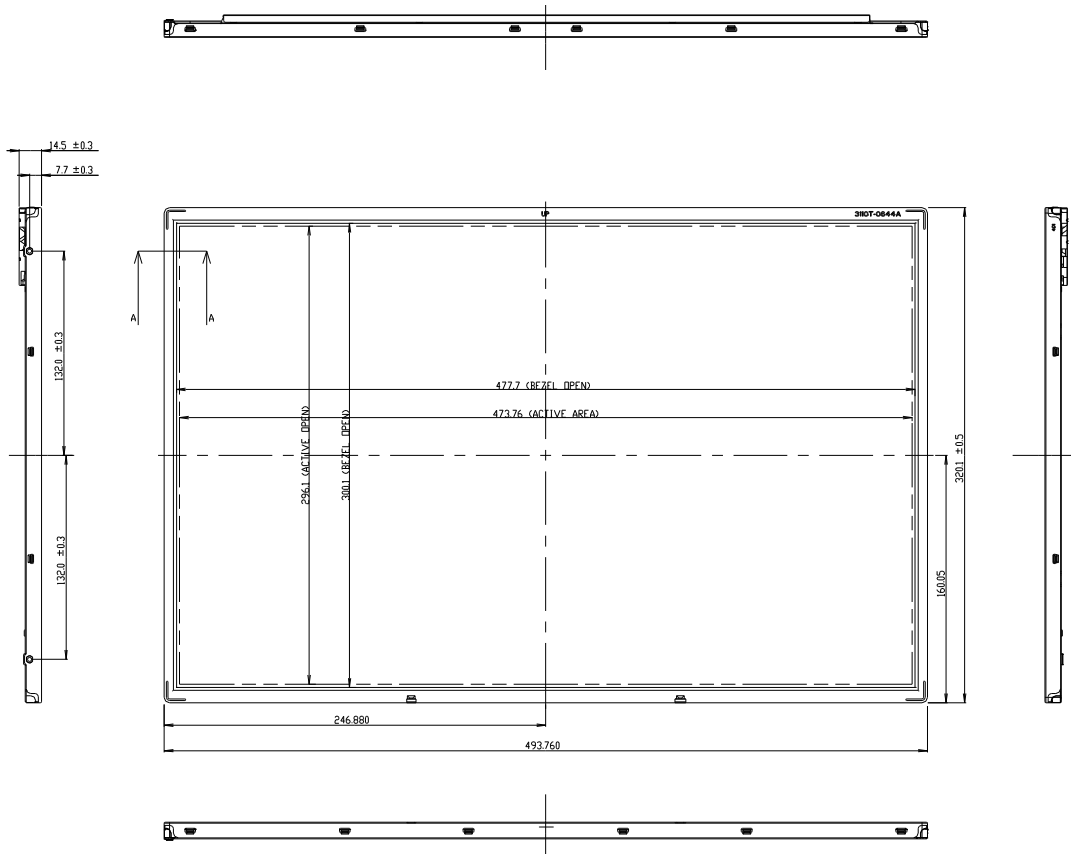

Product Specification

< REAR VIEW >

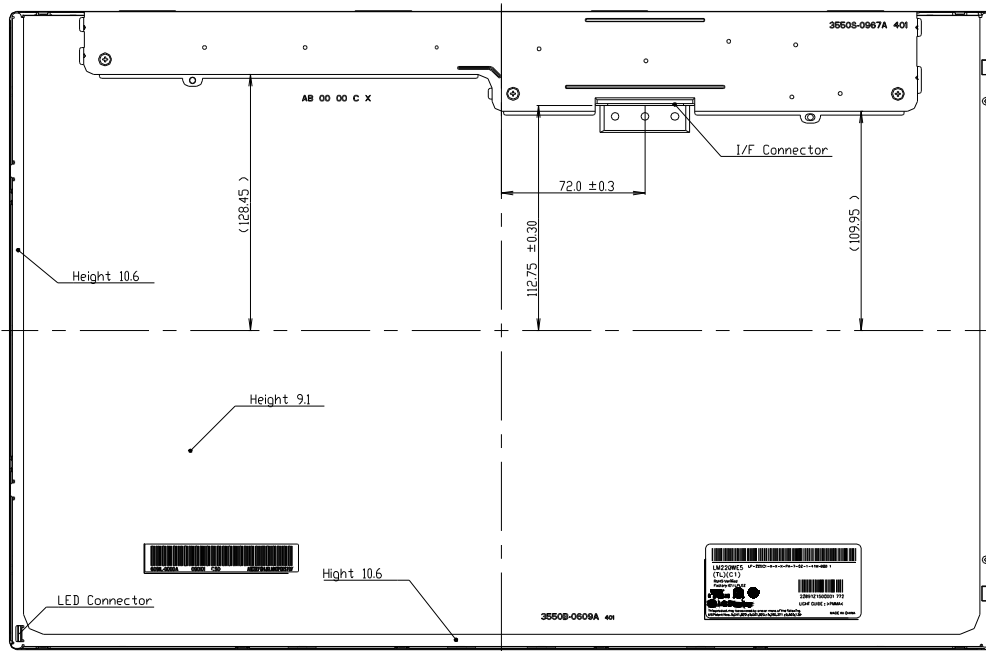

Notes

1. Backlight has 1 LED PKG ASS'Y.
2. I/F Connector Specification
 - 187024-30091(P-TWO), IS100-L30B-C23(UJU)
3. LED Connector Specification
 - 05010HR-06D (Yeonho) or Equivalent.
4. Torque of user hole : 3.0~3.5 kgf-cm
5. Tilt and partial disposition tolerance of display area as following
 - (1) Y-Direction : $IA-BI \leq 1.0$
 - (2) X-Direction : $IC-DI \leq 1.0$

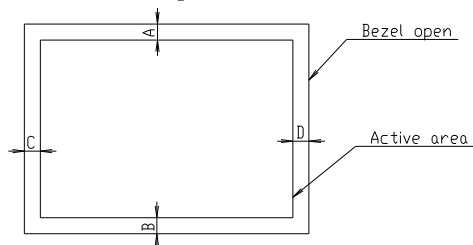

6. Unspecified tolerances to be $\pm 0.5\text{mm}$

Product Specification
6. Reliability
Table 13. Environment test conditions

No	Test Item	Condition
1	High temperature storage test	Ta= 60°C 240hrs
2	Low temperature storage test	Ta= -20°C 240hrs
3	High temperature operation test	Ta= 50°C 50%RH 240hrs
4	Low temperature operation test	Ta= 0°C 240hrs
5	Vibration test (non-operating)	Wave form : random Vibration level : 1.0GRMS Bandwidth : 10-300Hz Duration : X,Y,Z, 20 min One time each direction
6	Shock test (non-operating)	Shock level : 120G Waveform : half sine wave, 2msec Direction : ±X, ±Y, ±Z One time each direction
7	Altitude operating storage / shipment	0 - 10,000 feet(3,048m) 0 - 40,000 feet(12,192m)

{ Result evaluation criteria }

There should be no change which might affect the practical display function when the display quality test is conducted under normal operating condition.

Product Specification

7. International standards

7-1. Safety

- a) UL 60950-1, Second Edition, Underwriters Laboratories Inc.
Information Technology Equipment - Safety - Part 1 : General Requirements.
- b) CAN/CSA C22.2 No.60950-1-07, Second Edition, Canadian Standards Association.
Information Technology Equipment - Safety - Part 1 : General Requirements.
- c) EN 60950-1:2006 + A11:2009, European Committee for Electrotechnical Standardization(CENELEC).
Information Technology Equipment - Safety - Part 1 : General Requirements.
- d) IEC 60950-1:2005, Second Edition, The International Electrotechnical Commission (IEC).
Information Technology Equipment - Safety - Part 1 : General Requirements.
(Including report of IEC60825-1:2001 clause 8 and clause 9)

Notes

1. Laser (LED Backlight) Information

Class 1M LED Product
IEC60825-1 : 2001
Embedded LED Power (Class1M)
Power : 4.44 mW (Max.)
Wavelength : 258 ~ 622 (nm)
Width : 1.5 x 0.6 (mm)

2. Caution

- : LED inside.
- Class 1M laser (LEDs) radiation when open.
- Do not open while operating.

7-2. EMC

- a) ANSI C63.4 "American National Standard for Methods of Measurement of Radio-Noise Emissions from Low-Voltage Electrical and Electronic Equipment in the Range of 9 kHz to 40 GHz." American National Standards Institute (ANSI), 2003.
- b) CISPR 22 "Information technology equipment – Radio disturbance characteristics – Limit and methods of measurement." International Special Committee on Radio Interference (CISPR), 2005.
- c) CISPR 13 "Sound and television broadcast receivers and associated equipment – Radio disturbance characteristics – Limits and method of measurement." International Special Committee on Radio Interference (CISPR), 2006.

7-3. Environment

- a) RoHS, Directive 2002/95/EC of the European Parliament and of the council of 27 January 2003

Product Specification

8. Packing

8-1. Designation of lot mark

a) Lot mark

A	B	C	D	E	F	G	H	I	J	K	L	M
---	---	---	---	---	---	---	---	---	---	---	---	---

A,B,C : Size (Inch)
E : Month

D : Year
F ~ M : Serial No.

Note:

1. Year

Year	2001	2002	2003	2004	2005	2006	2007	2008	2009	2010
Mark	1	2	3	4	5	6	7	8	9	0

2. Month

Month	Jan	Feb	Mar	Apr	May	Jun	Jul	Aug	Sep	Oct	Nov	Dec
Mark	1	2	3	4	5	6	7	8	9	A	B	C

b) Location of lot mark

Serial No. is printed on the label. The label is attached to the backside of the LCD module.
This is subject to change without prior notice.

8-2. Packing form

a) Package quantity in one box : 8pcs

b) Box size : 543mm X 305mm X 390mm

Product Specification**9. Precautions**

Please pay attention to the followings when you use this TFT LCD module.

9-1. Mounting Precautions

- (1) You must mount a module using holes arranged in four corners or four sides.
- (2) You should consider the mounting structure so that uneven force (ex. Twisted stress) is not applied to the Module. And the case on which a module is mounted should have sufficient strength so that external force is not transmitted directly to the module.
- (3) Please attach the surface transparent protective plate to the surface in order to protect the polarizer. Transparent protective plate should have sufficient strength in order to resist external force.
- (4) You should adopt radiation structure to satisfy the temperature specification.
- (5) Acetic acid type and chlorine type materials for the cover case are not desirable because the former generates corrosive gas of attacking the polarizer at high temperature and the latter causes circuit break by electro-chemical reaction.
- (6) Do not touch, push or rub the exposed polarizers with glass, tweezers or anything harder than HB pencil lead. And please do not rub with dust clothes with chemical treatment. Do not touch the surface of polarizer for bare hand or greasy cloth. (Some cosmetics are detrimental to the polarizer.)
- (7) When the surface becomes dusty, please wipe gently with absorbent cotton or other soft materials like chamois soaks with petroleum benzene. Normal-hexane is recommended for cleaning the adhesives used to attach front / rear polarizers. Do not use acetone, toluene and alcohol because they cause chemical damage to the polarizer.
- (8) Wipe off saliva or water drops as soon as possible. Their long time contact with polarizer causes deformations and color fading.
- (9) Do not open the case because inside circuits do not have sufficient strength.

9-2. Operating precautions

- (1) The spike noise causes the mis-operation of circuits. It should be lower than following voltage : $V = \pm 200\text{mV}$ (Over and under shoot voltage)
- (2) Response time depends on the temperature. (In lower temperature, it becomes longer.)
- (3) Brightness depends on the temperature. (In lower temperature, it becomes higher.) And in lower temperature, response time (required time that brightness is stable after turned on) becomes longer.
- (4) Be careful for condensation at sudden temperature change. Condensation makes damage to polarizer or electrical contacted parts. And after fading condensation, smear or spot will occur.
- (5) When fixed patterns are displayed for a long time, remnant image is likely to occur.
- (6) Module has high frequency circuits. Sufficient suppression to the electromagnetic interference shall be done by system manufacturers. Grounding and shielding methods may be important to minimize the interference.
- (7) Please do not give any mechanical and/or acoustical impact to LCM. Otherwise, LCM can not be operated its full characteristics perfectly.
- (8) A screw which is fastened up the steels should be a machine screw (if not, it causes metal foreign material and deal LCM a fatal blow)
- (9) Please do not set LCD on its edge.

Product Specification**9-3. Electrostatic discharge control**

Since a module is composed of electronic circuits, it is not strong to electrostatic discharge. Make certain that treatment persons are connected to ground through wrist band etc. And don't touch interface pin directly.

9-4. Precautions for strong light exposure

Strong light exposure causes degradation of polarizer and color filter.

9-5. Storage

When storing modules as spares for a long time, the following precautions are necessary.

- (1) Store them in a dark place. Do not expose the module to sunlight or fluorescent light. Keep the temperature between 5°C and 35°C at normal humidity.
- (2) The polarizer surface should not come in contact with any other object.
It is recommended that they be stored in the container in which they were shipped.

9-6. Handling precautions for protection film

- (1) The protection film is attached to the bezel with a small masking tape.
When the protection film is peeled off, static electricity is generated between the film and polarizer. This should be peeled off slowly and carefully by people who are electrically grounded and with well ion-blown equipment or in such a condition, etc.
- (2) When the module with protection film attached is stored for a long time, sometimes there remains a very small amount of glue still on the bezel after the protection film is peeled off.
- (3) You can remove the glue easily. When the glue remains on the bezel surface or its vestige is recognized, please wipe them off with absorbent cotton waste or other soft material like chamois soaked with normal-hexane.