

Product Specification

SPECIFICATION FOR APPROVAL

- () Preliminary Specification
- (●) Final Specification

Title	21.5" Full HD TFT LCD
--------------	------------------------------





BUYER	AOC
MODEL	

SUPPLIER	LG Display Co., Ltd.
*MODEL	LM215WF1
SUFFIX	TLF1

*When you obtain standard approval,
please use the above model name without suffix

APPROVED BY	SIGNATURE DATE
/	
/	
/	

Please return 1 copy for your confirmation with your signature and comments.

APPROVED BY	SIGNATURE DATE
S. G. HONG / G.Manager	 2010.08.09
REVIEWED BY	
K. H. CHOI / Manager [C]	 2010.08.09
Y. H. HWANG / Manager[M]	
M. S. KANG / Manager [P]	
PREPARED BY	
S. Y. KIM / Engineer	 2010.08.09

MNT Products Engineering Dept.
LG Display Co., Ltd

Product Specification
Contents

No	ITEM	Page
	COVER	1
	CONTENTS	2
	RECORD OF REVISIONS	3
1	GENERAL DESCRIPTION	4
2	ABSOLUTE MAXIMUM RATINGS	5
3	ELECTRICAL SPECIFICATIONS	6
3-1	ELECTRICAL CHARACTREISTICS	6
3-2	INTERFACE CONNECTIONS	9
3-3	SIGNAL TIMING SPECIFICATIONS	13
3-4	SIGNAL TIMING WAVEFORMS	14
3-5	COLOR INPUT DATA REFERNECE	15
3-6	POWER SEQUENCE	16
3-7	V _{LCD} POWER DIP CONDITION	17
4	OPTICAL SFECIFICATIONS	18
5	MECHANICAL CHARACTERISTICS	24
6	RELIABLITY	25
7	INTERNATIONAL STANDARDS	28
7-1	SAFETY	28
7-2	EMC	28
7-3	Environment	28
8	PACKING	29
8-1	DESIGNATION OF LOT MARK	29
8-2	PACKING FORM	29
9	PRECAUTIONS	30

Product Specification**RECORD OF REVISIONS**

Revision No	Revision Date	Page	Description
0.1	May. 18. 2010	-	First Draft(Preliminary)
1.0	Aug. 09. 2010	-	Final CAS
		26	The 2D drawing (rear view) update.
1.1	Aug. 16. 2010	6	Permissive Power Input Ripple update (customer request, 100→300)
		6	Rush current update (customer request, 3→3.16)

Product Specification

1. General Description

LM215WF1 is a Color Active Matrix Liquid Crystal Display with an integral Cold Cathode Fluorescent Lamp(CCFL) backlight system. The matrix employs a-Si Thin Film Transistor as the active element. It is a transmissive type display operating in the normally white mode. It has a 21.5inch diagonally measured active display area with Full HD resolution (1080 vertical by 1920 horizontal pixel array). Each pixel is divided into Red, Green and Blue sub-pixels or dots which are arranged in vertical stripes. Gray scale or the brightness of the sub-pixel color is determined with a 8-bit gray scale signal for each dot, thus, presenting a palette of more than 16,7M(True) colors.

It has been designed to apply the 8Bit 2 port LVDS interface.

It is intended to support displays where high brightness, super wide viewing angle, high color saturation, and high color are important.

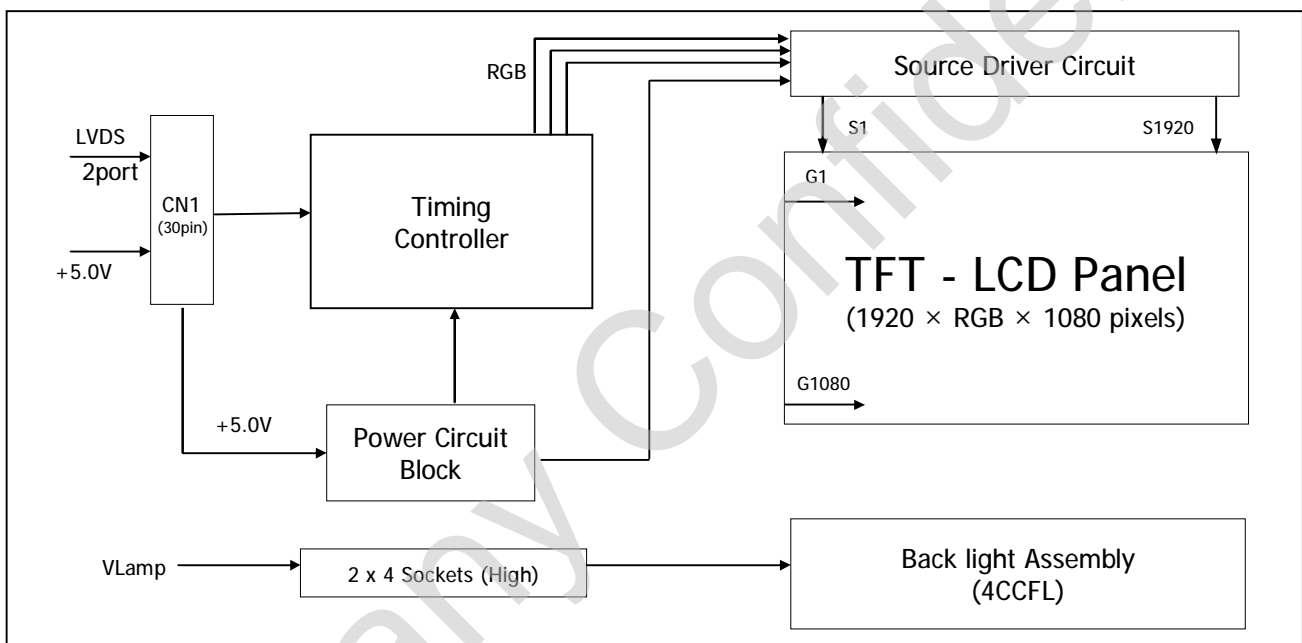

General Features [Figure 1] Block diagram

Active Screen Size	21.53 inches(546.86mm) diagonal
Outline Dimension	495.6(H) x 292.2(V) x 16.5(D) mm (Typ.)
Pixel Pitch	0.248 mm x 0.248mm
Pixel Format	1920 horiz. By 1080 vert. Pixels RGB stripes arrangement
Color Depth	8-bit (6bit + A FRC)
Luminance, White	300 cd/m ² (Center 1 points)
Viewing Angle(CR>10)	View Angle Free (R/L 170(Typ.), U/D 160(Typ.))
Power Consumption	Total 28.97W(typ)/logic4.97W, Inverter 24W @ lamp current 7.5mA
Weight	2100g (typ.)
Display Operating Mode	Transmissive mode, normally white
Surface Treatment	Hard coating(3H), Anti-glare treatment of the front polarizer

Product Specification

2. Absolute Maximum Ratings

The following are maximum values which, if exceeded, may cause faulty operation or damage to the unit.

Table 1. ABSOLUTE MAXIMUM RATINGS

Parameter	Symbol	Values		Units	Notes
		Min	Max		
Power Input Voltage	V _{LCD}	0	+6.0	V _{dc}	at 25 ± 2°C
Operating Temperature	T _{OP}	0	50	°C	1, 2
Storage Temperature	T _{ST}	-20	60	°C	
Operating Ambient Humidity	H _{OP}	10	90	%RH	
Storage Humidity	H _{ST}	10	90	%RH	

Note : 1. Temperature and relative humidity range are shown in the figure below.

Wet bulb temperature should be 39 °C Max, and no condensation of water.

Note : 2. Maximum Storage Humidity is up to 40°C, 70% RH only for 4 corner light leakage Mura.

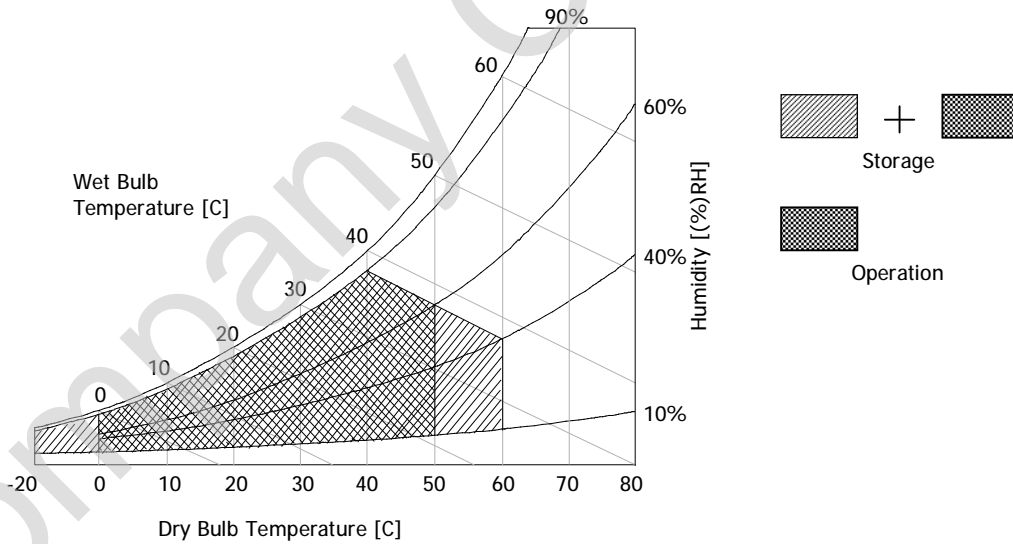

[Figure 2] Temperature and relative humidity

Product Specification

3. Electrical Specifications

3-1. Electrical Characteristics

It requires two power inputs. One is employed to power the LCD electronics and to drive the TFT array and liquid crystal. The second input power for the CCFL, is typically generated by an inverter. The inverter is an external unit to the LCDs.

Table 2. ELECTRICAL CHARACTERISTICS

Parameter	Symbol	Values			Unit	Notes
		Min	Typ	Max		
MODULE :						
Power Supply Input Voltage	V _{LCD}	4.5	5.0	5.5	V _{dc}	
Permissive Power Input Ripple	V _{RF}	-	-	300	mV	13
Power Supply Input Current	I _{LCD}	695	993	1291	mA	1
		900	1285	1671	mA	2
Power Consumption	PLCD		4.97	6.46	Watt	1
	PLCD		6.43	8.36	Watt	2
Rush current	I _{RUSH}	-	-	3.16	A	3
LAMP :						
Operating Voltage	V _{BL}	(780) (8.0mA)	(800) (7.5mA)	(1000) (2.5mA)	V _{RMS}	4, 5
Operating Current	I _{BL}	2.5	7.5	8.0	mA _{RMS}	4
Established Starting Voltage	V _S					4, 6
	at 25 °C			1250	V _{RMS}	
	at 0 °C			1550	V _{RMS}	
Operating Frequency	f _{BL}	40	-	70	kHz	7
Discharge Stabilization Time	T _S			3.0	Min	4, 8
Power Consumption	P _{BL}	-	(24)	(26.4)	Watt	9
Life Time		50,000			Hrs	4, 10

Note : The design of the inverter must have specifications for the lamp in LCD Assembly.

The performance of the Lamp in LCM, for example life time or brightness, is extremely influenced by the characteristics of the DC-AC inverter. So all the parameters of an inverter should be carefully designed so as not to produce too much leakage current from high-voltage output of the inverter.

When you design or order the inverter, please make sure unwanted lighting caused by the mismatch of the lamp and the inverter (no lighting, flicker, etc) never occurs. When you confirm it, the LCD-Assembly should be operated in the same condition as installed in you instrument.

Product Specification

Note. Do not attach a conducting tape to lamp connecting wire. If the lamp wire attach to a conducting tape, TFT-LCD Module has a low luminance and the inverter has abnormal action. Because leakage current is occurred between lamp wire and conducting tape.

1. The specified current and power consumption are under the $V_{LCD}=5.0V$, $25 \pm 2^{\circ}C$, $f_V=60Hz$ condition whereas mosaic pattern(8 x 6) is displayed and f_V is the frame frequency.
2. The current is specified at the full black pattern..
3. The duration of rush current is about 5ms and rising time of power Input is $500\mu s \pm 20\%$. (min.).
4. Specified values are for a single lamp.
5. Operating voltage is measured at $25 \pm 2^{\circ}C$, and follows as below condition.
The variance of the voltage is $\pm 10\%$. (Based on single Lamp.)
The variance of the voltage is $\pm 20\%$. (Based on system & Test equipment tolerance.)
6. The voltage above V_S should be applied to the lamps for more than 1 second for start-up.
(Inverter open voltage must be more than lamp starting voltage.)
Otherwise, the lamps may not be turned on. The used lamp current is the lamp typical current.
7. The output of the inverter must have symmetrical(negative and positive) voltage waveform and symmetrical current waveform (Unsymmetrical ratio is less than 10%). Please do not use the inverter which has unsymmetrical voltage and unsymmetrical current and spike wave.
Lamp frequency may produce interface with horizontal synchronous frequency and as a result this may cause beat on the display. Therefore lamp frequency shall be as away possible from the horizontal synchronous frequency and from its harmonics in order to prevent interference.
8. Let's define the brightness of the lamp after being lighted for 5 minutes as 100%.
 T_S is the time required for the brightness of the center of the lamp to be not less than 95%.
The used lamp current is the lamp typical current.
9. The lamp power consumption shown above does not include loss of external inverter.
The used lamp current is the lamp typical current. ($P_{BL} = V_{BL} \times I_{BL} \times N_{Lamp}$)
10. The life is determined as the time at which brightness of the lamp is 50% compared to that of initial value at the typical lamp current on condition of continuous operating at $25 \pm 2^{\circ}C$.
11. Requirements for a system inverter design, which is intended to have a better display performance, a better power efficiency and a more reliable lamp, are following.
It shall help increase the lamp lifetime and reduce leakage current.
 - a. The asymmetry rate of the inverter waveform should be less than 10%.
 - b. The distortion rate of the waveform should be within $\sqrt{2} \pm 10\%$.
 * Inverter output waveform had better be more similar to ideal sine wave.

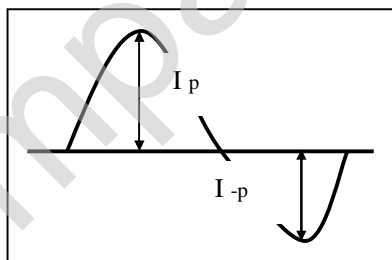

* Asymmetry rate:

$$| I_p - I_{-p} | / I_{rms} \times 100\%$$

* Distortion rate

$$I_p \text{ (or } I_{-p}) / I_{rms}$$

12. The inverter which is combined with this LCM, is highly recommended to connect coupling(ballast) condenser at the high voltage output side. When you use the inverter which has not coupling(ballast) condenser, it may cause abnormal lamp lighting because of biased mercury as time goes.
13. Permissive power ripple should be measured under $V_{LCD} = 5.0V$, $25^{\circ}C$, f_V (frame frequency)=MAX condition and At that time, we recommend the bandwidth configuration of oscilloscope is to be under 20Mhz. See the figure 3.
14. In case of edgy type back light with over 4 parallel lamps, input current and voltage wave form should be synchronized

Product Specification

- Permissive Power input ripple ($V_{LCD} = 5.0V$, $25^{\circ}C$, $fV(\text{frame frequency}) = \text{MAX}$ condition)

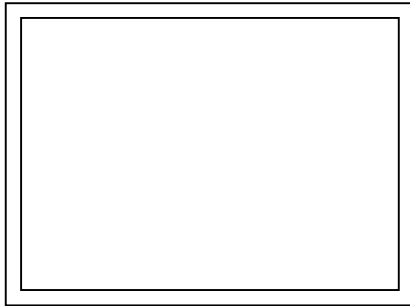

White pattern

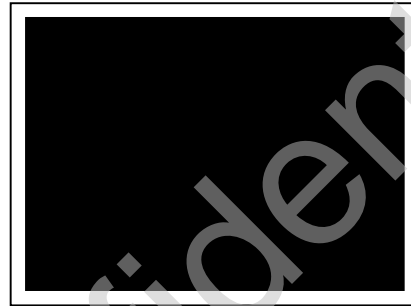

Black pattern

- Power consumption ($V_{LCD} = 5.0V$, $25^{\circ}C$, fV (frame frequency) = 60Hz condition)

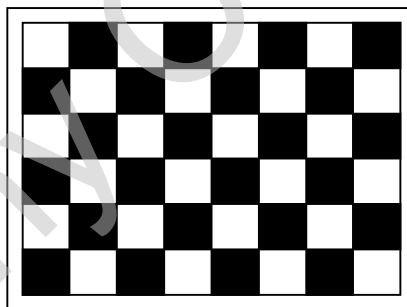

Mosaic Pattern

[Figure 3] Mosaic pattern & Black Pattern for power consumption measurement

Product Specification

3-2. Interface Connections

3-2-1. LCD Module

- LCD Connector(CN1). :IS100-L30B-C23 (UJU) or Equivalent
- Mating Connector : FI-XC30C2L (Manufactured by JAE) or Equivalent

Table 3 MODULE CONNECTOR(CN1) PIN CONFIGURATION

No	Symbol	Description	No	Symbol	Description
1	FR0M	- Signal of odd channel 0 (LVDS)	16	SR1P	+ Signal of even channel 1 (LVDS)
2	FR0P	+ Signal of odd channel 0 (LVDS)	17	GND	Ground
3	FR1M	- Signal of odd channel 1 (LVDS)	18	SR2M	- Signal of even channel 2 (LVDS)
4	FR1P	+ Signal of odd channel 1 (LVDS)	19	SR2P	+ Signal of even channel 2 (LVDS)
5	FR2M	- Signal of odd channel 2 (LVDS)	20	SCLKINM	- Signal of even clock channel (LVDS)
6	FR2P	+ Signal of odd channel 2 (LVDS)	21	SCLKINP	+ Signal of even clock channel (LVDS)
7	GND	Ground	22	SR3M	- Signal of even channel 3 (LVDS)
8	FCLKINM	- Signal of odd clock channel (LVDS)	23	SR3P	+ Signal of even channel 3 (LVDS)
9	FCLKINP	+ Signal of odd clock channel (LVDS)	24	GND	Ground
10	FR3M	- Signal of odd channel 3 (LVDS)	25	NC	NC (reserved I2C communication)
11	FR3P	+ Signal of odd channel 3 (LVDS)	26	NC	NC (reserved I2C communication)
12	SR0M	- Signal of even channel 0 (LVDS)	27	PWM	PWM_OUT for control burst frequency of Inverter
13	SR0P	+ Signal of even channel 0 (LVDS)	28	VLCD	Power +5V
14	GND	Ground	29	VLCD	Power +5V
15	SR1M	- Signal of even channel 1 (LVDS)	30	VLCD	Power +5V

- Note:
1. All GND(ground) pins should be connected together and to Vss which should also be connected to the LCD's metal frame.
 2. All VLCD (power input) pins should be connected together.
 3. Input Level of LVDS signal is based on the IEA 664 Standard.

[Figure 4] User Connector diagram



Product Specification

LVDS Input characteristics

1. DC Specification

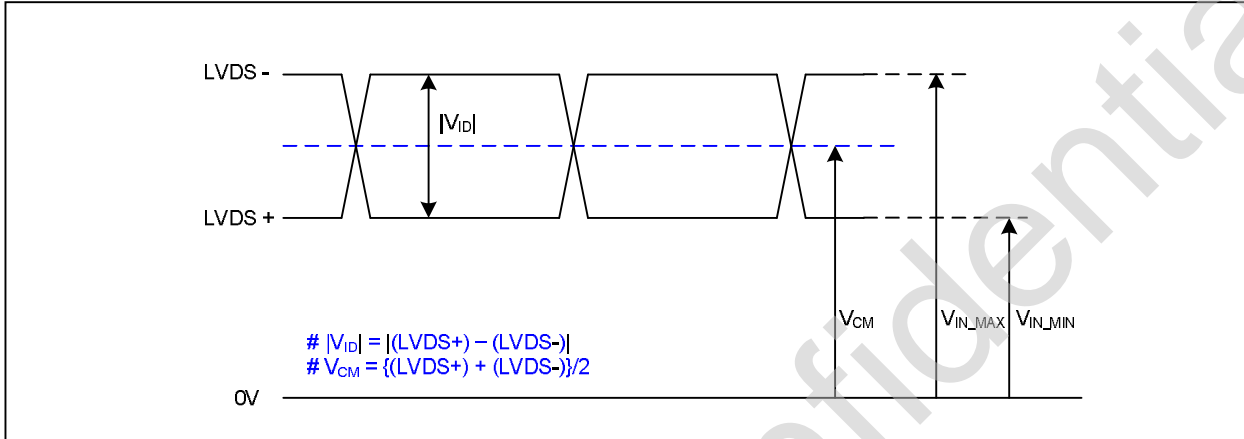

Description	Symbol	Min	Max	Unit	Notes
LVDS Differential Voltage	$ V_{ID} $	200	600	mV	-
LVDS Common mode Voltage	V_{CM}	0.6	1.8	V	-
LVDS Input Voltage Range	V_{IN}	0.3	2.1	V	-

2. AC Specification

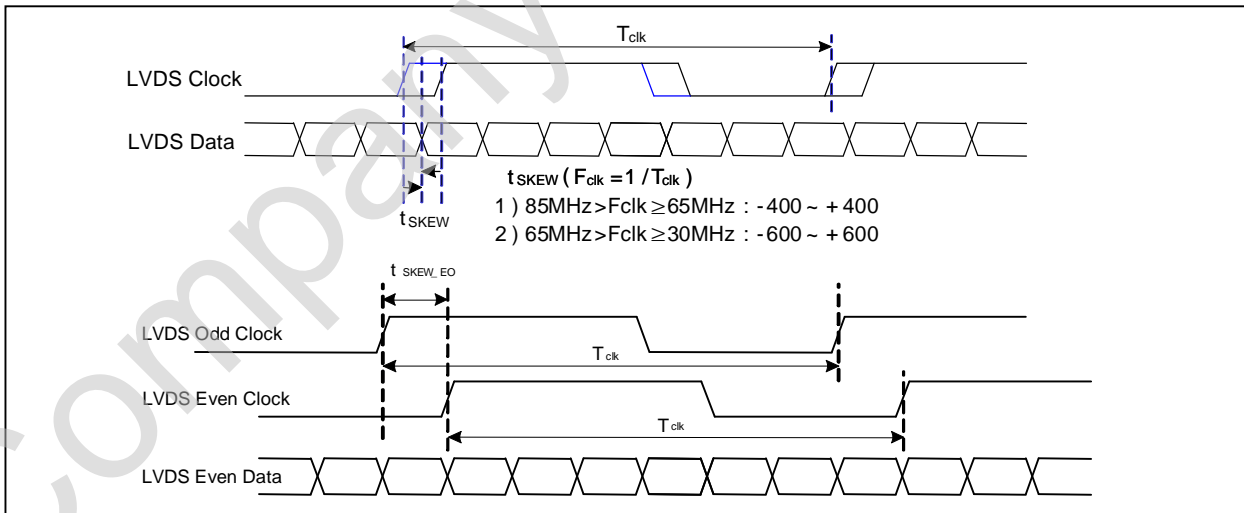

Description	Symbol	Min	Max	Unit	Notes
LVDS Clock to Data Skew Margin	t_{SKEW}	- 400	+ 400	ps	85MHz > Fclk ≥ 65MHz
	t_{SKEW}	- 600	+ 600	ps	65MHz > Fclk ≥ 30MHz
LVDS Clock to Clock Skew Margin (Even to Odd)	t_{SKEW_EO}	- 1/7	+ 1/7	T_{clk}	-

Product Specification

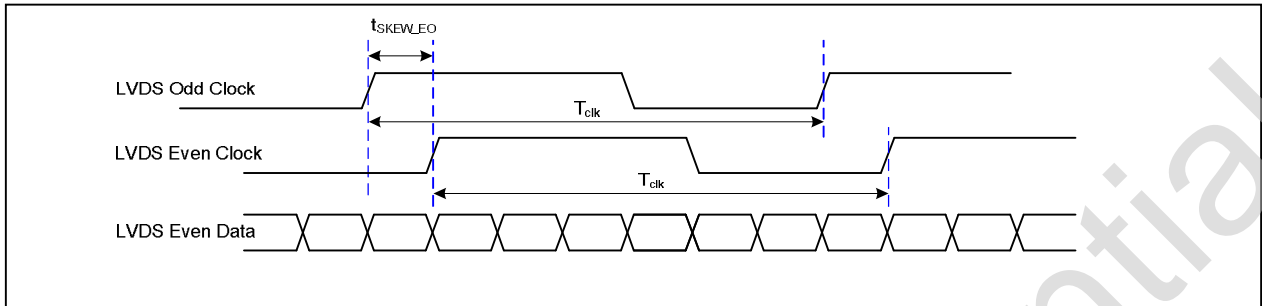

< Clock skew margin between channel >

3. Data Format

1) LVDS 2 Port

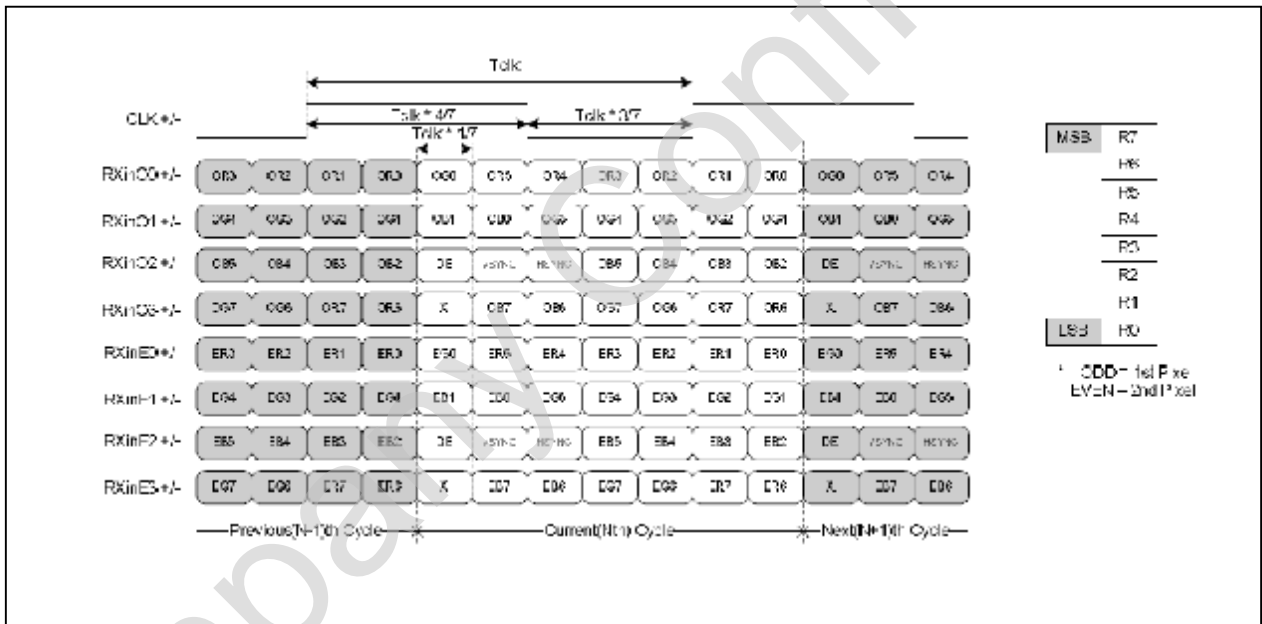

< LVDS Data Format >

Product Specification

Table 4. BACKLIGHT CONNECTOR PIN CONFIGURATION(CN2,CN3,CN4,CN5)

The backlight interface connector is a model 35001HS-02LD manufactured by Yeonho. The mating connector part number are 35001WR-02L or equivalent. The pin configuration for the connector is shown in the table below.

Pin	Symbol	Description	NOTES
1	HV	High Voltage for Lamp	1
2	LV	Low Voltage for Lamp	1, 2

- Note :
1. The high voltage power terminal is colored pink, white
The low voltage pin color is sky blue, white.
 2. The backlight ground should be common with LCD metal frame.
 3. 35001HS-02LD (Locking type)

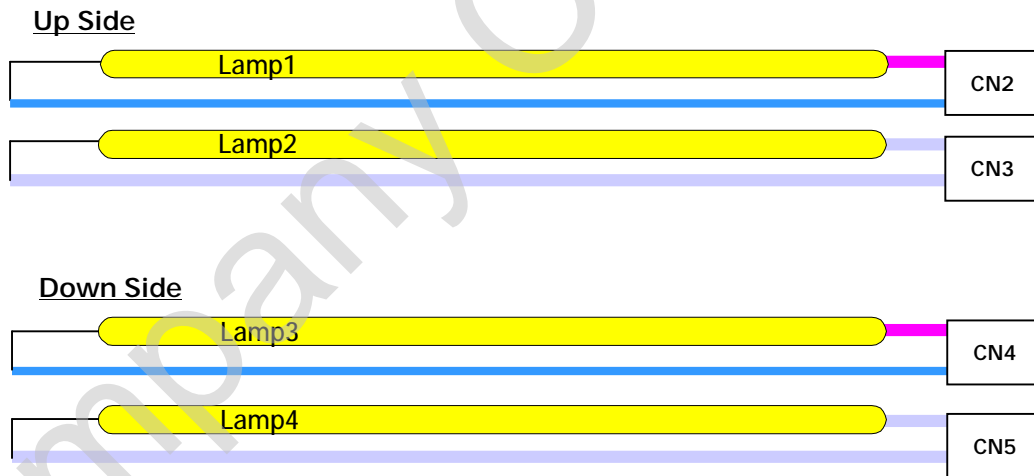

[Figure 5] Backlight connector diagram

Product Specification
3-3. Signal Timing Specifications

This is the signal timing required at the input of the User connector. All of the interface signal timing should be satisfied with the following specifications for it's proper operation.

Table 5. Timing Table

ITEM	Symbol		Min	Typ	Max	Unit	Note
DCLK	Period	t _{CLK}	11.43	13.89	16.67	ns	Pixel frequency : Typ.144MHz
	Frequency	-	60	72	87.5	MHz	
Horizontal	total	t _{HP}	1000	1088	1120	t _{CLK}	
	Frequency	f _H	64	66	83	KHz	
	Blanking		40	128	160	t _{CLK}	
	valid	t _{WH}	960	960	960	t _{CLK} /2	
Vertical	total	t _{VP}	1090	1100	1160	t _{HP}	
	Frequency	f _V	50	60	75	Hz	
	Blanking		10	20	80	t _{HP}	
	valid	t _{WV}	1080	1080	1080	t _{HP}	

Note:

1. DE Only mode operation. The input of Hsync & Vsync signal does not have an effect on LCD normal operation.
2. The performance of the electro-optical characteristics may be influenced by variance of the vertical refresh rates.
3. Horizontal period should be even.

Product Specification

3-4. Signal Timing Waveforms

1. Dclk, DE, DATA waveforms

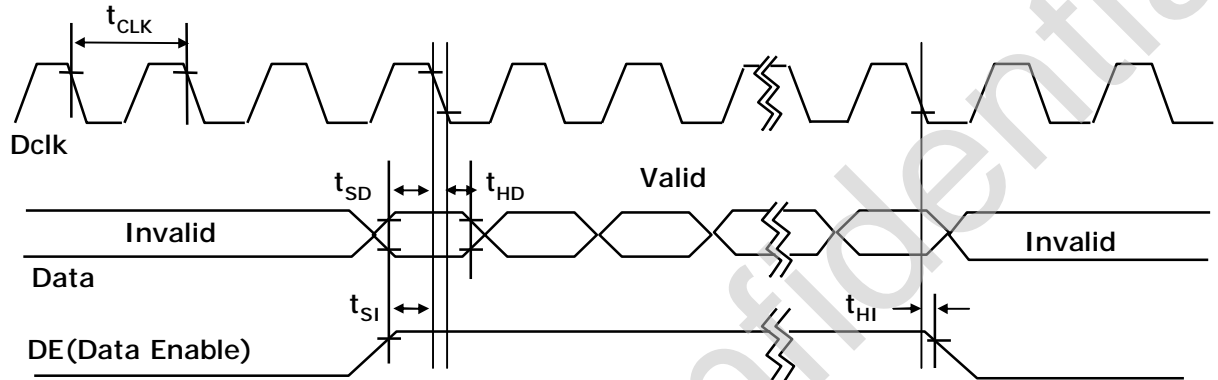

2. Horizontal waveform

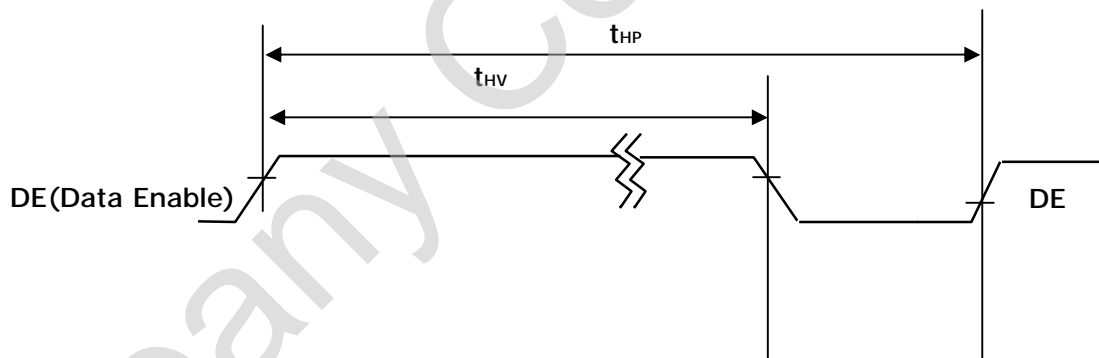

3. Vertical waveform

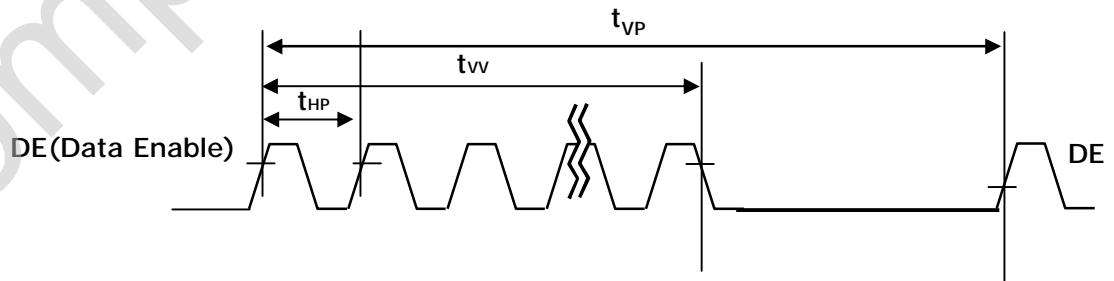

Product Specification
3-5. Color Input Data Reference

The Brightness of each primary color(red,green,blue) is based on the 8-bit gray scale data input for the color; the higher the binary input, the brighter the color. The table below provides a reference for color versus data input.

Table 6. COLOR DATA REFERENCE

Color		Input Color Data																							
		RED								GREEN								BLUE							
		MSB				LSB				MSB				LSB				MSB				LSB			
		R7	R6	R5	R4	R3	R2	R1	R0	G7	G6	G5	G4	G3	G2	G1	G0	B7	B6	B5	B4	B3	B2	B1	B0
Basic Color	Black	0	0	0	0	0	0	0	0	0	0	0	0	0	0	0	0	0	0	0	0	0	0	0	0
	Red (255)	1	1	1	1	1	1	1	1	0	0	0	0	0	0	0	0	0	0	0	0	0	0	0	0
	Green (255)	0	0	0	0	0	0	0	0	1	1	1	1	1	1	1	1	0	0	0	0	0	0	0	0
	Blue (255)	0	0	0	0	0	0	0	0	0	0	0	0	0	0	0	0	1	1	1	1	1	1	1	1
	Cyan	0	0	0	0	0	0	0	0	1	1	1	1	1	1	1	1	1	1	1	1	1	1	1	1
	Magenta	1	1	1	1	1	1	1	1	0	0	0	0	0	0	0	0	1	1	1	1	1	1	1	1
	Yellow	1	1	1	1	1	1	1	1	1	1	1	1	1	1	1	1	0	0	0	0	0	0	0	0
	White	1	1	1	1	1	1	1	1	1	1	1	1	1	1	1	1	1	1	1	1	1	1	1	1
RED	RED (000) Dark	0	0	0	0	0	0	0	0	0	0	0	0	0	0	0	0	0	0	0	0	0	0	0	0
	RED (001)	0	0	0	0	0	0	0	1	0	0	0	0	0	0	0	0	0	0	0	0	0	0	0	0
							
	RED (254)	1	1	1	1	1	1	1	0	0	0	0	0	0	0	0	0	0	0	0	0	0	0	0	0
	RED (255)	1	1	1	1	1	1	1	1	0	0	0	0	0	0	0	0	0	0	0	0	0	0	0	0
GREEN	GREEN (000) Dark	0	0	0	0	0	0	0	0	0	0	0	0	0	0	0	0	0	0	0	0	0	0	0	0
	GREEN (001)	0	0	0	0	0	0	0	0	0	0	0	0	0	0	0	1	0	0	0	0	0	0	0	0
							
	GREEN (254)	0	0	0	0	0	0	0	0	1	1	1	1	1	1	1	0	0	0	0	0	0	0	0	0
	GREEN (255)	0	0	0	0	0	0	0	0	1	1	1	1	1	1	1	1	0	0	0	0	0	0	0	0
BLUE	BLUE (000) Dark	0	0	0	0	0	0	0	0	0	0	0	0	0	0	0	0	0	0	0	0	0	0	0	0
	BLUE (001)	0	0	0	0	0	0	0	0	0	0	0	0	0	0	0	0	0	0	0	0	0	0	0	1
							
	BLUE (254)	0	0	0	0	0	0	0	0	0	0	0	0	0	0	0	0	1	1	1	1	1	1	1	0
	BLUE (255)	0	0	0	0	0	0	0	0	0	0	0	0	0	0	0	0	1	1	1	1	1	1	1	1

Product Specification

3-6. Power Sequence

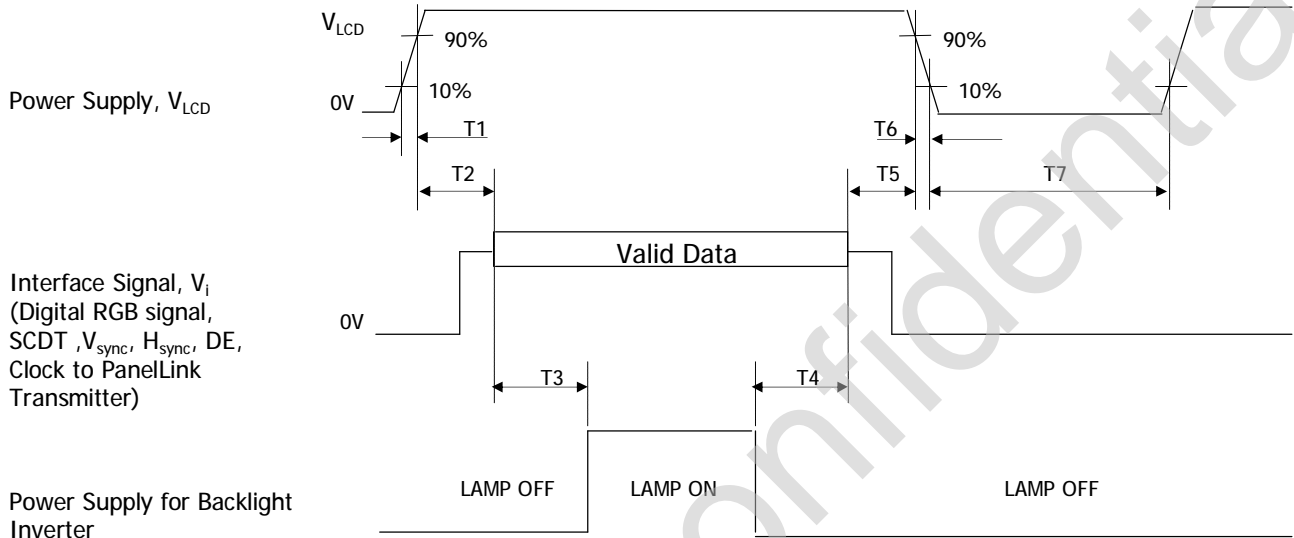

[Figure 6] Power sequence

Table 7. POWER SEQUENCE

Parameter	Values			Units
	Min	Typ	Max	
T1	0.5	-	10	ms
T2	0.01	-	50	ms
T3	500	-	-	ms
T4	200	-	-	ms
T5	0.01	-	50	ms
T6	-	-	-	ms
T7	1	-	-	s

- Notes :
1. Please avoid floating state of interface signal at invalid period.
 2. When the interface signal is invalid, be sure to pull down the power supply for LCD V_{LCD} to 0V.
 3. Lamp power must be turn on after power supply for LCD and interface signal are valid.

Product Specification

3-7. V_{LCD} Power Dip Condition

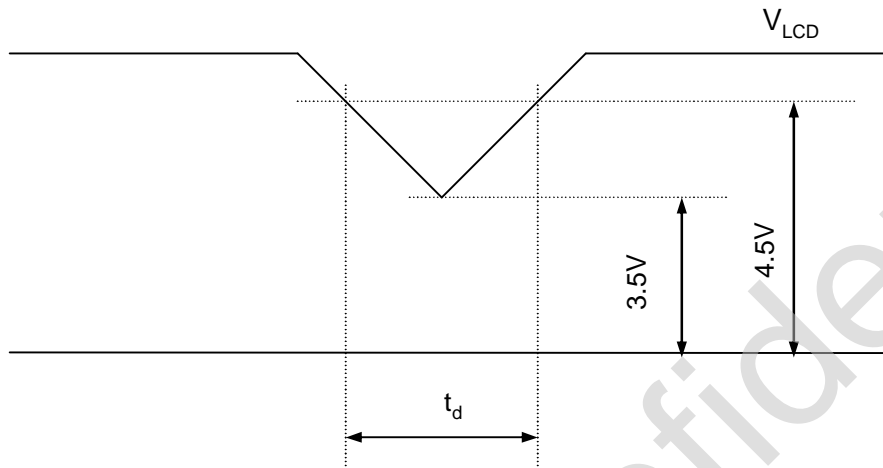

[Figure 7] Power dip condition

1) Dip condition

$$3.5V \leq V_{LCD} < 4.5V, t_d \leq 20ms$$

2) $V_{LCD} < 3.5V$

V_{LCD} -dip conditions should also follow the Power On/Off conditions for supply voltage.

Product Specification

4. Optical Specifications

Optical characteristics are determined after the unit has been 'ON' for approximately 30 minutes in a dark environment at $25 \pm 2^\circ\text{C}$. The values specified are at an approximate distance 50cm from the LCD surface at a viewing angle of Φ and θ equal to 0° and aperture 1 degree.

FIG. 8 presents additional information concerning the measurement equipment and method.

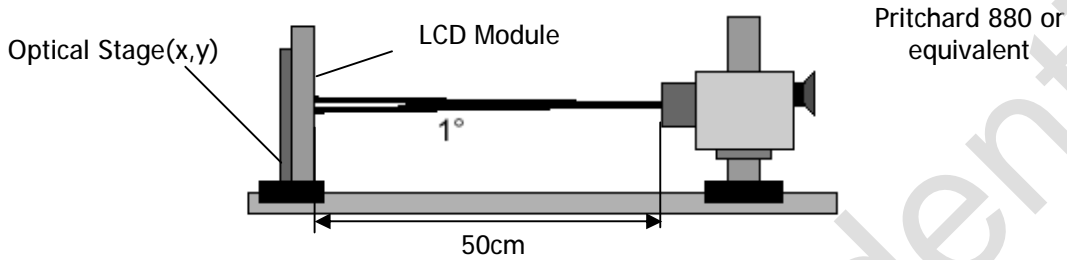

[Figure 8] Optical characteristic measurement equipment and method

Table 8. OPTICAL CHARACTERISTICS (Ta=25 °C, V_{LCD}=5.0V, f_V=60Hz Dclk=144MHz, I_{BL}=7.5mA)

Parameter	Symbol	Values			Units	Notes	
		Min	Typ	Max			
Contrast Ratio	CR	700	1000			1 (PR-880)	
Surface Luminance, white	L _{WH}	250	300		cd/m ²	2 (PR-880)	
Luminance Variation	δ _{WHITE}	75			%	3 (PR-880)	
Response Time	Rise Time	Tr _R	-	1.3	2.6	ms	4 (RD80S)
	Decay Time	Tr _D	-	3.7	7.4	ms	
	total	T		5		ms	
Color Coordinates [CIE1931]	RED	Rx	Typ -0.03	0.646	Typ +0.03		5 (PR-650)
		Ry		0.334			
	GREEN	Gx		0.303			
		Gy		0.616			
	BLUE	Bx		0.147			
		By		0.067			
	WHITE	Wx		0.313			
Wy		0.329					
Color Gamut			72%			5 (PR-650)	
Viewing Angle (CR>5)							6 (PR-880)
CR>5	Horizontal	θ _H	150	176	-	Degree	
	Vertical	θ _V	140	170	-		
Viewing Angle (CR>10)							
General (CR>10)	Horizontal	θ _H	140	170	-	Degree	
	Vertical	θ _V	130	160	-		
Luminance uniformity- Angular dependence(TCO'5.0)	LR				1.73	Fig 11 (PR880)	
Gray Scale				2.2		7 (PR880)	

Product Specification

Notes 1. Contrast Ratio(CR) is defined mathematically as :

$$\text{Contrast Ratio} = \frac{\text{Surface Luminance with all white pixels}}{\text{Surface Luminance with all black pixels}}$$

It is measured at center point(Location P1)

2. Surface luminance is the luminance value at center 1 point(1) across the LCD surface 50cm from the surface with all pixels displaying white. For more information see FIG 9.

3. The variation in surface luminance , δ WHITE is defined as :

$$d_{\text{WHITE}} = \frac{\text{Minimum}(L_{P1}, L_{P2}, \dots, L_{P9})}{\text{Maximum}(L_{P1}, L_{P2}, \dots, L_{P9})} \times 100$$

For more information see FIG 9.

4. Response time is the time required for the display to transition from black to white (Rise Time, Tr_R) and from white to black (Decay Time, Tr_D). For additional information see FIG 10.

5. Color gamut is calculated from CIE 1931 space.

6. Viewing angle is the angle at which the contrast ratio is greater than 5 or 10. The angles are determined for the horizontal or x axis and the vertical or y axis with respect to the z axis which is normal to the LCD surface. For more information see FIG 12.

7. Gray scale specification

Gamma Value is approximately 2.2. For more information see Table 10.

Product Specification

Measuring point for surface luminance & measuring point for luminance variation.

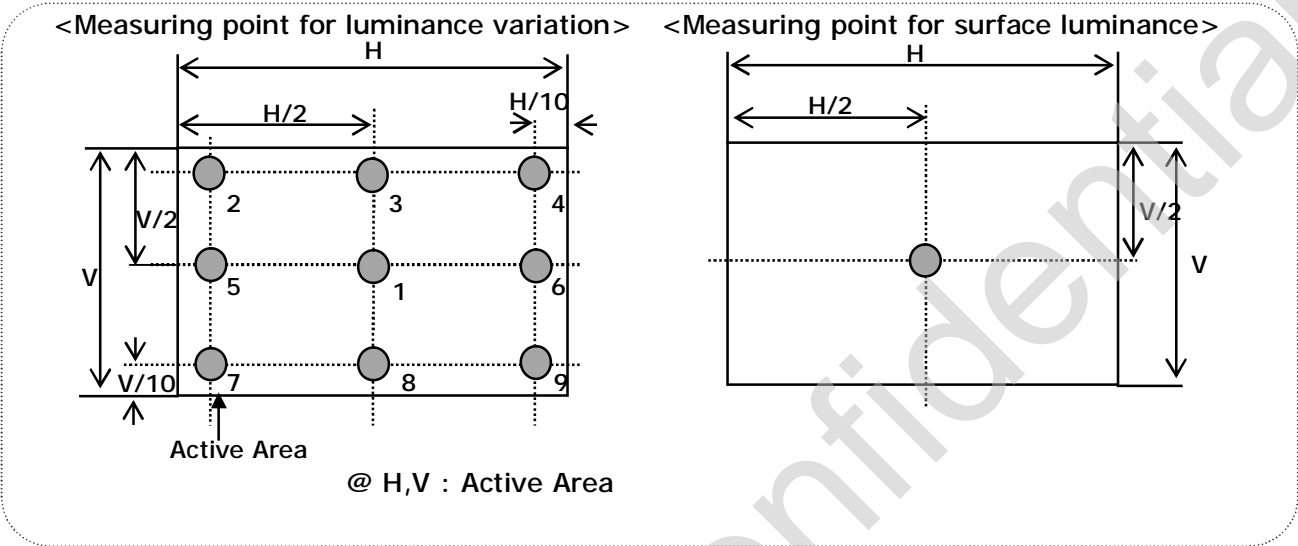

[FIG 9] Measure Point for Luminance

The response time is defined as the following figure and shall be measured by switching the input signal for "black" and "white".

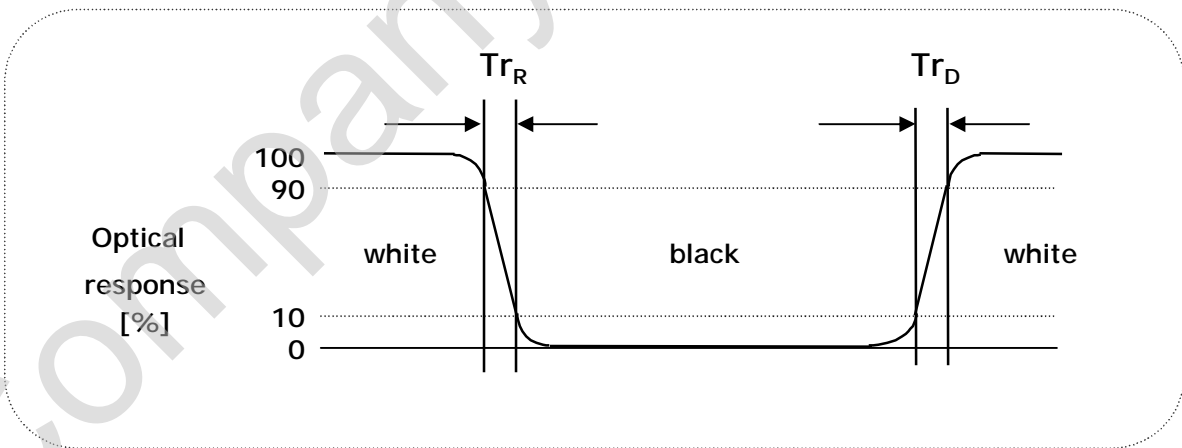

[FIG 10] Response Time

Product Specification

Notes :

Luminance Uniformity - angular - dependence (LR& TB)

TCO 5.0 Luminance uniformity - angular dependence, is the capacity of the FPD to maintain a certain luminance level independently of the viewing direction, The angular-dependent luminance uniformity is defined as the ratio of maximum luminance to minimum luminance in the specified measurement areas.

- Test pattern : Full white 4 ° × 4 ° square size, back ground shall be set to 80% image loading, RGB 204, 204, 204
- Test luminance : $\geq 150\text{cd/m}^2$
- Test point : 5-point
- Test distance : $D * 1.5 = 82\text{cm}$
- Test method : $L_R = ((L_{\text{max.}+30\text{deg.}} / L_{\text{min.}+30\text{deg.}}) + (L_{\text{max.}-30\text{deg.}} / L_{\text{min.}-30\text{deg.}})) / 2$
 $T_B = ((L_{\text{max.}+15\text{deg.}} / L_{\text{min.}+15\text{deg.}})$

FIG. 11 Luminance Uniformity angular dependence

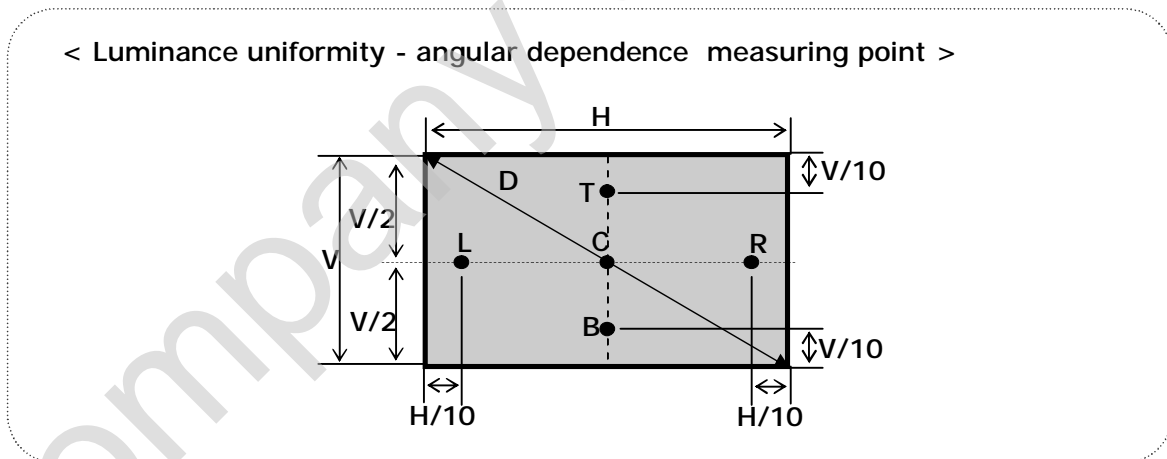

Product Specification

Dimension of viewing angle range.

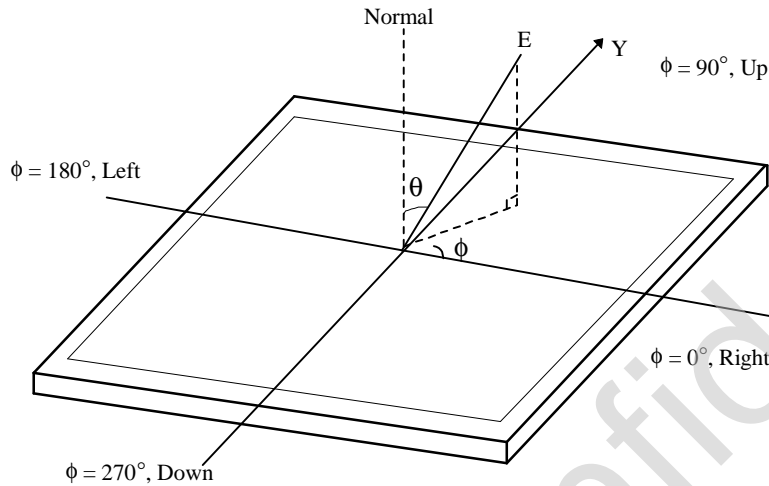

[FIG 12] Viewing angle

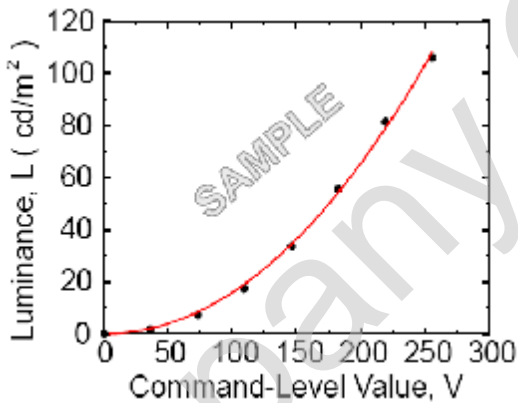

[FIG 13] Sample Luminance vs. gray scale (using a 256 bit gray scale)

$$L = aV^r + L_b$$

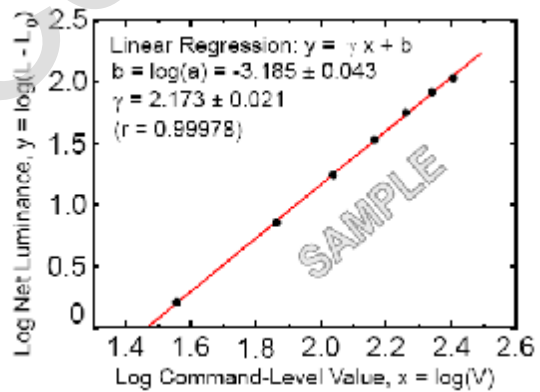

[FIG 14] Sample Log-log plot of luminance vs. gray scale

$$\log(L - L_b) = r \log(V) + \log(a)$$

Here the Parameter α and γ relate the signal level V to the luminance L .
The GAMMA we calculate from the log-log representation (FIG. 14)

Product Specification
Table 10. Gray Scale Specification

Gray Level	Relative Luminance [%] (Typ.)
0	0.11
31	1.08
63	4.72
95	11.49
127	21.66
159	35.45
191	53.00
223	74.48
255	100

Company Confidential

Product Specification
5. Mechanical Characteristics

The contents provide general mechanical characteristics. In addition the figures in the next page are detailed mechanical drawing of the LCD.

Outline Dimension	Horizontal	495.6mm ± 0.5mm
	Vertical	292.2mm ± 0.5mm
	Depth	16.5mm ± 0.5mm
Bezel Area	Horizontal	479.84mm
	Vertical	271.31mm
Active Display Area	Horizontal	476.64mm
	Vertical	268.11mm
Weight	2100g(typ)	
Surface Treatment	Hard coating(3H) Anti-Glare treatment of the front polarizer	

Notes : Please refer to a mechanic drawing in terms of tolerance at the next page.

Product Specification

<FRONT VIEW>

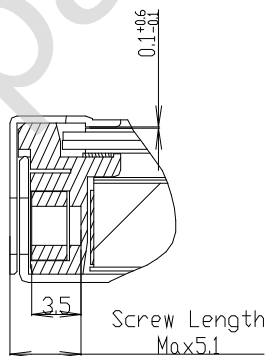
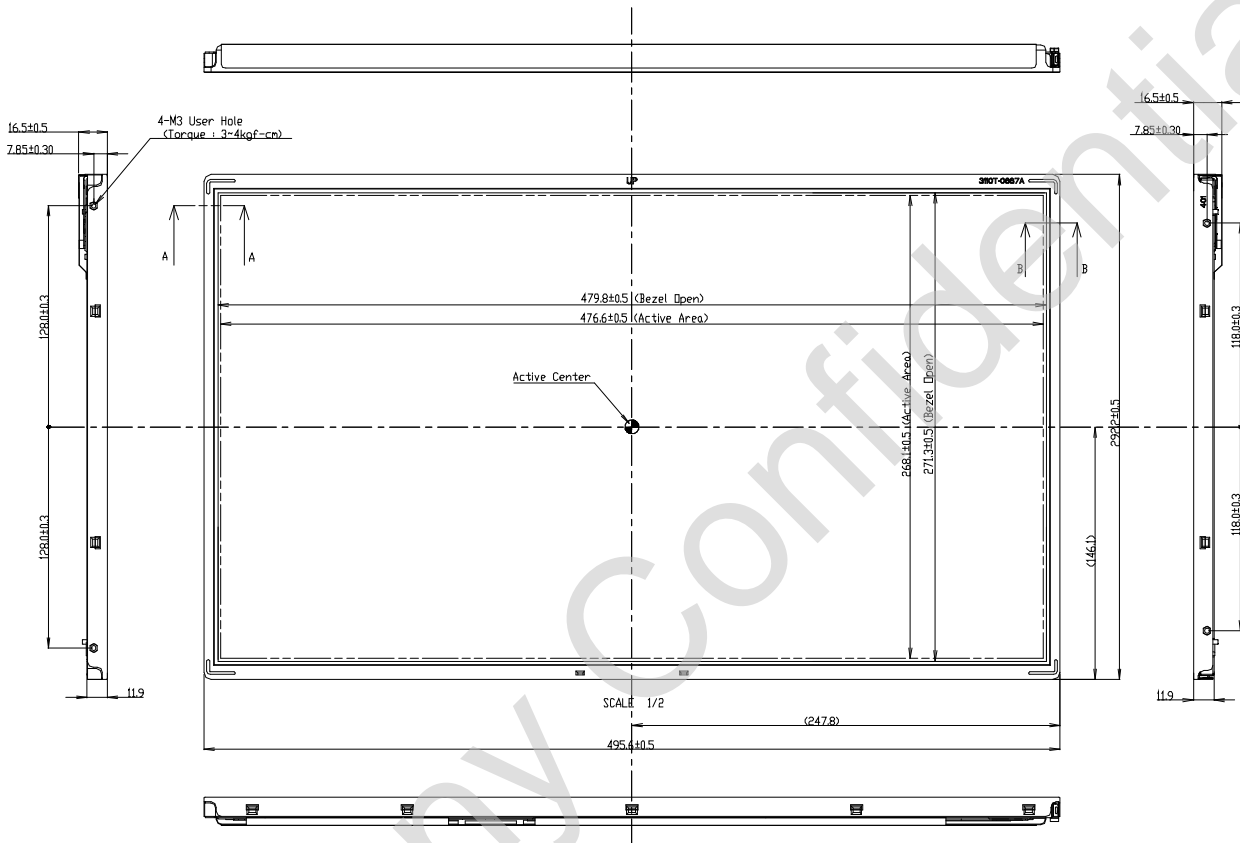

SECTION A-A
SCALE 2/1

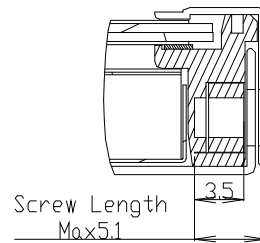

SECTION B-B
SCALE 2/1

Product Specification

<REAR VIEW>

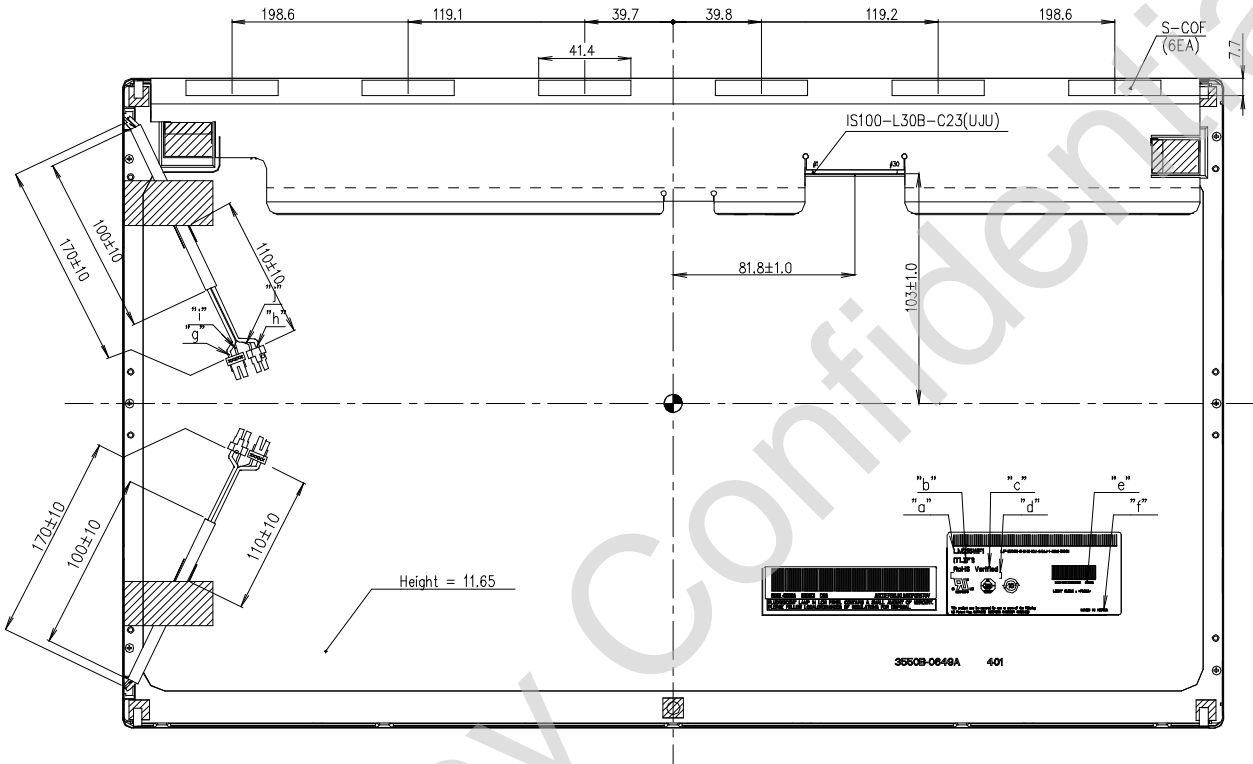

- NOTES
1. Unspecified tolerances to be ± 0.5
 2. Backlight wires and contraction tubes are excluded from outline dimensions.
 3. Torque of user hole : 3.0~4.0 kgf-cm
 4. Lamp Connector Specification : YEONHO 25001HS-02LD <2pin>
 5. I/F Connector Specification : IS100-L30B-C23(UJU) or compatible
 6. Do not wind conductive tape around the backlight wires.
 7. Tilt and partial disposition tolerance of display area as following.
 - (1) Y-Direction : $|A-B| < 1.0$
 - (2) X-Direction : $|C-D| < 1.0$

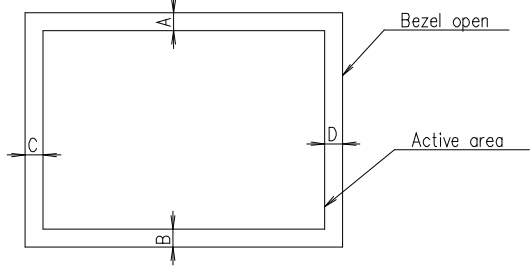

8. The COF area is weak & sensitive so please don't press the COF area

Product Specification
6. Reliability

Environment test condition

No	Test Item	Condition
1	High temperature storage test	Ta= 60°C 240h
2	Low temperature storage test	Ta= -20°C 240h
3	High temperature operation test	Ta= 50°C 50%RH 240h
4	Low temperature operation test	Ta= 0°C 240h
5	Vibration test (non-operating)	Wave form : random Vibration level : 1.0G RMS Bandwidth : 10-300Hz Duration : X,Y,Z, 10 min One time each direction
6	Shock test (non-operating)	Shock level : 100G Waveform : half sine wave, 2ms Direction : ±X, ±Y, ±Z One time each direction
7	Humidity condition Operation	Ta= 40 °C ,90%RH
8	Altitude storage / shipment	0 - 40,000 feet(12192m)

7. International standards

7-1. Safety

- a) UL 60950-1:2003, First Edition, Underwriters Laboratories, Inc.,
Standard for Safety of Information Technology Equipment.
- b) CAN/CSA C22.2, No. 60950-1-03 1st Ed. April 1, 2003, Canadian Standards Association,
Standard for Safety of Information Technology Equipment.
- c) EN 60950-1:2001, First Edition,
European Committee for Electro-technical Standardization(CENELEC)
European Standard for Safety of Information Technology Equipment.
- d) RoHS, Directive 2002/95/EC of the European Parliament and of the council of 27
January 2003

7-2. EMC

- a) ANSI C63.4 "Methods of Measurement of Radio-Noise Emissions from Low-Voltage
Electrical and Electrical Equipment in the Range of 9kHz to 40GHz." American National
Standards Institute(ANSI),1992
- b) C.I.S.P.R "Limits and Methods of Measurement of Radio Interface Characteristics of
Information Technology Equipment." International Special Committee on Radio
Interference.
- c) EN 55022 "Limits and Methods of Measurement of Radio Interface Characteristics of
Information Technology Equipment." European Committee for Electro-technical
Standardization.(CENELEC), 1998 (Including A1: 2000)

7-3. Environment

- a) RoHS, Directive 2002/95/EC of the European Parliament and of the council of 27
January 2003

Product Specification**8. Packing****8-1. Designation of Lot Mark**

a) Lot Mark

A	B	C	D	E	F	G	H	I	J	K	L	M
---	---	---	---	---	---	---	---	---	---	---	---	---

A,B,C : SIZE(INCH)
E : MONTHD : YEAR
F ~ M : SERIAL NO.

Note

1. YEAR

Year	2001	2002	2003	2004	2005	2006	2007	2008	2009	2010
Mark	1	2	3	4	5	6	7	8	9	0

2. MONTH

Month	Jan	Feb	Mar	Apr	May	Jun	Jul	Aug	Sep	Oct	Nov	Dec
Mark	1	2	3	4	5	6	7	8	9	A	B	C

b) Location of Lot Mark

Serial No. is printed on the label. The label is attached to the backside of the LCD module.
This is subject to change without prior notice.

8-2. Packing Form

a) Package quantity in one box : 7pcs

b) Box Size : 370mm x 320mm x 580mm

Product Specification

9. PRECAUTIONS

Please pay attention to the followings when you use this TFT LCD module.

9-1. MOUNTING PRECAUTIONS

- (1) You must mount a module using holes arranged in four corners or four sides.
- (2) You should consider the mounting structure so that uneven force (ex. Twisted stress) is not applied to the module. And the case on which a module is mounted should have sufficient strength so that external force is not transmitted directly to the module.
- (3) Please attach the surface transparent protective plate to the surface in order to protect the polarizer. Transparent protective plate should have sufficient strength in order to resist external force.
- (4) You should adopt radiation structure to satisfy the temperature specification.
- (5) Acetic acid type and chlorine type materials for the cover case are not desirable because the former generates corrosive gas of attacking the polarizer at high temperature and the latter causes circuit break by electro-chemical reaction.
- (6) Do not touch, push or rub the exposed polarizers with glass, tweezers or anything harder than HB pencil lead. And please do not rub with dust clothes with chemical treatment. Do not touch the surface of polarizer for bare hand or greasy cloth. (Some cosmetics are detrimental to the polarizer.)
- (7) When the surface becomes dusty, please wipe gently with absorbent cotton or other soft materials like chamois soaks with petroleum benzene. Normal-hexane is recommended for cleaning the adhesives used to attach front / rear polarizers. Do not use acetone, toluene and alcohol because they cause chemical damage to the polarizer.
- (8) Wipe off saliva or water drops as soon as possible. Their long time contact with polarizer causes deformations and color fading.
- (9) Do not open the case because inside circuits do not have sufficient strength.

9-2. OPERATING PRECAUTIONS

- (1) The spike noise causes the mis-operation of circuits. It should be lower than following voltage :
 $V = \pm 200\text{mV}$ (Over and under shoot voltage)
- (2) Response time depends on the temperature. (In lower temperature, it becomes longer.)
- (3) Brightness depends on the temperature. (In lower temperature, it becomes lower.)
And in lower temperature, response time (required time that brightness is stable after turned on) becomes longer.
- (4) Be careful for condensation at sudden temperature change. Condensation makes damage to polarizer or electrical contacted parts. And after fading condensation, smear or spot will occur.
- (5) When fixed patterns are displayed for a long time, remnant image is likely to occur.
- (6) Module has high frequency circuits. Sufficient suppression to the electromagnetic interference shall be done by system manufacturers. Grounding and shielding methods may be important to minimize the interference.
- (7) Please do not give any mechanical and/or acoustical impact to LCM. Otherwise, LCM can't be operated its full characteristics perfectly.
- (8) A screw which is fastened up the steels should be a machine screw.
(if not, it causes metallic foreign material and deal LCM a fatal blow)
- (9) Please do not set LCD on its edge.

Product Specification**9-3. ELECTROSTATIC DISCHARGE CONTROL**

Since a module is composed of electronic circuits, it is not strong to electrostatic discharge. Make certain that treatment persons are connected to ground through wrist band etc. And don't touch interface pin directly.

9-4. PRECAUTIONS FOR STRONG LIGHT EXPOSURE

Strong light exposure causes degradation of polarizer and color filter.

9-5. STORAGE

When storing modules as spares for a long time, the following precautions are necessary.

- (1) Store them in a dark place. Do not expose the module to sunlight or fluorescent light. Keep the temperature between 5°C and 35°C at normal humidity.
- (2) The polarizer surface should not come in contact with any other object.
It is recommended that they be stored in the container in which they were shipped.

9-6. HANDLING PRECAUTIONS FOR PROTECTION FILM

- (1) The protection film is attached to the bezel with a small masking tape.
When the protection film is peeled off, static electricity is generated between the film and polarizer.
This should be peeled off slowly and carefully by people who are electrically grounded and with well ion-blown equipment or in such a condition, etc.
- (2) When the module with protection film attached is stored for a long time, sometimes there remains a very small amount of glue still on the bezel after the protection film is peeled off.
- (3) You can remove the glue easily. When the glue remains on the bezel surface or its vestige is recognized, please wipe them off with absorbent cotton waste or other soft material like chamois soaked with normal-hexane.