

HannStar

Document Title	HSD101PFW2 Standard Specification	Page No.	1 / 26
Document No.	DC170-007089	Revision	1.0

TO :

Date :

Customer Acceptance Specification

Model: HSD101PFW2
-C++-

Accepted by:

Signature

Date

Note:

1. Please contact HannStar Display Corp. before designing your product based on this module specification.
2. The information contained herein is presented merely to indicate the characteristics and performance of our products. No responsibility is assumed by HannStar for any intellectual property claims or other problems that may result from application based on the module described herein.

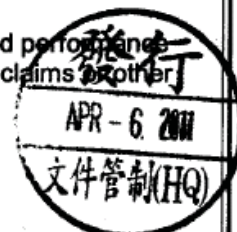

The information contained in this document is the exclusive property of HannStar Display Corporation. It shall not be disclosed, distributed or reproduced in whole or in part without written permission of HannStar Display Corporation.



HannStar Display Corp.

Document Title	HSD101PFW2 Standard Specification	Page No.	2/26
Document No.	DC170-007089	Revision	1.0

Record of Revisions

Rev.	Date	Sub-Model	Description of change
1.0	Apr, 06, 2011	C++	Formal Product Specification was first released.

The information contained in this document is the exclusive property of HannStar Display Corporation. It shall not be disclosed, distributed or reproduced in whole or in part without written permission of HannStar Display Corporation.



HannStar Display Corp.

Document Title	HSD101PFW2 Standard Specification	Page No.	3/26
Document No.	DC170-007089	Revision	1.0

Contents

1.0	General description	p.4
2.0	Absolute maximum ratings.....	p.5
3.0	Optical characteristics.....	p.6
4.0	Block diagram	p.10
5.0	Interface pin connection	p.12
6.0	Electrical characteristics	p.13
7.0	Reliability test items	p.20
8.0	Outline dimension	p.21
9.0	Lot mark	p.23
10.0	Package specification	p.24
11.0	General precaution	p.25

The information contained in this document is the exclusive property of HannStar Display Corporation. It shall not be disclosed, distributed or reproduced in whole or in part without written permission of HannStar Display Corporation.



HannStar Display Corp.

Document Title	HSD101PFW2 Standard Specification	Page No.	4/26
Document No.	DC170-007089	Revision	1.0

1.0 GENERAL DESCRIPTION

1.1 Introduction

HannStar Display model HSD101PFW2-C is a color active matrix thin film transistor (TFT) liquid crystal display (LCD) that uses amorphous silicon TFT as a switching device. This model is composed of a TFT LCD panel, a driving circuit and a back light system. This TFT LCD has a 10.1 (16:9) inch diagonally measured active display area with WSVGA (1024 horizontal by 600 vertical pixel) resolution.

1.2 Features

- 10.1 (16:9 diagonal) inch configuration
- One channel LVDS interface
- 262K color by 6 bit R.G.B signal input
- RoHS Compliance
- Halogen Free

1.3 Applications

- Mobile NB
- Digital Photo frame
- Display terminal for AV application

1.4 General information

Item	Specification	Unit
Outline Dimension	235 x 143 x 4.9 (Typ.)	mm
Display area	222.72(H) x 125.28(V)	mm
Number of Pixel	1024 RGB (H) x 600(V)	pixels
Pixel pitch	0.2175(H) x 0.2088(V)	mm
Pixel arrangement	RGB Vertical stripe	
Display mode	Normally white	
NTSC	50	%
Surface treatment	Anti-Glare (3H)	
Weight	185 (Typ.)	g
Back-light	White LED	
Power Consumption	(0.7W) (Max.)/Logic (2.7W) (Max.)/BL	W

The information contained in this document is the exclusive property of HannStar Display Corporation. It shall not be disclosed, distributed or reproduced in whole or in part without written permission of HannStar Display Corporation.



HannStar Display Corp.

Document Title	HSD101PFW2 Standard Specification	Page No.	5/26
Document No.	DC170-007089	Revision	1.0

1.5 Mechanical Information

Item		Min.	Typ.	Max.	Unit
Module Size	Horizontal (H)	234.5	235	235.5	mm
	Vertical (V)	142.5	143	143.5	mm
	Depth (D)	—	5	5.3	mm
Weight		—	185	195	g

2.0 ABSOLUTE MAXIMUM RATINGS

2.1 Electrical Absolute Rating

2.1.1 TFT LCD Module

Item	Symbol	Min.	Max.	Unit	Note
Logic Supply voltage	V_{DD}	-0.3	4.0	V	

2.1.2 Environment Absolute Rating

Item	Symbol	Min.	Max.	Unit	Note
Operating Temperature	T_{opa}	0	50	°C	
Storage Temperature	T_{stg}	-20	60	°C	

The information contained in this document is the exclusive property of HannStar Display Corporation. It shall not be disclosed, distributed or reproduced in whole or in part without written permission of HannStar Display Corporation.

Document Title	HSD101PFW2 Standard Specification	Page No.	6/26
Document No.	DC170-007089	Revision	1.0

3.0 OPTICAL CHARACTERISTICS

3.1 Optical specification

Item		Symbol	Condition	Min.	Typ.	Max.	Unit	Note
Contrast		CR	$\theta=0$ Normal viewing angle	400	500	—		(1)(2)(4)
Response time		RT		—	16	32	msec	(1)(3)
White luminance (5 point)		Y_L		240	300	—	cd/m ²	(1)(4)(5) ($I_L=18mA$)
Color chromaticity (CIE1931)	Red	R_x		(0.543)	(0.593)	(0.643)		
		R_y		(0.305)	(0.355)	(0.405)		
	Green	G_x		(0.272)	(0.322)	(0.372)		
		G_y		(0.500)	(0.550)	(0.600)		
	Blue	B_x		(0.102)	(0.152)	(0.202)		
		B_y		(0.046)	(0.096)	(0.146)		
White	W_x	0.263		0.313	0.363			
	W_y	0.279	0.329	0.379				
Viewing angle	Hor.	θ_L	$CR>10$	60	70	—		(1)(4)
		θ_R		60	70	—		
	Ver.	θ_U		40	50	—		
		θ_D		50	60	—		
Brightness uniformity		B_{UNI}	$\theta=0$ (5point)	80	—	—	%	(5)
Brightness Uniformity		B_{UNI}	$\theta=0$ (13 points)	70	—	—	%	(6)

3.2 Measuring Condition

- Measuring surrounding : dark room
- Ambient temperature : $25\pm 2^\circ C$
- 15min. warm-up time.

The information contained in this document is the exclusive property of HannStar Display Corporation. It shall not be disclosed, distributed or reproduced in whole or in part without written permission of HannStar Display Corporation.

Document Title	HSD101PFW2 Standard Specification	Page No.	7/26
Document No.	DC170-007089	Revision	1.0

3.3 Measuring Equipment

- FPM520 of Westar Display technologies, INC., which utilized SR-3 for Chromaticity and BM-5A for other optical characteristics.
- Measuring spot size : 20 ~ 21 mm

Note (1) Definition of Viewing Angle:

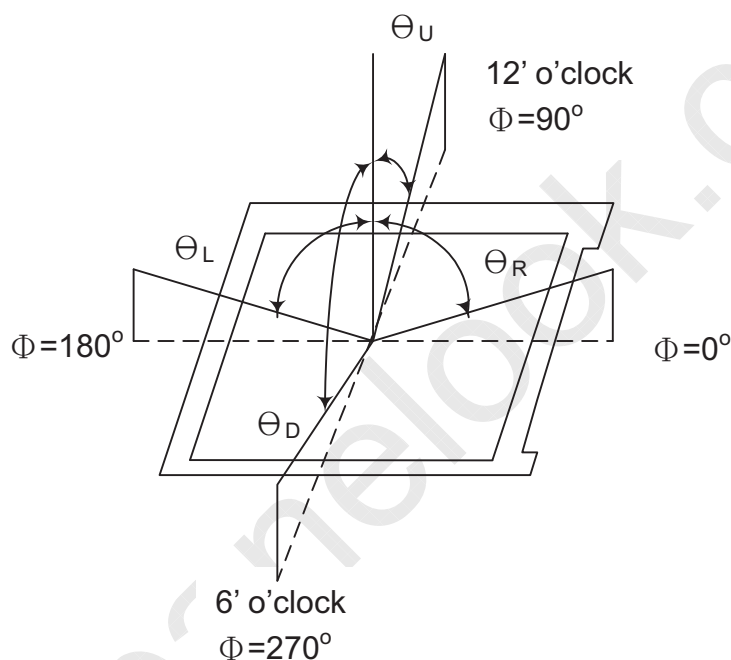

Note (2) Definition of Contrast Ratio (CR) :
measured at the center point of panel

$$CR = \frac{\text{Luminance with all pixels white}}{\text{Luminance with all pixels black}}$$

Document Title	HSD101PFW2 Standard Specification	Page No.	8/26
Document No.	DC170-007089	Revision	1.0

Note (3) Definition of Response Time : Sum of T_R and T_F

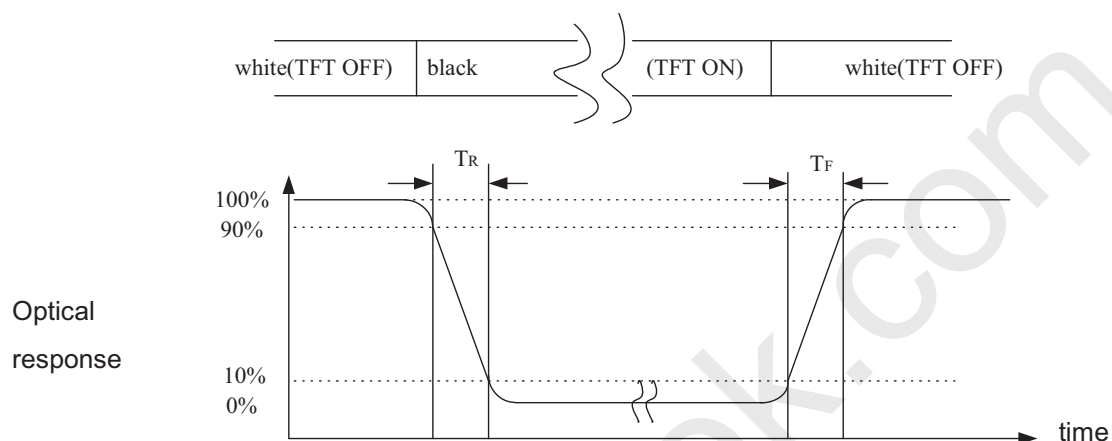

Note (4) Definition of optical measurement setup

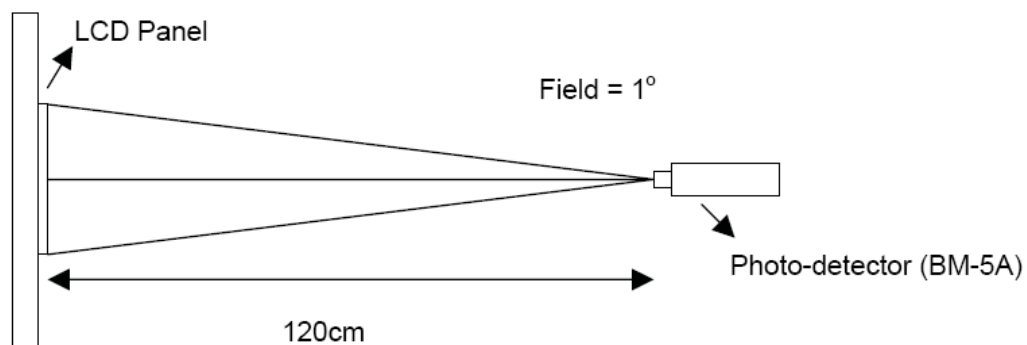

The information contained in this document is the exclusive property of HannStar Display Corporation. It shall not be disclosed, distributed or reproduced in whole or in part without written permission of HannStar Display Corporation.

Document Title	HSD101PFW2 Standard Specification	Page No.	9/26
Document No.	DC170-007089	Revision	1.0

Note (5) Definition of Average Luminance Uniformity of White (5 Point)

$$\text{Average Luminance Uniformity} = \frac{Y_1 + Y_2 + Y_3 + Y_4 + Y_5}{5}$$

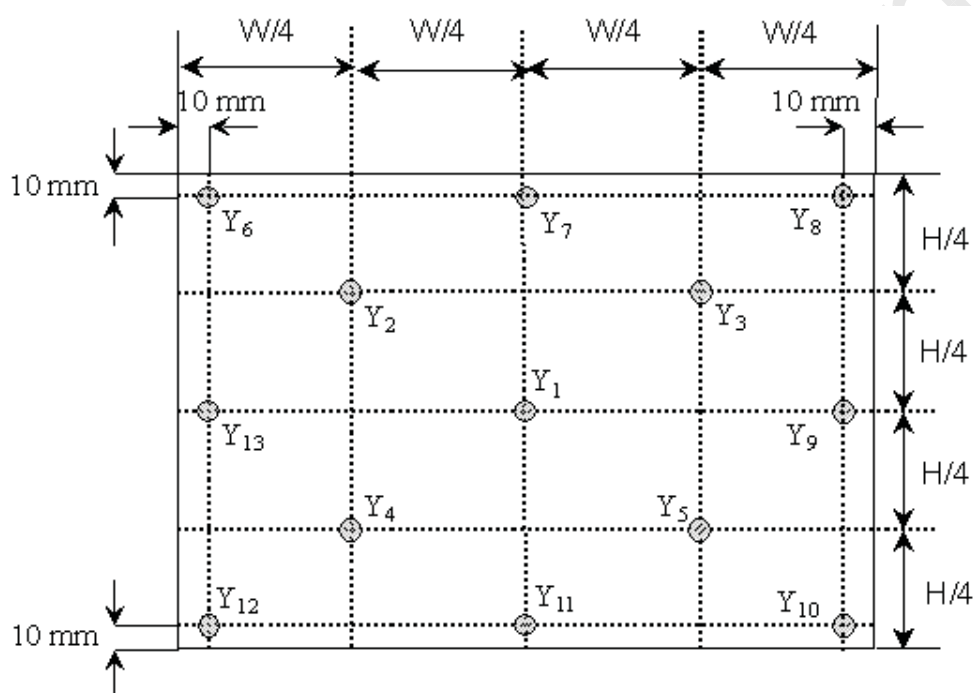

Note (6) Definition of brightness uniformity

$$\text{Luminance uniformity(5 points)} = \frac{(\text{Min Luminance of 5 points})}{(\text{Max Luminance of 5 points})} \times 100\%$$

$$\text{Luminance uniformity(13 points)} = \frac{(\text{Min Luminance of 13 points})}{(\text{Max Luminance of 13 points})} \times 100\%$$



HannStar Display Corp.

Document Title	HSD101PFW2 Standard Specification	Page No.	10/26
Document No.	DC170-007089	Revision	1.0

4.0 BLOCK DIAGRAM

4.1 TFT LCD Module:

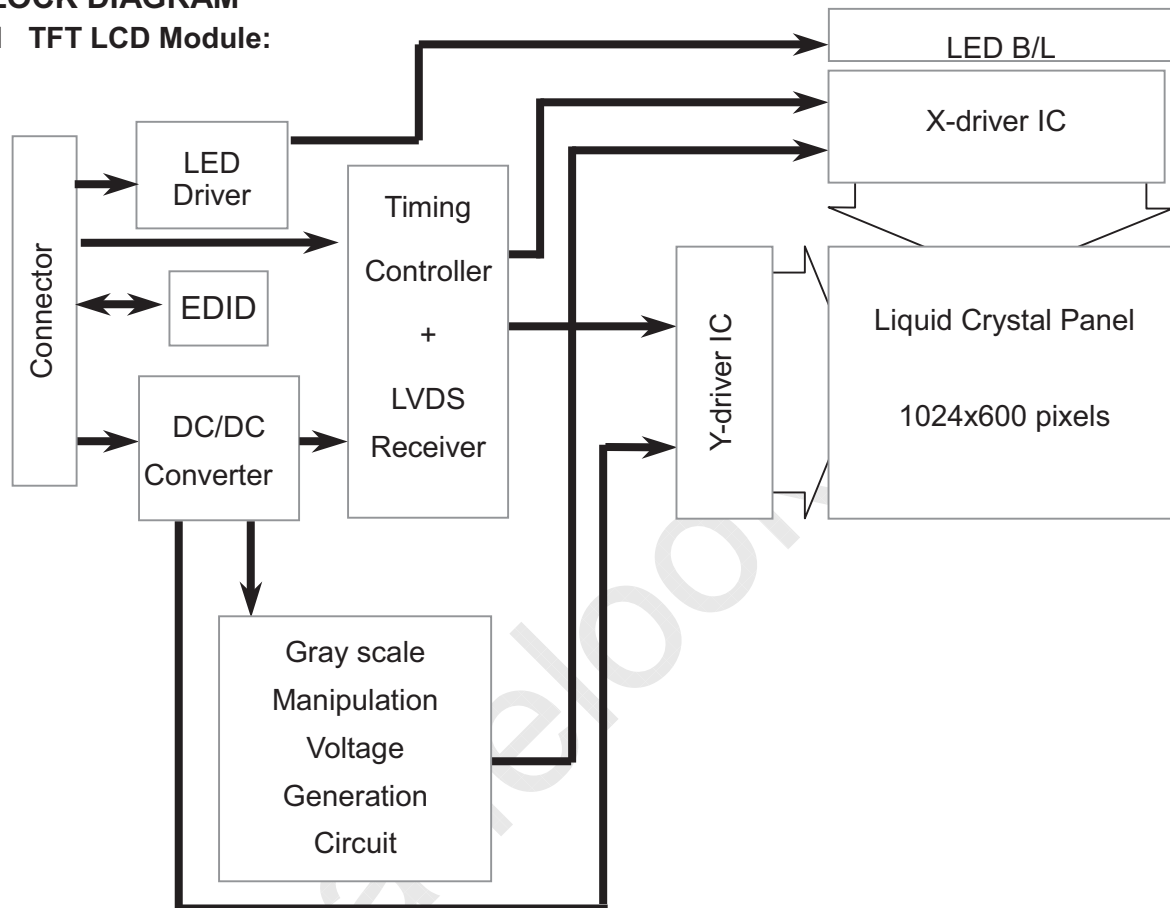

4.2 Pixel Format

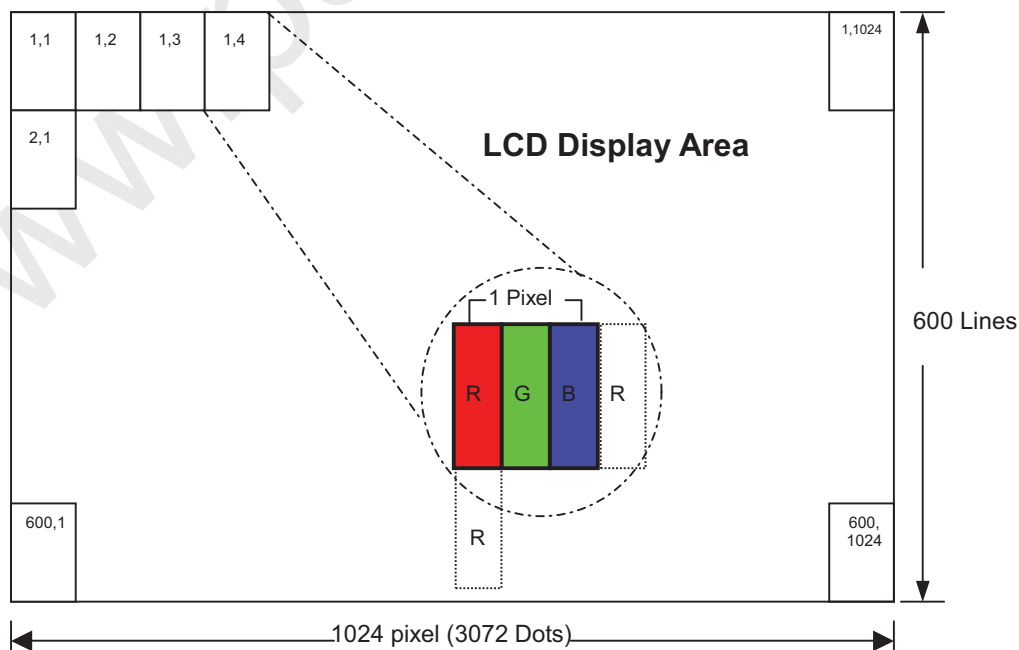

The information contained in this document is the exclusive property of HannStar Display Corporation. It shall not be disclosed, distributed or reproduced in whole or in part without written permission of HannStar Display Corporation.



HannStar Display Corp.

Document Title	HSD101PFW2 Standard Specification	Page No.	11/26
Document No.	DC170-007089	Revision	1.0

4.3 Relationship Between Displayed Color and Input

	Display	MSB						LSB						Gray scale level							
		R5	R4	R3	R2	R1	R0	G5	G4	G3	G2	G1	G0		B5	B4	B3	B2	B1	B0	
Basic color	Black	L	L	L	L	L	L	L	L	L	L	L	L	L	L	L	L	L	L	-	
	Blue	L	L	L	L	L	L	L	L	L	L	L	L	H	H	H	H	H	H	-	
	Green	L	L	L	L	L	L	H	H	H	H	H	H	L	L	L	L	L	L	-	
	Light Blue	L	L	L	L	L	L	H	H	H	H	H	H	H	H	H	H	H	H	-	
	Red	H	H	H	H	H	H	L	L	L	L	L	L	L	L	L	L	L	L	-	
	Purple	H	H	H	H	H	H	L	L	L	L	L	L	H	H	H	H	H	H	-	
	Yellow	H	H	H	H	H	H	H	H	H	H	H	H	L	L	L	L	L	L	-	
	White	H	H	H	H	H	H	H	H	H	H	H	H	H	H	H	H	H	H	-	
Gray scale of Red	Black	L	L	L	L	L	L	L	L	L	L	L	L	L	L	L	L	L	L	L0	
	Dark ↑ ↓ Light	L	L	L	L	L	H	L	L	L	L	L	L	L	L	L	L	L	L	L1	
		L	L	L	L	H	L	L	L	L	L	L	L	L	L	L	L	L	L	L2	
		⋮	⋮	⋮	⋮	⋮	⋮	⋮	⋮	⋮	⋮	⋮	⋮	⋮	⋮	⋮	⋮	⋮	⋮	⋮	L3...L60
		H	H	H	H	L	H	L	L	L	L	L	L	L	L	L	L	L	L	L61	
	H	H	H	H	H	L	L	L	L	L	L	L	L	L	L	L	L	L	L62		
	Red	H	H	H	H	H	H	L	L	L	L	L	L	L	L	L	L	L	L	Red L63	
	Gray scale of Green	Black	L	L	L	L	L	L	L	L	L	L	L	L	L	L	L	L	L	L	L0
Dark ↑ ↓ Light		L	L	L	L	L	L	L	L	L	L	L	H	L	L	L	L	L	L	L1	
		L	L	L	L	L	L	L	L	L	L	H	L	L	L	L	L	L	L	L2	
		⋮	⋮	⋮	⋮	⋮	⋮	⋮	⋮	⋮	⋮	⋮	⋮	⋮	⋮	⋮	⋮	⋮	⋮	⋮	L3...L60
		L	L	L	L	L	L	H	H	H	H	L	H	L	L	L	L	L	L	L61	
L		L	L	L	L	L	H	H	H	H	H	L	L	L	L	L	L	L	L62		
Green		L	L	L	L	L	L	H	H	H	H	H	H	L	L	L	L	L	L	Green L63	
Gray scale of Blue		Black	L	L	L	L	L	L	L	L	L	L	L	L	L	L	L	L	L	L	L0
	Dark ↑ ↓ Light	L	L	L	L	L	L	L	L	L	L	L	L	L	L	L	L	L	H	L1	
		L	L	L	L	L	L	L	L	L	L	L	L	L	L	L	L	H	L	L2	
		⋮	⋮	⋮	⋮	⋮	⋮	⋮	⋮	⋮	⋮	⋮	⋮	⋮	⋮	⋮	⋮	⋮	⋮	⋮	L3...L60
		L	L	L	L	L	L	L	L	L	L	L	L	H	H	H	H	L	H	L61	
	L	L	L	L	L	L	L	L	L	L	L	L	H	H	H	H	H	L	L62		
	Blue	L	L	L	L	L	L	L	L	L	L	L	L	H	H	H	H	H	Blue L63		
	Gray scale of White & Black	Black	L	L	L	L	L	L	L	L	L	L	L	L	L	L	L	L	L	L	L0
Dark ↑ ↓ Light		L	L	L	L	L	H	L	L	L	L	L	H	L	L	L	L	L	H	L1	
		L	L	L	L	H	L	L	L	L	L	H	L	L	L	L	L	H	L	L2	
		⋮	⋮	⋮	⋮	⋮	⋮	⋮	⋮	⋮	⋮	⋮	⋮	⋮	⋮	⋮	⋮	⋮	⋮	⋮	L3...L60
		H	H	H	H	L	H	H	H	H	H	L	H	H	H	H	H	L	H	L61	
H		H	H	H	H	L	H	H	H	H	H	L	H	H	H	H	H	L	L62		
White		H	H	H	H	H	H	H	H	H	H	H	H	H	H	H	H	H	H	White L63	

The information contained in this document is the exclusive property of HannStar Display Corporation. It shall not be disclosed, distributed or reproduced in whole or in part without written permission of HannStar Display Corporation.



HannStar Display Corp.

Document Title	HSD101PFW2 Standard Specification	Page No.	12/26
Document No.	DC170-007089	Revision	1.0

5.0 INTERFACE PIN CONNECTION

5.1 TFT LCD Module : CN1 (Input signal): FI-XB30SL-HF10(JAE or equivalent)

Pin No.	Signal	Description
1	GND	Ground
2	VCC	(+)3.3V Power
3	VCC	(+)3.3V Power
4	V_EDID	3.3V Power for NB
5	ADJ	Adjust for LED brightness
6	CLK_EDID	EDID Clock for NB
7	DATA_EDID	EDID Data for NB
8	RXIN0-	LVDS Signal(-)-----channel 0
9	RXIN0+	LVDS Signal(+)------channel 0
10	GND	Ground
11	RXIN1-	LVDS Signal(-)-----channel 1
12	RXIN1+	LVDS Signal(+)------channel 1
13	GND	Ground
14	RXIN2-	LVDS Signal(-)-----channel 2
15	RXIN2+	LVDS Signal(+)------channel 2
16	GND	Ground
17	RXCLKIN-	LVDS Clock Signal(-)
18	RXCLKIN+	LVDS Clock Signal(+)
19	GND	Ground
20	NC	NC
21	NC	NC
22	GND	Ground
23	GND	Ground
24	V_LED	Power Supply for LED(+) 5V
25	V_LED	Power Supply for LED(+) 5V
26	V_LED	Power Supply for LED(+) 5V
27	NC	NC
28	NC	NC
29	NC	NC
30	NC	NC

Note : The brightness of LCD panel could be changed by adjusting ADJ

The information contained in this document is the exclusive property of HannStar Display Corporation. It shall not be disclosed, distributed or reproduced in whole or in part without written permission of HannStar Display Corporation.



HannStar Display Corp.

Document Title	HSD101PFW2 Standard Specification	Page No.	13/26
Document No.	DC170-007089	Revision	1.0

6.0 ELECTRICAL CHARACTERISTICS

6.1 TFT LCD Module

Item	Symbol	Min.	Typ.	Max.	Unit	Note
Supply Voltage	V_{DD}	3.0	3.3	3.6	V	Note (1)
Current of power supply	I_{DD}	-	(0.190)	-	A	$V_{DD}=3.3V$ · L0 pattern $T_a=25^{\circ}C$ $f_v=60Hz$
Inrush current	I_{RUSH}	-	-	1.50	A	Note (2)

Note (1): V_{DD} -dip condition:

When V_{DD} operating within $2.7V \leq V_{DD} < 3.0V$ · $t_d \leq 10ms$, the display may momentarily become abnormal.

$V_{DD} < 2.7V$, V_{DD} dip condition should also follow the Power On/Off conditions for supply voltage.

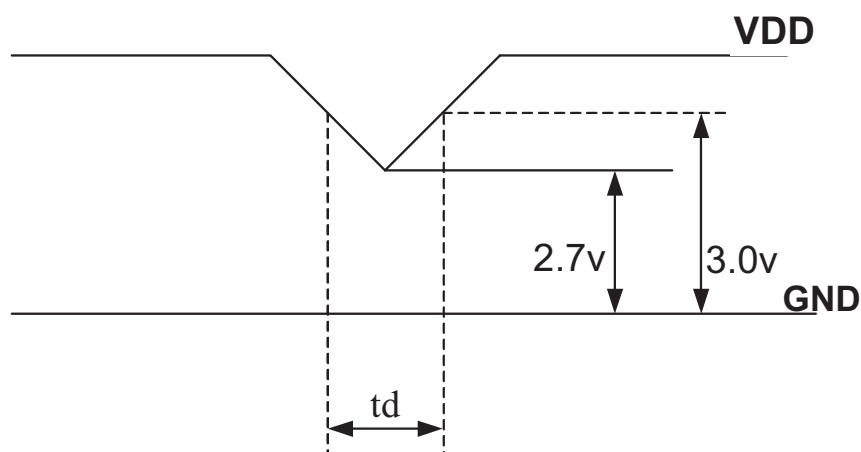

The information contained in this document is the exclusive property of HannStar Display Corporation. It shall not be disclosed, distributed or reproduced in whole or in part without written permission of HannStar Display Corporation.

Document Title	HSD101PFW2 Standard Specification	Page No.	14/26
Document No.	DC170-007089	Revision	1.0

Note : (2) Power on Inrush current test circuit

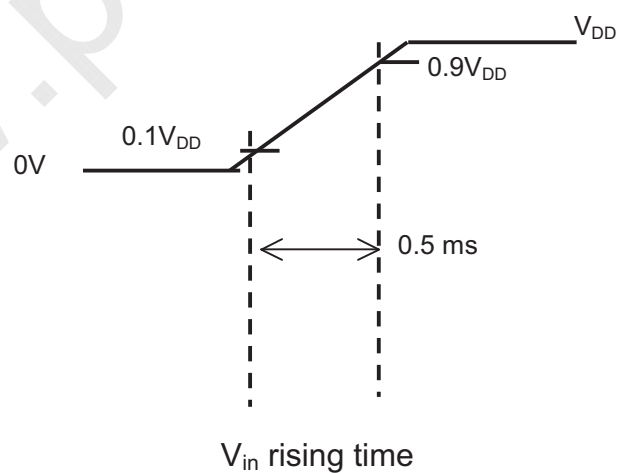
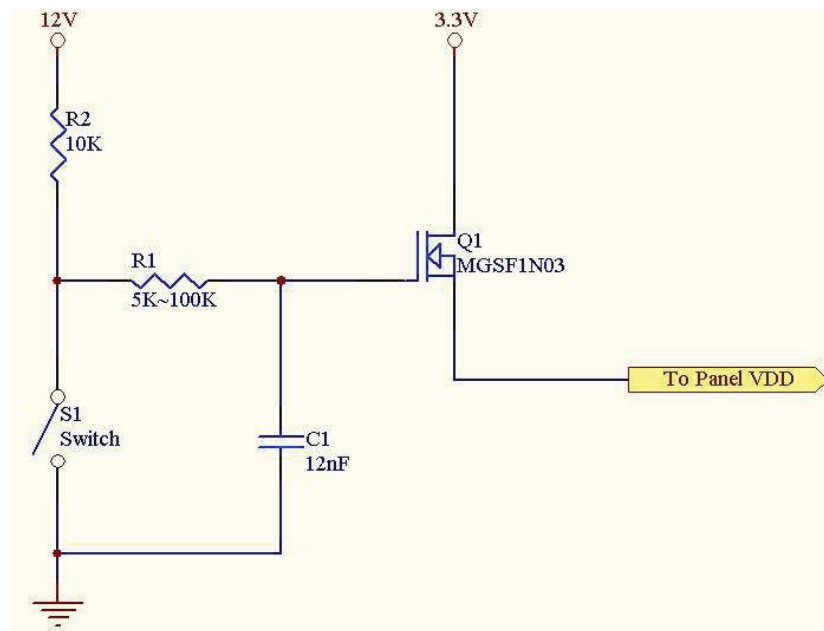

The information contained in this document is the exclusive property of HannStar Display Corporation. It shall not be disclosed, distributed or reproduced in whole or in part without written permission of HannStar Display Corporation.

Document Title	HSD101PFW2 Standard Specification	Page No.	15/26
Document No.	DC170-007089	Revision	1.0

6.2 Switching Characteristics for LVDS Receiver

Item	Symbol	Min.	Typ.	Max.	Unit	Conditions
Differential Input High Threshold	V_{th}	—	—	100	mV	$V_{CM}=1.2V$
Differential Input Low Threshold	V_{tl}	-100	—	—	mV	
Input Current	I_{IN}	-10	—	+10	uA	
Differential input Voltage	$ V_{ID} $	0.1	—	0.6	V	
Common Mode Voltage Offset	V_{CM}	$(V_{ID} /2)$	1.25	$2.4-(V_{ID} /2)$	V	

6.3 Bit Mapping & Interface Definition

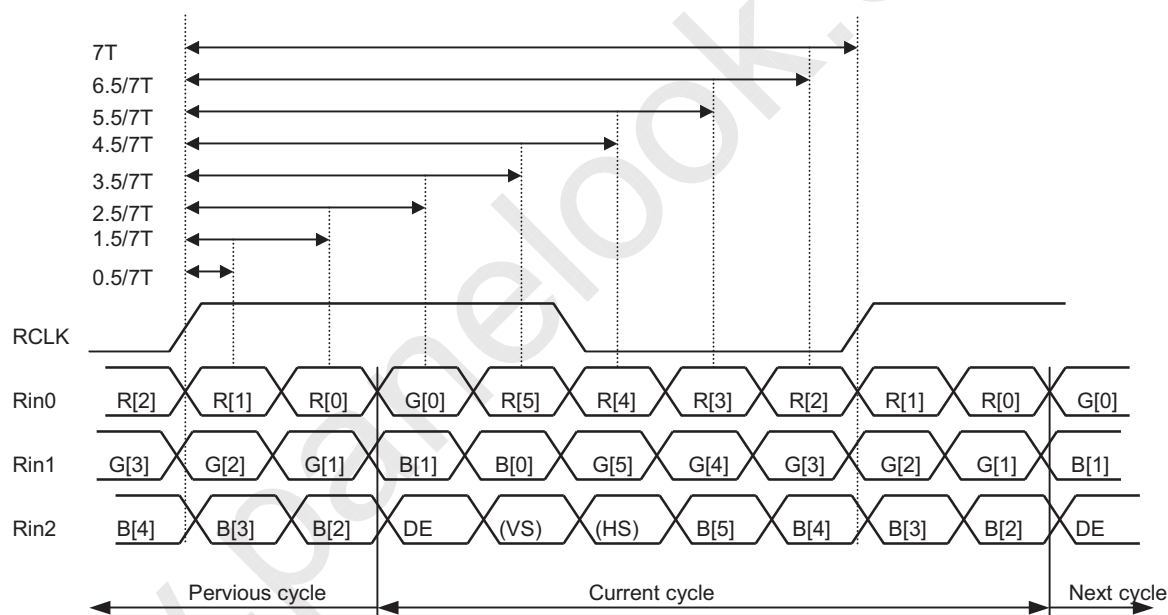

LVDS Receiver Input Timing Definition
for 6bits LVDS input

Document Title	HSD101PFW2 Standard Specification	Page No.	16/26
Document No.	DC170-007089	Revision	1.0

6.4 Interface Timing (DE mode)

Item	Symbol	Min.	Typ.	Max.	Unit
Frame Rate	--	55	60	65	Hz
Frame Period	t1	612	625	680	line
Vertical Display Time	t2	600	600	600	line
Vertical Blanking Time	t3	12	25	80	line
1 Line Scanning Time	t4	1160	1200	1510	clock
Horizontal Display Time	t5	1024	1024	1024	clock
Horizontal Blanking Time	t6	136	176	486	clock
Clock Rate	t7	39	45	61.6	MHz

Timing Diagram of Interface Signal (DE mode)

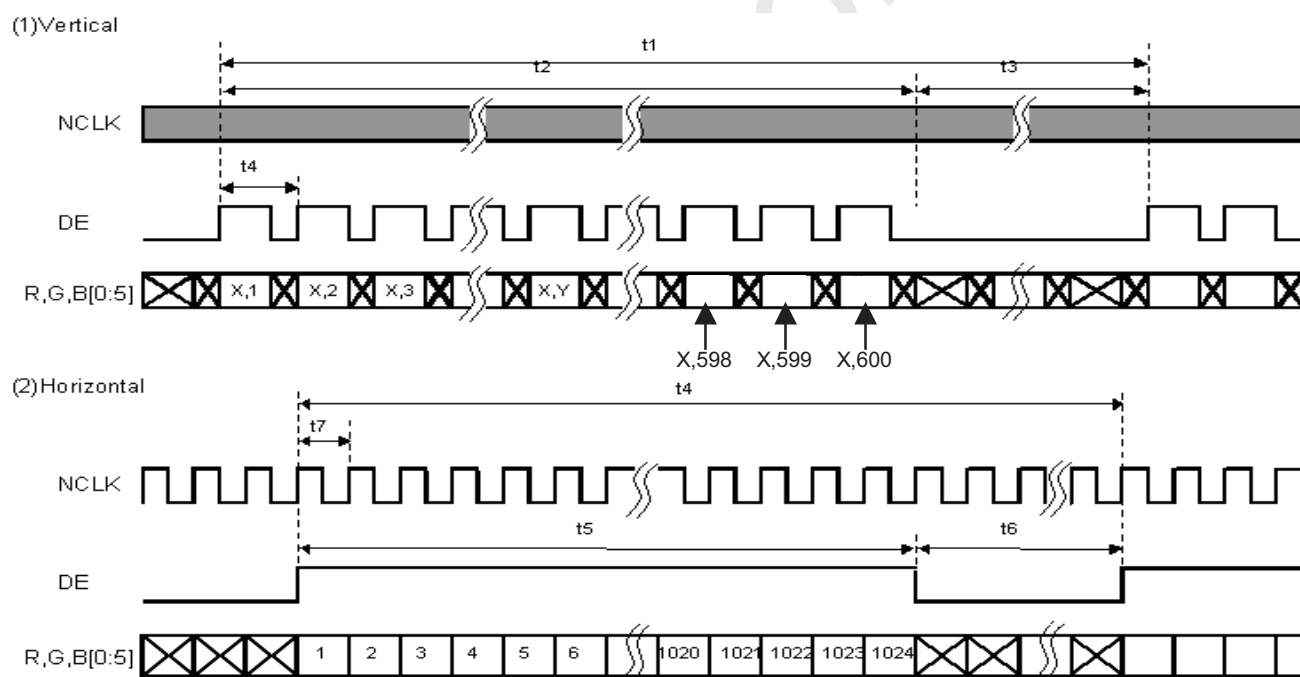

The information contained in this document is the exclusive property of HannStar Display Corporation. It shall not be disclosed, distributed or reproduced in whole or in part without written permission of HannStar Display Corporation.

Document Title	HSD101PFW2 Standard Specification	Page No.	17/26
Document No.	DC170-007089	Revision	1.0

6.5 Power On / Off Sequence

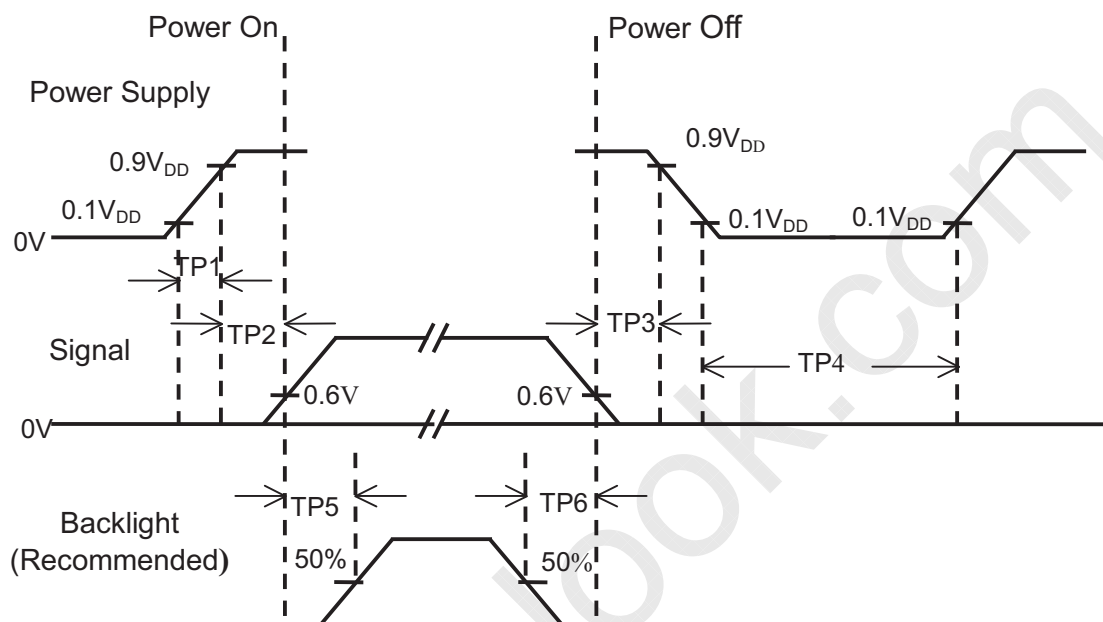

Item	Min.	Typ.	Max.	Unit	Remark
TP1	0.5	--	10	msec	
TP2	0	--	50	msec	
TP3	0	--	50	msec	
TP4	500	--	--	msec	
TP5	200	--	--	msec	
TP6	200	--	--	msec	

- Note :**
- (1) The supply voltage of the external system for the module input should be the same as the definition of V_{DD} .
 - (2) Apply the lamp voltage within the LCD operation range. When the back-light turns on before the LCD operation or the LCD turns off before the back-light turns off, the display may momentarily become white.
 - (3) In case of $V_{DD} = \text{off level}$, please keep the level of input signal on the low or keep a high impedance.
 - (4) TP4 should be measured after the module has been fully discharged between power off and on period.
 - (5) Interface signal shall not be kept at high impedance when the power is on.

Document Title	HSD101PFW2 Standard Specification	Page No.	18/26
Document No.	DC170-007089	Revision	1.0

6.6 Backlight Unit

Parameter	Symbol	Min	Typ	Max	Units	Condition
LED Current	I_F	--	(20)	(21)	mA	Ta=25°C
LED Voltage	V_F	3.0	3.2	3.4	Volt	Ta=25°C
LED Power consumption	P_{LED}	--	(2.12)	(2.36)	Watt	Ta=25°C Note (1)
LED Life-Time	N/A	10,000	--	--	Hour	Ta=25°C $I_F=18mA$ Note (2)

Note (1): Calculator value for reference $P=I_F \times V_F \times N$ (LED Qty')

Note (2): The LED lifetime defines as the estimated time to 50% degradation of final luminous.

6.7 LED Driver

6.7.1 Absolute Maximum Ratings

Item	Symbol	Min.	Max.	Unit	Note
LED Power Supply voltage	V_{LED}	-0.3	6	Volt	
LED_EN, PWM pin Voltage	V_{EN}, V_{PWM}	--	5.5	Volt	

6.7.2 DC Electrical Characteristics

Parameter	Symbol	Min	Typ	Max	Units	Remark
LED Power Supply Voltage	V_{LED}	4.5	--	5.5	Volt	
PWM High Threshold	V_{PWMH}	3.0	--	--	Volt	
PWM Low Threshold	V_{PWML}	--	--	0.2	Volt	
PWM Frequency	F_{PWM}	18	--	22	KHz	
PWM Duty Cycle	T_D	20	--	--	%	Note(1)

The information contained in this document is the exclusive property of HannStar Display Corporation. It shall not be disclosed, distributed or reproduced in whole or in part without written permission of HannStar Display Corporation.

Document Title	HSD101PFW2 Standard Specification	Page No.	19/26
Document No.	DC170-007089	Revision	1.0

Note: PWM Duty Cycle. Pulse duty the bigger the brighter.

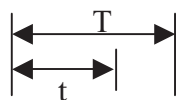

$$\text{Duty Cycle } T_D = (t / T) \times 100\%$$

The information contained in this document is the exclusive property of HannStar Display Corporation. It shall not be disclosed, distributed or reproduced in whole or in part without written permission of HannStar Display Corporation.



HannStar Display Corp.

Document Title	HSD101PFW2 Standard Specification	Page No.	20/26
Document No.	DC170-007089	Revision	1.0

7.0 Reliability test items

No.	Item	Conditions	Remark
1	High Temperature Storage	Ta=+60°C, 240hrs	
2	Low Temperature Storage	Ta=-20°C, 240hrs	
3	High Temperature Operation	Ta=+50°C, 500hrs	
4	Low Temperature Operation	Ta=0°C, 500hrs	
5	Thermal Cycling Test (non operation)	-20°C(30min)→+60°C(30min),100 cycles	
6	Vibration	Sine Wave 1.5G, 5~500Hz, XYZ 30min/each direction	
7	Shock	Half-Sine, 200G, 2ms, ±XYZ, 1time	

Storage / Operating temperature

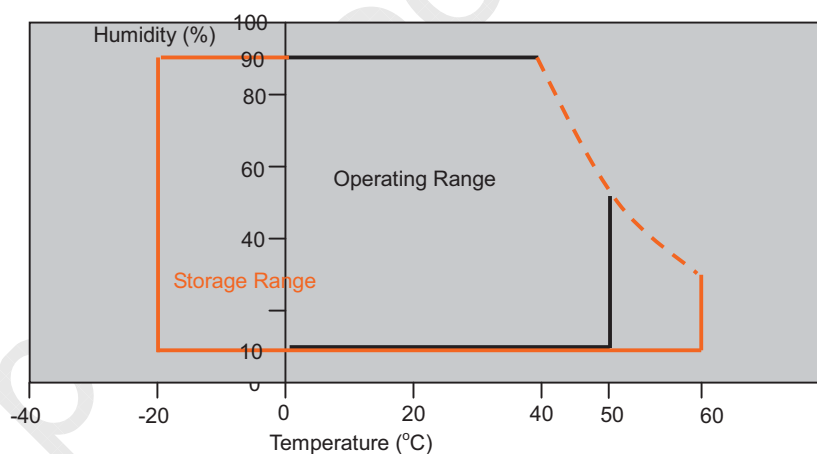

Note .Max wet bulb temp.=39°C

The information contained in this document is the exclusive property of HannStar Display Corporation. It shall not be disclosed, distributed or reproduced in whole or in part without written permission of HannStar Display Corporation.

Document Title	HSD101PFW2 Standard Specification	Page No.	21/26
Document No.	DC170-007089	Revision	1.0

8.0 OUTLINE DIMENSION

8.1 Front View Outline Dimension

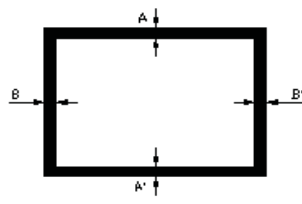
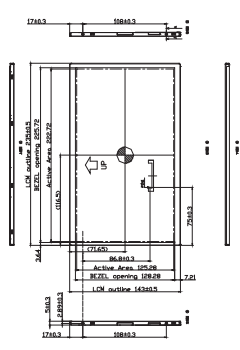
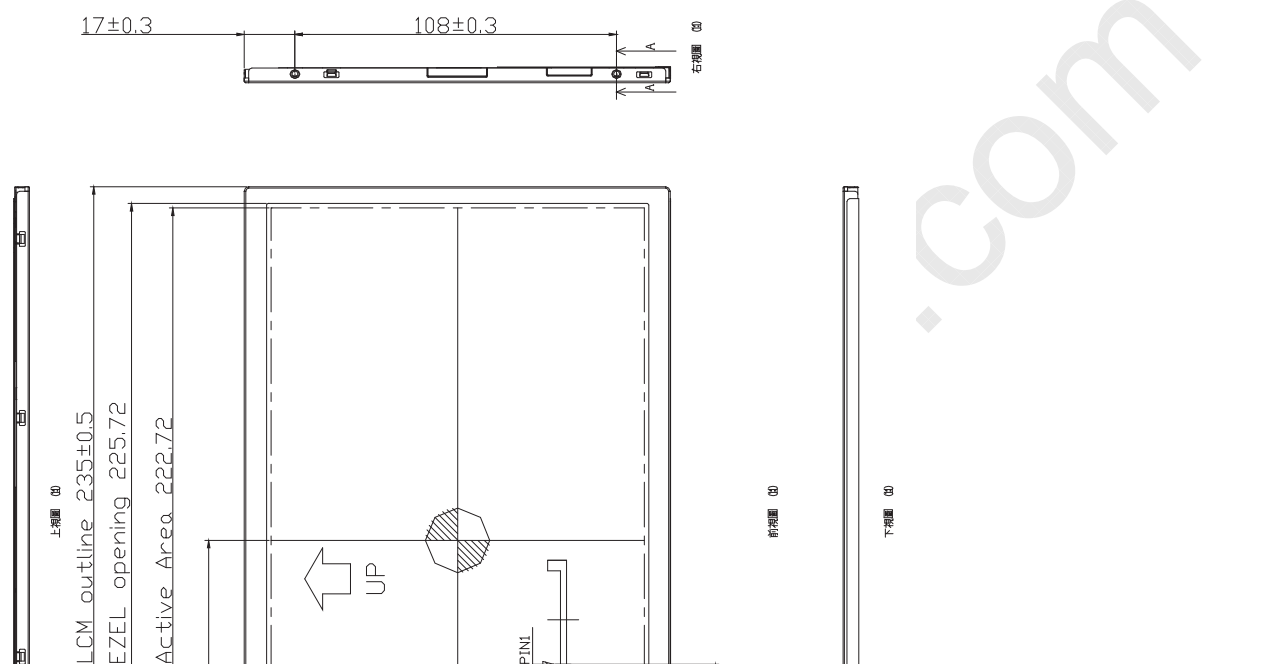

BM Assembly Tolerance

$$|A-A'| \leq 1 \text{ (mm)}$$

$$|B-B'| \leq 1 \text{ (mm)}$$

The information contained in this document is the exclusive property of HannStar Display Corporation. It shall not be disclosed, distributed or reproduced in whole or in part without written permission of HannStar Display Corporation.

Document Title	HSD101PFW2 Standard Specification	Page No.	22/26
Document No.	DC170-007089	Revision	1.0

8.2 Back View Outline Dimension

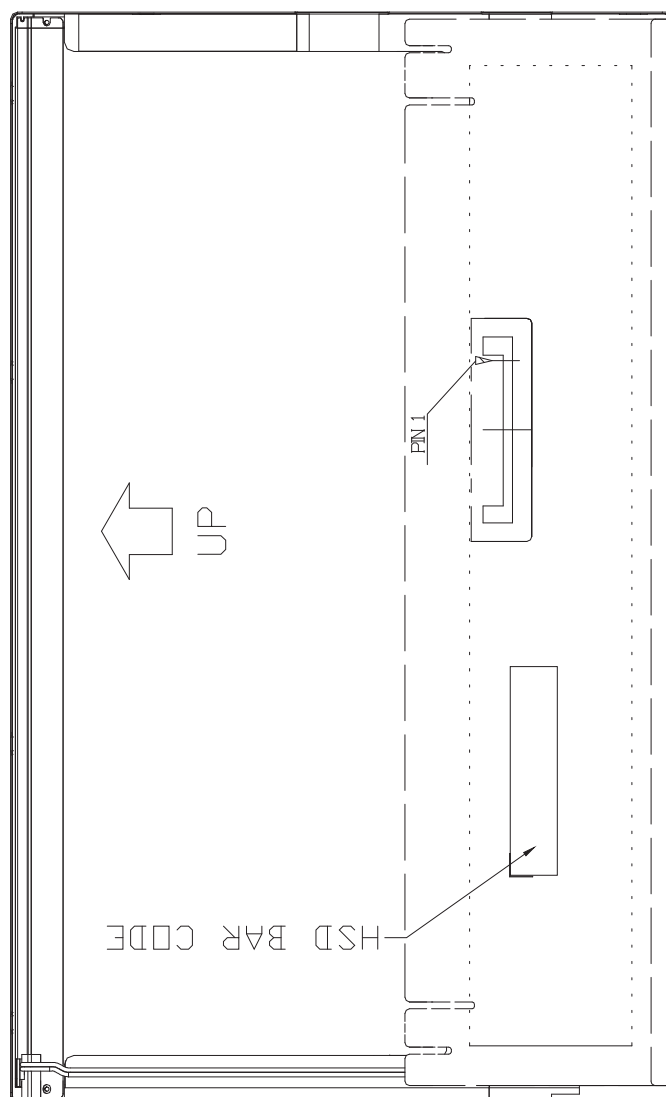

The information contained in this document is the exclusive property of HannStar Display Corporation. It shall not be disclosed, distributed or reproduced in whole or in part without written permission of HannStar Display Corporation.

Document Title	HSD101PFW2 Standard Specification	Page No.	23/26
Document No.	DC170-007089	Revision	1.0

9.0 LOT MARK

9.1 Lot Mark

1	2	3	4	5	6	7	8	9	10	11	12	13	14	15
---	---	---	---	---	---	---	---	---	----	----	----	----	----	----

Code 1,2,3,4,5,6: HannStar internal flow control code.

Code 7: production location.

Code 8: production year.

Code 9: production month.

Code 10,11,12,13,14,15: serial number.

Note (1) Production Year

Year	2003	2004	2005	2006	2007	2008	2009	2010	2011	2012
Mark	3	4	5	6	7	8	9	0	1	2

Note (2) Production Month

Month	Jan.	Feb.	Mar.	Apr.	May.	Jun.	Jul.	Aug.	Sep.	Oct	Nov.	Dec.
Mark	1	2	3	4	5	6	7	8	9	A	B	C

9.2 Location of Lot Mark

- (1) Location : The label is attached to the backside of the LCD module. See Product back view. (Section 8.0 : OUTLINE DIMENSION)
- (2) Detail of the Mark : As attached below
- (3) This is subject to change without prior notice.

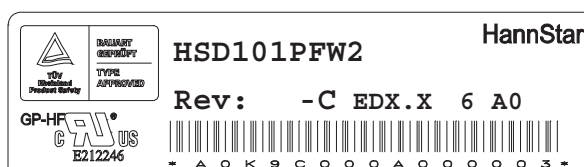

The information contained in this document is the exclusive property of HannStar Display Corporation. It shall not be disclosed, distributed or reproduced in whole or in part without written permission of HannStar Display Corporation.

Document Title	HSD101PFW2 Standard Specification	Page No.	24/26
Document No.	DC170-007089	Revision	1.0

10.0 PACKAGE SPECIFICATION

10.1 Packing form

LCM Model	LCM Qty. in the box	Inner Box Size (mm)	Notice
HSD101PFW2-C	50 pcs/box	(460 x 316 x 321 ^H)	

10.2 Packing assembly drawings

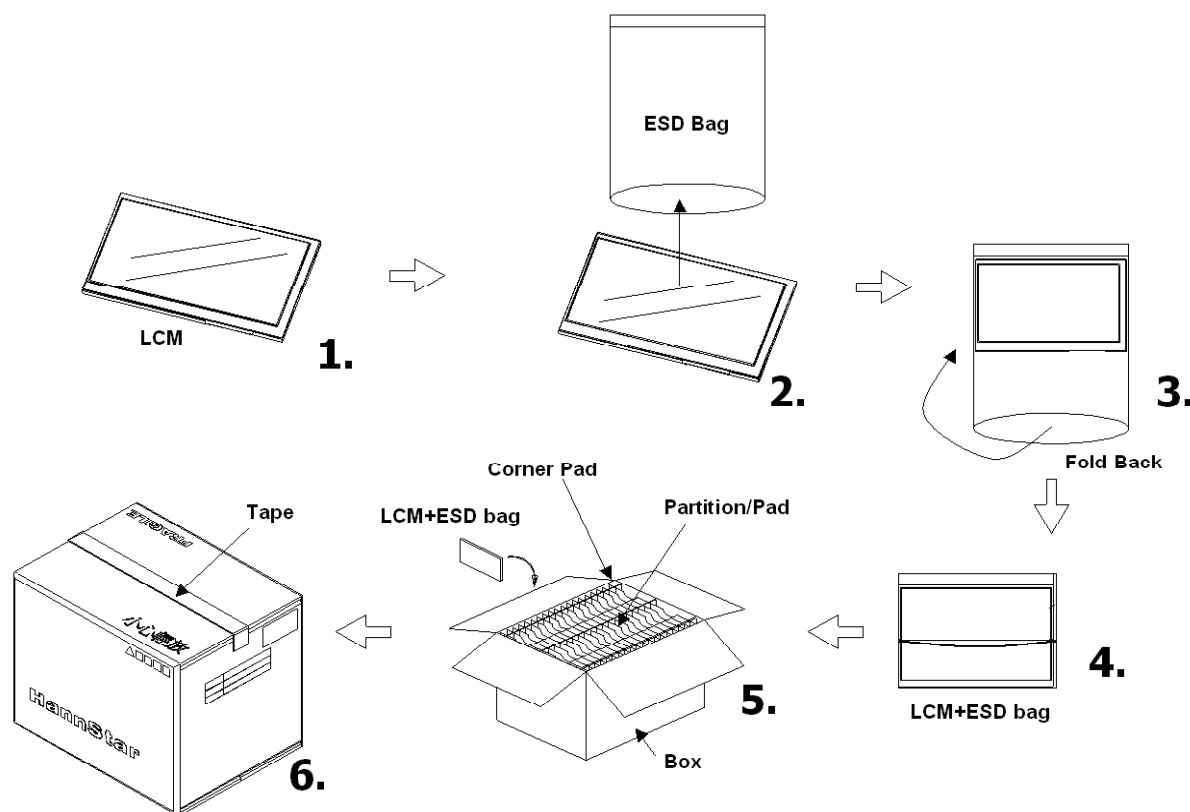

HSD101PFW2-C	Material	Notice
Box	Corrugated Paper Board	(AB Flute)
Partition/Pad	Corrugated Paper Board	(B Flute)
Corner Pad	Corrugated Paper Board	(AB Flute)
ESD bag	PE	--

The information contained in this document is the exclusive property of HannStar Display Corporation. It shall not be disclosed, distributed or reproduced in whole or in part without written permission of HannStar Display Corporation.

Document Title	HSD101PFW2 Standard Specification	Page No.	25/26
Document No.	DC170-007089	Revision	1.0

11.0 GENERAL PRECAUTION

11.1 Use Restriction

This product is not authorized for use in life supporting systems, aircraft navigation control systems, military systems and any other application where performance failure could be life-threatening or otherwise catastrophic.

11.2 Disassembling or Modification

Do not disassemble or modify the module. It may damage sensitive parts inside LCD module, and may cause scratches or dust on the display. HannStar does not warrant the module, if customers disassemble or modify the module.

11.3 Breakage of LCD Panel

11.3.1. If LCD panel is broken and liquid crystal spills out, do not ingest or inhale liquid crystal, and do not contact liquid crystal with skin.

11.3.2. If liquid crystal contacts mouth or eyes, rinse out with water immediately.

11.3.3. If liquid crystal contacts skin or cloths, wash it off immediately with alcohol and rinse thoroughly with water.

11.3.4. Handle carefully with chips of glass that may cause injury, when the glass is broken.

11.4 Electric Shock

11.4.1. Disconnect power supply before handling LCD module.

11.4.2. Do not pull or fold the LED cable.

11.4.3. Do not touch the parts inside LCD modules and the fluorescent LED's connector or cables in order to prevent electric shock.

11.5 Absolute Maximum Ratings and Power Protection Circuit

11.5.1. Do not exceed the absolute maximum rating values, such as the supply voltage variation, input voltage variation, variation in parts' parameters, environmental temperature, etc., otherwise LCD module may be damaged.

11.5.2. Please do not leave LCD module in the environment of high humidity and high temperature for a long time.

11.5.3. It's recommended to employ protection circuit for power supply.

11.6 Operation

11.6.1 Do not touch, push or rub the polarizer with anything harder than HB pencil lead.

11.6.2 Use fingerstalls of soft gloves in order to keep clean display quality, when persons handle the LCD module for incoming inspection or assembly.

11.6.3 When the surface is dusty, please wipe gently with absorbent cotton or other soft material.

The information contained in this document is the exclusive property of HannStar Display Corporation. It shall not be disclosed, distributed or reproduced in whole or in part without written permission of HannStar Display Corporation.



HannStar Display Corp.

Document Title	HSD101PFW2 Standard Specification	Page No.	26/26
Document No.	DC170-007089	Revision	1.0

11.6.4 Wipe off saliva or water drops as soon as possible. If saliva or water drops contact with polarizer for a long time, they may causes deformation or color fading.

11.6.5 When cleaning the adhesives, please use absorbent cotton wetted with a little petroleum benzine or other adequate solvent.

11.7 Mechanism

Please mount LCD module by using mounting holes arranged in four corners tightly.

11.8 Static Electricity

11.8.1 Protection film must remove very slowly from the surface of LCD module to prevent from electrostatic occurrence.

11.8.2 Because LCD module use CMOS-IC on circuit board and TFT-LCD panel, it is very weak to electrostatic discharge. Please be careful with electrostatic discharge. Persons who handle the module should be grounded through adequate methods.

11.9 Strong Light Exposure

The module shall not be exposed under strong light such as direct sunlight. Otherwise, display characteristics may be changed.

11.10 Disposal

When disposing LCD module, obey the local environmental regulations.

The information contained in this document is the exclusive property of HannStar Display Corporation. It shall not be disclosed, distributed or reproduced in whole or in part without written permission of HannStar Display Corporation.