



(V) Preliminary Specifications
() Final Specifications

Module	15 Inch Color TFT-LCD
Model Name	G150XTN05.1

Customer	Date
<div style="text-align: center; margin-top: 100px;">Checked & Approved by</div> <div style="text-align: center; margin-top: 20px;"> _____ </div>	
Note: This Specification is subject to change without notice.	

Approved by	Date
_____ Vito Huang	_____ 2013/7/9
Prepared by	
_____ Wennie Lee	_____ 2013/7/9
General Display Business Division / AU Optronics corporation	



Contents

1. Operating Precautions	4
2. General Description	5
2.1 Display Characteristics	5
2.2 Optical Characteristics	6
3. Functional Block Diagram	9
4. Absolute Maximum Ratings	10
4.1 Absolute Ratings of TFT LCD Module.....	10
4.2 Absolute Ratings of Environment	10
5. Electrical Characteristics	11
5.1 TFT LCD Module.....	11
5.2 Backlight Unit	13
6. Signal Characteristic	14
6.1 Pixel Format Image	14
6.2 Scanning Direction	14
6.3 Signal Description	15
6.4 The Input Data Format	16
6.5 Interface Timing.....	17
6.6 Power ON/OFF Sequence	18
7. Connector & Pin Assignment	19
7.1 TFT LCD Module: LVDS Connector	19
7.2 Backlight Unit: LED Driver Board Connector	20
7.2 Backlight Unit: LED Driver Board Connector	21
7.3 LED Driver Board Connector Pin Assignment.....	21
7.4 Backlight Unit: LED Connector.....	22
7.5 LED Connector Pin Assignment	22
8. Reliability Test Criteria	23
9. Mechanical Characteristics	24
9.1 LCM Outline Dimension (Front View).....	24
9.2 LCM Outline Dimension (Rear View)	24
10. Label and Packaging	25
10.1 Shipping Label (on the rear side of TFT-LCD display).....	25
10.2 Carton Package	25
11 Safety	26
11.1 Sharp Edge Requirements	26
11.2 Materials.....	26
11.3 Capacitors	26
11.4 National Test Lab Requirement	26

**Record of Revision**

Version and Date	Page	Old description	New Description
0.0 2013/7/9	All	First Edition	



1. Operating Precautions

- 1) Since front polarizer is easily damaged, please be cautious and not to scratch it.
- 2) Be sure to turn off power supply when inserting or disconnecting from input connector.
- 3) Wipe off water drop immediately. Long contact with water may cause discoloration or spots.
- 4) When the panel surface is soiled, wipe it with absorbent cotton or soft cloth.
- 5) Since the panel is made of glass, it may be broken or cracked if dropped or bumped on hard surface.
- 6) Since CMOS LSI is used in this module, take care of static electricity and insure human earth when handling.
- 7) Do not open nor modify the module assembly.
- 8) Do not press the reflector sheet at the back of the module to any direction.
- 9) In case if a module has to be put back into the packing container slot after it was taken out from the container, do not press the center of the LED Reflector edge. Instead, press at the far ends of the LED Reflector edge softly. Otherwise the TFT Module may be damaged.
- 10) At the insertion or removal of the Signal Interface Connector, be sure not to rotate nor tilt the Interface Connector of the TFT Module.
- 11) TFT-LCD Module is not allowed to be twisted & bent even force is added on module in a very short time. Please design your display product well to avoid external force applying to module by end-user directly.
- 12) Small amount of materials without flammability grade are used in the TFT-LCD module. The TFT-LCD module should be supplied by power complied with requirements of Limited Power Source (IEC60950-1 or UL60950-1), or be applied exemption.
- 13) Severe temperature condition may result in different luminance, response time.
- 14) Continuous operating TFT-LCD Module under high temperature environment may accelerate LED light bar exhaustion and reduce luminance dramatically.
- 15) The data on this specification sheet is applicable when TFT-LCD module is placed in landscape position.
- 16) Continuous displaying fixed pattern may induce image sticking. It's recommended to use screen saver or moving content periodically if fixed pattern is displayed on the screen.



2. General Description

G150XTN05.1 is a Color Active Matrix Liquid Crystal Display composed of a TFT-LCD display, a driver circuit, and a backlight system. The screen format is intended to support XGA (1024(H) x 768(V)) screen and 16.2M (RGB 8-bits) or 262k colors (RGB 6-bits). All input signals are LVDS interface compatible.

G150XTN05.1 is designed for industrial display applications.

2.1 Display Characteristics

The following items are characteristics summary on the table under 25 °C condition:

Items	Unit	Specifications
Screen Diagonal	[inch]	15
Active Area	[mm]	304.128(H) x 228.096(V)
Pixels H x V		1024x3(RGB) x 768
Pixel Pitch	[mm]	0.297 x 0.297
Pixel Arrangement		R.G.B. Vertical Stripe
Display Mode		TN, Normally White
Nominal Input Voltage VDD	[Volt]	3.3 typ.
Typical Power Consumption	[Watt]	37 (TBD)
Weight	[Grams]	TBD
Physical Size	[mm]	326.5(H)x 253.5(V) x 14.3(D)
Electrical Interface		1 channel LVDS
Surface Treatment		Anti-glare
Support Color		16.2M / 262K colors
Temperature Range Operating Storage (Non-Operating)	[°C] [°C]	-30 to +85 -30 to +85
RoHS Compliance		RoHS Compliance
Light Bar Unit		LED, Replaceable



2.2 Optical Characteristics

The optical characteristics are measured under stable conditions at 25°C (Room Temperature):

Item	Unit	Conditions	Min.	Typ.	Max.	Note
White Luminance	[cd/m ²]		960	1200	-	1
Uniformity	%	9 Points	75	80	-	1, 2, 3
Contrast Ratio				700	-	4
Cross talk	%		-	1.2	1.5	5
Response Time	[msec]	Rising	-	5.7		6
	[msec]	Falling	-	2.3		
	[msec]	Raising + Falling	-	8		
Viewing Angle	[degree]	Horizontal (Right) CR = 10 (Left)	60	70	-	7
	[degree]		60	70	-	
	[degree]	Vertical (Upper) CR = 10 (Lower)	50	60	-	
Color / Chromaticity Coordinates (CIE 1931)		Red x		TBD		
		Red y		TBD		
		Green x		TBD		
		Green y		TBD		
		Blue x		TBD		
		Blue y		TBD		
		White x	0.263	0.313	0.363	
White y	0.279	0.329	0.379			
Color Gamut	%			65	-	

Note 1: Measurement method

Equipment Pattern Generator, Power Supply, Digital Voltmeter, Luminance meter (SR_3 or equivalent)

Aperture 1° with 50cm viewing distance

Test Point Center

Environment < 1 lux

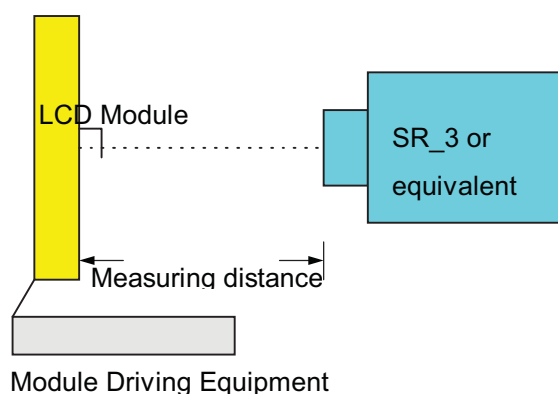



Note 2: Definition of 9 points position (Display active area : 304.128(H) x 228.096(V))

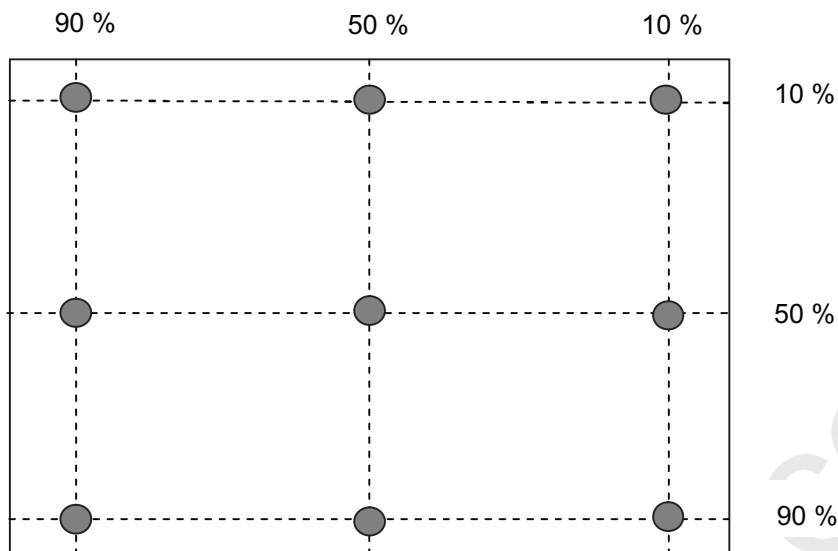

Note 3: The luminance uniformity of 9 points is defined by dividing the minimum luminance values by the maximum test point luminance

$$\delta_{w9} = \frac{\text{Minimum Brightness of nine points}}{\text{Maximum Brightness of nine points}}$$

Note 4 : Definition of contrast ratio (CR):

$$\text{Contrast ratio (CR)} = \frac{\text{Brightness on the "White" state}}{\text{Brightness on the "Black" state}}$$

Note 5 : Definition of cross talk (CT)

$$CT = |YB - YA| / YA \times 100 (\%)$$

Where

YA = Luminance of measured location without gray level 0 pattern (cd/m²)

YB = Luminance of measured location with gray level 0 pattern (cd/m²)

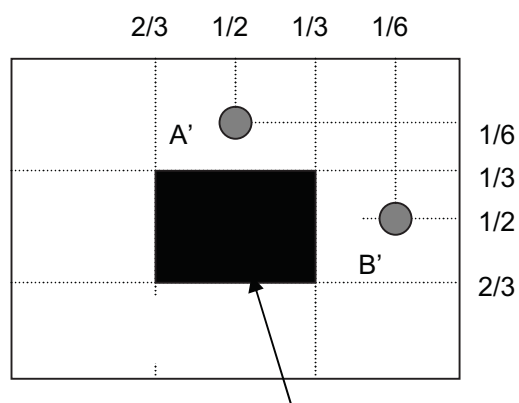
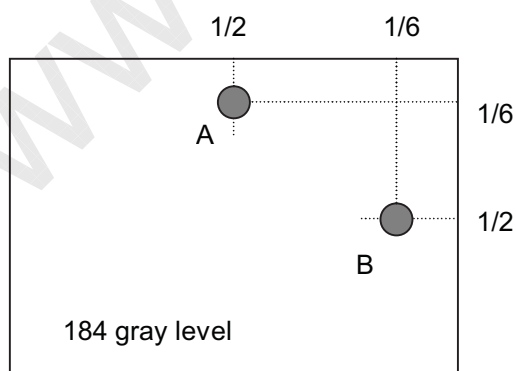



Note 6: Definition of response time:

The output signals of photo detector are measured when the input signals are changed from "White" to "Black" (falling time) and from "Black" to "White" (rising time), respectively. The response time interval is between 10% and 90% of amplitudes. Please refer to the figure as below.

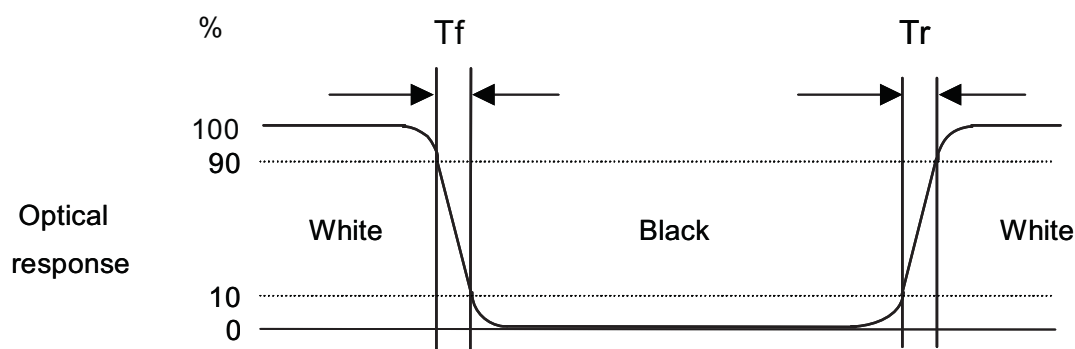

Note 7: Definition of viewing angle

Viewing angle is the measurement of contrast ratio ≥ 10 , at the screen center, over a 180° horizontal and 180° vertical range (off-normal viewing angles). The 180° viewing angle range is broken down as below: 90° (θ) horizontal left and right, and 90° (ϕ) vertical high (up) and low (down). The measurement direction is typically perpendicular to the display surface with the screen rotated to its center to develop the desired measurement viewing angle.

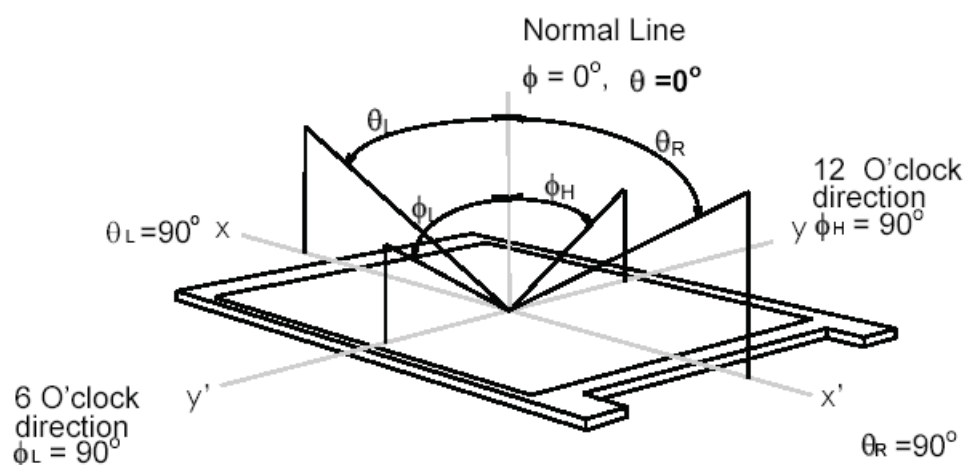



3. Functional Block Diagram

The following diagram shows the functional block of the 15 inch color TFT/LCD module:

TBD

www.panelook.com



4. Absolute Maximum Ratings

4.1 Absolute Ratings of TFT LCD Module

Item	Symbol	Min	Max	Unit
Logic/LCD Drive	Vin	-0.3	+3.6	[Volt]

4.2 Absolute Ratings of Environment

Item	Symbol	Min	Max	Unit
Operating Temperature	TOP	-30	+85	[°C]
Operation Humidity	HOP	8	90	[%RH]
Storage Temperature	TST	-30	+85	[°C]
Storage Humidity	HST	8	90	[%RH]

Note: Maximum Wet-Bulb should be 39°C and no condensation.

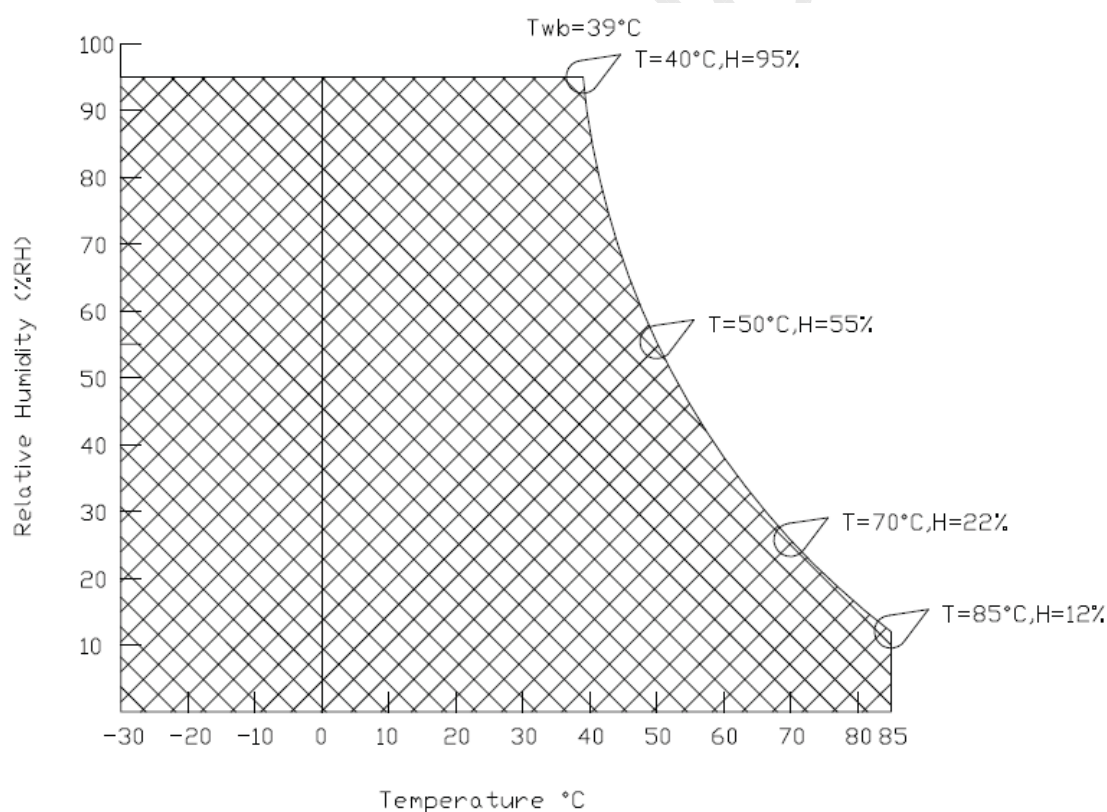



5. Electrical Characteristics

5.1 TFT LCD Module

5.1.1 Power Specification

Symbol	Parameter	Min	Typ	Max	Units	Remark
VDD	Logic/LCD Drive Voltage	3.0	3.3	3.6	[Volt]	± 10%
IDD	VDD Current	-	550	660	[mA]	64 Gray Bar Pattern (VDD=3.3V, at 60Hz)
Irush	LCD Inrush Current	-	-	TBD	[A]	Note 1
PDD	VDD Power	-	1.9	2.2	[Watt]	64 Gray Bar Pattern (VDD=3.3V, at 60Hz)

Note 1: Measurement condition:

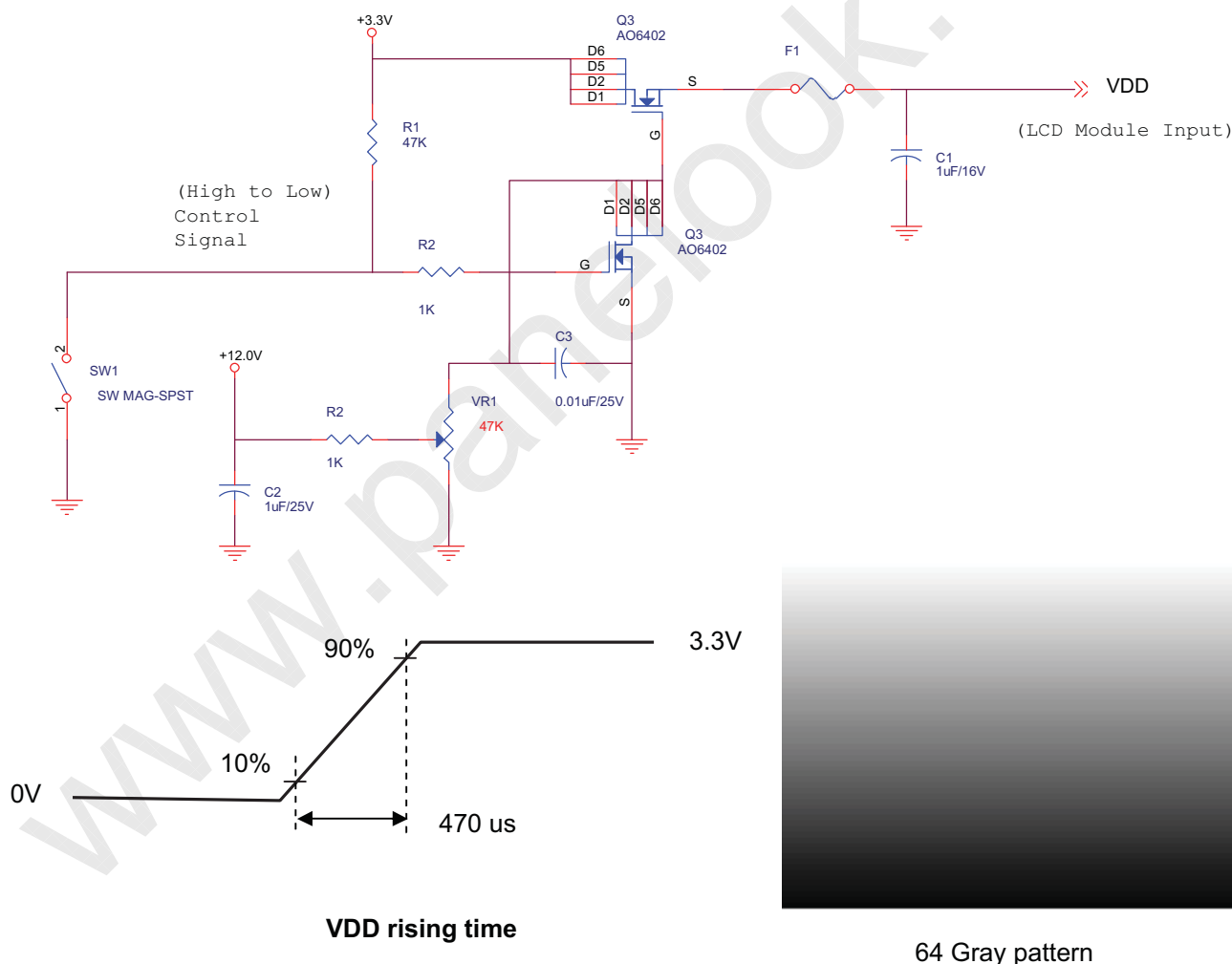



5.1.2 Signal Electrical Characteristics

Input signals shall be low or Hi-Z state when VDD is off.

Symbol	Item	Min.	Typ.	Max.	Unit	Remark
V _{TH}	Differential Input High Threshold	-	-	100	[mV]	V _{CM} =1.2V
V _{TL}	Differential Input Low Threshold	-100	-	-	[mV]	V _{CM} =1.2V
VID	Input Differential Voltage	100	400	600	[mV]	
V _{ICM}	Differential Input Common Mode Voltage	1.1		1.45	[V]	V _{TH} /V _{TL} =±100mV

Note: LVDS Signal Waveform.

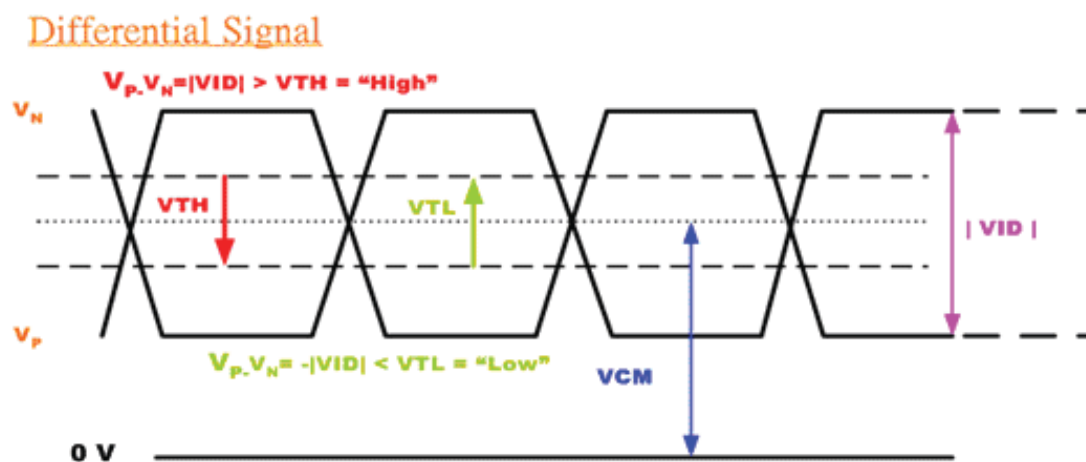



5.2 Backlight Unit

5.2.1 Parameter guideline for LED

Following characteristics are measured under stable condition using a LED driving board at 25°C (Room Temperature).

Symbol	Parameter	Min	Typ	Max	Unit	Remark
V _{cc}	Input Voltage	10.8	12	13.2	Volt	
I _{vcc}	Input Current	-	2.86	-	A	100% Dimming
P _{LED}	Power Consumption	-	34.4	-	Watt	100% Dimming
Inrush	Inrush Current	-	-	TBD	A	
V _{LED on/off}	On Control Voltage	TBD	-	TBD	Volt	
	Off Control Voltage	-	-	TBD	Volt	
F _{PWM}	PWM Dimming Frequency	140	180	1K	Hz	
	High Voltage	TBD		TBD	Volt	
	Low Voltage	-	-	TBD	Volt	
	Dimming Duty Cycle	5	-	100	%	
I _F	LED Forward Current	-	130	135	mA	Ta = 25°C
Operating Life		50000	-	-	Hrs	Ta = 25°C

Note 1: Ta means ambient temperature of TFT-LCD module.

Note 2: If G150XTN05.1 module is driven at high ambient temperature & humidity condition. The operating life will be reduced.

Note 3: Operating life means brightness goes down to 50% initial brightness. Min. operating life time is estimated data.



6. Signal Characteristic

6.1 Pixel Format Image

Following figure shows the relationship between input signal and LCD pixel format.

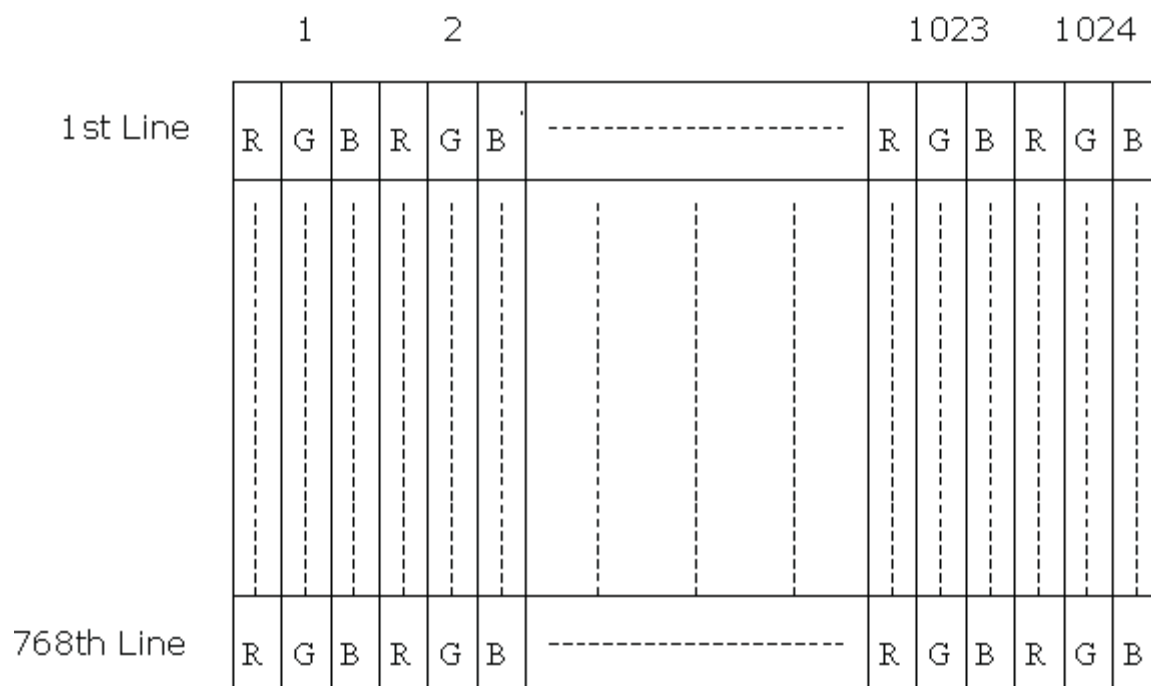

6.2 Scanning Direction

The following figures show the image seen from the front view. The arrow indicates the direction of scan.

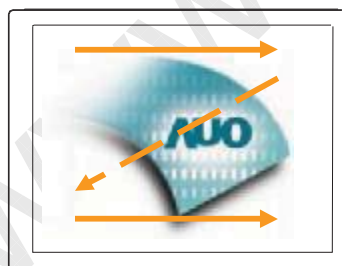

Fig. 1 Normal scan (Pin4, REV = Low or NC)

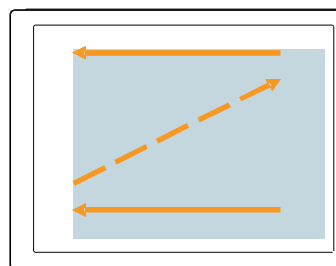

Fig. 2 Reverse scan (Pin4, REV = High)



6.3 Signal Description

The module using a pair of LVDS receiver SN75LVDS82(Texas Instruments) or compatible. LVDS is a differential signal technology for LCD interface and high speed data transfer device. Transmitter shall be SN75LVDS83(negative edge sampling) or compatible. The first LVDS port(RxOxxx) transmits odd pixels while the second LVDS port(RxExxx) transmits even pixels.

3804-F20N-06R (E&T) / MSB240420E(STM)		
Pin No.	Symbol	Description
1	VDD	Power Supply, 3.3V (typical)
2	VDD	Power Supply, 3.3V (typical)
3	VSS	Ground
4	REV	Reverse Scan selection *.Note1
5	Rin1-	- LVDS differential data input (R0-R5, G0)
6	Rin1+	+ LVDS differential data input (R0-R5, G0)
7	VSS	Ground
8	Rin2-	- LVDS differential data input (G1-G5, B0-B1)
9	Rin2+	+ LVDS differential data input (G1-G5, B0-B1)
10	VSS	Ground
11	Rin3-	- LVDS differential data input (B2-B5, HS, VS, DE)
12	Rin3+	+ LVDS differential data input (B2-B5, HS, VS, DE)
13	VSS	Ground
14	ClkIN-	- LVDS differential clock input
15	ClkIN+	+ LVDS differential clock input
16	GND	Ground
17	Rin4-	- LVDS differential data input (R6-R7, G6-G7,B6-B7) * Note2
18	Rin4+	+ LVDS differential data input (R6-R7, G6-G7,B6-B7) * Note2
19	VSS	Ground
20	SEL68	Selection for 6 bits/8bits LVDS data input * Note1,3

Note 1: Input signals shall be in low status when VDD is off.

Note 2: If only the 6 bits mode is needed, pin 17 and pin 18 are suggested to be floated. (In this situation, 8 bits mode will be disable permanently)

Note 3: High stands for "3.3V", Low stands for "GND", NC stands for "No Connection".



6.4 The Input Data Format

6.4.1 SEL68

SEL68 = "High" or "NC" for 6 bits LVDS Input

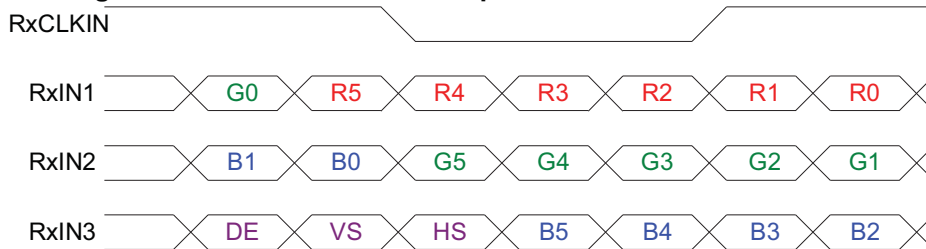

SEL68 = "Low" for 8 bits LVDS Input

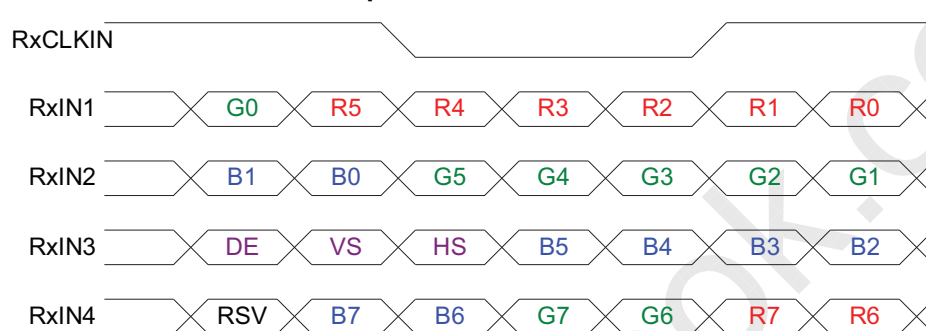

Note1: Please follow PSWG.

Note2: R/G/B data 7:MSB, R/G/B data 0:LSB

Signal Name	Description	Remark
R7	Red Data 7	Red-pixel Data
R6	Red Data 6	
R5	Red Data 5	
R4	Red Data 4	
R3	Red Data 3	
R2	Red Data 2	
R1	Red Data 1	
R0	Red Data 0	For 8Bits LVDS input MSB: R7 ; LSB: R0
G7	Green Data 7	Green-pixel Data
G6	Green Data 6	
G5	Green Data 5	
G4	Green Data 4	
G3	Green Data 3	
G2	Green Data 2	
G1	Green Data 1	
G0	Green Data 0	For 8Bits LVDS input MSB: G7 ; LSB: G0
B7	Blue Data 7	Blue-pixel Data
B6	Blue Data 6	
B5	Blue Data 5	
B4	Blue Data 4	
B3	Blue Data 3	
B2	Blue Data 2	
B1	Blue Data 1	
B0	Blue Data 0	For 8Bits LVDS input MSB: B7 ; LSB: B0
RxCLKIN	LVDS Data Clock	For 6Bits LVDS input MSB: R5 ; LSB: R0
DE	Data Enable Signal	When the signal is high, the pixel data shall be valid to be displayed.
VS	Vertical Synchronous Signal	
HS	Horizontal Synchronous Signal	

Note: Output signals from any system shall be low or Hi-Z state when VDD is off.



6.5 Interface Timing

6.5.1 Timing Characteristics

Signal	Parameter	Symbol	Min.	Typ.	Max.	Unit	
Clock Timing	Clock frequency	$1/T_{\text{Clock}}$	50	65	81	MHz	
Vsync Timing	Vertical Section	Period	T_V	776	806	900	T_{Line}
		Active	T_{VD}	768	768	768	
		Blanking	T_{VB}	8	38	132	
Hsync Timing	Horizontal Section	Period	T_H	1054	1344	2048	T_{Clock}
		Active	T_{HD}	1024	1024	1024	
		Blanking	T_{HB}	30	320	1024	
Frame Rate		F	50	60	75	Hz	

Note: DE mode only.

Note : Typical value refer to VESA STANDARD

6.5.2 Input Timing Diagram

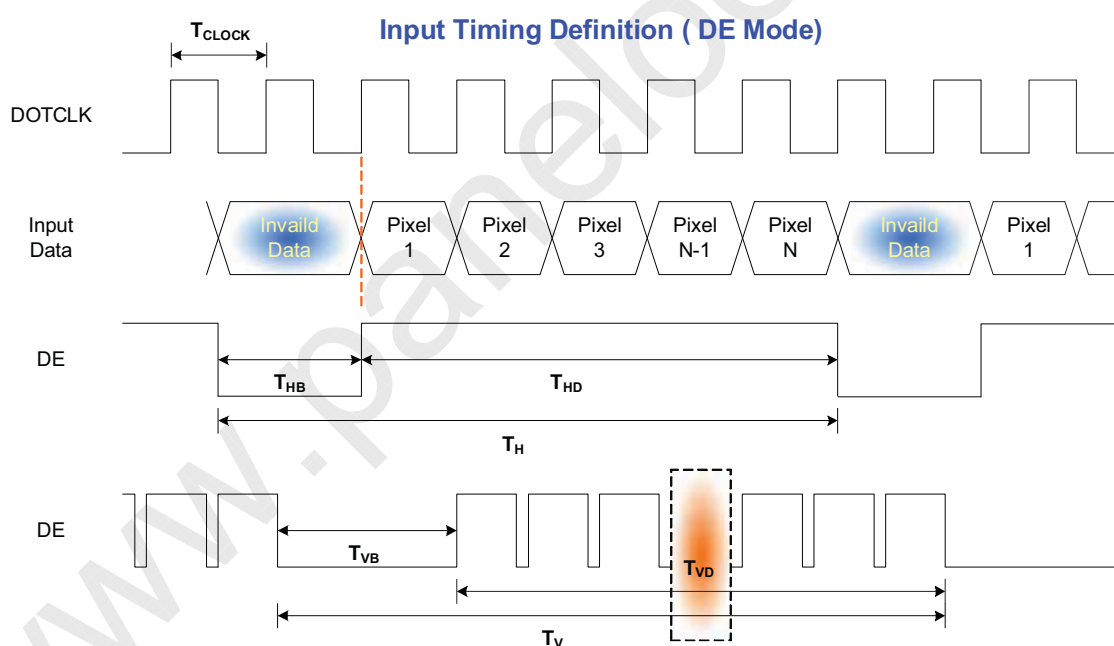



6.6 Power ON/OFF Sequence

VDD power and LED on/off sequence is as below. Interface signals are also shown in the chart. Signals from any system shall be Hi-Z state or low level when VDD is off.

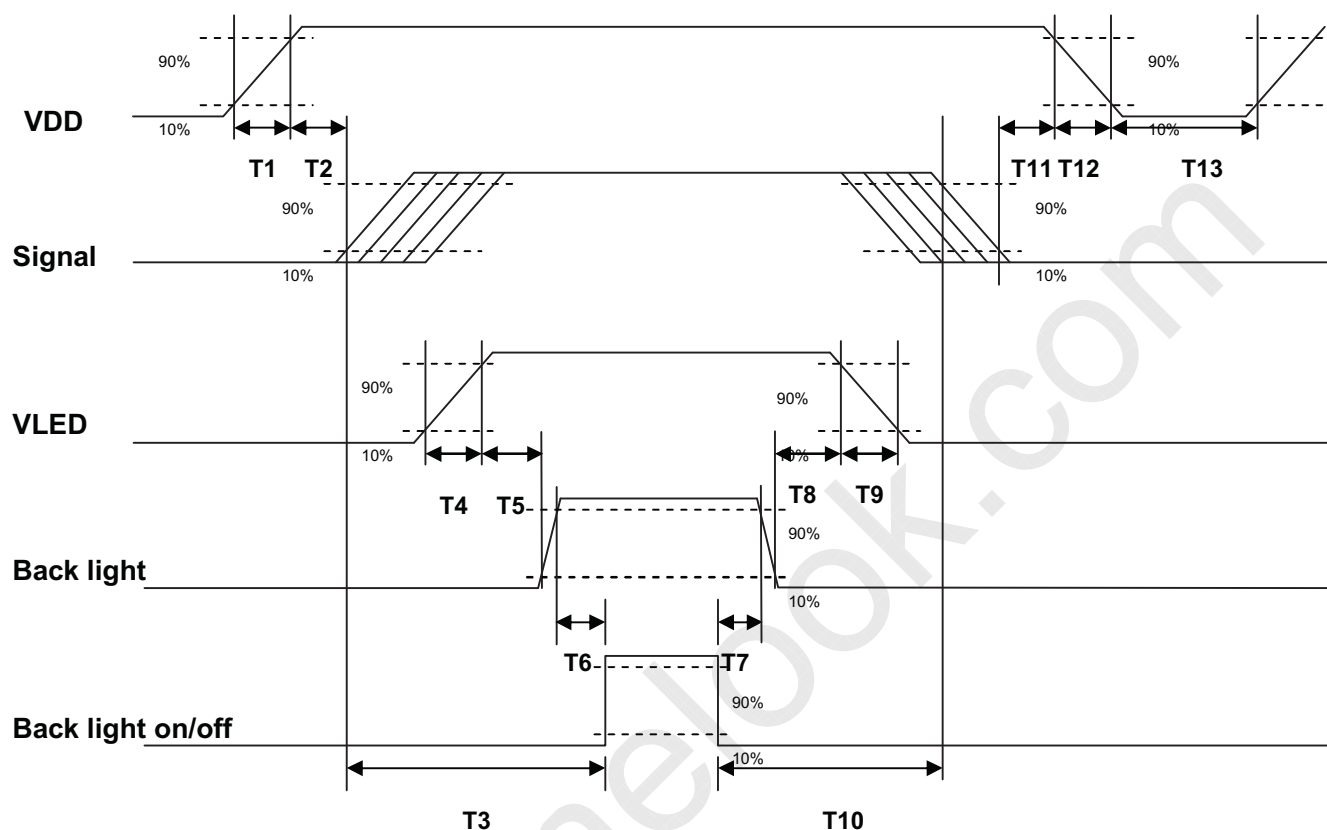

Power ON/OFF sequence timing

Parameter	Value			Units
	Min.	Typ.	Max.	
T1	0.5	--	10	[ms]
T2	30	40	50	[ms]
T3	200	--	--	[ms]
T4	0.5	--	10	[ms]
T5	10	--	--	[ms]
T6	10	--	--	[ms]
T7	0	--	--	[ms]
T8	10	--	--	[ms]
T9	--	--	10	[ms]
T10	110	--	--	[ms]
T11	0	16	50	[ms]
T12	--	--	10	[ms]
T13	1000	--	--	[ms]

The above on/off sequence should be applied to avoid abnormal function in the display. Please make sure to turn off the power when you plug the cable into the input connector or pull the cable out of the connector.



7. Connector & Pin Assignment

Physical interface is described as for the connector on module. These connectors are capable of accommodating the following signals and will be following components.

7.1 TFT LCD Module: LVDS Connector

Connector Name / Designation	Signal Connector
Manufacturer	E&T or compatible
Connector Model Number	3804-F20N-06R / MSB240420E
Adaptable Plug	HRS DF14-20S-1.25C

Pin#	Signal Name	Pin#	Signal Name
1	VDD	2	VDD
3	VSS	4	REV
5	Rin1-	6	Rin1+
7	VSS	8	Rin2-
9	Rin2+	10	VSS
11	Rin3-	12	Rin3+
13	VSS	14	ClkIN-
15	ClkIN+	16	GND
17	Rin4-	18	Rin4+
19	VSS	20	SEL68



7.1.1 Connector Illustration

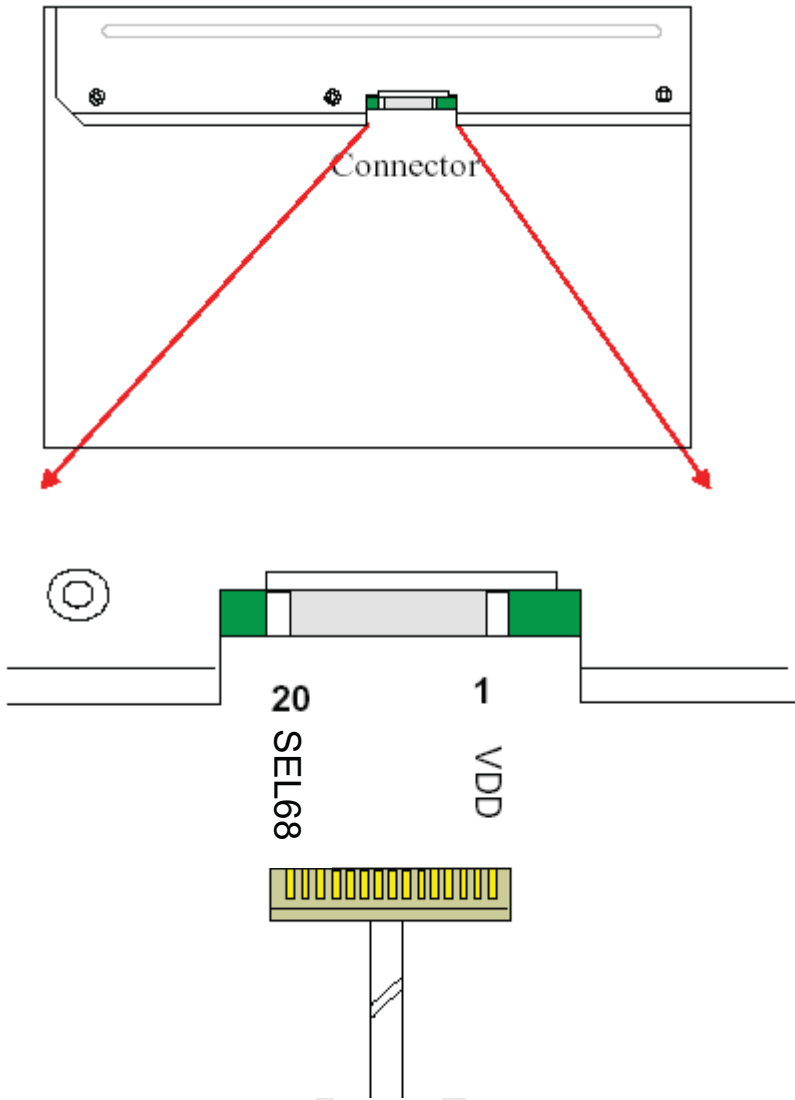



7.2 Backlight Unit: LED Driver Board Connector

Connector Name / Designation	LED Driver Board Connector
Manufacturer	ENTERY or compatible
Connector Model Number	3806K-X12X-03X (TBD) or compatible
Mating Model Number	H208K-P12N-02 B (TBD) or compatible

7.3 LED Driver Board Connector Pin Assignment

Pin#	Symbol	Signal Name
1	VDDB	12V
2	VDDB	12V
3	VDDB	12V
4	VDDB	12V
5	BLGND	GND
6	BLGND	GND
7	BLGND	GND
8	BLGND	GND
9	NC	NC
10	DET ⁽¹⁾	Normal: GND ; Abnormal: Open collector
11	VBLON	2.0~5.5V-ON / 0V-OFF
12	Dimming	PWM Dimming

Note (1) DET is detect function. When backlight is normal operating, DET is GND(0V). when backlight is abnormal, DET is Open Collector.



7.4 Backlight Unit: LED Connector

Connector Name / Designation	LED Connector
Manufacturer	ENTERY or compatible
Connector Model Number	3806K-X6X-03X (TBD) or compatible
Mating Model Number	H208K-P6N-02 B (TBD) or compatible

7.5 LED Connector Pin Assignment

Pin#	Symbol	Signal Name
1	#1 Anode	Anode of LED light bar #1
2	NC	NC
3	#1-1 Cathode	Cathode of LED light bar #1
4	#1-2 Cathode	Cathode of LED light bar #1
5	#1-3 Cathode	Cathode of LED light bar #1
6	#1-4 Cathode	Cathode of LED light bar #1

Pin#	Symbol	Signal Name
1	#2 Anode	Anode of LED light bar #2
2	NC	NC
3	#2-1 Cathode	Cathode of LED light bar #2
4	#2-2 Cathode	Cathode of LED light bar #2
5	#2-3 Cathode	Cathode of LED light bar #2
6	#2-4 Cathode	Cathode of LED light bar #2



8. Reliability Test Criteria

Items	Required Condition	Note
Temperature Humidity Bias	50°C/80%,300 hours	
High Temperature Operation	85°C,300 hours	
Low Temperature Operation	-30°C,300 hours	
Hot Storage	85°C,300 hours	
Cold Storage	-30°C,300 hours	
Thermal Shock Test	-20°C/30 min ,60°C/30 min ,100cycles	
Shock Test (Non-Operating)	50G,20ms,Half-sine wave,(±X, ±Y, ±Z)	
Vibration Test (Non-Operating)	1.5G, (10~200Hz, P-P) 30 mins/axis (X, Y, Z)	
On/off test	On/10 sec, Off/10 sec, 30,000 cycles	
ESD	Contact Discharge: ± 8KV, 150pF(330Ω) 1sec, 8 points, 25 times/ point Air Discharge: ± 15KV, 150pF(330Ω) 1sec, 8 points, 25 times/ point	Note 1

Note1: According to EN61000-4-2, ESD class B: Some performance degradation allowed. No data lost
. Self-recoverable. No hardware failures.

Note 2:

- Water condensation is not allowed for each test items.
- Each test is done by new TFT-LCD module. Don't use the same TFT-LCD module repeatedly for reliability test.
- The reliability test is performed only to examine the TFT-LCD module capability.
- To inspect TFT-LCD module after reliability test, please store it at room temperature and room humidity for 24 hours at least in advance.
- No function failure occurs.



G150XTN05.1

9. Mechanical Characteristics

9.1 LCM Outline Dimension (Front View)

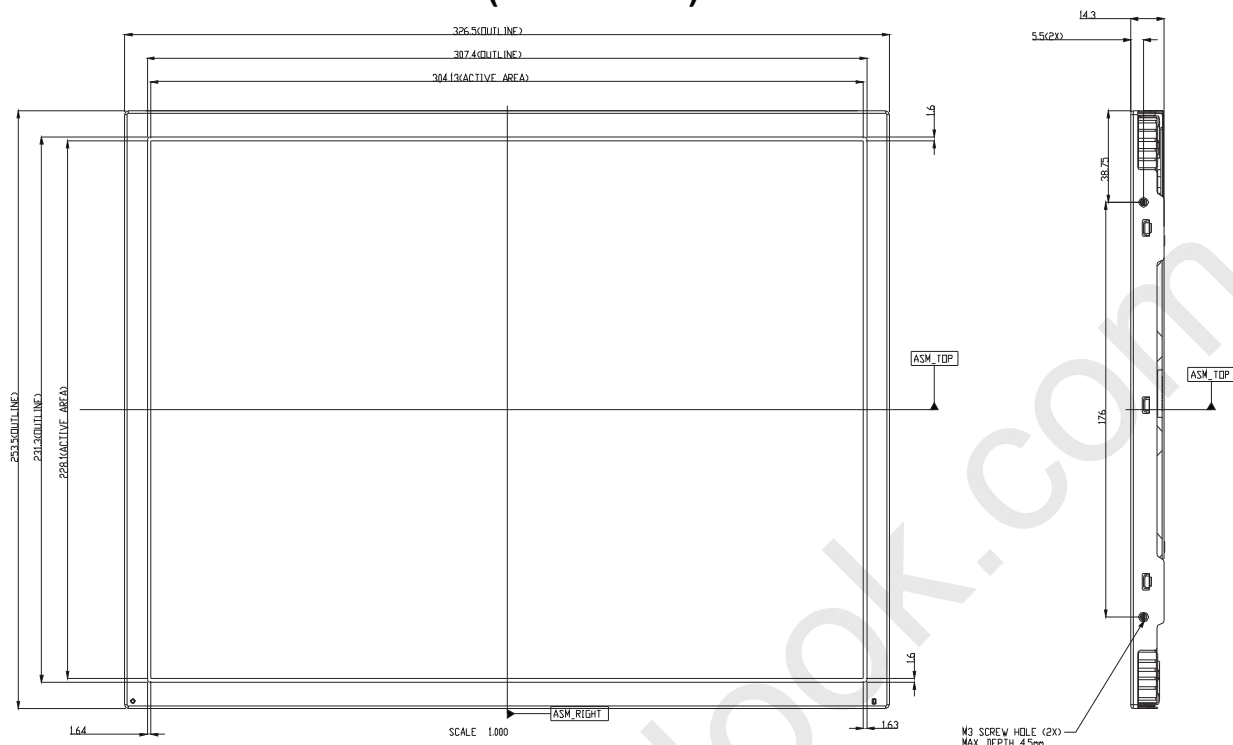

9.2 LCM Outline Dimension (Rear View)

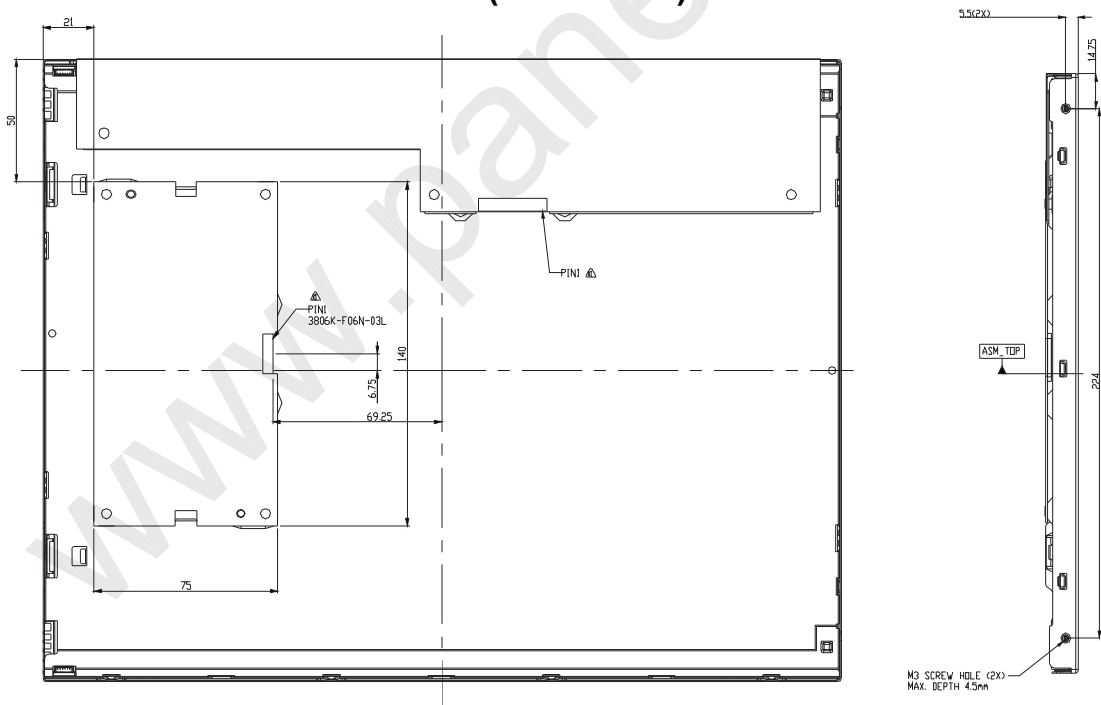

G150XTN05.1 rev. 0.0

24/26



G150XTN05.1

10. Label and Packaging

10.1 Shipping Label (on the rear side of TFT-LCD display)

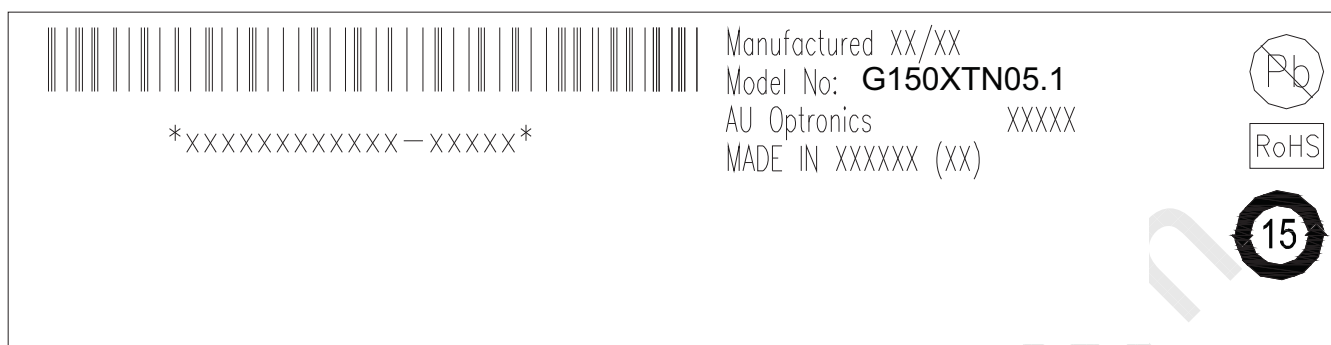

10.2 Carton Package

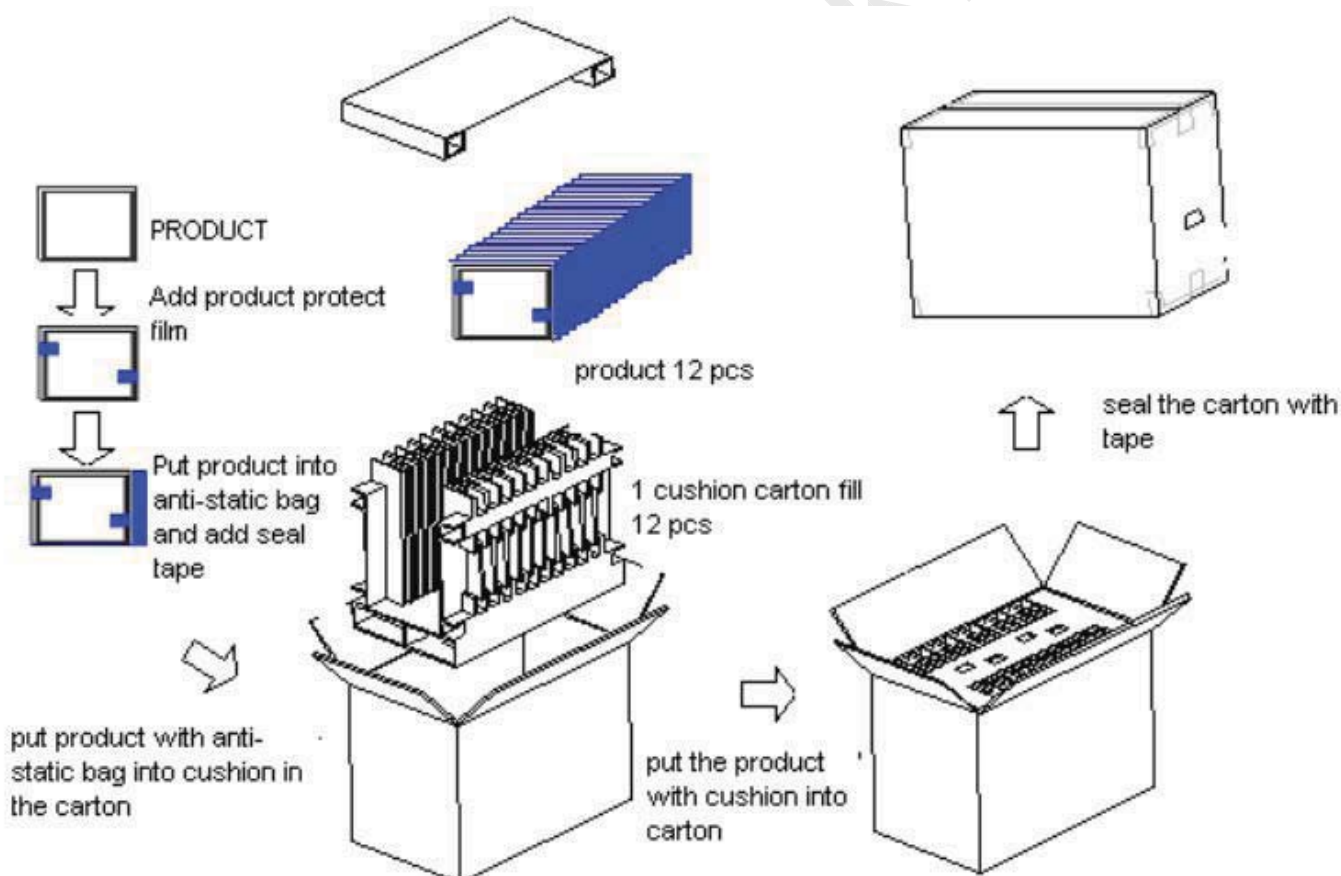

Carton capacity: 12 pcs

Carton weight: 12.56Kg

Carton outline: 430mm*384mm*350mm



11 Safety

11.1 Sharp Edge Requirements

There will be no sharp edges or comers on the display assembly that could cause injury.

11.2 Materials

11.2.1 Toxicity

There will be no carcinogenic materials used anywhere in the display module. If toxic materials are used, they will be reviewed and approved by the responsible AUO toxicologist.

11.2.2 Flammability

All components including electrical components that do not meet the flammability grade UL94-V1 in the module will complete the flammability rating exception approval process.

The printed circuit board will be made from material rated 94-V1 or better. The actual UL flammability rating will be printed on the printed circuit board.

11.3 Capacitors

If any polarized capacitors are used in the display assembly, provisions will be made to keep them from being inserted backwards.

11.4 National Test Lab Requirement

The display module will satisfy all requirements for compliance to: