



G057VTN01.0

 Preliminary Specification

 Final Specification

Module	5.7 Inch Color TFT-LCD
Model Name	G057VTN01.0

Customer	Date
_____	_____
Checked & Approved by	
_____	_____
Note: This Specification is subject to change without notice.	

Approved by	Date
<u>Leader Feng</u>	<u>2012/03/05</u>
Prepared by	
<u>Shiyen Cheng</u>	<u>2012/03/01</u>
General Display Business Division / AU Optronics corporation	



Contents

1. Operating Precautions	4
2. General Description	5
2.1 Display Characteristics.....	5
2.2 Optical Characteristics.....	6
3. Functional Block Diagram	8
4. Absolute Maximum Ratings	9
4.1 Absolute Ratings.....	9
4.2 Absolute Ratings of Environment.....	9
5. Electrical Characteristics	10
5.1 TFT-LCD Driving.....	10
5.2 Backlight Unit Driving.....	11
6. Signal Characteristic	12
6.1 Pixel Format Image.....	12
6.2 Scanning Direction.....	12
6.3 The Input Data Format.....	13
6.4 TFT- LCD Interface Signal Description.....	14
6.5 TFT- LCD Interface Timing.....	15
6.6 LED Backlight Unit Interface Signal Description.....	16
6.7 Power ON/OFF Sequence.....	16
7. Connector & Pin Assignment	17
7.1 TFT- LCD Signal (CN1): LCD Connector.....	17
7.2 LED Backlight Unit (CN2): Backlight Connector.....	17
7.3 LED Light Bar Input (CN3): Light Bar Connector.....	18
7.4 PIN 1 definition of CN1 and CN2.....	19
8. Reliability Test Criteria	20
9. Mechanical Characteristics	21
10. Label and Packaging	22
10.1 Shipping Label (on the rear side of TFT-LCD display).....	22
10.2 Carton Package.....	22
11 Safety	23
11.1 Keen Edge Requirements.....	23
11.2 Materials.....	23
11.3 Capacitors.....	23
11.4 National Test Lab Requirement.....	23



G057VTN01.0

Record of Revision

Version and Date	Page	Old description	New Description	Remark
V 0.1 Mar, 01, 2012	All	Copied from G057VN01 V2	First edition preliminary specifications	
V 1.0 Final Spec Oct 17, 2012	6 17.18		<ol style="list-style-type: none"> 1. Color/Chromaticity Coordinates defined 2. Connector model updated 	



1. Operating Precautions

- 1) Display area (Polarizer) of TFT-LCD Module is easily to be damaged, please be cautious and not to scratch it.
- 2) Be sure to power off your machine before connecting or disconnecting your signal cable to TFT-LCD Module.
- 3) Wipe off water drop on display area immediately. Long contact with water may cause discoloration or spots.
- 4) When the panel surface is soiled, wipe it with absorbent cotton or soft cloth.
- 5) Display area (Glass) of TFT-LCD Module may be broken or cracked if bump Module against hard object.
- 6) To avoid ESD (Electro Static Discharge) damage, be sure to ground yourself before handling TFT-LCD Module.
- 7) Do not open nor modify the TFT-LCD module assembly.
- 8) Do not press the reflector sheet at the back of the module to any direction.
- 9) In case if TFT-LCD module has to be put back into the packing container slot after it was taken out from the container, do not press the center of the LED Reflector edge. Instead, press at the far ends of the LED Reflector edge softly. Otherwise the TFT-LCD Module may be damaged.
- 10) When inserting or removing of your signal cable to TFT-LCD Module, be sure not to apply abnormal force (rotate, tilt... etc.) to the Connector of the TFT-LCD Module.
- 11) TFT-LCD Module is not allowed to be twisted & bent even force is added on module in a very short time. Please design your display product well to avoid external force applying to module by end-user directly.
- 12) Small amount of materials without flammability grade are used in the TFT-LCD module. The TFT-LCD module should be supplied by power complied with requirements of Limited Power Source (IEC60950 or UL1950), or be applied exemption.
- 13) Severe temperature condition may result in different luminance, response time.
- 14) Continuous operating TFT-LCD Module under high temperature environment may accelerate LED light bar exhaustion and reduce luminance dramatically.
- 15) The data on this specification sheet is applicable when TFT-LCD module is placed in landscape position.
- 16) Continuous displaying fixed pattern may induce image sticking. It's recommended to use screen saver or moving content periodically if fixed pattern is displayed on the screen.



G057VTN01.0

2. General Description

G057VTN01.0 is designed for industrial display applications with VGA (640 x RGB x 480) resolution and 262k colors (RGB 6-bits). It is composed of a TFT-LCD panel, driver ICs, control and power supply circuits board and backlight unit including LED driver circuit. G057VTN01.0 offers CMOS interface for display signal input.

2.1 Display Characteristics

The following items are G057VTN01.0 characteristics summary at 25 °C (Room Temperature).

Items	Unit	Specifications
Screen Diagonal	inch	5.7
Active Area	mm	115.2(H) x 86.4(V)
Pixels H x V		640 x 3(RGB) x 480
Pixel Pitch	mm	0.18 x 0.18
Pixel Arrangement		R.G.B. Vertical Stripe
Display Mode		TN, Normally White
Nominal Input Voltage VDD	Volt	3.3 typ.
Typical Power Consumption	Watt	3.62W (LCD:0.5W/LED BLU: 3.12W) @ All black pattern, Full Load and $V_{LED}=12V$
Weight	Grams	150g (typ.), 165g (max.)
Physical Size	mm	144.0(H)x 104.6(V) x 12.3(D) (typ.)
Electrical Interface		CMOS 6-bit Parallel RGB
Surface Treatment		Anti-Glare, Hardness 3H
Support Color		262K colors
The most suitable view angle		12 o'clock
Temperature Range		
Operating	°C	-30 to +85
Storage (Non-Operating)	°C	-30 to +85
RoHS Compliance		RoHS Compliance



2.2 Optical Characteristics

The optical characteristics are measured under stable conditions at 25°C (Room Temperature).

Item	Unit	Conditions	Min.	Typ.	Max.	Remark
White Luminance	cd/m ²	V _{LED} =12V, D _{PWM} =100% (center point)	400	530	-	Note 1
Uniformity	%	5 Points		-	1.3	Note 1, 2, 3
Contrast Ratio			500	800	-	Note 4
Response Time	msec	Rising	-	15	20	Note 5
	msec	Falling	-	10	15	
	msec	Rising + Falling	-	25	35	
Viewing Angle	degree degree	Horizontal (Right) CR = 10 (Left)	70 70	80 80	- -	Note 6
	degree degree	Vertical (Upper) CR = 10 (Lower)	60 60	70 70	- -	
Color / Chromaticity Coordinates (CIE 1931)		White x	0.263	0.313	0.363	
		White y	0.279	0.329	0.379	
		Red x	0.491	0.541	0.591	
		Red y	0.263	0.313	0.363	
		Green x	0.277	0.327	0.377	
		Green y	0.549	0.599	0.649	
		Blue x	0.108	0.158	0.208	
		Blue y	0.075	0.125	0.175	
Color Gamut	%		-	50	-	

Note 1: Measurement method

Equipment Pattern Generator, Power Supply, Digital Voltmeter, Luminance meter (SR_3 or equivalent)

Aperture 1□ with 50cm viewing distance

Test Point Center

Environment < 1 lux

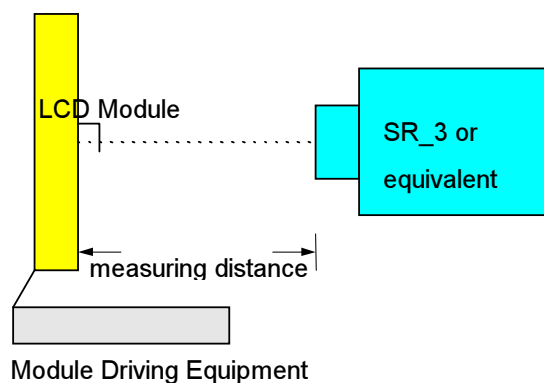



G057VTN01.0

Note 2: Definition of 5 points position (Display active area: 115.2mm(W) x 86.4mm(H))

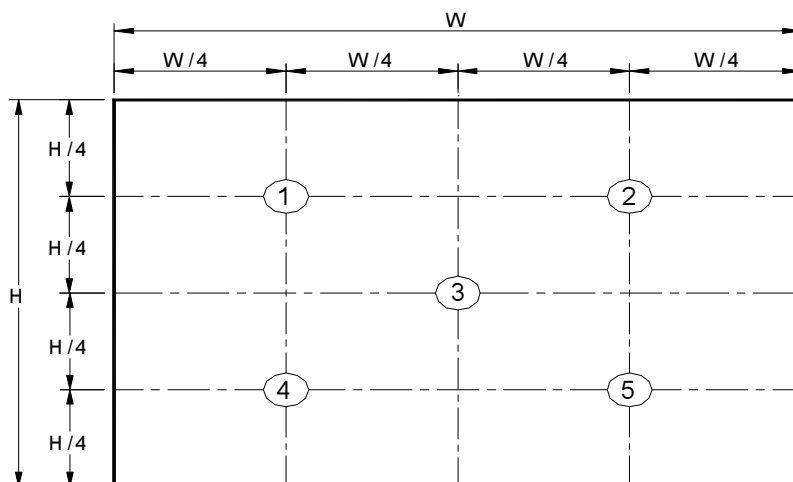

Note 3:

The luminance uniformity of 5 points is defined by dividing the maximum luminance value by the minimum luminance value at full white condition.

$$\delta_{W5} = \frac{\text{Maximum Brightness of five points}}{\text{Minimum Brightness of five points}}$$

Note 4: Definition of contrast ratio (CR):

$$\text{Contrast ratio (CR)} = \frac{\text{Brightness @ "White" state}}{\text{Brightness @ "Black" state}}$$

Note 5: Definition of response time:

The output signals of photo detector are measured when the input signals are changed from "White" to "Black" (falling time) and from "Black" to "White" (rising time), respectively. The response time interval definition is between 10% and 90% of amplitude. Please refer to the figure as below.

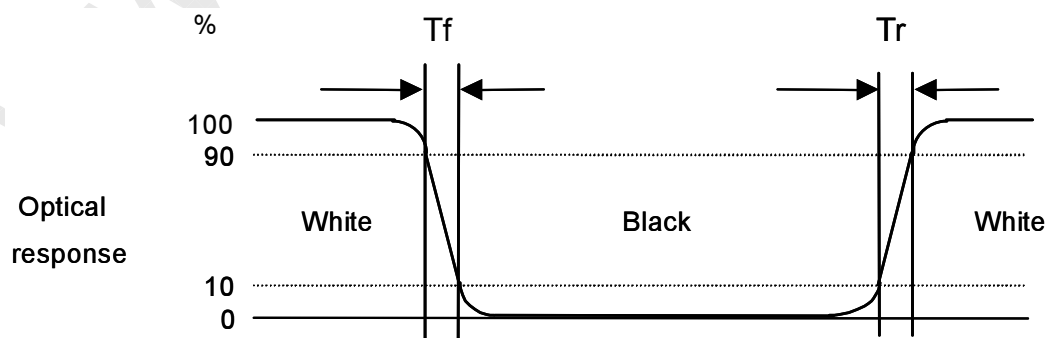

G057VTN01.0 Ver. 1.0

7/23

Note 6: Definition of viewing angle

Viewing angle is the measurement of contrast ratio ≥ 10 , at the screen center, over 180° horizontal and 180° vertical range. The 180° horizontal (θ_L, θ_R) and 180° vertical (ϕ_H, ϕ_L) range are illustrated as following figure.

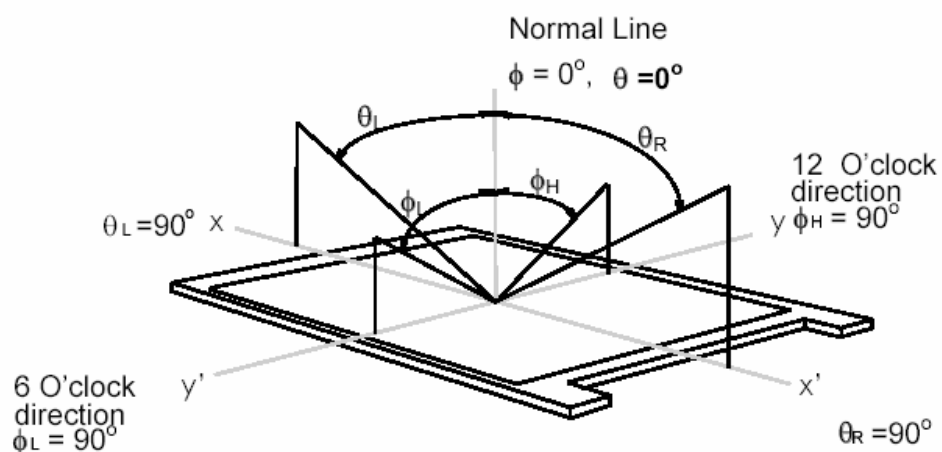

3. Functional Block Diagram

The following diagram shows the functional block of the G057VTN01.0 color TFT/LCD module.

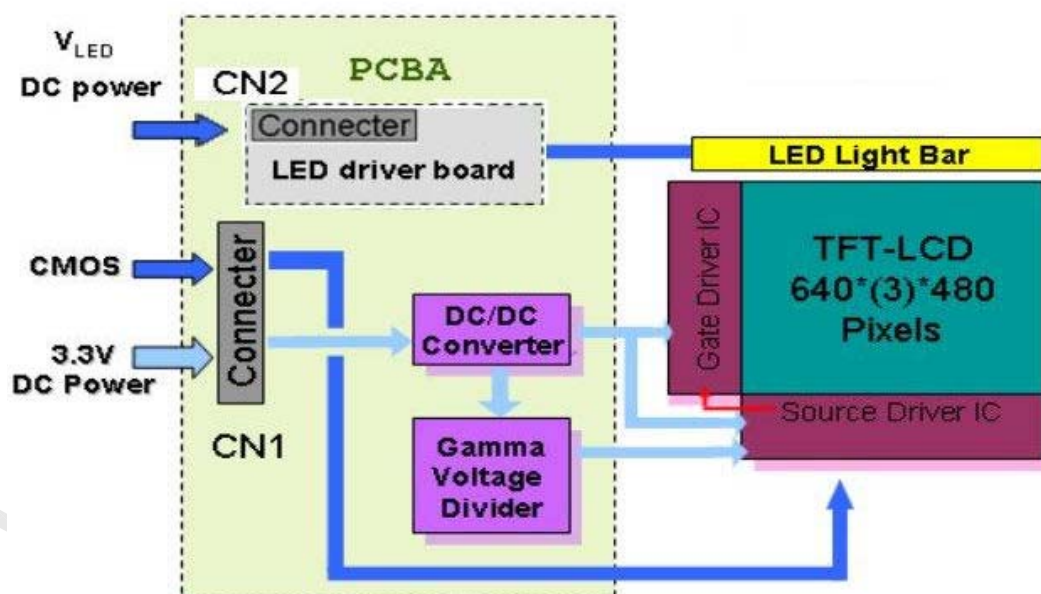



4. Absolute Maximum Ratings

4.1 Absolute Ratings

Item	Symbol	Min	Max	Unit	Remark
Logic/LCD Drive Voltage	VDD	- 0.3	+ 5.0	Volt	Ta= 25°C
LCD Input Signal Voltage	VIN	- 0.3	+ 5.0	Volt	Ta= 25°C
LED BLU Drive Voltage	V _{LED}	0	23	Volt	Ta= 25°C
LED On/Off Control Voltage	V _{LED On/Off}	0	20	Volt	Ta= 25°C
LED Dimming Input Voltage	V _{PWM}	0	8	Volt	Ta= 25°C

4.2 Absolute Ratings of Environment

Item	Symbol	Min	Max	Unit	Remark
Operating Temperature	TOP	-30	+85	°C	Note 1, 2
Operation Humidity	HOP	5	95	%RH	Note 1, 2
Storage Temperature	TST	-30	+85	°C	Note 1
Storage Humidity	HST	5	95	%RH	Note 1

Note 1: Maximum Wet-Bulb should be 39□ and no condensation.

Note 2: Only operation is guaranteed. Optical performance should be evaluated at 25□ only.



5. Electrical Characteristics

5.1 TFT-LCD Driving

5.1.1 Power Specification

Symbol	Parameter	Min	Typ	Max	Units	Remark
VDD	Logic/LCD Drive Voltage	3.0	3.3	3.6	Volt	
IDD	VDD Current	-	150	165	mA	All Black Pattern (VDD=3.3V, at 60Hz)
PDD	VDD Power	-	0.5	0.55	Watt	All Black Pattern (VDD=3.3V, at 60Hz)
VDDrp	Allowable Logic/LCD Drive Ripple Voltage	-	-	100	mVp-p	All Black Pattern (VDD=3.3V, at 60Hz)

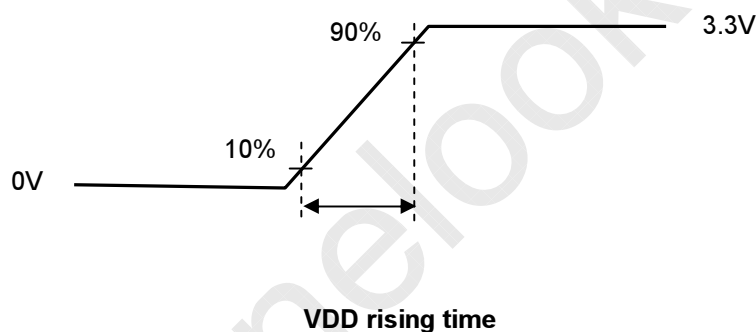

5.1.2 Signal Electrical Characteristics

Input signals shall be low or Hi-Z state when VDD is off.

Parameter	Symbol	Min.	Typ.	Max.	Unit	Remarks
Logic Input Voltage for Display Signals	High	V_{IH}	0.7VDD	-	VDD	Volt
	Low	V_{IL}	0	-	0.3VDD	Volt
Input Voltage for RL/UD	High	V_{IH}	0.7VDD	-	VDD	Volt
	Low	V_{IL}	0	-	0.3VDD	Volt



5.2 Backlight Unit Driving

5.2.1 Parameter guideline for LED

Following characteristics are measured under stable condition using a LED driving board at 25°C (Room Temperature)

Symbol	Parameter	Min	Typ	Max	Units	Remark
V_{LED}	Input Voltage	9	12	20	Volt	
I_{LED}	Input Current	-	0.26		A	$V_{LED} = 12V, D_{PWM} = 100\%$
P_{LED}	Power Consumption	2.24	3.12	3.43	Watt	$V_{LED} = 12V, D_{PWM} = 100\%$
$V_{PWM\ DIM}$	Dimming control Voltage High	2.0	3.3	5.0	Volt	Note 1,2
	Dimming control Voltage Low	-	-	0.2	Volt	
F_{PWM}	Dimming Frequency	200		30K	Hz	
D_{PWM}	Dimming duty cycle	1		100	%	
$V_{LED\ On/Off}$	On Control Voltage	2	3.3	5.5	Volt	Note 3, 4
	Off Control Voltage	-	-	0.8	Volt	
I_F	LED Forward Current		26.7	28.1	mA	$T_a = 25^{\circ}C$, each string
V_F	LED Forward Voltage		36			$I_F = 26.7mA, T_a = -30^{\circ}C$
			32	40.0		$I_F = 26.7mA, T_a = 25^{\circ}C$
			28			$I_F = 26.7mA, T_a = 85^{\circ}C$
P_{LED}	LED Power		2.8	3.2	Watt	
Operating Life		50000	-	-	Hrs	Note 5, 6

Note 1: PWM dimming function can be operated by PWM signal. PWM duty cycle can adjust white Luminance.

(PWM High: ON and PWM Low: OFF)

Note 2: PWM signal can not be floating and pull-down to ground when waiting.

Note 3: Enable ($V_{LED\ On/Off}$) must be turned on late than V_{LED} and PWM Signal.

Note 4: Enable ($V_{LED\ On/Off}$) must be turned off early than V_{LED} and PWM Signal.

Note 5: If G057VTN01.0 module is driven by high current or at high ambient temperature & humidity condition. The operating life will be reduced.

Note 6: Operating life means brightness goes down to 50% initial brightness. Minimum operating life time is estimated data.

Note 7: See Section 6.6 for LED Backlight Unit Interface Signal Description



6. Signal Characteristic

6.1 Pixel Format Image

Following figure shows the relationship between input signal and LCD pixel format.

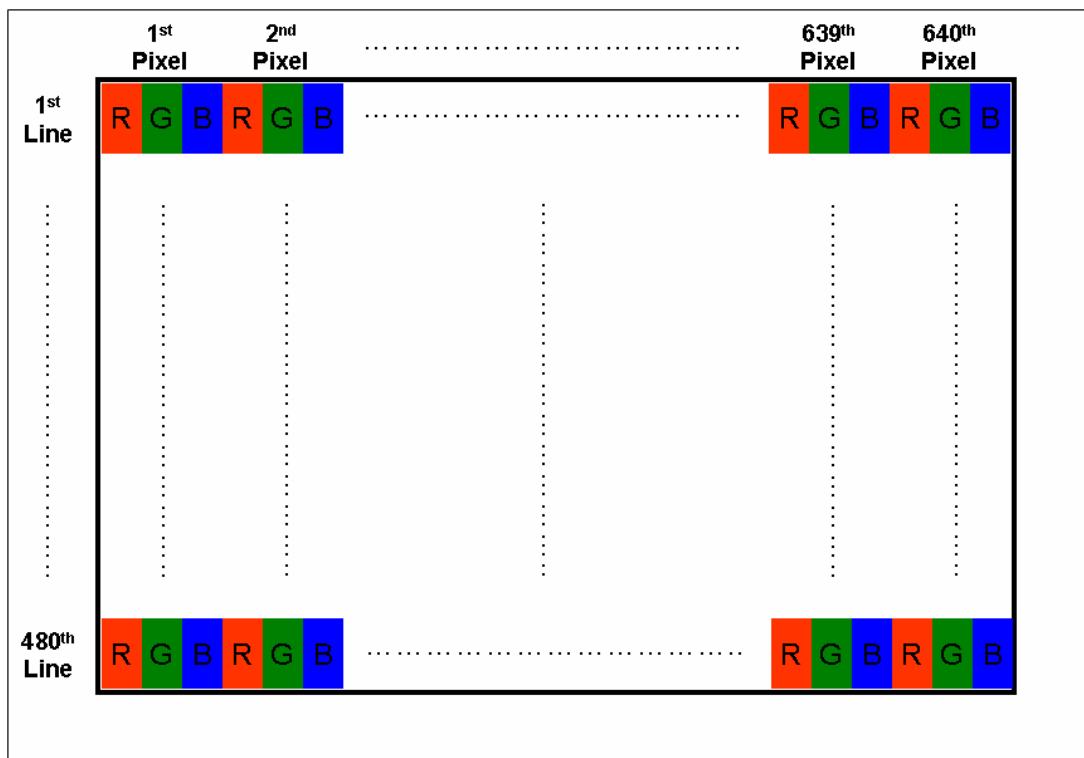

6.2 Scanning Direction

The following figures show the image seen from the front view. The arrow indicates the direction of scan.



R/L=Low or NC; U/D=High or NC



R/L=High; U/D=High or NC



R/L=Low or NC; U/D=Low



R/L=High; U/D=Low



Note 1: TFT-LCD interface signal description is shown in section 6.4.

6.3 The Input Data Format

This product displays 262,144 colors in terms of the 64 grey levels on RGB respectively. The following table demonstrates the display of input data.

Display colors		Data signal (0 : Low level, 1: High level)																	
		R5	R4	R3	R2	R1	R0	G5	G4	G3	G2	G1	G0	B5	B4	B3	B2	B1	B0
Basic colors	Black	0	0	0	0	0	0	0	0	0	0	0	0	0	0	0	0	0	0
	Blue	0	0	0	0	0	0	0	0	0	0	0	0	1	1	1	1	1	1
	Red	1	1	1	1	1	1	0	0	0	0	0	0	0	0	0	0	0	0
	Magenta	1	1	1	1	1	1	0	0	0	0	0	0	1	1	1	1	1	1
	Green	0	0	0	0	0	0	1	1	1	1	1	1	0	0	0	0	0	0
	Cyan	0	0	0	0	0	0	1	1	1	1	1	1	1	1	1	1	1	1
	Yellow	1	1	1	1	1	1	1	1	1	1	1	1	0	0	0	0	0	0
	White	1	1	1	1	1	1	1	1	1	1	1	1	1	1	1	1	1	1
Red grayscale	Black	0	0	0	0	0	0	0	0	0	0	0	0	0	0	0	0	0	0
	Dark	0	0	0	0	0	1	0	0	0	0	0	0	0	0	0	0	0	0
	↑																		
	↓																		
	bright	1	1	1	1	0	1	0	0	0	0	0	0	0	0	0	0	0	0
Green grayscale	Black	0	0	0	0	0	0	0	0	0	0	0	0	0	0	0	0	0	0
	Dark	0	0	0	0	0	0	0	0	0	1	0	0	0	0	0	0	0	0
	↑																		
	↓																		
	bright	0	0	0	0	0	0	1	1	1	1	0	1	0	0	0	0	0	0
Blue grayscale	Black	0	0	0	0	0	0	0	0	0	0	0	0	0	0	0	0	0	0
	Dark	0	0	0	0	0	0	0	0	0	0	0	0	0	0	0	0	1	0
	↑																		
	↓																		
	bright	0	0	0	0	0	0	0	0	0	0	0	0	1	1	1	1	0	1
Blue		0	0	0	0	0	0	0	0	0	0	0	1	1	1	1	1	0	
		0	0	0	0	0	0	0	0	0	0	0	1	1	1	1	1	1	
	Blue	0	0	0	0	0	0	0	0	0	0	0	1	1	1	1	1	1	1



6.4 TFT- LCD Interface Signal Description

PIN No.	Symbol	Pin Description
1	GND	Ground
2	DOTCLK	Dot clock
3	NC	NC
4	NC	NC
5	GND	Ground
6	R0	Red data (LSB)
7	R1	Red data
8	R2	Red data
9	R3	Red data
10	R4	Red data
11	R5	Red data (MSB)
12	GND	Ground
13	G0	Green data (LSB)
14	G1	Green data
15	G2	Green data
16	G3	Green data
17	G4	Green data
18	G5	Green data (MSB)
19	GND	Ground
20	B0	Blue data (LSB)
21	B1	Blue data
22	B2	Blue data
23	B3	Blue data
24	B4	Blue data
25	B5	Blue data (MSB)
26	GND	Ground
27	DE	Data Enable Signal
28	VDD	Power supply (3.3V Typ. ONLY)
29	VDD	Power supply (3.3V Typ. ONLY)
30	R/L	Horizontal reverse scan (Low or NC → Normal; High → Right & Left Reverse Scan)
31	U/D	Vertical reverse scan (High or NC → Normal, Low → Up & Down Reverse Scan)
32	NC	NC
33	GND	Ground

Note 1: "Low" stands for 0V. "High" stands for 3.3V. "NC" stands for "No Connection".



6.5 TFT- LCD Interface Timing

6.5.1 Timing Characteristics

DE mode only

Signal		Symbol	Min.	Typ.	Max.	Unit	Remark
Clock frequency (DOTCLK)		$1/T_{CLOCK}$	23.9	25.2	34.2	MHz	Note1
Data	Setup Time	Tdsu	8			ns	RL,GL,BL to DCLK
	Hold Time	Tdhd	8			ns	
DE	Setup Time	Tesu	8			ns	
Horizontal Section	Period	T_H	770	800	1000	T_{CLOCK}	Note1
	Active	T_{HD}	640				
	Blanking	T_{HB}	130	160	360		
Vertical Section	Period	T_V	516	525	570	T_{LINE}	Note1
	Active	T_{VD}	480				
	Blanking	T_{VB}	36	45	90		

Note 1: Recommended frame rate is 60 Hz.

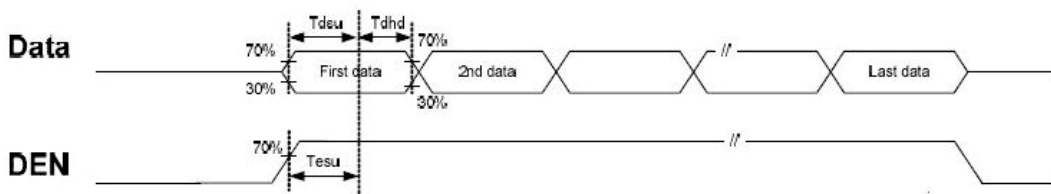

6.5.2 Input Timing Diagram

Input Timing Definition (DE Mode)

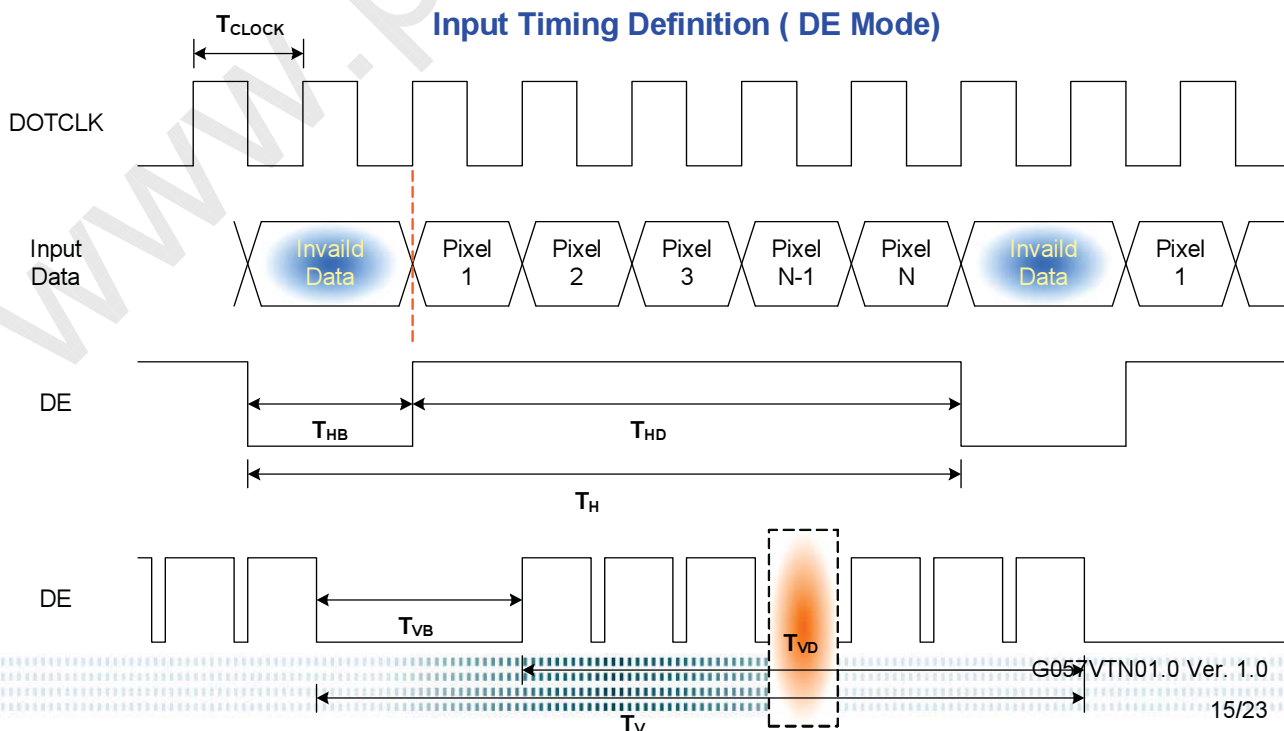



6.6 LED Backlight Unit Interface Signal Description

Pin #	Symbol	Pin Description
1	V_{LED}	12V input
2	V_{LED}	12V input
3	GND	Ground
4	GND	Ground
5	PWM DIM	1~100% PWM dimming
6	LED On/Off	0V-Off; 3.3~5V/NC-On

Note 1: "NC" stands for "No Connection"

6.7 Power ON/OFF Sequence

VDD power, LCD interface signals and backlight on/off sequence are shown in the following chart. Signals from any system shall be Hi-Z state or low level when VDD is off.

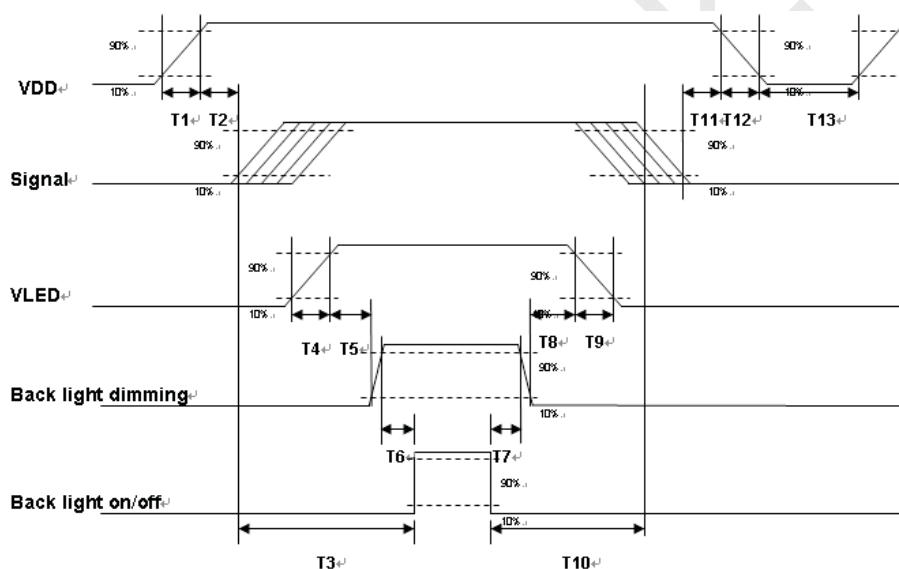

Power ON/OFF sequence timing

Parameter [Ⓢ]	Value [Ⓢ]			Unit [Ⓢ]
	Min. [Ⓢ]	Typ. [Ⓢ]	Max. [Ⓢ]	
T1 [Ⓢ]	0.5 [Ⓢ]	- [Ⓢ]	10 [Ⓢ]	[ms] [Ⓢ]
T2 [Ⓢ]	30 [Ⓢ]	40 [Ⓢ]	50 [Ⓢ]	[ms] [Ⓢ]
T3 [Ⓢ]	200 [Ⓢ]	- [Ⓢ]	- [Ⓢ]	[ms] [Ⓢ]
T4 [Ⓢ]	0.5 [Ⓢ]	- [Ⓢ]	10 [Ⓢ]	[ms] [Ⓢ]
T5 [Ⓢ]	10 [Ⓢ]	- [Ⓢ]	- [Ⓢ]	[ms] [Ⓢ]
T6 [Ⓢ]	10 [Ⓢ]	- [Ⓢ]	- [Ⓢ]	[ms] [Ⓢ]
T7 [Ⓢ]	0 [Ⓢ]	- [Ⓢ]	- [Ⓢ]	[ms] [Ⓢ]
T8 [Ⓢ]	10 [Ⓢ]	- [Ⓢ]	- [Ⓢ]	[ms] [Ⓢ]
T9 [Ⓢ]	- [Ⓢ]	- [Ⓢ]	10 [Ⓢ]	[ms] [Ⓢ]
T10 [Ⓢ]	110 [Ⓢ]	- [Ⓢ]	- [Ⓢ]	[ms] [Ⓢ]
T11 [Ⓢ]	0 [Ⓢ]	18 [Ⓢ]	50 [Ⓢ]	[ms] [Ⓢ]
T12 [Ⓢ]	- [Ⓢ]	- [Ⓢ]	10 [Ⓢ]	[ms] [Ⓢ]
T13 [Ⓢ]	1000 [Ⓢ]	- [Ⓢ]	- [Ⓢ]	[ms] [Ⓢ]

ON/OFF sequence should be applied to avoid abnormal function in the display. Please make sure to turn off the power when you plug the cable into the input connector or pull the cable out of the connector.



7. Connector & Pin Assignment

7.1 TFT- LCD Signal (CN1): LCD Connector

Manufacturer	Starconn
Connector Model Number	089H33-000100-G2-R

Pin#	Symbol	Pin#	Symbol	Pin#	Symbol
1	GND	12	GND	23	B3
2	DOTCLK	13	G0	24	B4
3	NC	14	G1	25	B5
4	NC	15	G2	26	GND
5	GND	16	G3	27	DE
6	R0	17	G4	28	VDD
7	R1	18	G5	29	VDD
8	R2	19	GND	30	R/L
9	R3	20	B0	31	U/D
10	R4	21	B1	32	NC
11	R5	22	B2	33	GND

7.2 LED Backlight Unit (CN2): Backlight Connector

Manufacturer	JST
Connector Model Number	SM06B-SRKS-G-TB (HF)
Mating Connector Model Number	JST SHR-06V-BKHF-B or compatible

Pin #	Symbol	Pin #	Symbol
1	V _{LED}	4	GND
2	V _{LED}	5	PWM DIM
3	GND	6	LED ON/OFF



7.3 LED Light Bar Input (CN3): Light Bar Connector

Manufacturer	JST
Connector Model Number	SM06B-SHLK-GTF(HF)
Mating Connector Model Number	SM06B-SHLS-TF or compatible

Pin #	Symbol	Pin Description	Cable color
1	AN1	Channel 1 LED anode	Red
2	AN2	Channel 2 LED anode	Red
3	AN3	Channel 3 LED anode	Red
4	CA1	Channel 1 LED cathode	White
5	CA2	Channel 2 LED cathode	Blue
6	CA3	Channel 3 LED cathode	Black



G057VTN01.0

7.4 PIN 1 definition of CN1、CN2 and CN3

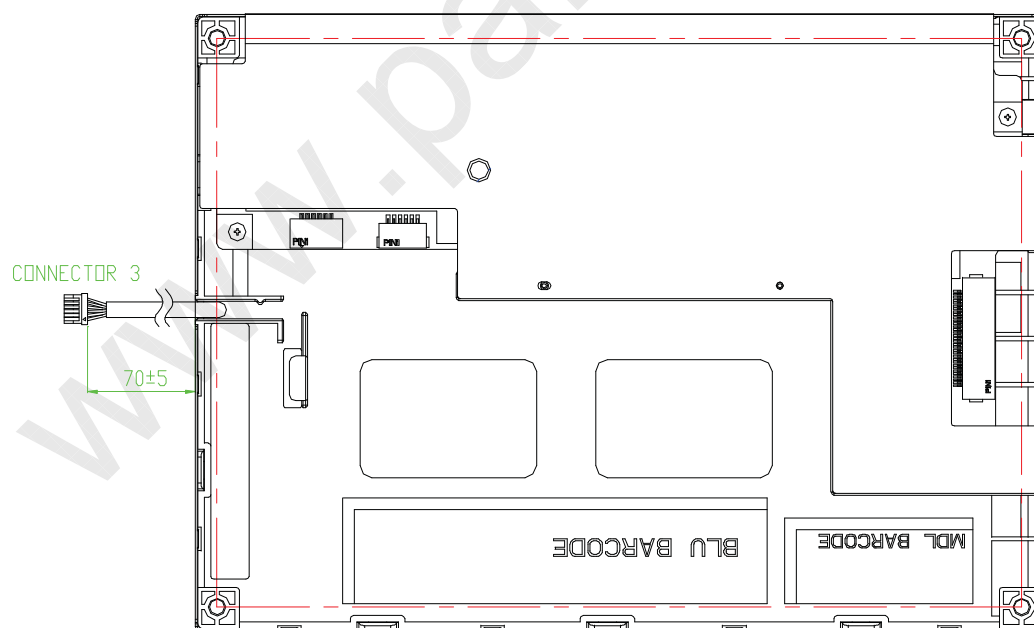
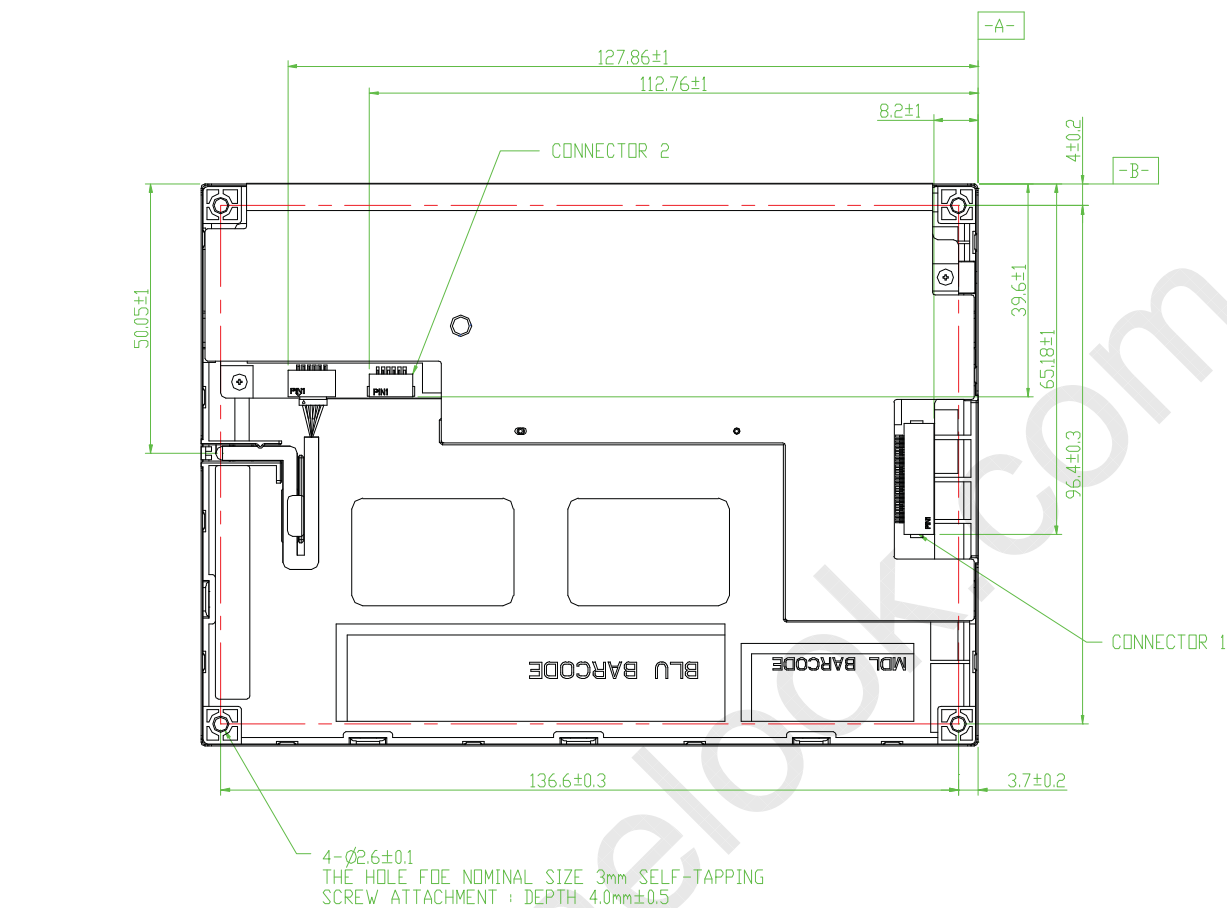

(Rear side of TFT-LCD)



8. Reliability Test Criteria

Items	Required Condition	Remark
Temperature Humidity Bias	40□/90%,300Hr	Note 2
High Temperature Operation	85□,300Hr	Note 2
Low Temperature Operation	-30□,300Hr	Note 2
High Temperature Storage	85□,300 hours	Note 2
Low Temperature Storage	-30°C,300 hours	Note 2
Thermal Shock Test	-20°C/30 min ,60°C/30 min ,100cycles	Note 2
Hot Start Test	85°C/1 Hr (min.), power on/off per 5 minutes, repeat 5 times	Note 2
Cold Start Test	-30°C/1 Hr (min.), power on/off per 5 minutes, repeat 5 times	Note 2
Shock Test (Non-Operating)	50G,20ms,Half-sine wave, (±X, ±Y, ±Z)	Note 2
Vibration Test (Non-Operating)	Sine wave : 6.8G , 10~400Hz , 280mins/axis , 0.6oct/min Random : 3.3Grms , 5-500Hz , 30mins/axis	Note 2
ESD	Contact Discharge: ±8KV, 150pF(330Ω) 1sec, 8 points, 25 times/point Air Discharge: ±15KV, 150pF(330Ω) 1sec, 8 points, 25 times/point	Note 1,2
Attitude Test	Operating: 14,000 ft, Ramp: 2000 ft/min, 8hrs Non-operating: 40,000 ft, Ramp: 2000 ft/min, 24hrs	Note 2

Note1: According to EN61000-4-2 ESD class B criteria, some performance degradation is allowed. TFT-LCD module is self-recoverable, no data lost and no hardware failures after test.

Note2:

- Water condensation is not allowed for each test items.
- Each test is done by new TFT-LCD module. Don't use the same TFT-LCD module repeatedly for reliability test.
- The reliability test is performed only to examine the TFT-LCD module capability.
- To inspect TFT-LCD module after reliability test, please store it at room temperature and room humidity for 24 hours at least in advance.



G057VTN01.0



9. Mechanical Characteristics

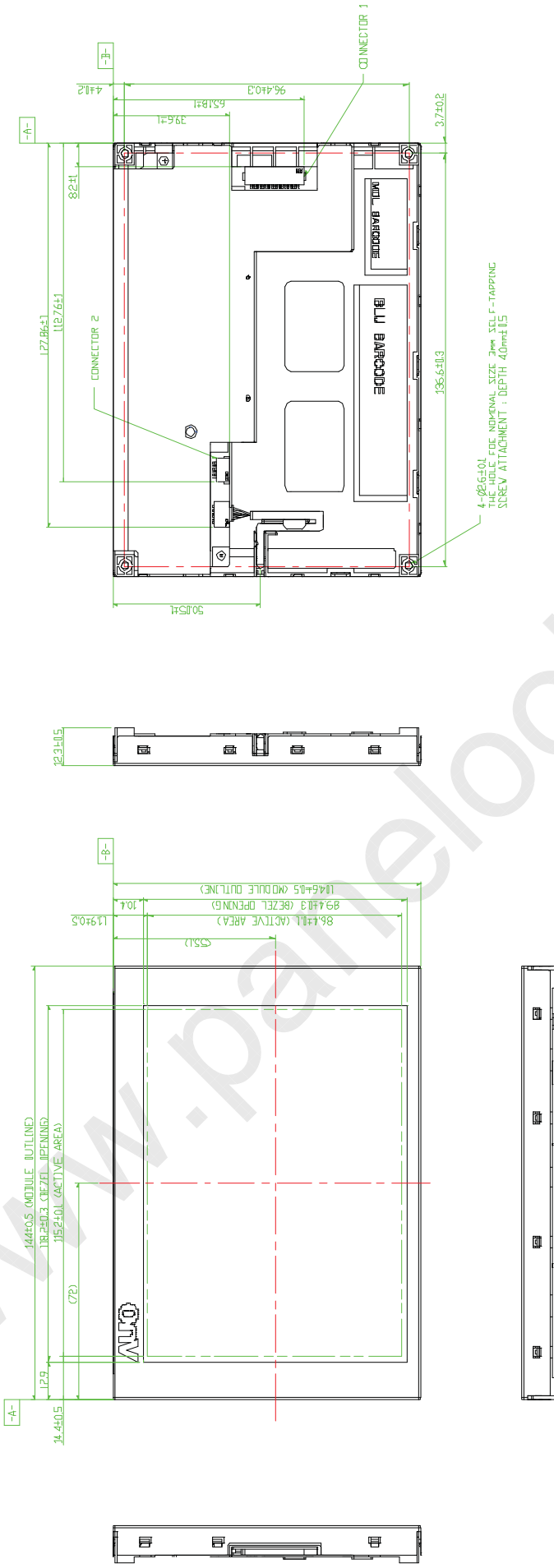

G057VTN01.0 Ver. 1.0

21/23



G057VTN01.0

10. Label and Packaging

10.1 Shipping Label (on the rear side of TFT-LCD display)

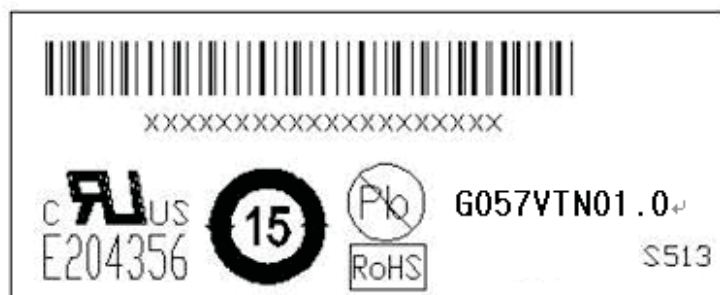

10.2 Carton Package

Max. capacity: 60 pieces TFT-LCD module per carton

Max. weight: 12.95 kg per carton

Outside dimension of carton: 520(L)mm* 340(W)mm* 250(H)mm

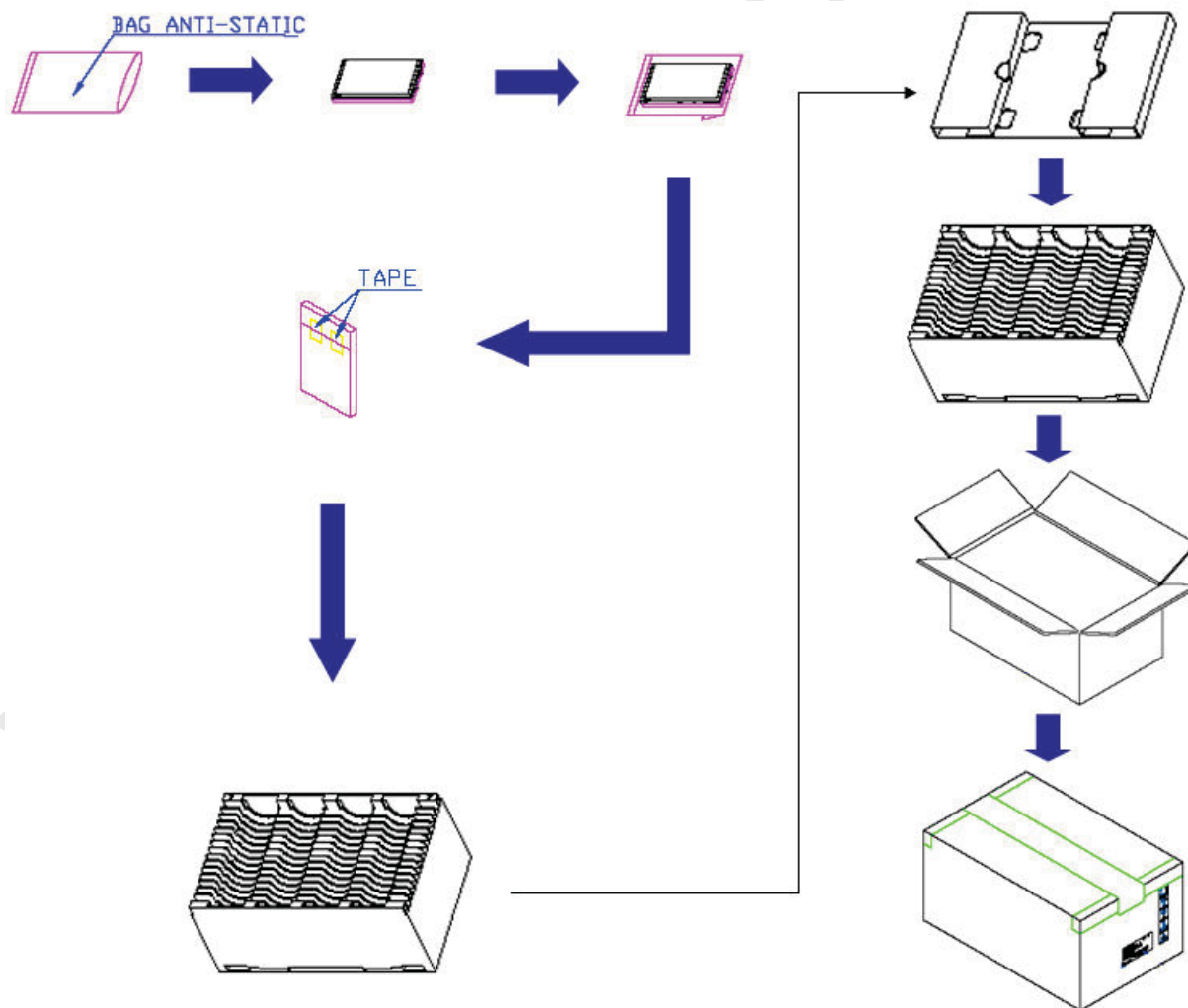

G057VTN01.0 Ver. 1.0

22/23



11 Safety

11.1 Keen Edge Requirements

There will be no keen edges or corners on the display assembly that could cause injury.

11.2 Materials

11.2.1 Toxicity

There will be no carcinogenic materials used anywhere in the TFT-LCD module. If toxic materials are used, they will be reviewed and approved by the responsible AUO toxicologist.

11.2.2 Flammability

All components including electrical components that do not meet the flammability grade UL94-V1 in the TFT-LCD Module will complete the flammability rating exception approval process.

The printed circuit board will be made from material rated 94-V1 or better. The actual UL flammability rating will be printed on the printed circuit board.

11.3 Capacitors

If any polarized capacitors are used in the TFT-LCD module, provisions will be made to keep them from being inserted backwards.

11.4 National Test Lab Requirement

The TFT-LCD Module will satisfy all requirements for compliance to UL 60950 (U.S.A. Information Technology Equipment).