

**TFT COLOR LCD MODULE
NL8060AC26-11**

**26 cm (10.4 type), 800 × 600 pixels, 262144 colors,
incorporated two lamps/edge-light type backlight**

DESCRIPTION

NL8060AC26-11 is a TFT (thin film transistor) active matrix color liquid crystal display (LCD) module comprising amorphous silicon TFT attached to each signal electrode, a driving circuit, and a backlight.

The 26 cm diagonal display area contains 800 × 600 pixels and can display 262144 color simultaneously.

NL8060AC26-11 is the same outline drawing and 26 cm diagonal display area as NL6448AC33-18. NL6448AC33-18 contains 640 × 480 pixels.

FEATURES

- High luminance (190 cd/m², typ.)
- Backlight with long-life-time lamps (two lamps, attached inverter)
- Easy to assemble with a touch panel
- Variable luminance control
- Replaceable the lamp holder
- 6-bit digital RGB signals

APPLICATIONS

- Personal computer (PC) for factory automation
- Display terminals for control system
- Monitors for process controller
- New media

STRUCTURE AND FUNCTIONS

A color TFT (thin film transistor) LCD module is comprised of a TFT liquid crystal panel structure, LSIs for driving the TFT array, and a backlight assembly. The TFT panel structure is created by sandwiching liquid crystal material in the narrow gap between a TFT array glass substrate and a color filter glass substrate. After the driver LSIs are connected to the panel, the backlight assembly is attached to the backside of the panel.

RGB (red, green, blue) data signals from a source system is modulated into a form suitable for active matrix addressing by the onboard signal processor and sent to the driver LSIs which in turn addresses the individual TFT cells.

Acting as an electro-optical switch, each TFT cell regulates light transmission from the backlight assembly when activated by the data source. By regulating the amount of light passing through the array of red, green, and blue dots, color images are created with clarity.

BLOCK DIAGRAM

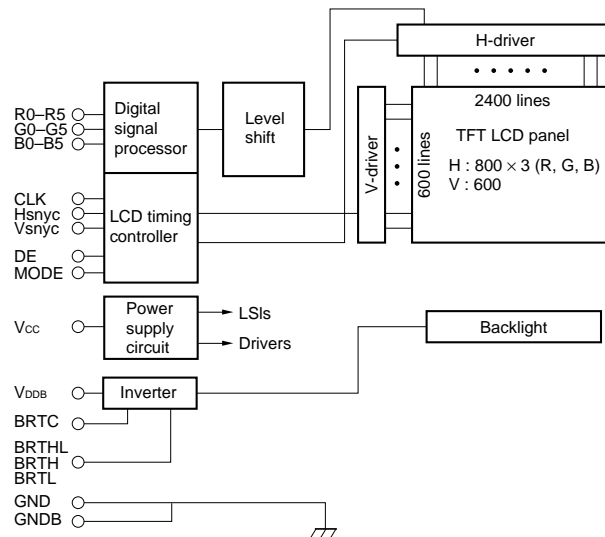

OUTLINE OF CHARACTERISTICS (at room temperature)

Display area	211.2 (H) × 158.4 (V) mm
Drive system	a-Si TFT active matrix
Display colors	262144 colors
Number of pixels	800 × 600 pixels
Pixel arrangement	RGB vertical stripe
Pixel pitch	0.264 (H) × 0.264 (V) mm
Module size	243.0 (H) × 185.1 (V) × 10.5 typ. (D) mm
Weight	465 g (typ.), LCD module + 15 g (typ., attached inverter)
Contrast ratio	150:1 (typ.)
Viewing angle (more than the contrast ratio of 10:1)	Horizontal : 45° (typ. left side, right side) Vertical : 20° (typ. up side), 45° (typ. down side)
Designed viewing direction	<ul style="list-style-type: none"> • Wider viewing angle with contrast ratio : down side (6 o'clock) • Wider viewing angle without image reversal: up side (12 o'clock) • Optimum grayscale ($\gamma = 2.2$) : perpendicular
Color gamut	42 % (typ. center, to NTSC)
Response time	40 ms (max.), "white" to "black"
Luminance	190 cd/m ² (typ.)
Signal system	6-bit digital signals for each of RGB primary colors, synchronous signals (Hsync, Vsync), dot clock (CLK)
Supply voltage	3.3 V [5.0 V] (Logic, LCD driving), 12 V (Backlight)
Backlight	Edge light type, one cold cathode fluorescent lamp, attached inverter
Power consumption	6.8 W (typ. at 3.3 V and 12 V)

GENERAL SPECIFICATIONS

Item	Specification	Unit
Module size	243.0 ± 0.5 (H) × 185.1 ± 0.5 (V) × 11.0 max.* (D)	mm
Inverter size	25.0 ± 0.5 (H) × 105.0 ^{+0.7} / _{-0.3} (V) × 10.2 max. (D)	mm
Display area	211.2 (H) × 158.4 (V)	mm
Number of pixels	800 (H) × 600 (V)	pixel
Dot pitch	0.088 (H) × 0.264 (V)	mm
Pixel pitch	0.264 (H) × 0.264 (V)	mm
Pixel arrangement	RGB (Red, Green, Blue) vertical stripe	
Display colors	262144	color
Weight	480 (max.) + 20 (max., attached inverter)	g

* D = 10.5 typ.

ABSOLUTE MAXIMUM RATINGS

Parameter	Symbol	Rating	Unit	Remarks
Supply voltage	V _{CC}	-0.3 to 6.5	V	V _I - V _{CC} < 3.0 T _a = 25 °C
Input voltage	V _I	-0.3 to 6.5	V	
Storage temp.	T _{ST}	-20 to 60	°C	
Operating temp.	T _{OP}	0 to 50	°C	Module surface*
Humidity (No condensation)		≤ 95 % relative humidity		T _a ≤ 40 °C
		≤ 85 % relative humidity		40 < T _a ≤ 50 °C
		Absolute humidity shall not exceed T _a = 50 °C, 85 % relative humidity level		T _a > 50 °C

* Measured at the display area

ELECTRICAL CHARACTERISTICS

(1) Logic, LCD driving

T_a = 25 °C

Parameter	Symbol	Min.	Typ.	Max.	Unit	Remarks
Supply voltage	V _{CC}	3.0 (4.75)	3.3 (5.0)	3.6 (5.25)	V	V _{CC} = 3.3 V (V _{CC} = 5.0 V)
Logic input "L" voltage	V _{IL}	0	-	V _{CC} × 0.3	V	
Logic input "H" voltage	V _{IH}	V _{CC} × 0.7	-	5.25	V	
Supply current	I _{CC}	-	*1 310 *1 (240)	*2 550 *2 (500)	mA	V _{CC} = 3.3 V (V _{CC} = 5.0 V)

*1. Checker flag pattern (in EIAJ ED-2522)

*2. Theoretical maximum current pattern

(2) Backlight

T_a = 25 °C

Parameter	Symbol	Min.	Typ.	Max.	Unit	Remarks
Supply current	I _{DDb}	–	480	550	mA	190 cd/m ²
Supply voltage	V _{DDb}	11.4	12.0	12.6	Vrms	–

SUPPLY VOLTAGE SEQUENCE

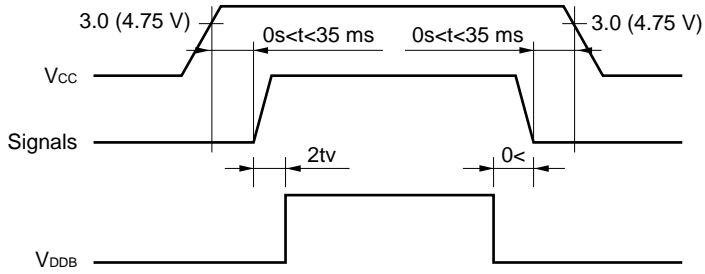

- *1 The supply voltage for input signals should be the same as V_{CC}.
- *2 Apply V_{DDb} within the LCD operation period. When the backlight turns on before LCD operation or the LCD operation turns off before the backlight turns off, the display may momentarily become white.
- *3 When the power is off, please keep whole signals (Hsync, Vsync, CLK, DE, data) low level or high impedance.

INTERFACE PIN CONNECTION

(1) Interface signals, power supply

Module side connector

CN1 ... DF9-41P-1V (No. 1 to 41)

Supplier: HIROSE ELECTRIC CO., LTD.

or

IL-310-T41P-VF (No. 1 to 41)

Supplier: Japan Aviation Electronics Industry limited (JAE)

Mating connector

DF9-41S-1V or DF9M-41S-1R

IL-310-T41S-VF

note: Mating connectors are possible to use all parts.

Pin No.	Symbol	Function
1	GND	Ground Note 3
2	DCLK	Dot clock
3	GND	Ground Note 3
4	Hsync	Horizontal sync.
5	Vsync	Vertical sync.
6	GND	Ground Note 3
7	GND	Ground Note 3
8	GND	Ground Note 3
9	R0	Red data (LSB)
10	R1	Red data
11	R2	Red data
12	GND	Ground Note 3
13	R3	Red data
14	R4	Red data
15	R5	Red data (MSB)
16	GND	Ground Note 3
17	GND	Ground Note 3
18	GND	Ground Note 3
19	G0	Green data (LSB)
20	G1	Green data
21	G2	Green data

Pin No.	Symbol	Function
22	GND	Ground Note 3
23	G3	Green data
24	G4	Green data
25	G5	Green data (MSB)
26	GND	Ground Note 3
27	GND	Ground Note 3
28	GND	Ground Note 3
29	B0	Blue data (LSB)
30	B1	Blue data
31	B2	Blue data
32	GND	Ground Note 3
33	B3	Blue data
34	B4	Blue data
35	B5	Blue data (MSB)
36	GND	Ground Note 3
37	DE	Data enable
38	Vcc	Power supply Note 1
39	Vcc	Power supply Note 1
40	Vcc	Power supply Note 1
41	MODE	Timing mode select Note 2

LSB : Least Significant Bit

MSB : Most Significant Bit

Notes 1. Vcc: All Vcc terminals should be connected to 3.3 V [5.0 V].

2. MODE: $\left\{ \begin{array}{l} \text{H} \\ \text{L or open} \end{array} \right.$ = Fixed mode
 $\left\{ \begin{array}{l} \text{L or open} \end{array} \right.$ = DE mode

3. GND is connected to the frame of the LCD module.

(2) Backlight

lamp side connector Mating connector
 CN2 ... BHR-03VS-1 SM02 (8.0) B-BHS-TB
 Supplier: J.S.T TRADING COMPANY, LTD.

Pin No.	Symbol	Function
1	GNDB	Backlight ground
2	VH	High voltage terminal
3	VH	High voltage terminal

Inverter side connector 1 Mating connector 1
 CN3 ... LZ-5P-SL-SMT LZ-5S-SC3
 Supplier: Japan Aviation Electronics Industry Limited (JAE)

Pin No.	Symbol	Function	Pin No.	Symbol	Function
1	V _{DDB}	Power supply	4	GNDB	Backlight ground
2	V _{DDB}	Power supply	5	BRTHL	Luminance select *1
3	GNDB	Backlight ground			

*1: High luminance (100 %) ... BRTHL = +5 V or open
 Low luminance (60 %) ... BRTHL = GND

Inverter side connector 2 Mating connector 2
 CM4 ... IL-Z-3PL-SMTY IL-Z-3S-S125C3
 Supplier: Japan Aviation Electronics Industry Limited (JAE)

Pin No.	Symbol	Function
1	BRTC	Backlight ON/OFF signal *1
2	BRTH	Luminance control input *2
3	BRTL	Luminance control input *2

*1: TTL level
 Backlight ON ... BRTC = H or Open
 Backlight OFF ... BRTC = L

*2: <1> A way of luminance control by a variable resistor
 This way works when BRTHL (No.5 pin) of CN3 is opened.

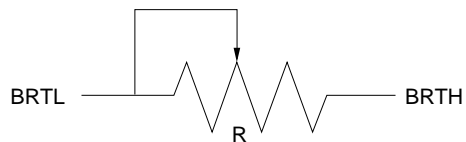

Mating variable resistor : 10 KΩ ±5 %
 Minimum luminance (50 %) : R = 0 Ω
 Maximum luminance (100 %) : R = 10 KΩ

<2> A way of luminance control by a voltage
 This way works when BRTHL and BRTL are opened. The range of input voltage between BRTH and GNDB is as follows.

- Minimum luminance (50 %) : 2.5 V
- Maximum luminance (100 %) : ≤ 1.2 V

(3) Connector location

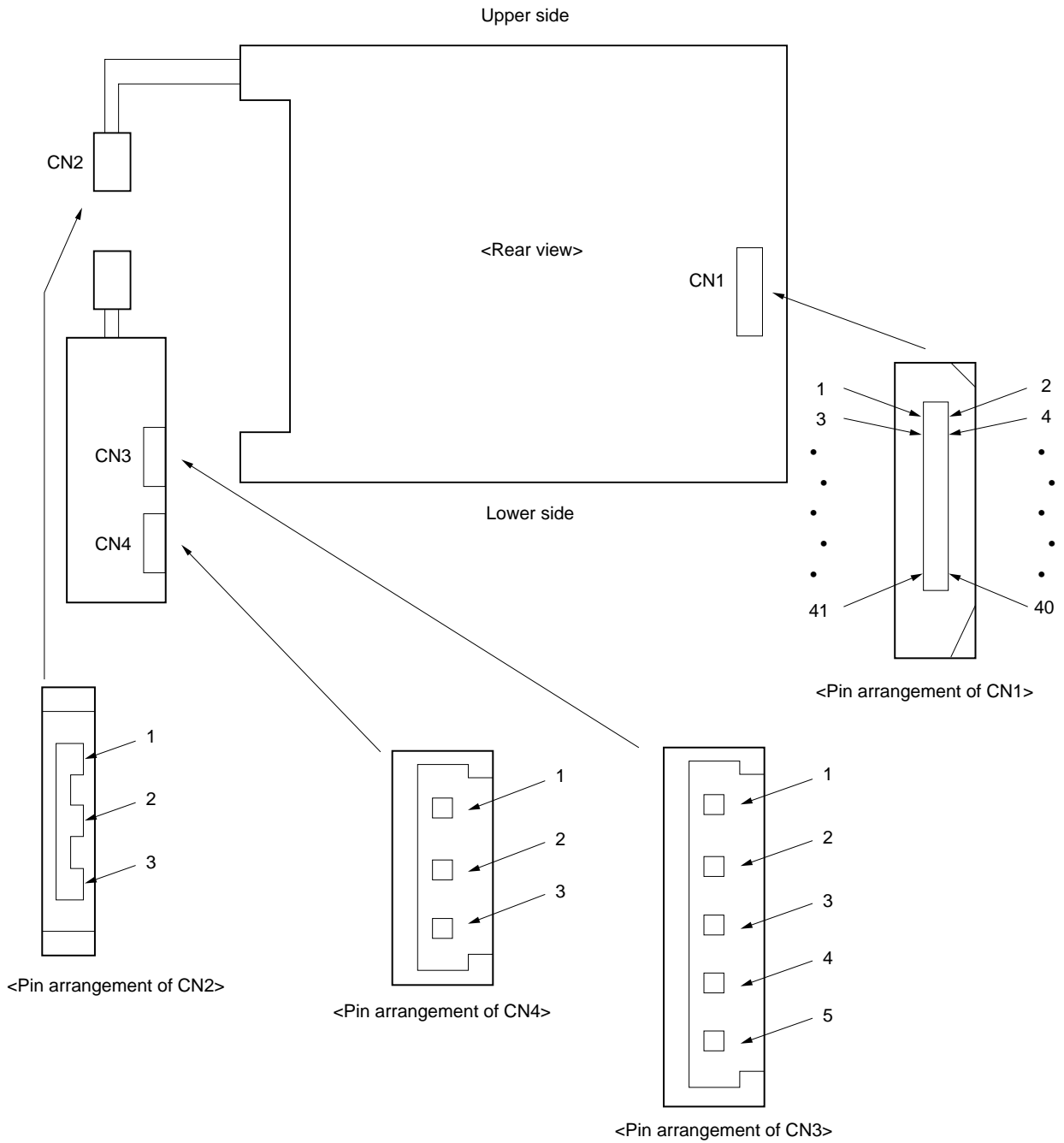

DISPLAY COLORS vs. INPUT DATA SIGNALS

Display colors		Data signal (0: Low level, 1: High level)																	
		R5	R4	R3	R2	R1	R0	G5	G4	G3	G2	G1	G0	B5	B4	B3	B2	B1	B0
Basic colors	Black	0	0	0	0	0	0	0	0	0	0	0	0	0	0	0	0	0	0
	Blue	0	0	0	0	0	0	0	0	0	0	0	0	1	1	1	1	1	1
	Red	1	1	1	1	1	1	0	0	0	0	0	0	0	0	0	0	0	0
	Magenta	1	1	1	1	1	1	0	0	0	0	0	0	1	1	1	1	1	1
	Green	0	0	0	0	0	0	1	1	1	1	1	1	0	0	0	0	0	0
	Cyan	0	0	0	0	0	0	1	1	1	1	1	1	1	1	1	1	1	1
	Yellow	1	1	1	1	1	1	1	1	1	1	1	1	0	0	0	0	0	0
	White	1	1	1	1	1	1	1	1	1	1	1	1	1	1	1	1	1	1
Red grayscale	Black	0	0	0	0	0	0	0	0	0	0	0	0	0	0	0	0	0	0
	Dark	0	0	0	0	0	1	0	0	0	0	0	0	0	0	0	0	0	0
	↑																		
	↓																		
	Bright	1	1	1	1	0	1	0	0	0	0	0	0	0	0	0	0	0	0
Red	1	1	1	1	1	1	0	0	0	0	0	0	0	0	0	0	0	0	
Green grayscale	Black	0	0	0	0	0	0	0	0	0	0	0	0	0	0	0	0	0	0
	Dark	0	0	0	0	0	0	0	0	0	0	0	1	0	0	0	0	0	0
	↑																		
	↓																		
	Bright	0	0	0	0	0	0	1	1	1	1	0	1	0	0	0	0	0	0
Green	0	0	0	0	0	0	1	1	1	1	1	0	0	0	0	0	0	0	
Blue grayscale	Black	0	0	0	0	0	0	0	0	0	0	0	0	0	0	0	0	0	0
	Dark	0	0	0	0	0	0	0	0	0	0	0	0	0	0	0	0	1	0
	↑																		
	↓																		
	Bright	0	0	0	0	0	0	0	0	0	0	0	0	1	1	1	1	0	1
Blue	0	0	0	0	0	0	0	0	0	0	0	0	1	1	1	1	1	0	
Blue	0	0	0	0	0	0	0	0	0	0	0	0	1	1	1	1	1	1	

Note Colors are developed in combination with 6-bit signals (64 steps in grayscale) of each primary red, green, and blue color.

This process can result in up to 262144 (64 × 64 × 64) colors.

INPUT SIGNAL TIMING

(1) Input signal specifications

Parameter		Symbol	Min.	Typ.	Max.	Unit	Remarks
CLK	Frequency	1/tc	34.0	38.362	40.0	MHz	26.067 ns (TYP.)
	Duty	tch/tc	0.4	0.5	0.6	–	
	Rise, fall	tcrf	–	–	10	ns	
Hsync	Period	th	24.3	26.693	–	μs	37.463 kHz (TYP.)
			–	1024	–	CLK	
	Display period	thd	800			CLK	
	Front-porch	thf	24			CLK	fixed timing mode
			4	24	–	CLK	DE mode
	Pulse width	thp*	2	72	127	CLK	fixed timing mode
			2	72	127	CLK	DE mode
	Back-porch	thb*	73	128	198	CLK	fixed timing mode
			13	128	509	CLK	DE mode
	thp + thb*		200			CLK	fixed timing mode
			15	200	511	CLK	DE mode
	CLK-Hsync timing	thch	10	–	–	ns	
	Hsync-CLK timing	thcs	8	–	–	ns	
	Hsync-Vsync timing	tvhh	1	–	–	CLK	
	Vsync-Hsync timing	tvhs	15	–	–	ns	
Rise, fall	thrf	–	–	10	ns		
Vsync	Period	tv	16.1	16.683	17.2	ms	59.94 Hz (TYP.)
			–	625	–	H	
	Display period	tvd	600			H	
	Front-porch	tvf	1			H	fixed timing mode
			1	1	–	H	DE mode
	Pulse width	tvp*	1	2	23	H	fixed timing mode
			1	2	–	H	DE mode
	Back-porch	tvb*	1	22	23	H	fixed timing mode
			1	22	–	H	DE mode
tvp + tvb*		24			H	fixed timing mode	
		2	24	24	H	DE mode	
Rise, fall	tvrf	–	–	10	ns		
DATA R0 - R5 G0 - G5 B0 - B5	CLK-DATA timing	tds	8	–	–	ns	
	DATA-CLK timing	tdh	10	–	–	ns	
	Rise, fall	tdrf	–	–	10	ns	
DE	DE-CLK timing	tes	8	–	–	ns	DE mode
	CLK-DE timing	teh	10	–	–	ns	
	Rise, fall	terf	–	–	10	ns	

All of parameters should be kept in the specified range.

(2) Definition of input signal timing

<Vertical>

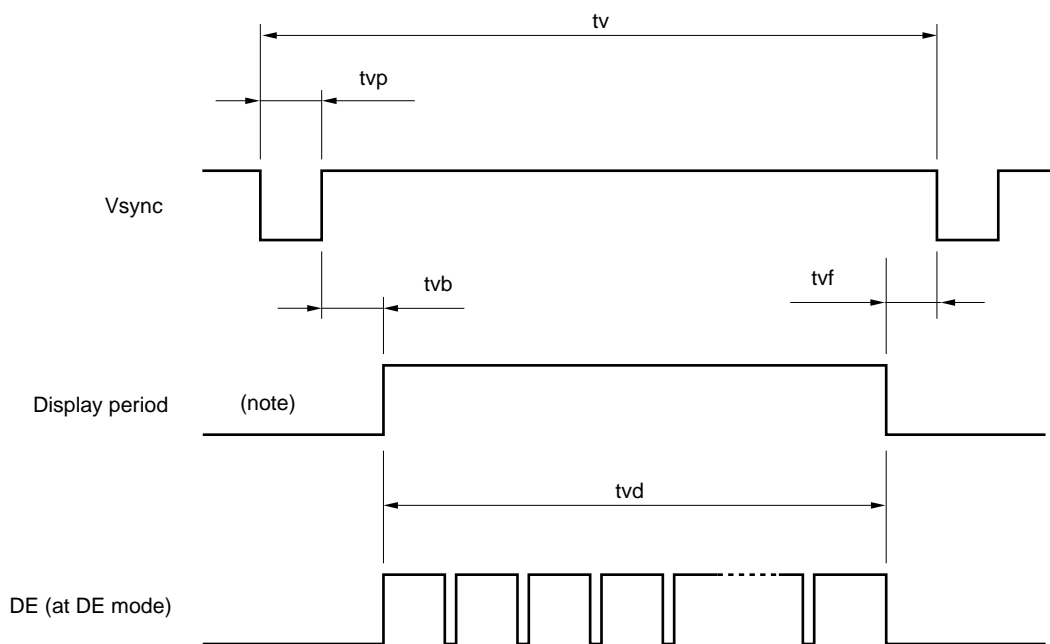

<Horizontal>

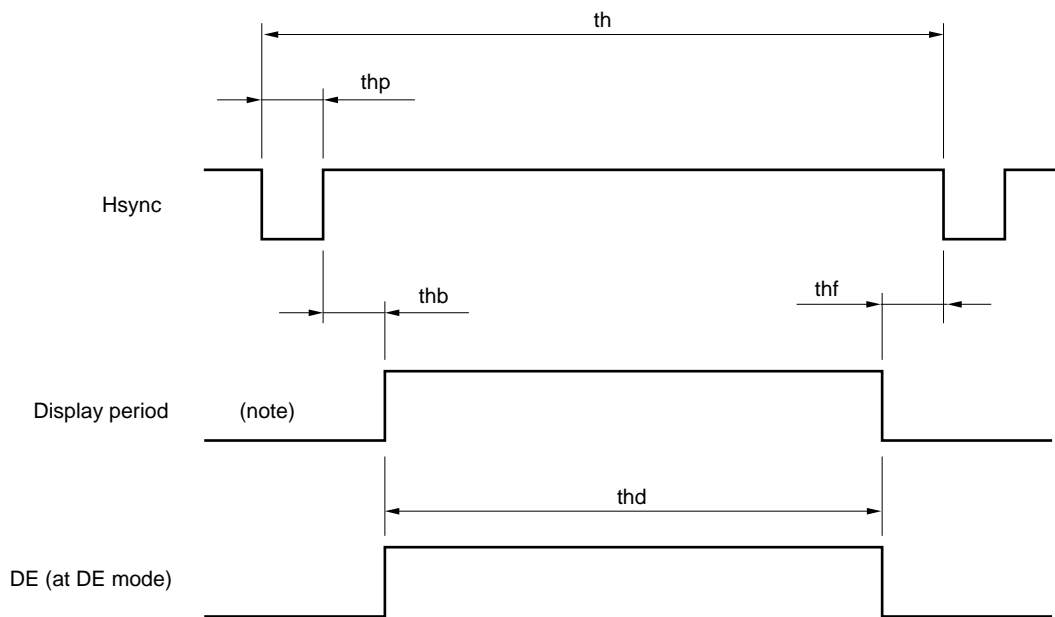

Note These do not exist as signals.

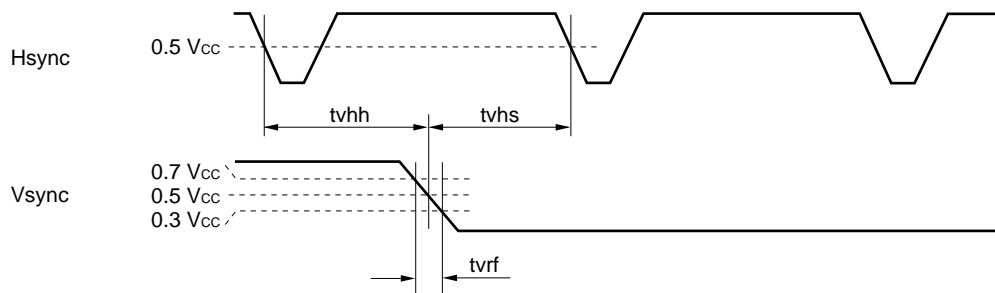
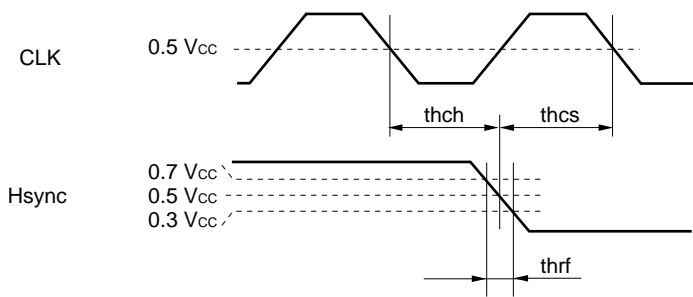
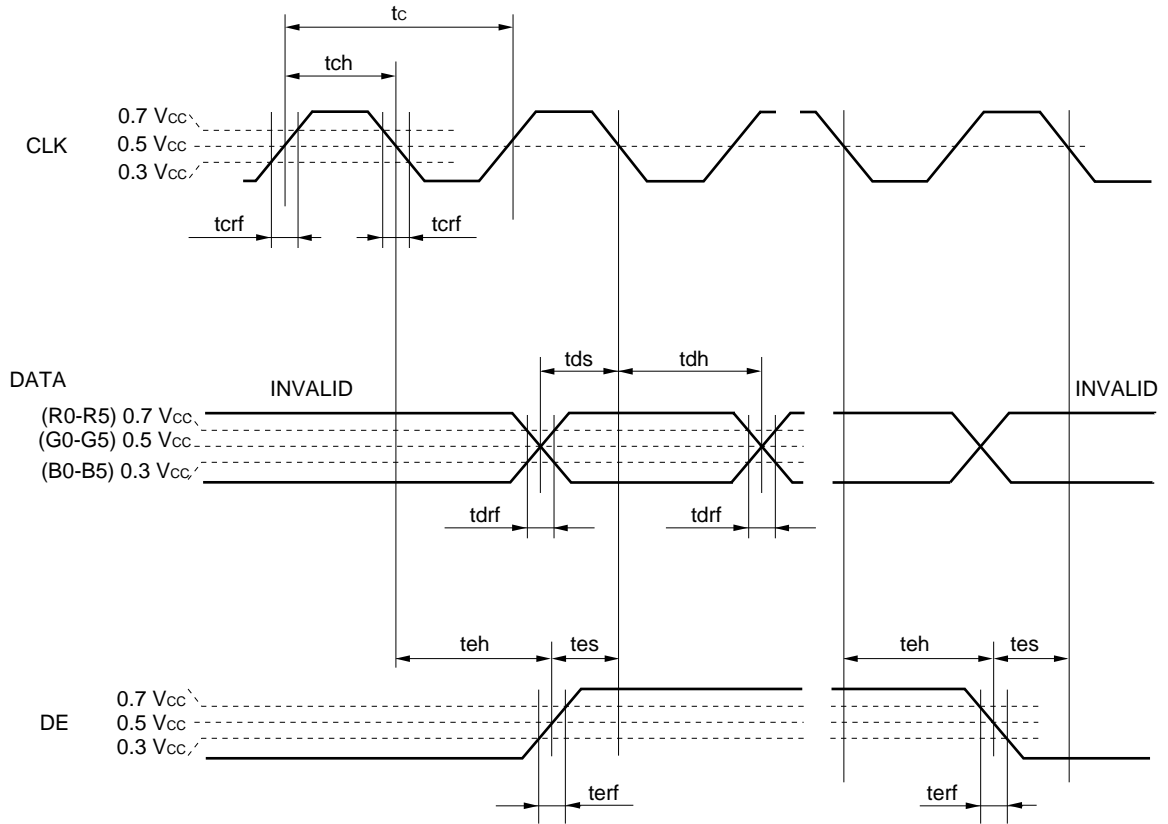

(3) Input signal timing chart

a) Fixed timing mode

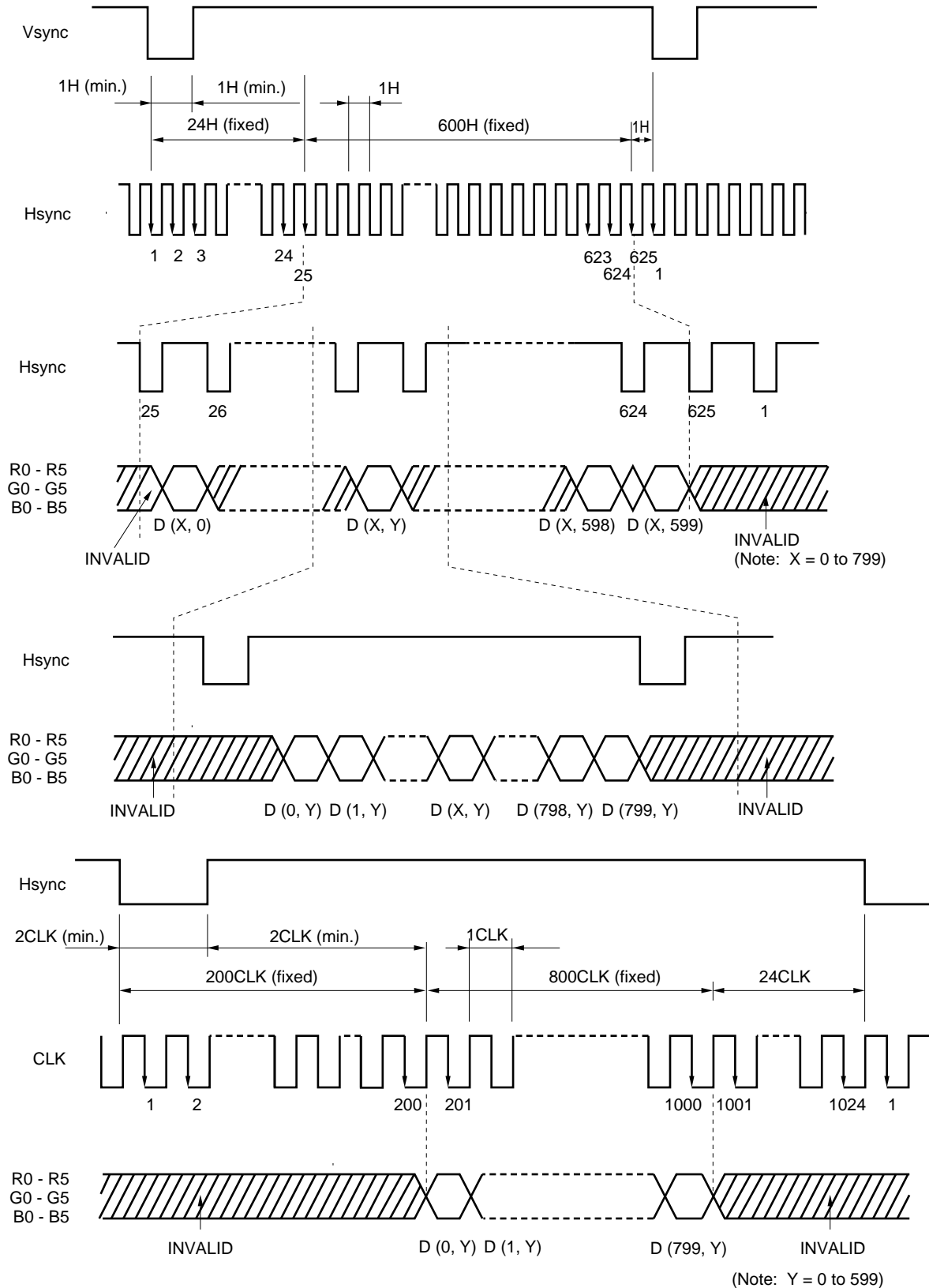

b) DE mode

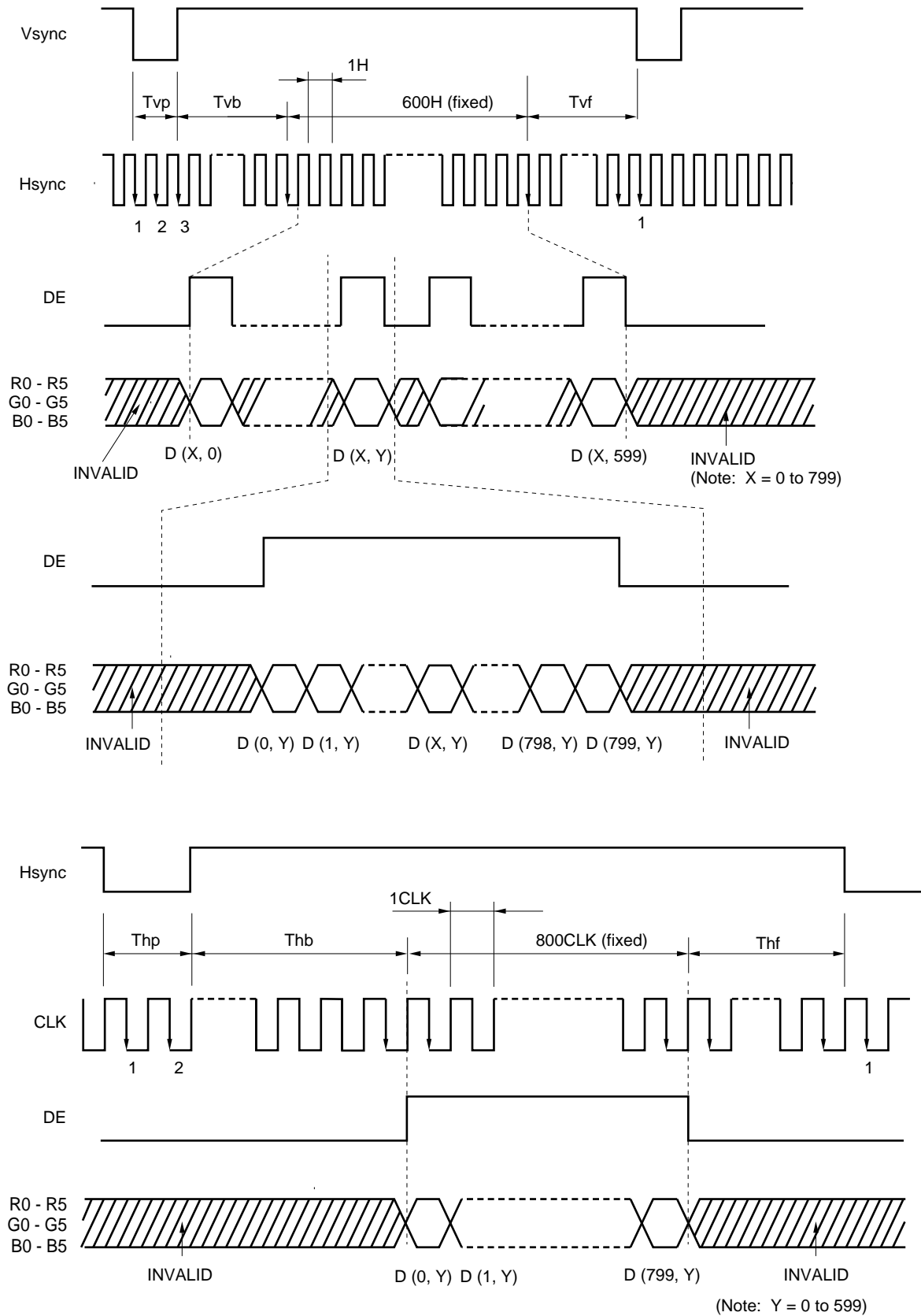

(4) Display position

D (0, 0)	D (1, 0)	-----	D (X, 0)	-----	D (798, 0)	D (799, 0)
D (0, 1)	D (1, 1)	-----	D (X, 1)	-----	D (798, 1)	D (799, 1)
⋮	⋮	-----	⋮	-----	⋮	⋮
D (0, Y)	D (1, Y)	-----	D (X, Y)	-----	D (798, Y)	D (799, Y)
⋮	⋮	-----	⋮	-----	⋮	⋮
D (0, 598)	D (1, 598)	-----	D (X, 598)	-----	D (798, 598)	D (799, 598)
D (0, 599)	D (1, 599)	-----	D (X, 599)	-----	D (798, 599)	D (799, 599)

GENERAL CAUTION

- (1) Caution when taking out the module
 - 1) Pick the pouch only, when taking out module from a shipping package.
- (2) Cautions for handling the module
 - 1) As the electrostatic discharges may break the LCD module, handle the LCD module with care. Peel a protection sheet off from the LCD panel surface as slowly as possible.
 - 2) As the LCD panel and back-light element are made from fragile glass material, impulse and pressure to the LCD module should be avoided.
 - 3) As the surface of polarizer is very soft and easily scratched, use a soft dry cloth without chemicals for cleaning.
 - 4) Do not pull the interface connectors in or out while the LCD module is operating.
 - 5) Put the module display side down on a flat horizontal plane.
 - 6) Handle connectors and cables with care.
 - 7) The torque to mounting screw should never exceed 0.294 N•m (3 Kgf•cm).
- (3) Cautions for the operation
 - 1) When the module is operating, do not lose CILK, Hsync or Vsync signals. If any one of these signals is lost, the LCD panel would be damaged.
 - 2) Obey the supply voltage sequence. If wrong sequence is applied, the module would be damaged.
- (4) Cautions for the atmosphere
 - 1) Dew drop atmosphere should be avoided.
 - 2) Do not store and/or operate the LCD module in a high temperature and/or humidity atmosphere. Storage in an electro-conductive polymer packing pouch and under relatively low temperature atmosphere is recommended.
 - 3) This module uses cold cathode fluorescent lamps. Therefore, the life time of lamps becomes short conspicuously at low temperature.
- (5) Cautions for the module characteristics
 - 1) Do not apply fixed pattern data signal to the LCD module at product aging. Applying fixed pattern for a long time may cause image sticking.
- (6) Other cautions
 - 1) Do not disassemble and/or re-assemble LCD module.
 - 2) Do not re-adjust variable resistor or switch etc.
 - 3) When returning the module for repair or etc., Please pack the module not to be broken.
We recommend to use the original shipping packages.

Liquid Crystal Display has the following specific characteristics. These are not defects or malfunctions. The display condition of LCD module may be affected by the ambient temperature. The LCD module uses cold cathode tubes for backlighting. Optical characteristics, like luminance or uniformity, will change during time. Uneven brightness and/or small spots may be noticed depending on different display patterns.

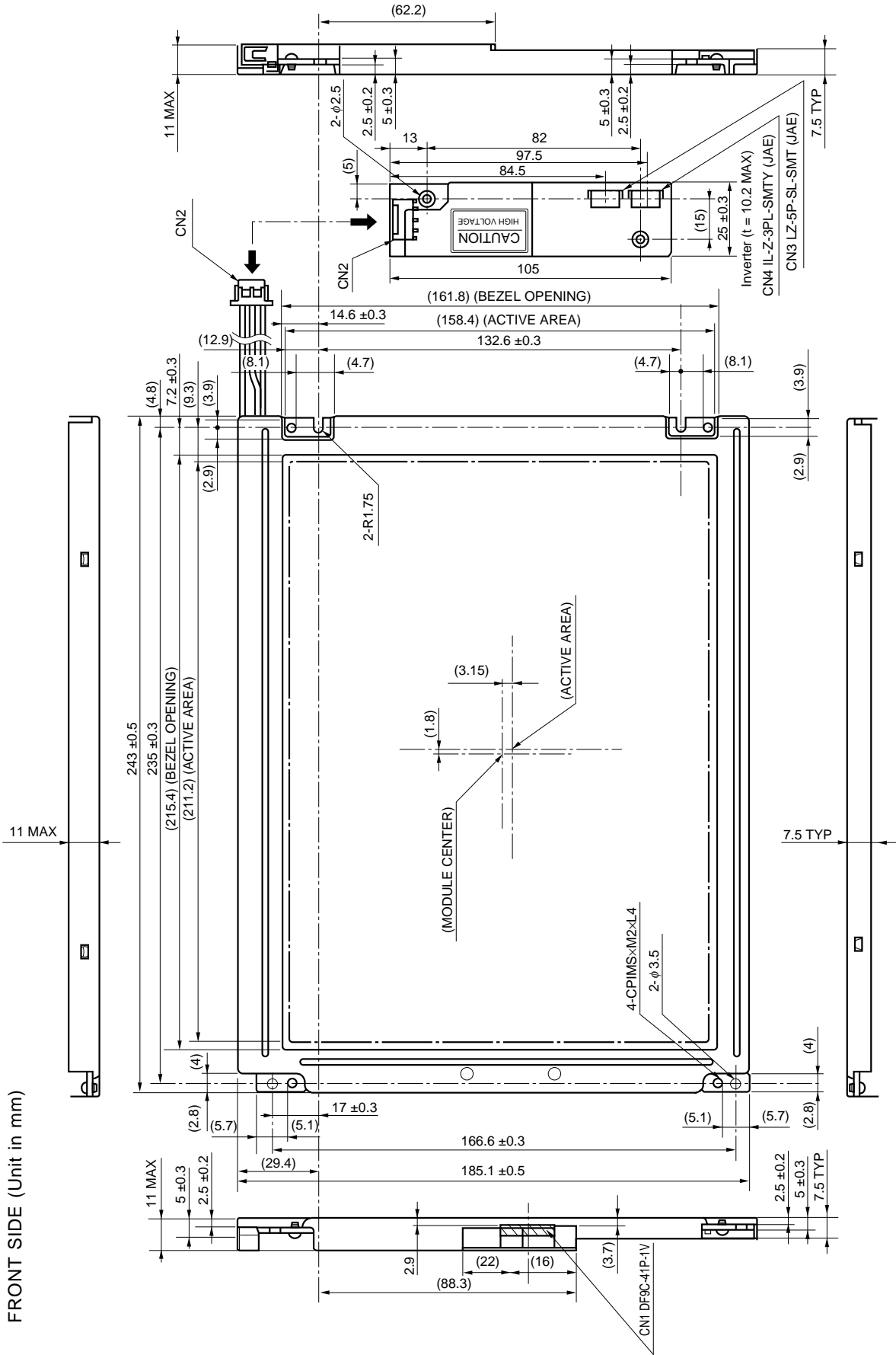

OUTLINE DRAWING
FRONT SIDE (Unit in mm)

* The torque to mounting screw should never exceed 0.294 N·m (3Kgf·cm).

OUTLINE DRAWING
REAR SIDE (Unit in mm)

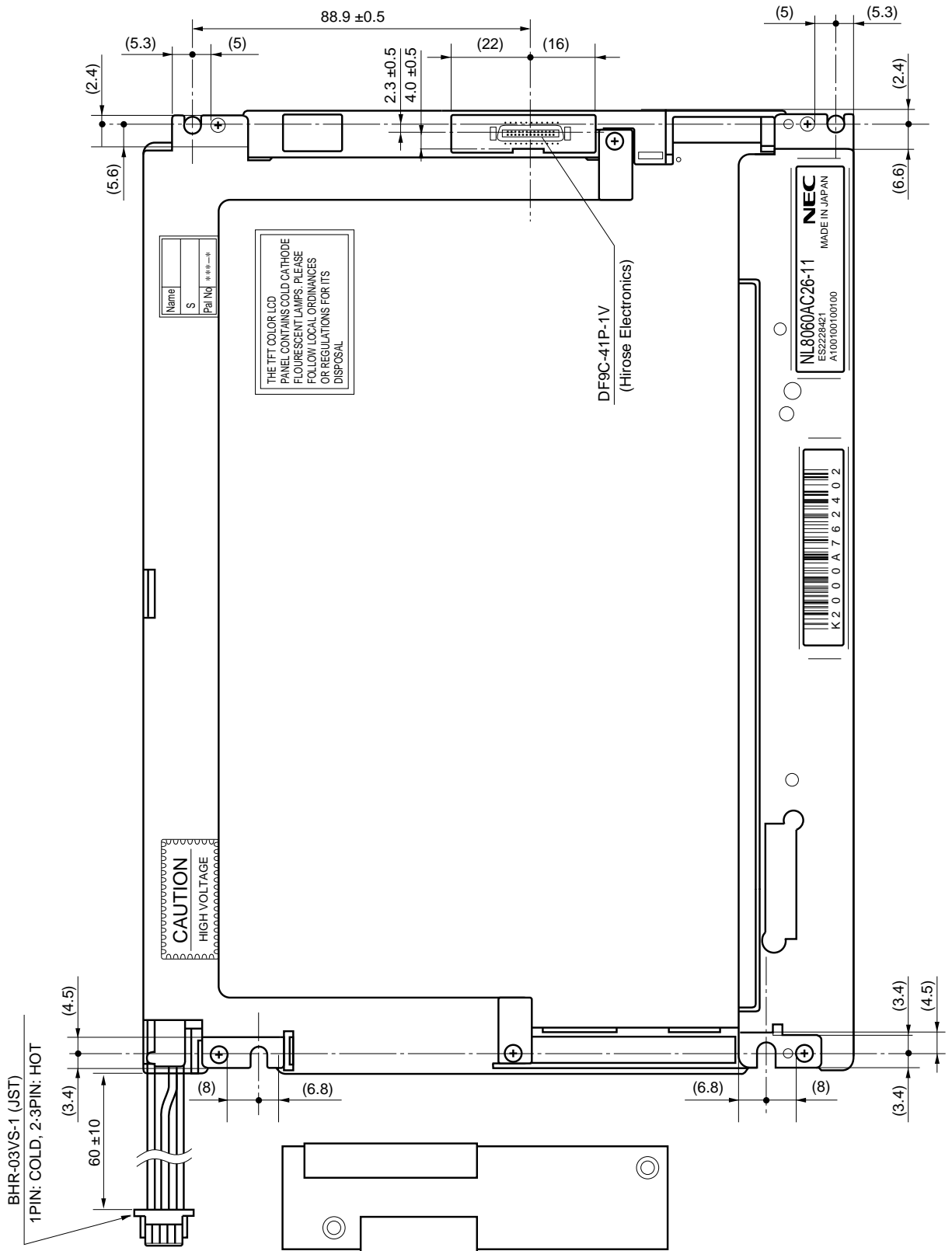

No part of this document may be copied in any form or by any means without the prior written consent of NEC Corporation.

NEC Corporation does not assume any liability for infringement of patents, copyrights or other intellectual property rights of third parties by or arising from use of a device described herein or any other liability arising from use of such device. No license, either express, implied or otherwise, is granted under any patents, copyrights or other intellectual property rights of NEC Corporation or of others.