

**26 cm (10.4 type), 800 × 600 pixels, 262144 colors,
incorporated one lamp/edge-light type backlight**

DESCRIPTION

NL8060AC26-04 is a TFT (thin film transistor) active matrix color liquid crystal display (LCD) module comprising amorphous silicon TFT attached to each signal electrode, a driving circuit, and a backlight.

The 26 cm diagonal display area contains 800 × 600 pixels and can display 262144 color simultaneously.

By utilizing one lamp/edge-light type backlight, a very thin profile and low power consumption have been achieved.

FEATURES

- 6-bit digital RGB signals
- 3.3 V operation (5.0 V available)
- Thin and light weight
- Low reflection
- Low power consumption
- Incorporated edge light type backlight (One lamp, Inverter-less)
- Data enable function
- Approved to UL1950, 2nd Edition and CAN/CSA-C22.2 No. 950-93

APPLICATIONS

- Personal computer (PC), word processor
- Display terminals for control system
- New media
- Monitors for process controller

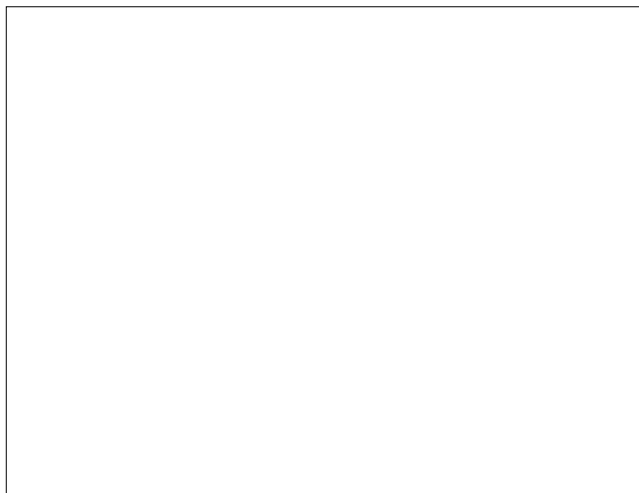

STRUCTURE AND FUNCTIONS

A TFT color LCD module comprises a TFT LCD panel, LSIs for driving liquid crystal, and the backlight. The TFT LCD panel is composed of a TFT array glass substrate superimposed on a color filter glass substrate with liquid crystal filled in the narrow gap between two substrates. The backlight apparatus is located on the backside of the LCD panel.

RGB (Red, Green, Blue) data signals are sent to LCD panel drivers after modulation into suitable forms for active matrix addressing through signal processor.

Each of the liquid crystal cells acts as an electro-optical switch that controls the light transmission from the backlight by a signal applied to a signal electrode through the TFT switch.

BLOCK DIAGRAM

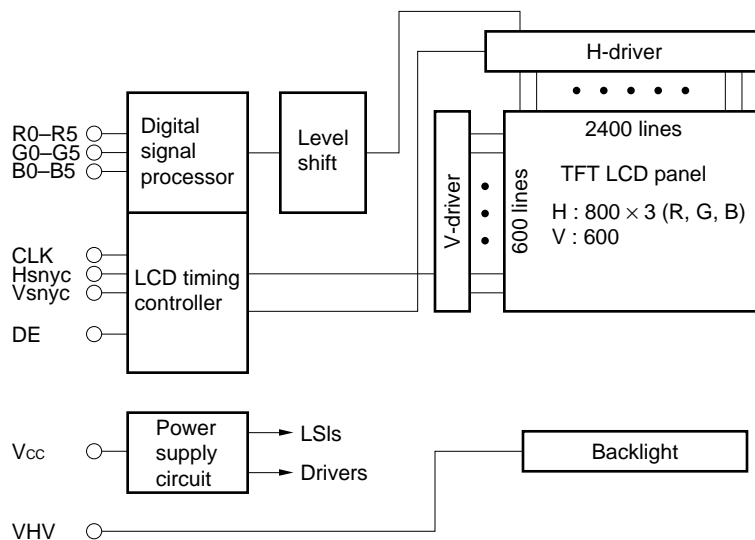

OUTLINE OF CHARACTERISTICS (at room temperature)

Display area	211.2 (H) × 158.4 (V) mm
Drive system	a-Si TFT active matrix
Display colors	262144 colors
Number of pixels	800 × 600 pixels
Pixel arrangement	RGB vertical stripe
Pixel pitch	0.264 (H) × 0.264 (V) mm
Module size	243.0 (H) × 179.0 (V) × 8.0 max. (D) mm
Weight	385 g (typ.)
Contrast ratio	150:1 (typ.)
Viewing angle (more than the contrast ratio of 10:1)	Horizontal : 45° (typ. left side, right side) Vertical : 20° (typ. up side), 40° (typ. down side)
Designed viewing direction	<ul style="list-style-type: none"> • Wider viewing angle with contrast ratio : down side (6 o'clock) • Wider viewing angle without image reversal: up side (12 o'clock) • Optimum grayscale ($\gamma = 2.2$) : perpendicular
Color gamut	42 % (typ. center, to NTSC)
Response time	40 ms (max.), "white" to "black"
Luminance	70 cd/m ² (typ.) (Lamp current: 2.9 mArms)
Signal system	6-bit digital signals for each of RGB primary colors, synchronous signals (Hsync, Vsync), dot clock (CLK)
Supply voltage	3.3 V [5.0 V] (Logic, LCD driving)
Backlight	Edge light type, one cold cathode fluorescent lamp, inverter-less
Power consumption	2.4 W (typ. at 3.3 V, 70 cd/m ²)

GENERAL SPECIFICATIONS

Item	Specification	Unit
Module size	243.0 ± 0.5 (H) × 179.0 ± 0.5 (V) × 8.0 max.* (D)	mm
Display area	211.2 (H) × 158.4 (V)	mm
Number of pixels	800 (H) × 600 (V)	pixel
Dot pitch	0.088 (H) × 0.264 (V)	mm
Pixel pitch	0.264 (H) × 0.264 (V)	mm
Pixel arrangement	RGB (Red, Green, Blue) vertical stripe	
Display colors	262144	color
Weight	400 (max.)	g

* D = 7.5 typ.

ABSOLUTE MAXIMUM RATINGS

Parameter	Symbol	Rating	Unit	Remarks	
Supply voltage	V _{CC}	-0.3 to 6.5	V		T _a = 25 °C
Input voltage	V _I	-0.3 to 6.5	V	V _I < V _{CC} + 3.0	
Storage temp.	T _{ST}	-20 to 60	°C		
Operating temp.	T _{OP}	0 to 50	°C	Module surface*	
Humidity		≤ 95 % relative humidity		T _a = 40 °C	No condensation
		≤ 85 % relative humidity		T _a = 50 °C	
		Absolute humidity shall not exceed T _a = 50 °C, 85 % relative humidity level		T _a > 50 °C	

* Measured at the display area

ELECTRICAL CHARACTERISTICS

(1) Logic, LCD driving

T_a = 25 °C

Parameter	Symbol	Min.	Typ.	Max.	Unit	Remarks
Supply voltage	V _{CC}	3.0 (4.75)	3.3 (5.0)	3.6 (5.25)	V	V _{CC} = 3.3 V (V _{CC} = 5.0 V)
Logic input "L" voltage	V _{IL}	0	-	V _{CC} × 0.3	V	
Logic input "H" voltage	V _{IH}	V _{CC} × 0.7	-	5.25	V	
Supply current	I _{CC}	-	*1 310 *1 (240)	*2 550 *2 (500)	mA	V _{CC} = 3.3 V (V _{CC} = 5.0 V)

*1. Checker flag pattern (in EIAJ ED-2522)

*2. Theoretical maximum current pattern

(2) Backlight

T_a = 25 °C

Parameter	Symbol	Min.	Typ.	Max.	Unit	Remarks
Lamp current	I _L	2.0	2.9	5.0	mArms	70 cd/m ² : 2.9 mArms (typ.) 90 cd/m ² : 3.5 mArms (typ.)
Lamp voltage	V _L	–	480	–	Vrms	
Lamp turn on voltage	V _s	650	1200	–	Vrms	T _a = 0 °C
		450	600	–	Vrms	T _a = 25 °C
Oscillator frequency	F _t	50	54	58	kHz	Note

Note Recommended value of “Ft”

- Ft is within the specification.
and

- $F_t = \frac{1}{4Th} \times (2n-1)$ Th: Hsync period
n : a natural number (1, 2, 3,)

If Ft is out of the recommended value, interference between Ft frequency and Hsync frequency may cause beat on the display.

SUPPLY VOLTAGE SEQUENCE

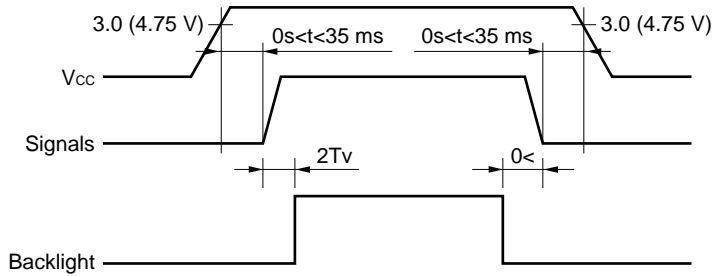

- *1 The supply voltage for input signals should be the same as Vcc.
- *2 Apply VHV within the LCD operation period. When the backlight turns on before LCD operation or the LCD operation turns off before the backlight turns off, the display may momentarily become white.
- *3 When the power is off, please keep whole signals (Hsync, Vsync, CLK, DE, data) low level or high impedance.

INTERFACE PIN CONNECTION

(1) Interface signals, power supply

module side connector

CN1 ... DF9-41P-IV (No. 1 to 41)

Supplier: Japan Aviation Electronics Industry Limited (JAE)

mating connector

DF9X-41S-IV (X ... A, B, C)

Pin No.	Symbol	Function
1	GND	Ground Note 3
2	DCLK	Dot clock
3	GND	Ground Note 3
4	Hsync	Horizontal sync.
5	Vsync	Vertical sync.
6	GND	Ground Note 3
7	GND	Ground Note 3
8	GND	Ground Note 3
9	R0	Red data (LSB)
10	R1	Red data
11	R2	Red data
12	GND	Ground Note 3
13	R3	Red data
14	R4	Red data
15	R5	Red data (MSB)
16	GND	Ground Note 3
17	GND	Ground Note 3
18	GND	Ground Note 3
19	G0	Green data (LSB)
20	G1	Green data
21	G2	Green data

Pin No.	Symbol	Function
22	GND	Ground Note 3
23	G3	Green data
24	G4	Green data
25	G5	Green data (MSB)
26	GND	Ground Note 3
27	GND	Ground Note 3
28	GND	Ground Note 3
29	B0	Blue data (LSB)
30	B1	Blue data
31	B2	Blue data
32	GND	Ground Note 3
33	B3	Blue data
34	B4	Blue data
35	B5	Blue data (MSB)
36	GND	Ground Note 3
37	DE	Data enable
38	V _{CC}	Power supply Note 1
39	V _{CC}	Power supply Note 1
40	V _{CC}	Power supply Note 1
41	MODE	Timing mode select Note 2

LSB : Least Significant Bit

MSB : Most Significant Bit

Notes 1. V_{CC}: All V_{CC} terminals should be connected to +3.3 V [+5.0 V].

2. MODE: $\begin{cases} H & = \text{Fixed mode} \\ L \text{ or open} & = \text{DE mode} \end{cases}$

3. GND is connected to the frame of the LCD module.

(2) Backlight

lamp side connector

CN2 ... BHR-03VS-1

Supplier: J.S.T TRADING COMPANY, LTD

mating connector

SM02 (8.0) B-BHS-TB

Pin No.	Symbol	Function
1	VHV	High voltage terminal
2	N. C.	Non-connection
3	GND	Backlight ground

<Connector location>

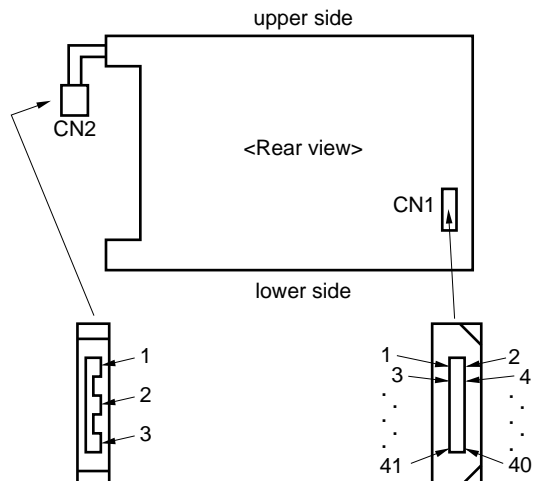

<pin arrangement of CN2>

<pin arrangement of CN1>

DISPLAY COLORS vs. INPUT DATA SIGNALS

Display colors		Data signal (0: Low level, 1: High level)																	
		R5	R4	R3	R2	R1	R0	G5	G4	G3	G2	G1	G0	B5	B4	B3	B2	B1	B0
Basic colors	Black	0	0	0	0	0	0	0	0	0	0	0	0	0	0	0	0	0	0
	Blue	0	0	0	0	0	0	0	0	0	0	0	0	1	1	1	1	1	1
	Red	1	1	1	1	1	1	0	0	0	0	0	0	0	0	0	0	0	0
	Magenta	1	1	1	1	1	1	0	0	0	0	0	0	1	1	1	1	1	1
	Green	0	0	0	0	0	0	1	1	1	1	1	1	0	0	0	0	0	0
	Cyan	0	0	0	0	0	0	1	1	1	1	1	1	1	1	1	1	1	1
	Yellow	1	1	1	1	1	1	1	1	1	1	1	1	0	0	0	0	0	0
	White	1	1	1	1	1	1	1	1	1	1	1	1	1	1	1	1	1	1
Red grayscale	Black	0	0	0	0	0	0	0	0	0	0	0	0	0	0	0	0	0	0
	Dark	0	0	0	0	0	1	0	0	0	0	0	0	0	0	0	0	0	0
	↑																		
	↓																		
	Bright	1	1	1	1	0	1	0	0	0	0	0	0	0	0	0	0	0	0
Green grayscale	Black	0	0	0	0	0	0	0	0	0	0	0	0	0	0	0	0	0	0
	Dark	0	0	0	0	0	0	0	0	0	0	0	1	0	0	0	0	0	0
	↑																		
	↓																		
	Bright	0	0	0	0	0	0	1	1	1	1	0	1	0	0	0	0	0	0
Blue grayscale	Black	0	0	0	0	0	0	0	0	0	0	0	0	0	0	0	0	0	0
	Dark	0	0	0	0	0	0	0	0	0	0	0	0	0	0	0	0	0	1
	↑																		
	↓																		
	Bright	0	0	0	0	0	0	0	0	0	0	0	0	1	1	1	1	0	1
Blue grayscale	Black	0	0	0	0	0	0	0	0	0	0	0	0	0	0	0	0	0	1
	Dark	0	0	0	0	0	0	0	0	0	0	0	0	0	0	0	0	1	0
	↑																		
	↓																		
	Blue	0	0	0	0	0	0	0	0	0	0	0	0	1	1	1	1	1	1

Note Colors are developed in combination with 6-bit signals (64 steps in grayscale) of each primary red, green, and blue color.

This process can result in up to 262144 (64 × 64 × 64) colors.

INPUT SIGNAL TIMING

(1) Input signal specifications

Parameter		Symbol	Min.	Typ.	Max.	Unit	Remarks
CLK	Frequency	1/Tc	34.0	38.362	40.0	MHz	26.067 ns (TYP.)
	Duty	Tch/Tc	0.4	0.5	0.6	-	
	Rise, fall	Tcrf	-	-	10	ns	
Hsync	Period	Th	24.3	26.693	-	μs	37.463 kHz (TYP.)
			-	1024	-	CLK	
	Display period	Thd	800			CLK	
	Front-porch	Thf	-	24	-	CLK	fixed timing mode
			4	24	-	CLK	DE mode
	Pulse width	Thp*	2	72	198	CLK	fixed timing mode
			2	72	-	CLK	DE mode
	Back-porch	Thb*	2	128	198	CLK	fixed timing mode
			2	128	-	CLK	DE mode
	Thp + Thb*		200			CLK	fixed timing mode
			15	200	-	CLK	DE mode
	CLK-Hsync timing	Thch	10	-	-	ns	
	Hsync-CLK timing	Thcs	8	-	-	ns	
	Hsync-Vsync timing	Tvhh	1	-	-	CLK	
	Vsync-Hsync timing	Tvhs	15	-	-	ns	
Rise, fall	Thrf	-	-	10	ns		
Vsync	Period	Tv	16.1	16.683	17.2	ms	59.94 Hz (TYP.)
			-	625	-	H	
	Display period	Tvd	600			H	
	Front-porch	Tvf	-	1	-	H	fixed timing mode
			1	1	-	H	DE mode
	Pulse width	Tvp*	1	2	22	H	fixed timing mode
			1	2	-	H	DE mode
	Back-porch	Tvb*	1	22	22	H	fixed timing mode
			1	22	-	H	DE mode
Tvp + Tvb*		24			H	fixed timing mode	
		2	24	254	H	DE mode	
Rise, fall	Tvrf	-	-	10	ns		
DATA R0 - R5 G0 - G5 B0 - B5	CLK-DATA timing	Tds	7	-	-	ns	
	DATA-CLK timing	Tdh	11	-	-	ns	
	Rise, fall	Tdrf	-	-	10	ns	
DE	DE-CLK timing	Tes	7	-	-	ns	DE mode
	CLK-DE timing	Teh	11	-	-	ns	
	Rise, fall	Terf	-	-	10	ns	

All of parameters should be kept in the specified range.

(2) Definition of input signal timing

<Vertical>

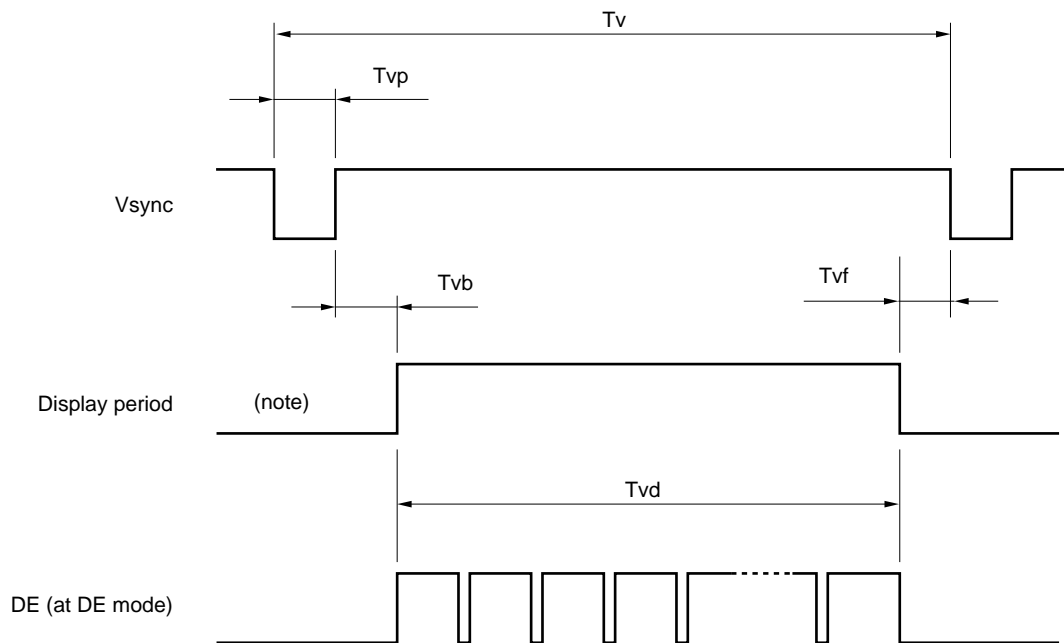

<Horizontal>

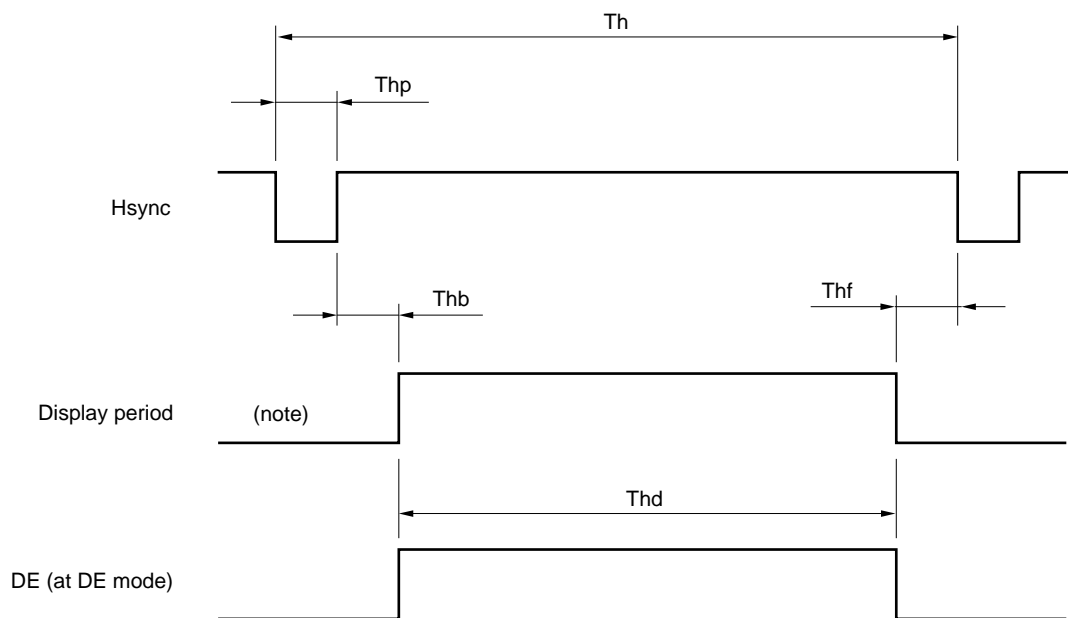

Note These do not exist as signals.

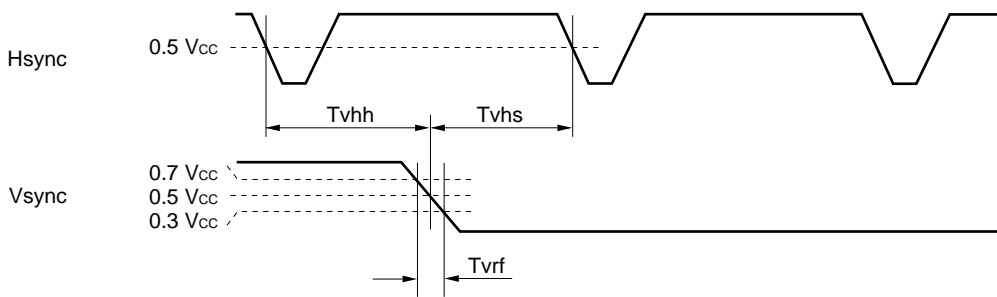
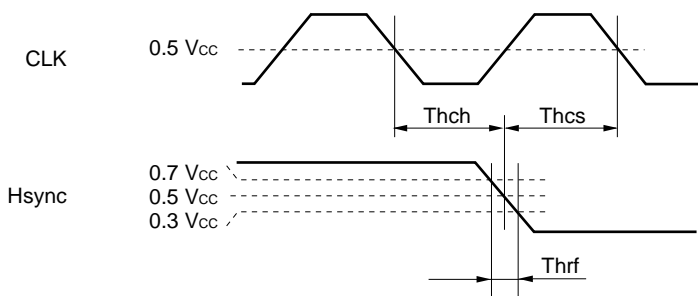
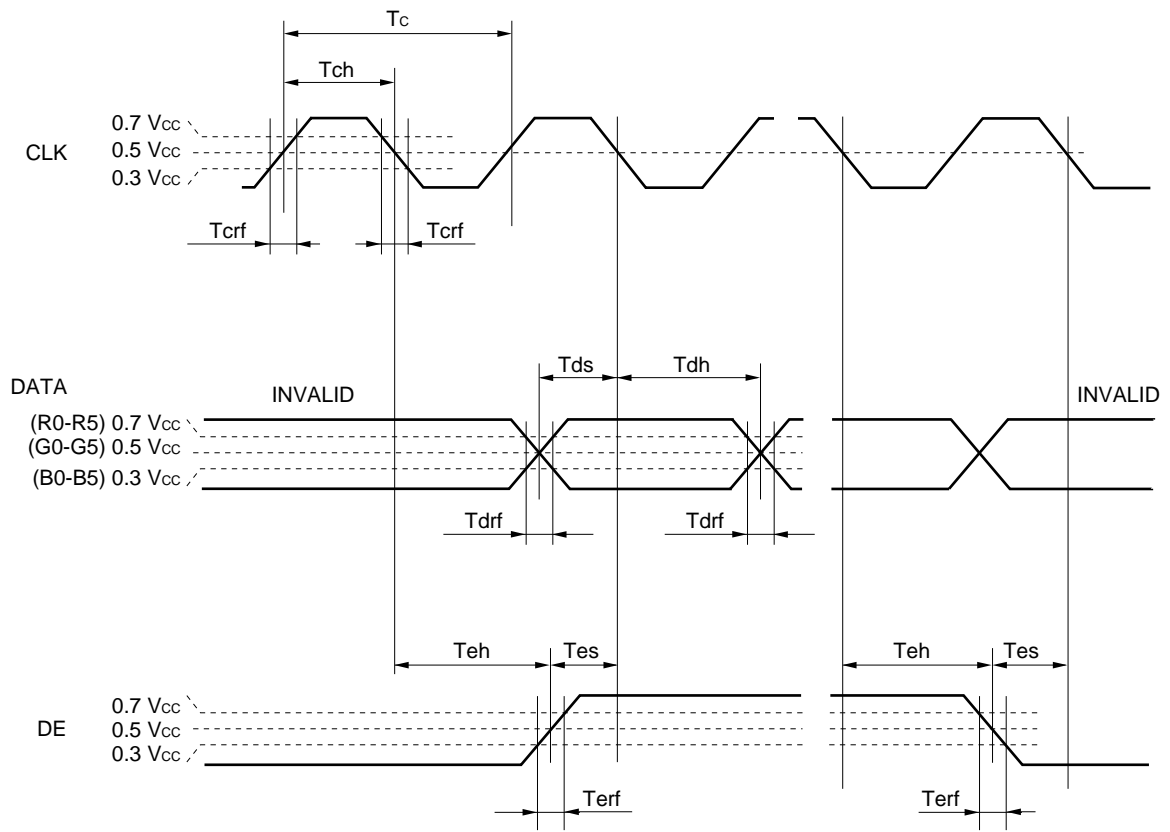

(3) Input signal timing chart

a) Fixed timing mode

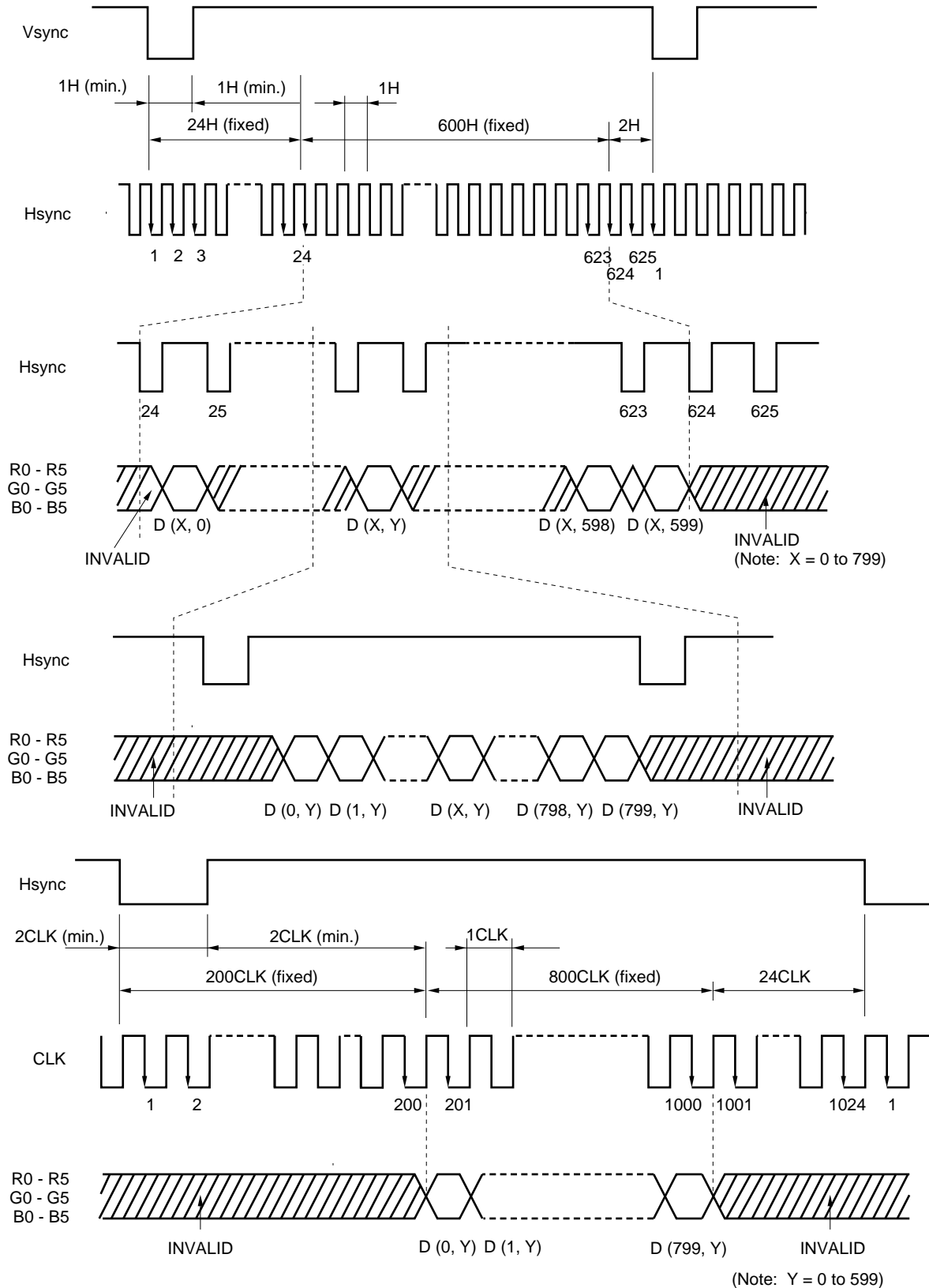

b) DE mode

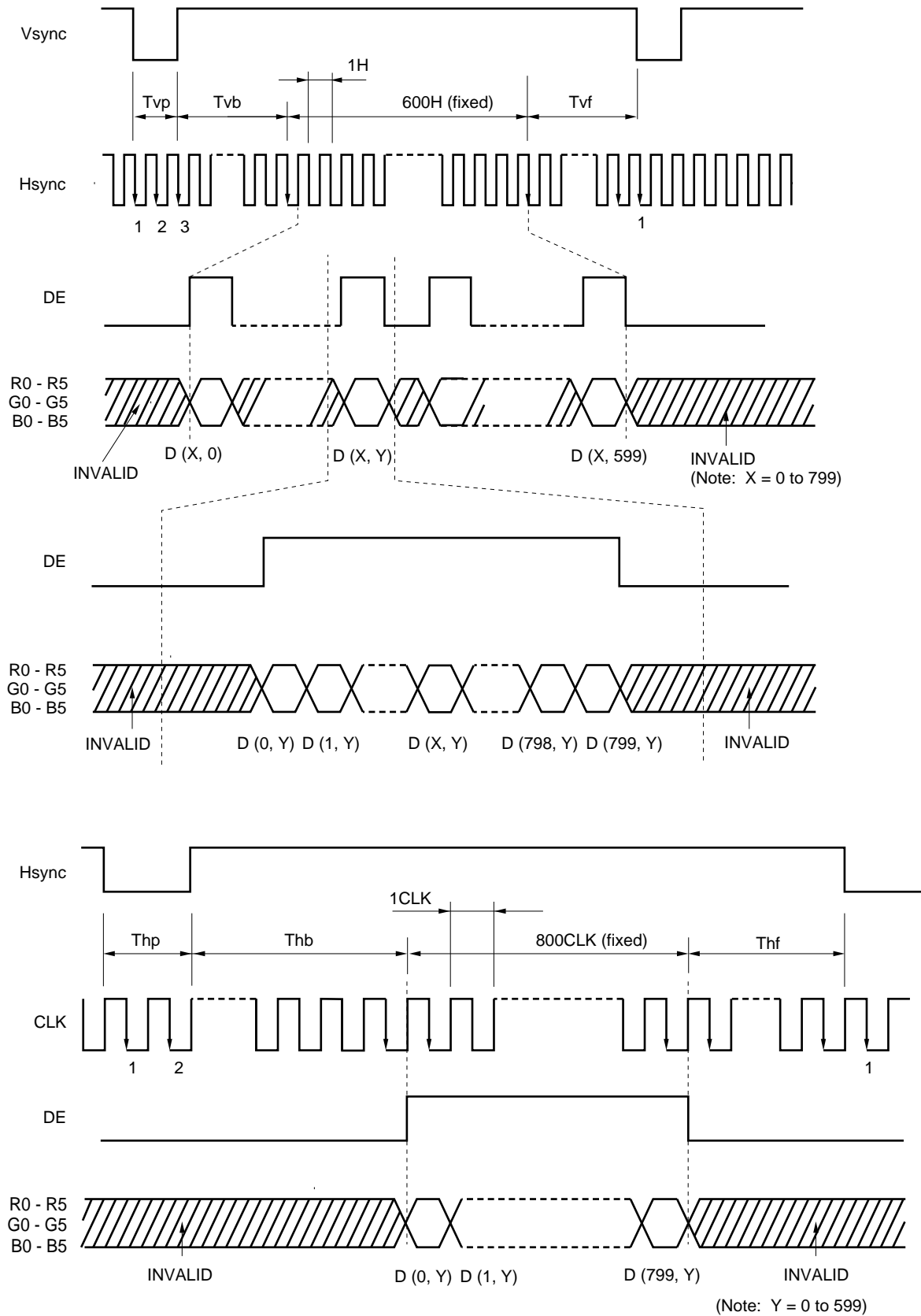

(4) Display position

D (0, 0)	D (1, 0)	-----	D (X, 0)	-----	D (798, 0)	D (799, 0)
D (0, 1)	D (1, 1)	-----	D (X, 1)	-----	D (798, 1)	D (799, 1)
⋮	⋮	-----	⋮	-----	⋮	⋮
D (0, Y)	D (1, Y)	-----	D (X, Y)	-----	D (798, Y)	D (799, Y)
⋮	⋮	-----	⋮	-----	⋮	⋮
D (0, 598)	D (1, 598)	-----	D (X, 598)	-----	D (798, 598)	D (799, 598)
D (0, 599)	D (1, 599)	-----	D (X, 599)	-----	D (798, 599)	D (799, 599)

GENERAL CAUTION

- (1) Caution when taking out the module
 - 1) Pick the pouch only, when taking out module from a shipping package.
- (2) Cautions for handling the module
 - 1) As the electrostatic discharges may break the LCD module, handle the LCD module with care. Peel a protection sheet off from the LCD panel surface as slowly as possible.
 - 2) As the LCD panel and back-light element are made from fragile glass material, impulse and pressure to the LCD module should be avoided.
 - 3) As the surface of polarizer is very soft and easily scratched, use a soft dry cloth without chemicals for cleaning.
 - 4) Do not pull the interface connectors in or out while the LCD module is operating.
 - 5) Put the module display side down on a flat horizontal plane.
 - 6) Handle connectors and cables with care.
- (3) Cautions for the operation
 - 1) When the module is operating, do not lose CILK, Hsync or Vsync signals. If any one of these signals is lost, the LCD panel would be damaged.
 - 2) Obey the supply voltage sequence. If wrong sequence is applied, the module would be damaged.
- (4) Cautions for the atmosphere
 - 1) Dew drop atmosphere should be avoided.
 - 2) Do not store and/or operate the LCD module in a high temperature and/or humidity atmosphere. Storage in an electro-conductive polymer packing pouch and under relatively low temperature atmosphere is recommended.
- (5) Cautions for the module characteristics
 - 1) Do not apply fixed pattern data signal to the LCD module at product aging. Applying fixed pattern for a long time may cause image sticking.
- (6) Other cautions
 - 1) Do not disassemble and/or re-assemble LCD module.
 - 2) Do not re-adjust variable resistor or switch etc.
 - 3) When returning the module for repair or etc., Please pack the module not to be broken.
We recommend to use the original shipping packages.

Liquid Crystal Display has the following specific characteristics. These are not defects or malfunctions. The display condition of LCD module may be affected by the ambient temperature. The LCD module uses cold cathode tubes for backlighting. Optical characteristics, like luminance or uniformity, will change during time. Uneven brightness and/or small spots may be noticed depending on different display patterns.

OUTLINE DRAWING: Rear View (Unit in mm)

