

**TFT COLOR LCD MODULE
NL10276AC30-04**

**38 cm (15.0 inches), 1024 × 768 pixels, 262,144 colors,
Incorporated two-lamp/Edge-light type backlight
Wide viewing angle**

DESCRIPTION

NL10276AC30-04 is a TFT (thin film transistor) active matrix color liquid crystal display (LCD) comprising amorphous silicon TFT attached to each signal electrode, a driving circuit and a backlight. NL10276AC30-04 has a built-in backlight with inverter.

The 38 cm (15.0 inches) diagonal display area contains 1024 × 768 pixels and can display 262,144 colors simultaneously.

FEATURES

- Wide viewing angle (with Retardation Film)
- High luminance
- Low reflection
- LVDS interface (THC63LVDF64A, Thine Electronics, Inc.)
- Incorporated edge type backlight (two lamps inverter) and backlight tube replaceable

APPLICATIONS

- Engineering work station, desk-top type of PC
- Display terminals for control system
- Monitors for process controller



The information in this document is subject to change without notice.

STRUCTURE AND FUNCTIONS

A color TFT (thin film transistor) LCD module is comprised of a TFT liquid crystal panel structure, LSIs for driving the TFT array, and a backlight assembly. The TFT panel structure is created by sandwiching liquid crystal material in the narrow gap between a TFT array glass substrate and a color filter glass substrate. After the driver LSIs are connected to the panel, the backlight assembly is attached to the backside of the panel.

RGB (red, green, blue) data signals from a source system is modulated into a form suitable for active matrix addressing by the onboard signal processor and sent to the driver LSIs which in turn addresses the individual TFT cells.

Acting as an electro-optical switch, each TFT cell regulates light transmission from the backlight assembly when activated by the data source. By regulating the amount of light passing through the array of red, green, and blue dots, color images are created with clarity.

BLOCK DIAGRAM

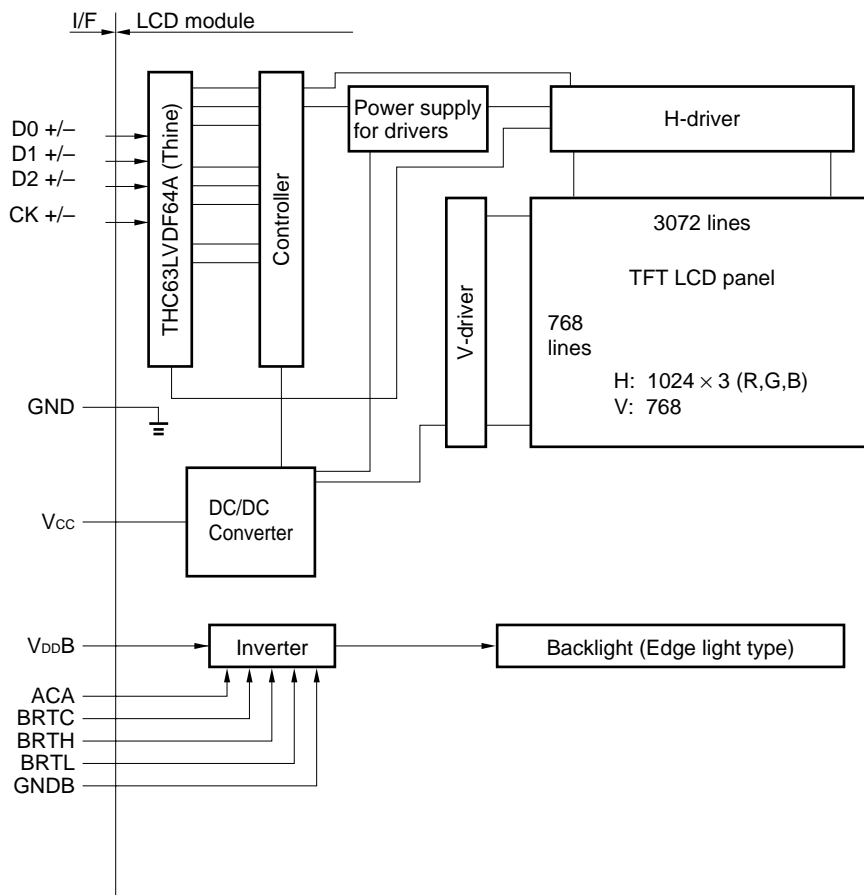

Remark Neither GND nor GNDB is connected to frame.

OUTLINE OF CHARACTERISTICS (at room temperature)

Display area	304.128 (H) × 228.096 (V) mm
Drive system	a-Si TFT active matrix
Display colors	262,144 colors
Number of pixels	1024 × 768 pixels
Pixel arrangement	RGB vertical stripe
Pixel pitch	0.297 (H) × 0.297 (V) mm
Module size	350.0 (H) × 265.0 (V) × 20.0 typ. (D) mm
Weight	1350 g (typ.)
Contrast ratio	400 : 1 (typ., down side 5°)
Viewing angle (more than the contrast ratio of 10 : 1)	<ul style="list-style-type: none"> • Horizontal : 55° (typ., left side, right side) • Vertical : 45° (typ., up side, down side)
Designed viewing direction	<ul style="list-style-type: none"> • Wider viewing angle without image reversal : up side (12 o'clock) • Wider viewing angle with contrast ratio: down side (6 o'clock) • Optimum grayscale (r = 2.2): perpendicular
Polarizer pencil-hardness	3H (min., at JIS K5400)
Color gamut	43 % (typ., at center, to NTSC)
Response time	15 ms (typ.), white to black
Luminance	200 cd/m ² (TYP.)
Signal system	RGB 6-bit signals, Synchronous signals (Hsync, Vsync), Dot clock (CLK) LVDS interface (THC63LVDF64A, Thine Electronics, Inc.)
Supply voltage	5 V (Logic, LCD driving), 12 V (Backlight)
Backlight	Edge light type: Two cold cathode fluorescent lamps with inverter [Replaceable parts] <ul style="list-style-type: none"> • Lamp holder: type No.150 LHS03 • Inverter: type No.150PW031
Power consumption	9.7 W (typ.)

GENERAL SPECIFICATIONS

Item	Specification	Unit
Module size	350.0 ± 0.6 (H) × 265 ± 0.6 (V) × 20.5 max. (D)	mm
Display area	304.128 (H) × 228.096 (V)	mm
Number of pixels	1024 (H) × 768 (V)	pixel
Dot pitch	0.099 (H) × 0.297 (V)	mm
Pixel pitch	0.297 (H) × 0.297 (V)	mm
Pixel arrangement	RGB (Red, Green, Blue) vertical stripe	–
Display colors	262,144 (RGB, 6 bit)	color
Weight	1500 (max.)	g

ABSOLUTE MAXIMUM RATINGS

Parameter	Symbol	Rating	Unit	Remarks
Supply voltage	V _{CC}	–0.3 to +6.0	V	T _a = 25°C
	V _{DD} B	–0.3 to +14	V	
Logic input voltage	V _i	–0.3 to V _{CC} + 0.3	V	
Logic input voltage (backlight-logic signal)	V _i BL1	–0.3 to +5.5	V	
Logic input voltage (backlight-BRTL signal)	V _i BL2	–0.3 to +1.5	V	
Storage temp.	T _{ST}	–20 to +60	°C	
Operating temp.	T _{OP}	0 to +50	°C	Module surface
Humidity (No condensation)	–	≤ 95% relative humidity	–	T _a ≤ 40°C
	–	≤ 85% relative humidity	–	40 < T _a ≤ 50°C
	–	Absolute humidity shall not exceed T _a = 50°C, 85% relative humidity level.	–	T _a > 50°C

ELECTRICAL CHARACTERISTICS

(1) Logic, LCD driving

T_a = 25°C

Parameter	Symbol	MIN.	TYP.	MAX.	Unit	Remarks
Supply voltage	V _{CC}	4.75	5.0	5.25	V	–
Ripple voltage	V _{rp}	–	–	100	mV	for V _{CC}
LVDS signal input “L” voltage	V _{IL}	–100	–	–	mV	VCM = 1.2 V VCM: Common mode voltage in LVDS driver
LVDS signal input “H” voltage	V _{IH}	–	–	+100	mV	
Input voltage	V _i	0	–	2.4	V	–
Terminating resistor	R _t	–	100	–	Ω	–
Supply current	I _{CC}	–	300 Note	600	mA	V _{CC} = 5.0 V

Note Checkered flag pattern (in EIAJ ED-2522)

(2) Backlight

T_a = 25°C

Parameter	Symbol	MIN.	TYP.	MAX.	Unit	Remarks
Supply voltage	V _{DDB}	11.4	12.0	12.6	V	–
Logic input “L” voltage	V _{IL}	0	–	0.8	V	for BRTC, ACA
Logic input “H” voltage	V _{IH}	2.2	–	5.25	V	
Logic input “L” current	I _{IL}	–1.0	–	–	mA	for BRTC, ACA, BRTL
Logic input “H” current	I _{IH}	–	–	0.8	mA	
Supply current	I _{DDB}	–	680	850	mA	V _{DDB} = 12 V (at max. luminance)

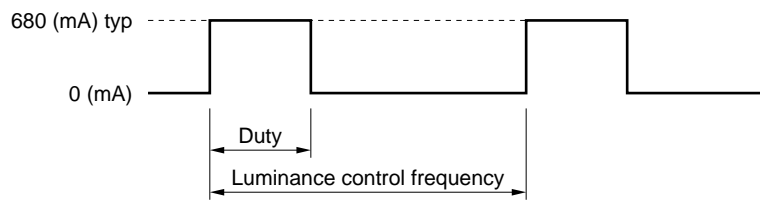

maximum luminance control: 100 %
 minimum luminance control: 20 %
 Luminance control frequency: 243 to 297 Hz 270 Hz (typ.)

SUPPLY VOLTAGE SEQUENCE

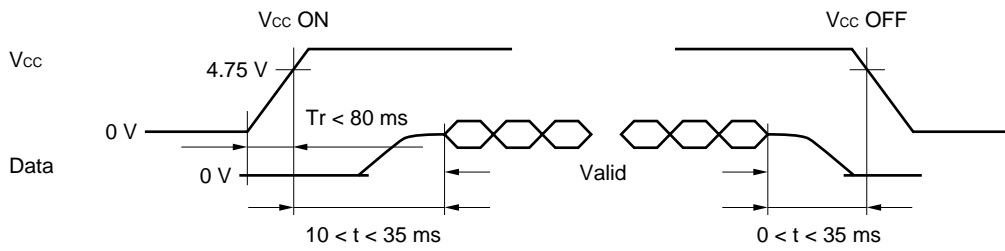

- Notes**
1. Data: pixel data and Pixel clock.
 2. The supply voltage for input signals should be the same as V_{CC}.
 3. Apply V_{DD}B within the LCD operation period. When the backlight turns on before LCD operation or the LCD operation turns off before the backlight turns off, the display may momentarily become white. However, 12 V for backlight should be started up within 80 ms, otherwise, the protection circuit makes the backlight turns off.
 4. When the power is off, please keep whole signals low level or high impedance.

INTERFACE PIN CONNECTION

(1) Interface connector for signal and power

Part No. : FI-SE20P-HF
 Adaptable socket: FI-SE20M
 Supplier : Japan Aviation Electronics Industry Limited (JAE)

CN1

Pin No.	Symbol	Signal type	Function
1	GND	Ground	Note 1
2	GND		
3	NC	Non-connection	-
4	NC		
5	GND	Ground	Note 1
6	CK+	Pixel clock	CLK for pixel data f = 65 MHz (typ.) (LVDS level)
7	CK-		
8	GND	Ground	Note 1
9	D2+	Pixel data	LVDS differential data input
10	D2-		
11	GND	Ground	Note 1
12	D1+	Pixel data	LVDS differential data input
13	D1-		
14	GND	Ground	Note 1
15	D0+	Pixel data	LVDS differential data input
16	D0-		
17	GND	Ground	Note 1
18	GND		
19	V _{cc}	+5.0 V power supply	Supply +5.0 V ±5%
20	V _{cc}		

- Notes**
1. Signal ground for logic and LCD driving. GND should be connected to system ground. Neither GND nor GNDB is connected to frame.
 2. Connect all V_{cc} and GND terminal. Cable use 100 Ω twist pair.
 Connect all pins (except 3,4) to avoid noise issue.
 Use 100 Ω twist pair wires for the cable.

CN1: Figure from socket view

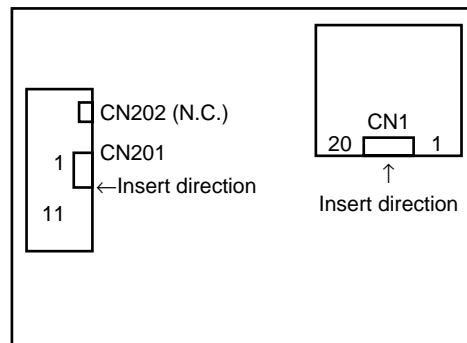
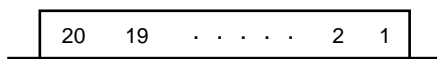

Note CN202 should be opened.

(2) Connector for backlight unit

Part No. : IL-Z-11PL1-SMTY
 Adaptable socket: IL-Z-11S-S125C3
 Supplier : Japan Aviation Electronics Industry Limited (JAE)

CN201

Pin No.	Symbol	Signal type	Function
1	V _{DD} B	12 V power supply	Supply +12 V ±5 %
2	V _{DD} B		
3	V _{DD} B		
4	GNDB	Ground for backlight	Note 1
5	GNDB		
6	GNDB		
7	ACA	Luminance control signal	“H” or “Open”: Normal luminance “L” : Low luminance (1/2 of normal luminance)
8	BRTC	Backlight ON/OFF control signal	“H” or “Open”: Backlight ON “L” : Backlight OFF
9	BRTH	Luminance control signal	Note 2
10	BRTL	Luminance control signal	
11	N.C.		

- Notes** 1. GNDB is not connected to GND or the frame.
 2. There are two ways of controlling luminance.

(1) A way of luminance control by a variable resistor.
 The variable resistor for luminance control should be 10 kΩ type, and zero point of the resistor corresponds to the minimum of luminance.

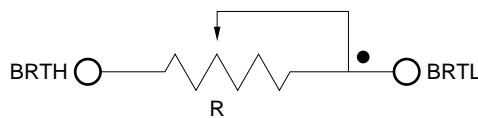

Mating variable resistor : 10 KΩ ±5 %, B curve
 Maximum luminance (100 %) : R = 10 KΩ
 Minimum luminance (30 %) : R = 0 Ω

(2) A way of luminance control by voltage
 BRTH should be fixed to 0 V to control luminance by voltage. The range of input voltage between BRTL and GNDB is as follows.

Maximum luminance (100%, ACA = H): 1 V (typ.)
 Minimum luminance (30%, ACA = H) : 0 V

CN201: Figure from socket view

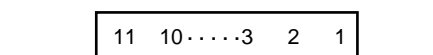

METHOD OF CONNECTION FOR THC63LVDF63A

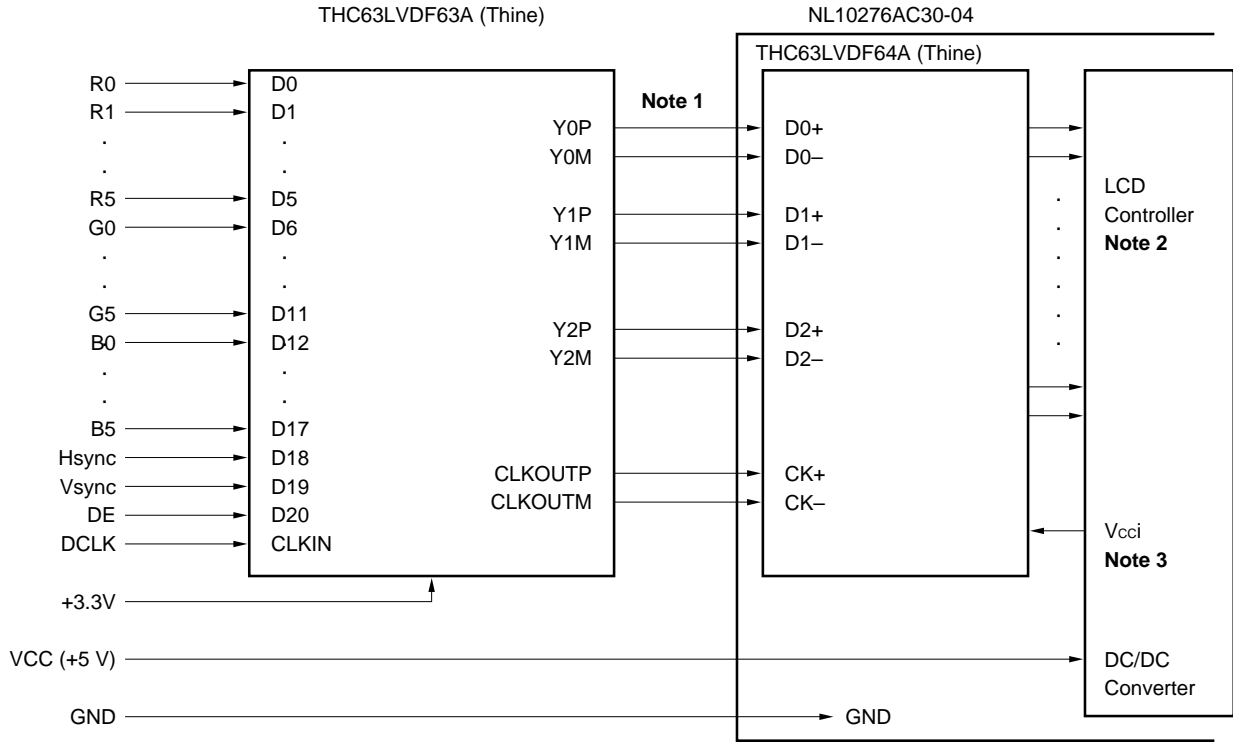

- Notes**
1. 100 Ω twist pair.
 2. These signals should be kept in the specified range of **INPUT SIGNAL TIMING**.
 3. Vcci = 3.3 V (LCD internal voltage)

DISPLAY COLORS vs. INPUT DATA SIGNALS

Display colors		Data signal (0: Low level, 1: High level)																	
		R5	R4	R3	R2	R1	R0	G5	G4	G3	G2	G1	G0	B5	B4	B3	B2	B1	B0
Basic colors	Black	0	0	0	0	0	0	0	0	0	0	0	0	0	0	0	0	0	0
	Blue	0	0	0	0	0	0	0	0	0	0	0	0	1	1	1	1	1	1
	Red	1	1	1	1	1	1	0	0	0	0	0	0	0	0	0	0	0	0
	Magenta	1	1	1	1	1	1	0	0	0	0	0	0	1	1	1	1	1	1
	Green	0	0	0	0	0	0	1	1	1	1	1	1	0	0	0	0	0	0
	Cyan	0	0	0	0	0	0	1	1	1	1	1	1	1	1	1	1	1	1
	Yellow	1	1	1	1	1	1	1	1	1	1	1	1	0	0	0	0	0	0
	White	1	1	1	1	1	1	1	1	1	1	1	1	1	1	1	1	1	1
Red grayscale	Black	0	0	0	0	0	0	0	0	0	0	0	0	0	0	0	0	0	0
		0	0	0	0	0	1	0	0	0	0	0	0	0	0	0	0	0	0
	dark	0	0	0	0	1	0	0	0	0	0	0	0	0	0	0	0	0	0
	↑				↓					↓						↓			
	↓				↑					↑						↑			
	bright	1	1	1	1	0	1	0	0	0	0	0	0	0	0	0	0	0	0
	Red	1	1	1	1	1	0	0	0	0	0	0	0	0	0	0	0	0	0
Green grayscale	Black	0	0	0	0	0	0	0	0	0	0	0	0	0	0	0	0	0	0
		0	0	0	0	0	0	0	0	0	0	1	0	0	0	0	0	0	0
	dark	0	0	0	0	0	0	0	0	0	1	0	0	0	0	0	0	0	0
	↑				↓					↓						↓			
	↓				↑					↑						↑			
	bright	0	0	0	0	0	0	1	1	1	1	0	1	0	0	0	0	0	0
	Green	0	0	0	0	0	0	1	1	1	1	1	1	0	0	0	0	0	0
Blue grayscale	Black	0	0	0	0	0	0	0	0	0	0	0	0	0	0	0	0	0	0
		0	0	0	0	0	0	0	0	0	0	0	0	0	0	0	0	0	1
	dark	0	0	0	0	0	0	0	0	0	0	0	0	0	0	0	0	1	0
	↑				↓					↓						↓			
	↓				↑					↑						↑			
	bright	0	0	0	0	0	0	0	0	0	0	0	0	1	1	1	1	0	1
	Blue	0	0	0	0	0	0	0	0	0	0	0	0	1	1	1	1	1	1

Note Colors are developed in combination with 6-bit signals (64 steps in grayscale) of each primary red, green, and blue color.
 This process can result in up to 262,144 (64 × 64 × 64) colors.

INPUT SIGNAL TIMING

(1) Input signal specifications for LCD controller

Parameter		Symbol	min.	typ.	max.	Unit	Remarks
CLK	Frequency	1/tc	60.0	65.0	68.0	MHz	15.385 ns (typ.)
	Duty	tch/tc	0.4	0.5	0.6	–	Note
	Rise, fall	tcrf	–	–	10	ns	Note
Hsync	Period	th	–	20.676	–	μs	48.363 kHz (typ.)
			–	1344	–	CLK	
	Display period	thd	1024			CLK	
	Front-porch	thf	0	–	–	CLK	–
	Pulse width	thp*	12	–	127	CLK	–
	Back-Porch	thb	2	–	–	CLK	–
	*thp + thb		15	–	160	CLK	–
	CLK-Hsync timing	thh	2	–	–	ns	Note
	Hsync-CLK timing	ths	1	–	–	ns	Note
Rise, fall	thrf	–	–	10	ns	–	
Vsync	Period	tv	–	16.666	–	ms	60.004 Hz (typ.)
			–	806	–	H	
	Display period	tvd	768			H	–
	Front-porch	tvf	1	–	–	H	–
	Pulse width	tvp*	1	3	36	H	–
	Back-porch	tvb*	1	–	36	H	–
	*tpv + tvb		3	–	38	H	–
	Vsync-Hsync timing	tvs	10	–	–	ns	Note
	Hsync-Vsync timing	tvh	1	–	–	CLK	Note
Rise, fall	tvrf	–	–	10	ns	Note	
DATA	DATA-CLK (set up)	tds	1	–	–	ns	Note
	CLK-DATA (Hold)	tdh	2	–	–	ns	Note
DE	DE-CLK timing	tes	1	–	–	ns	–
	CLK-DE timing	teh	2	–	–	ns	
	Rise, fall	terf	–	–	10	ns	

Note These values are in the output of THC63LVDF64A.
 (Refer to **METHOD OF CONNECTION FOR THC63LVDF63A**)

(2) Definition of input signal timing

<Vertical>

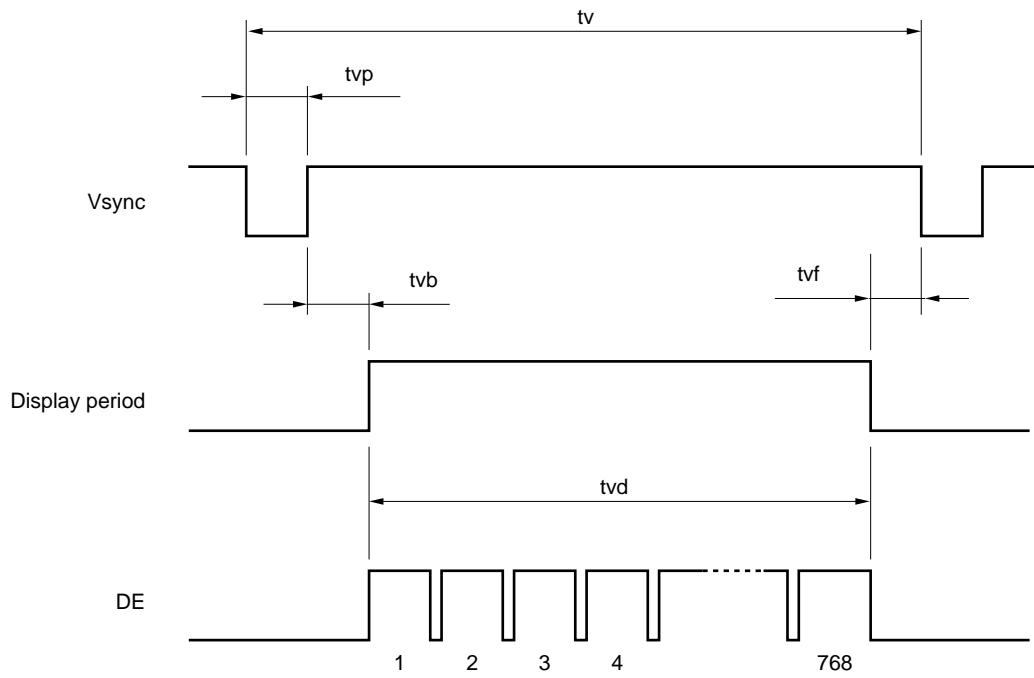

<Horizontal>

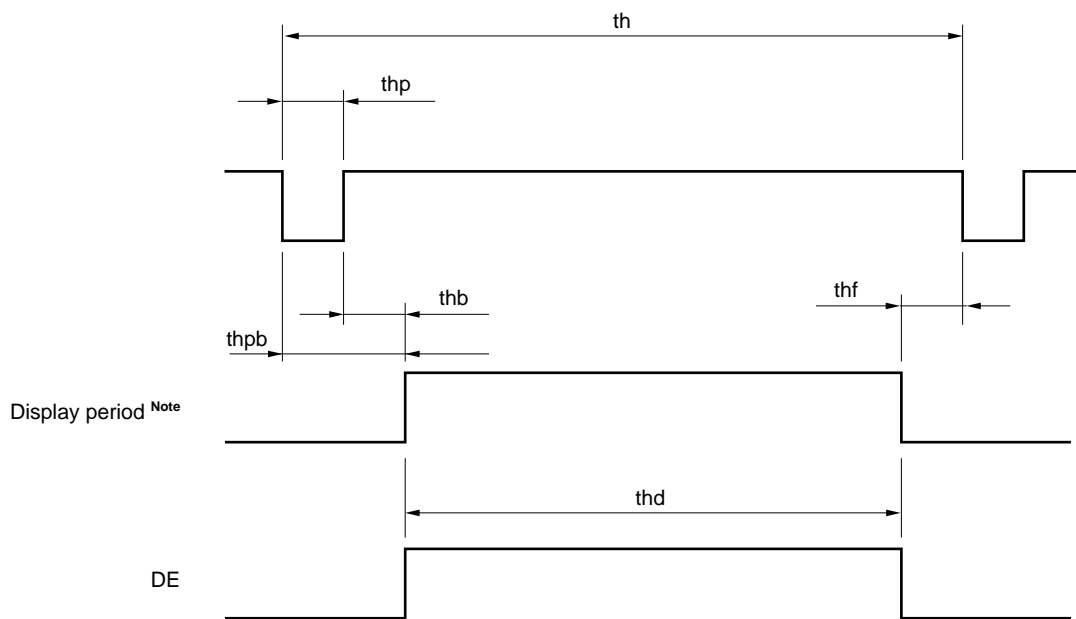

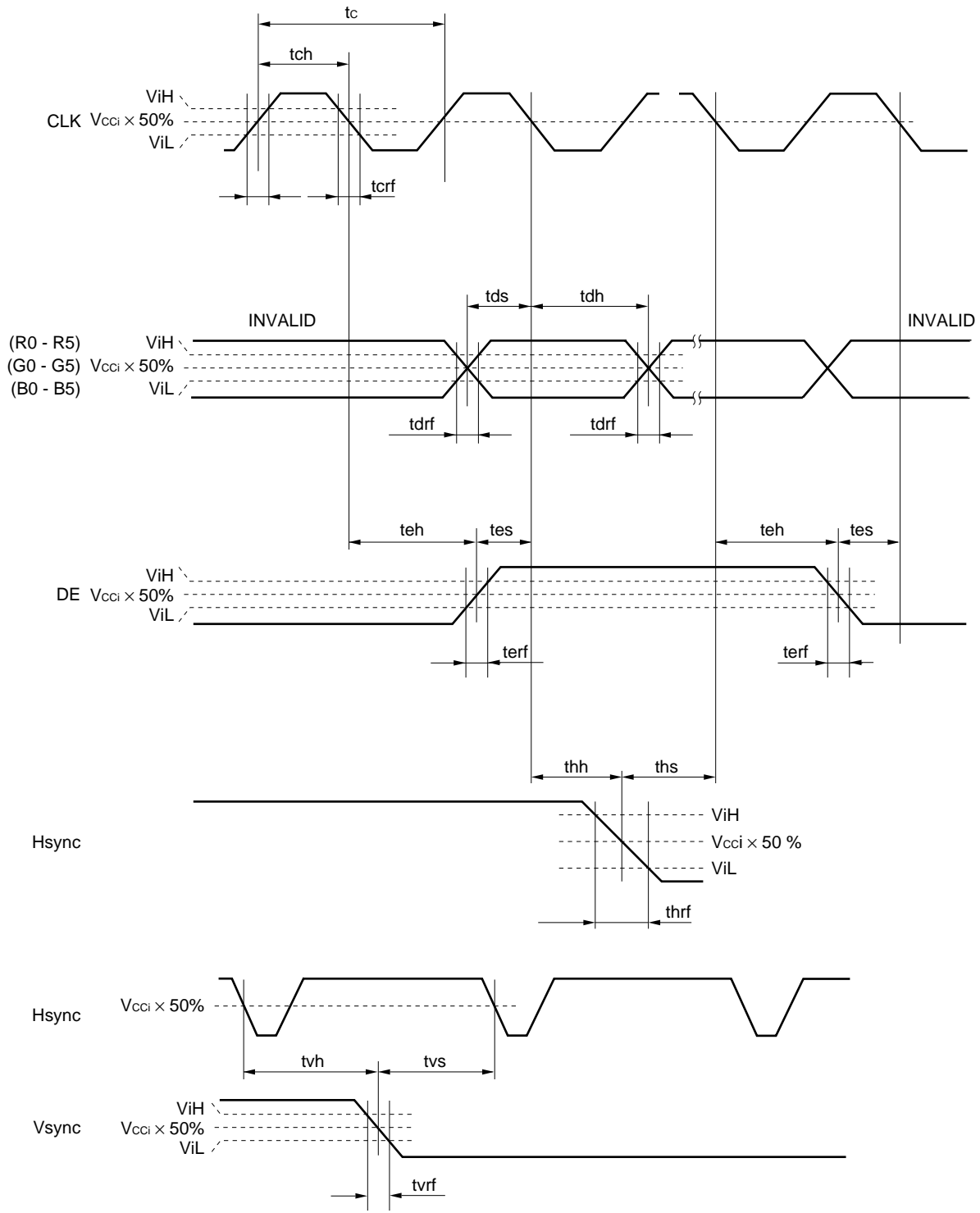

$V_{iH} = V_{cc} \times 0.7$ (min.)
 $V_{iL} = V_{cc} \times 0.3$ (max.)
 $V_{cc} = 3.3$ V (LCD internal voltage)

(3) Input signal timing chart FOR LCD

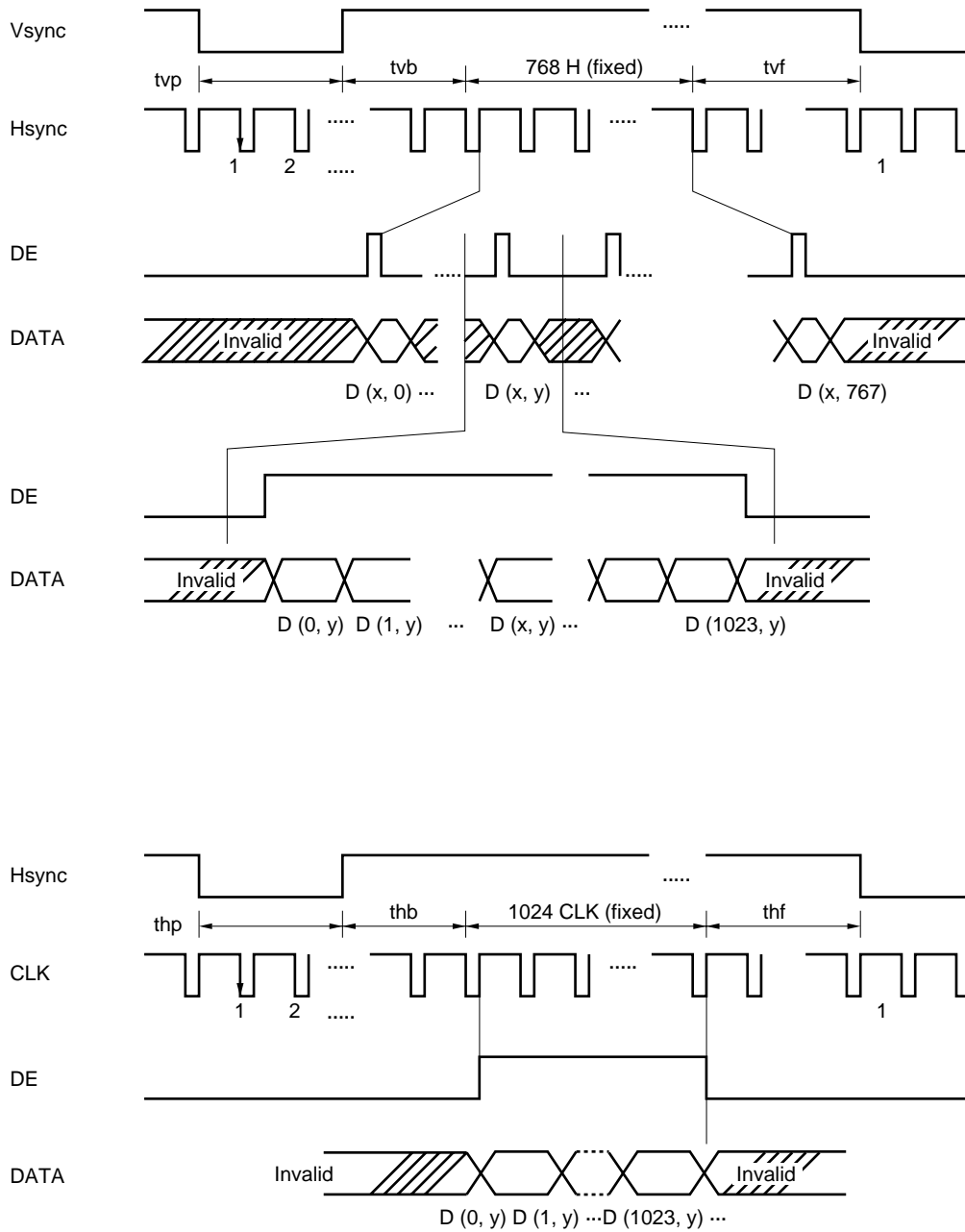

Note These values are in the output of THC63LVDF64A.
 (Refer to **METHOD OF CONNECTION FOR THC63LVDF63A**).

(4) Display position of input data

D (0, 0)	D (1, 0)	---	D (X, 0)	---	D (1022, 0)	D (1023, 0)
D (0, 1)	D (1, 1)	---	D (X, 1)	---	D (1022, 1)	D (1023, 1)
		+-		+-		
D (0, Y)	D (1, Y)	---	D (X, Y)	---	D (1022, Y)	D (1023, Y)
		+-		+-		
D (0, 766)	D (1, 766)	---	D (X, 766)	---	D (1022, 766)	D (1023, 766)
D (0, 767)	D (1, 767)	---	D (X, 767)	---	D (1022, 767)	D (1023, 767)

FOR LVDS RECEIVER

(1) Input signal specifications

Parameter	Symbol	min	typ.	max.	Unit
CLK Frequency	tCK	14.706	15.385	16.667	ns
Bit0 position	tb0	–	0	–	ns
Bit1 position	tb1	–	1/7 tck	–	ns
Bit2 position	tb2	–	2/7 tck	–	ns
Bit3 position	tb3	–	3/7 tck	–	ns
Bit4 position	tb4	–	4/7 tck	–	ns
Bit5 position	tb5	–	5/7 tck	–	ns
Bit6 position	tb6	–	6/7 tck	–	ns
–	SKRM	490	–	–	ps

Note See the specifications of LVDS manufactures for detailed design.

(2) Input signal timing chart

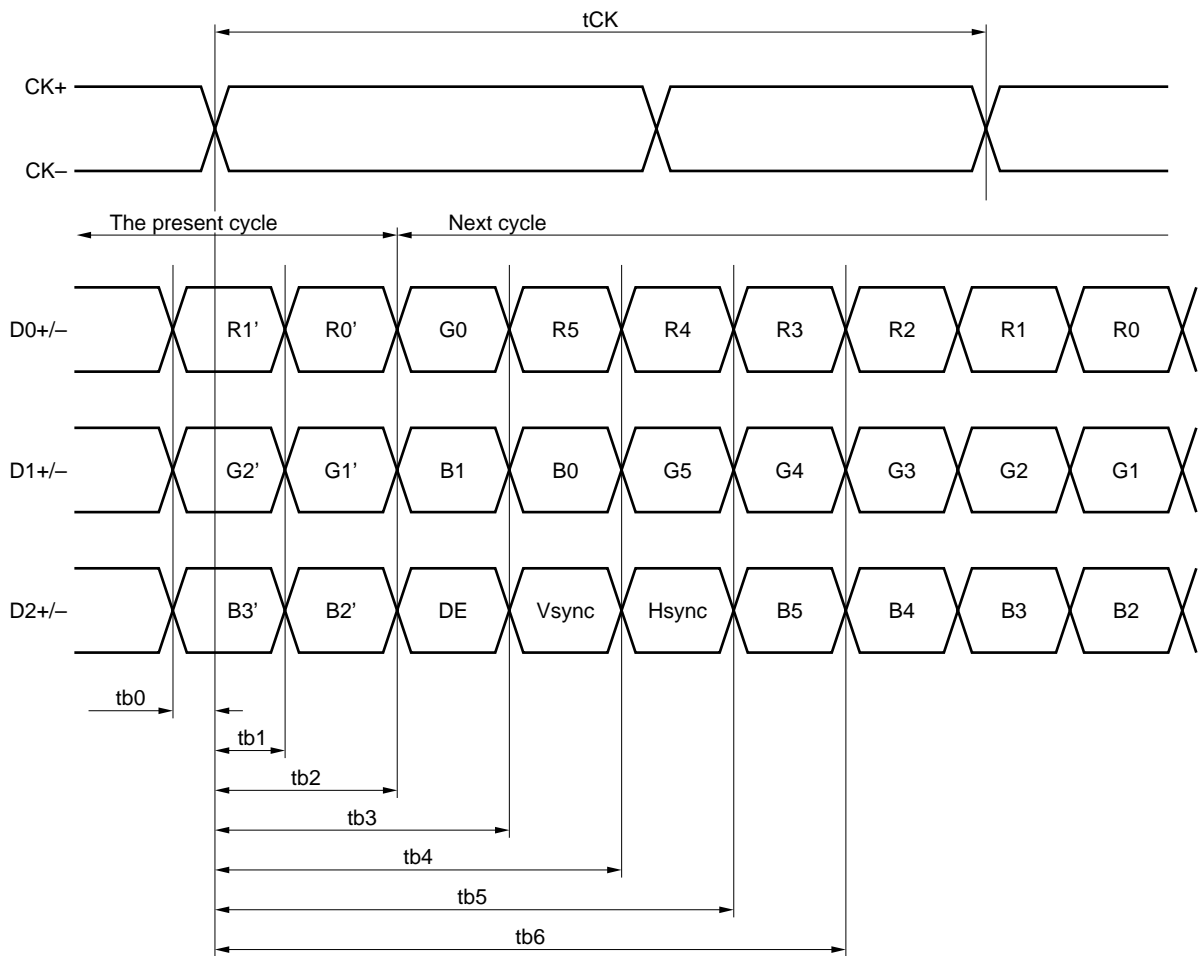

OPTICAL CHARACTERISTICS

($T_a = 25^\circ\text{C}$, $V_{CC} = 5\text{ V}$, $V_{DDB} = 12\text{ V}$)

Parameter	Symbol	Condition	MIN.	TYP.	MAX.	Unit	Remark
Luminance	Lumax	"White"	150	200	–	cd/m ²	Note 1
Contrast ratio	CR	$\theta X = \pm 0^\circ$, $\theta Y = \pm 0^\circ$, at center	80	200	–	–	Note 2
Luminance uniformity	–	Maximum luminance	–	–	1.30	–	Note 3

Reference data

($T_a = 25^\circ\text{C}$, $V_{CC} = 5\text{ V}$, $V_{DDB} = 12\text{ V}$)

Parameter	Symbol	Condition	MIN.	TYP.	MAX.	Unit	Remark	
Contrast ratio	CRP	Best contrast angle, $\theta X = \pm 0^\circ$, $\theta Y = -5^\circ$	–	400	–	–	Note 2	
Viewing angle range	Horizontal	$\theta X+$	CR > 10, $\theta Y = \pm 0^\circ$	50	55	–	deg.	Note 4
		$\theta X-$	CR > 10, $\theta Y = \pm 0^\circ$	50	55	–	deg.	
	Vertical	$\theta Y+$	CR > 10, $\theta X = \pm 0^\circ$	35	45	–	deg.	
		$\theta Y-$	CR > 10, $\theta X = \pm 0^\circ$	30	45	–	deg.	
Color gamut	C	To NTSC	35	43	–	%	–	
Response time	ton	White to black	–	15	40	ms	Note 5	
	toff	Black to white	–	40	50			

Notes 1. The luminance is measured after 20 minutes from the module works, with all pixels in white. Typical value is measured after luminance saturation.

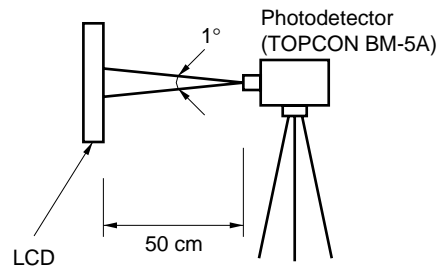

2. The contrast ratio is calculated by using the following formula.

$$\text{Contrast ratio (CR)} = \frac{\text{Luminance with all pixels in white}}{\text{Luminance with all pixels in black}}$$

The Luminance is measured in darkroom.

3. The luminance is measured at near the five points shown below.

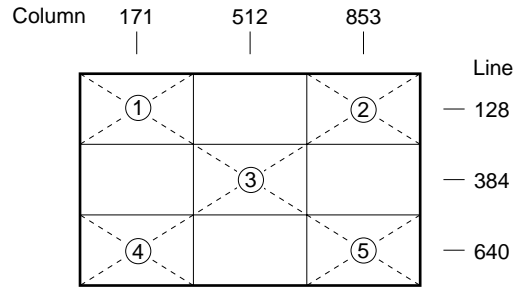

4. Definitions of viewing angle are as follows.

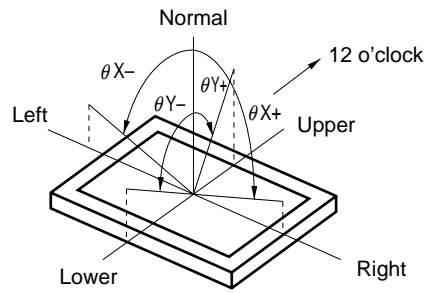

5. Definition of response time is as follows.

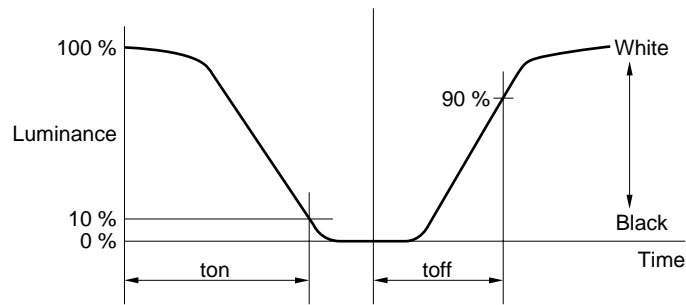

RELIABILITY TEST

Test item	Test condition
High temperature/humidity operation Note 1	50 ± 2°C, 85% relative humidity 240 hours Display data is black.
Heat cycle (operation) Note 1	<1> 0°C ± 3°C ... 1 hour 55°C ± 3°C ... 1 hour <2> 50 cycles, 4 hours/cycle <3> Display data is black.
Thermal shock (non-operation) Note 1	<1> -20°C ± 3°C ... 30 minutes 60°C ± 3°C ... 30 minutes <2> 100 cycles <3> Temperature transition time within 5 minutes
Vibration (non-operation) Notes 1, 2	<1> 5 - 100 Hz, 2G 1 minute/cycle X, Y, Z direction <2> 50 times each direction
Mechanical shock (non-operation) Notes 1, 2	<1> 55 G, 11 ms X, Y, Z direction <2> 3 times each direction
ESD (operation) Notes 1, 3	150 pF, 150 Ω, ±10 kV 9 places on a panel 10 times each place at one-second intervals
Dust (operation) Note 1	15 kinds of dust (JIS Z 8901) Hourly 15 seconds stir, 8 times repeat

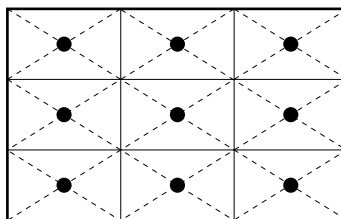

- Notes**
1. Display function is checked by the same condition as LCD module out-going inspection.
 2. Physical damage.
 3. Discharge points “●” are shown in the figure.



GENERAL CAUTIONS

Next figures and sentence are very important. Please understand these contents as follows.

	CAUTION This figure is a mark that you will get hurt and/or the module will have damages when you make a mistake to operate.
---	--

	This figure is a mark that you will get an electric shock when you make a mistake to operate.
	This figure is a mark that you will get hurt when you make a mistake to operate



	Do not touch an inverter, on which is stuck a caution label, while the LCD module is under the operation, because of dangerous high voltage.
---	--

- (1) Caution when taking out the module
 - a) Pick the pouch only, in taking out module from a carrier box.
- (2) Cautions for handling the module
 - a) As the electrostatic discharges may break the LCD module, handle the LCD module with care against electrostatic discharges.
 - b)  As the LCD panel and backlight element are made from fragile glass material, impulse and pressure to the LCD module should be avoided.
 - c) As the surface of polarizer is very soft and easily scratched, use a soft dry cloth without chemicals for cleaning.
 - d) Do not pull the interface connectors in or out while the LCD module is operating.
 - e) Put the module display side down on a flat horizontal plane.
 - f) Handle connectors and cables with care.
 - g) When the module is operating, do not lose CLK, Hsync or Vsync signal. If any one of these signals is lost, the LCD panel would be damaged.
 - h) The torque to mounting screw should never exceed 0.392 N·m (4 kgf·cm).
- (3) Cautions for the atmosphere
 - a) Dew drop atmosphere should be avoided.
 - b) Do not store and/or operate the LCD module in a high temperature and/or high humidity atmosphere. Storage in an anti-static pouch and under the room temperature atmosphere is recommended.
 - c) This module uses cold cathod fluorescent lamp. Therefore, the life time of lamp becomes short if the module is operated under the low temperature environment.
 - d) Do not operate the LCD module in a high magnetic field.

(4) Caution for the module characteristics

- a) Do not apply fixed pattern data signal for a long time to the LCD module. It may cause image sticking. Please use screen savers if the display pattern is fixed more than one hour.
- b) This module has the retardation film which may cause the variation of the color hue in the different viewing angles. The nonuniformity may appear on the screen under the high temperature operation.
- c) The light vertical stripe may be observed depending on the display pattern. This is not defects or malfunctions.
- d) The noise from the inverter circuit may be observed in the luminance control mode. This is not defects or malfunctions.

(5) Other cautions

- a) Do not disassemble and/or reassemble LCD module.
- b) Do not readjust variable resistors or switches in the module.
- c) When returning the module for repair or etc, please pack the module properly to avoid any damages. We recommend using the original shipping packages.
- d) In case that the scan converter is used to convert VGA signal to NTSC, it is recommended using the frame-memory type, not the line-memory.

Liquid Crystal Display has the following specific characteristics. There are not defects or malfunctions.

The optical characteristics of this module may be affected by the ambient temperature.

This module has cold cathode tube for backlight. Optical characteristics, like luminance or uniformity, will be changed by the progress in time.

Uneven brightness and/or small spots may be observed depending on different display patterns.

OUTLINE DRAWING (2/2): Rear View (Unit: mm)

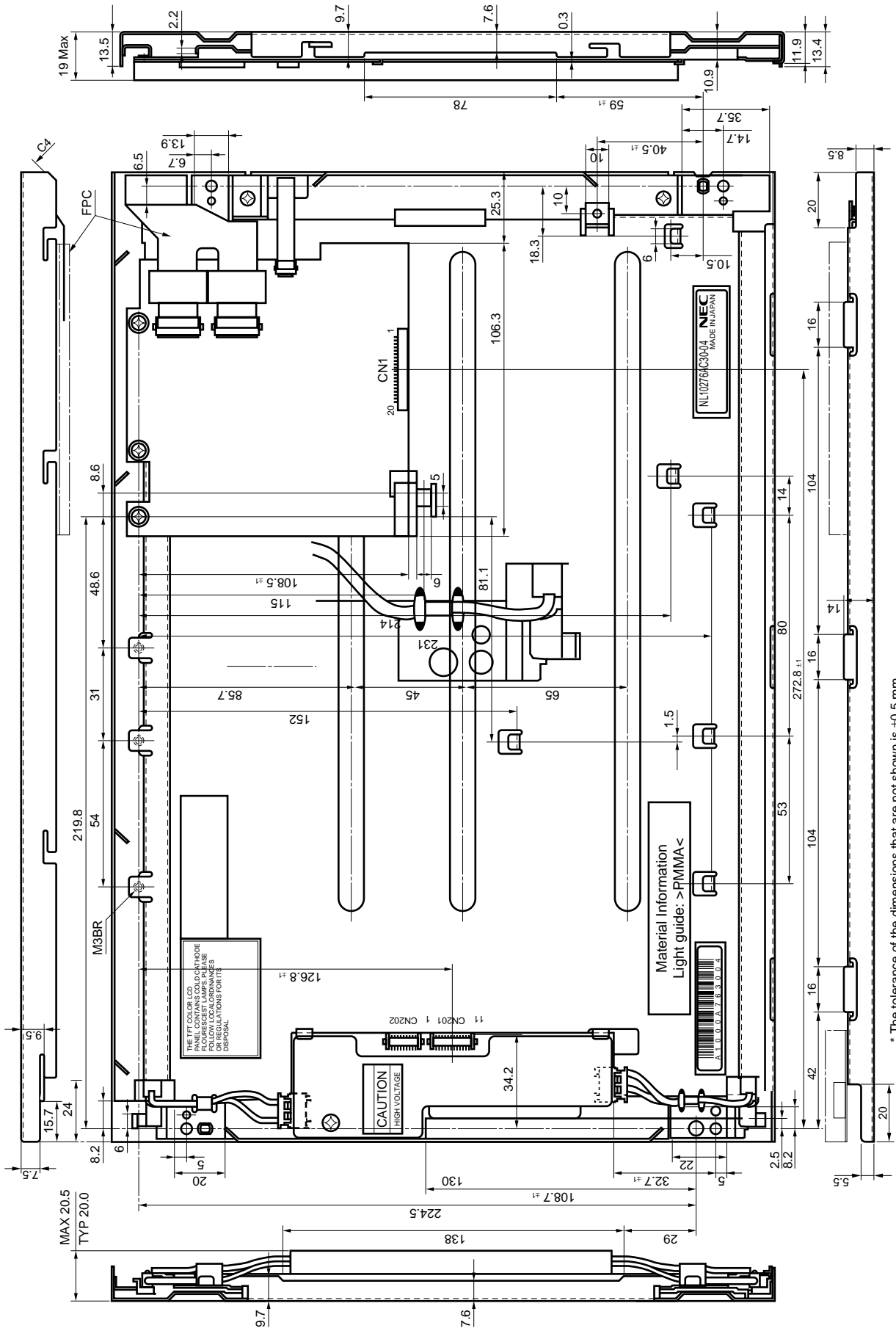

* The tolerance of the dimensions that are not shown is ±0.5 mm.

No part of this document may be copied or reproduced in any form or by any means without the prior written consent of NEC Corporation. NEC Corporation assumes no responsibility for any errors which may appear in this document.

NEC Corporation does not assume any liability for infringement of patents. Copyrights or other intellectual property rights of third parties by or arising from use of a device described herein or any other liability arising from use of such device. No license, either express, implied or otherwise, is granted under any patents, copyrights or other intellectual property rights of NEC Corporation or others.

While NEC Corporation has been making continuous effort to enhance the reliability of its Electronic Components, the possibility of defects cannot be eliminated entirely. To minimize risks of damage or injury to persons or property arising from a defect in an NEC Electronic Components, customers must incorporate sufficient safety measures in its design, such as redundancy, fire-containment, and anti-failure features.

NEC devices are classified into the following three quality grades:

“Standard”, “Special”, and “Specific”. The Specific quality grade applies only to devices developed based on a customer designated “quality assurance program” for a specific application. The recommended applications of a device depend on its quality grade, as indicated below. Customers must check the quality grade of each device before using it in a particular application.

Standard: Computers, office equipment, communications equipment, test and measurement equipment, audio and visual equipment, home electronic appliances, machine tools, personal electronic equipment and industrial robots

Special: Transportation equipment (automobiles, trains, ships, etc.), traffic control systems, anti-disaster systems, anti-crime systems, safety equipment and medical equipment (not specifically designed for life support)

Specific: Aircrafts, aerospace equipment, submersible repeaters, nuclear reactor control systems, life support systems or medical equipment for life support, etc.

The quality grade of NEC devices is “Standard” unless otherwise specified in NEC’s Data Sheets or Data Books. If customers intend to use NEC devices for applications other than those specified for Standard quality grade, they should contact an NEC sales representative in advance.

Anti-radioactive design is not implemented in this product.