



Product Specification

M270HVN02.1

AU OPTRONICS CORPORATION

() Preliminary Specification

(V) Final Specification

Module	27.0" Color TFT-LCD
Model Name	M270HVN02.1

Customer	Date
_____	_____
Approved by	
_____	_____
Note: This Specification is subject to change without notice.	

Approved by	Date
Howard Lee	2013/3/1
Prepared by	
Derec Yang	2013/2/26
Desktop Display Business Group / AU Optronics Corporation	



Product Specification

M270HVN02.1

AU OPTRONICS CORPORATION

Content

1	HANDLING PRECAUTIONS	4
2	GENERAL DESCRIPTION	5
2.1	Display Characteristics	5
2.2	Optical Characteristics	6
3	FUNCTIONAL BLOCK DIAGRAM.....	10
4	ABSOLUTE MAXIMUM RATINGS	11
4.1	TFT LCD Module	11
4.2	Backlight Unit.....	11
4.3	Absolute Ratings of Environment.....	11
5	ELECTRICAL CHARACTERISTICS	13
5.1	TFT LCD Module	13
5.1.1	Power Specification	13
5.1.2	Signal Electrical Characteristics	15
5.2	Backlight Unit.....	17
6	SIGNAL CHARACTERISTICS	18
6.1	Pixel Format Definition	18
6.2	Input Data Format Definition	18
6.3	Signal Description.....	19
6.4	Timing Characteristics.....	21
6.5	Timing Diagram	22
6.6	Power ON/OFF Sequence	23
7	CONNECTOR AND PIN ASSIGNMENT.....	24
7.1	TFT LCD Module	24
7.1.1	Pin Assignment.....	24
7.2	LED Connector on Backlight Unit.....	25
7.2.1	LED Pin assignment	25
7.2.2	LED Connector Dimension	26
7.2.3	LED Mating housing dimension.....	26
8	RELIABILITY TEST.....	27
9	SHIPPING LABEL.....	28
10	MECHANICAL CHARACTERISTICS	29
11	PACKING SPECIFICATION	32
11.1	Packing Flow	32
11-2	Pallet and shipment information	33



Product Specification

M270HVN02.1

AU OPTRONICS CORPORATION

Records of Revision

Version and Date	Page	Old description	New Description	Remark																																																								
0.1 2012/10/18		First Version																																																										
0.2 2012/11/9	17	LED Forward Current 120mA	Update LED Forward current as 110mA																																																									
1.0 final 2012/12/06	17		Re-define the LED symbol name																																																									
	19/20/24	<table border="1"> <thead> <tr> <th>Pin#</th> <th>Signal Name</th> <th>Pin#</th> <th>Signal Name</th> </tr> </thead> <tbody> <tr> <td>1</td> <td>RxOIN0</td> <td>2</td> <td>RxOIN0+</td> </tr> <tr> <td>3</td> <td>RxOIN1-</td> <td>4</td> <td>RxOIN1+</td> </tr> <tr> <td>5</td> <td>RxOIN2-</td> <td>6</td> <td>RxOIN2+</td> </tr> <tr> <td>7</td> <td>GND</td> <td>9</td> <td>RxOCLKIN-</td> </tr> <tr> <td>8</td> <td>RxOCLKIN+</td> <td>10</td> <td>RxOINS-</td> </tr> <tr> <td>11</td> <td>RxOIN3+</td> <td>12</td> <td>RxEIN0</td> </tr> </tbody> </table>	Pin#	Signal Name	Pin#	Signal Name	1	RxOIN0	2	RxOIN0+	3	RxOIN1-	4	RxOIN1+	5	RxOIN2-	6	RxOIN2+	7	GND	9	RxOCLKIN-	8	RxOCLKIN+	10	RxOINS-	11	RxOIN3+	12	RxEIN0	<table border="1"> <thead> <tr> <th>Pin#</th> <th>Signal Name</th> <th>Pin#</th> <th>Signal Name</th> </tr> </thead> <tbody> <tr> <td>1</td> <td>RxO0-</td> <td>2</td> <td>RxO0+</td> </tr> <tr> <td>3</td> <td>RxO1-</td> <td>4</td> <td>RxO1+</td> </tr> <tr> <td>5</td> <td>RxO2-</td> <td>6</td> <td>RxO2+</td> </tr> <tr> <td>7</td> <td>GND</td> <td>8</td> <td>RxOCLK-</td> </tr> <tr> <td>9</td> <td>RxOCLK+</td> <td>10</td> <td>RxO3-</td> </tr> <tr> <td>11</td> <td>RxO3+</td> <td>12</td> <td>RxE0-</td> </tr> </tbody> </table>	Pin#	Signal Name	Pin#	Signal Name	1	RxO0-	2	RxO0+	3	RxO1-	4	RxO1+	5	RxO2-	6	RxO2+	7	GND	8	RxOCLK-	9	RxOCLK+	10	RxO3-	11	RxO3+	12	RxE0-	Re-named the LVDS Signal
Pin#	Signal Name	Pin#	Signal Name																																																									
1	RxOIN0	2	RxOIN0+																																																									
3	RxOIN1-	4	RxOIN1+																																																									
5	RxOIN2-	6	RxOIN2+																																																									
7	GND	9	RxOCLKIN-																																																									
8	RxOCLKIN+	10	RxOINS-																																																									
11	RxOIN3+	12	RxEIN0																																																									
Pin#	Signal Name	Pin#	Signal Name																																																									
1	RxO0-	2	RxO0+																																																									
3	RxO1-	4	RxO1+																																																									
5	RxO2-	6	RxO2+																																																									
7	GND	8	RxOCLK-																																																									
9	RxOCLK+	10	RxO3-																																																									
11	RxO3+	12	RxE0-																																																									
	33		Fulfill Pallet and shipment information																																																									
1.1 2012/12/25	24		New add Connector STARCONN																																																									
	11/17/25	<p>Old naming</p> <table border="1"> <thead> <tr> <th>Symbol</th> <th>Description</th> </tr> </thead> <tbody> <tr> <td>IRLED1</td> <td rowspan="4">LED Forward Current</td> </tr> <tr> <td>IRLED2</td> </tr> <tr> <td>IRLED3</td> </tr> <tr> <td>IRLED4</td> </tr> <tr> <td>VLB</td> <td>Light Bar Operation Voltage (for reference)</td> </tr> </tbody> </table>	Symbol	Description	IRLED1	LED Forward Current	IRLED2	IRLED3	IRLED4	VLB	Light Bar Operation Voltage (for reference)	<p>New naming :</p> <table border="1"> <thead> <tr> <th>Symbol</th> <th>Description</th> </tr> </thead> <tbody> <tr> <td>IFLED1</td> <td rowspan="4">LED Forward Current</td> </tr> <tr> <td>IFLED2</td> </tr> <tr> <td>IFLED3</td> </tr> <tr> <td>IFLED4</td> </tr> <tr> <td>VSLED</td> <td>Light Bar Operation Voltage (for reference)</td> </tr> </tbody> </table>	Symbol	Description	IFLED1	LED Forward Current	IFLED2	IFLED3	IFLED4	VSLED	Light Bar Operation Voltage (for reference)																																							
Symbol	Description																																																											
IRLED1	LED Forward Current																																																											
IRLED2																																																												
IRLED3																																																												
IRLED4																																																												
VLB	Light Bar Operation Voltage (for reference)																																																											
Symbol	Description																																																											
IFLED1	LED Forward Current																																																											
IFLED2																																																												
IFLED3																																																												
IFLED4																																																												
VSLED	Light Bar Operation Voltage (for reference)																																																											
1.2 2013/1/14	5/33		Modify the physical size as below 630(H)x368.2(V)x10.0(D) (Typ.)																																																									
1.3 2013/2/26	29/30		To modify the label position																																																									
	6		To define the maximum value of response time																																																									



Product Specification

M270HVN02.1

AU OPTRONICS CORPORATION

1 Handling Precautions

- 1) Since front polarizer is easily damaged, pay attention not to scratch it.
- 2) Be sure to turn off power supply when inserting or disconnecting from input connector.
- 3) Wipe off water drop immediately. Long contact with water may cause discoloration or spots.
- 4) When the panel surface is soiled, wipe it with absorbent cotton or other soft cloth.
- 5) Since the panel is made of glass, it may break or crack if dropped or bumped on hard surface.
- 6) Since CMOS LSI is used in this module, take care of static electricity and insure human earth when handling.
- 7) Do not open or modify the Module Assembly.
- 8) Do not press the reflector sheet at the back of the module to any directions.
- 9) In case if a Module has to be put back into the packing container slot after once it was taken out from the container, do not press the center of LED light bar edge. Instead, press at the far ends of the LED light bar edge softly. Otherwise the TFT Module may be damaged.
- 10) At the insertion or removal of the Signal Interface Connector, be sure not to rotate nor tilt the Interface Connector of the TFT Module.
- 11) After installation of the TFT Module into an enclosure, do not twist nor bend the TFT Module even momentary. At designing the enclosure, it should be taken into consideration that no bending/twisting forces are applied to the TFT Module from outside. Otherwise the TFT Module may be damaged.
- 12) Small amount of materials having no flammability grade is used in the LCD module. The LCD module should be supplied by power complied with requirements of Limited Power Source (IEC60950 or UL1950), or be applied exemption.
- 13) Avoid touching COF position while doing mechanical design.
- 14) While storing modules as spares for a long time, the following precautions are necessary:
 - Store modules in a dark place. Do not expose them to sunlight or fluorescent light.
 - Keep the temperature between 5°C and 35°C at normal humidity.



Product Specification

M270HVN02.1

AU OPTRONICS CORPORATION

2 General Description

This specification applies to the 27 inch-FHD color a-Si TFT-LCD Module M270HVN02.1 The display supports the FHD - 1920(H) x 1080(V) screen format and 16.7M colors (RGB 8-bit data). The light source of this TFT-LCD module is W-LED. All input signals are 2-channel LVDS interface and this module doesn't contain a driver for backlight.

2.1 Display Characteristics

The following items are characteristics summary on the table under 25°C condition:

Items	Unit	Specification
Screen Diagonal	[mm]	685.65(27.0")
Active Area	[mm]	597.6 (H) x 336.15 (V)
Pixels H x V		1920(x3) x 1080
Pixel Pitch	[um]	311.25 (per one triad) ×311.25
Pixel Arrangement		R.G.B. Vertical island
Display Mode		VA Mode, Normally Black
White Luminance (Center)	[cd/m ²]	300 cd/m ² (Typ.)
Contrast Ratio		3000 (Typ.)
Optical Response Time	[msec]	12ms (Typ., on/off)
Nominal Input Voltage VDD	[Volt]	5 V (Typ)
Power Consumption (VDD line + LED line)	[Watt]	26.88 watt VDD line : PDD (typ), All white pattern at 60Hz = 5.1 W LED line : PBLU (typ) = 21.78 W@110mA
Weight	[g]	2300 gram (Typ.)
Physical Size	[mm]	630(H)x368.2(V)x10.0(D) (Typ.)
Electrical Interface		Dual channel LVDS
Support Color		16.7M colors (RGB 8-bit)
Surface Treatment		Anti-Glare 3H
Temperature Range		
Operating	[°C]	0 to +50
Storage (Shipping)	[°C]	-20 to +60
RoHS Compliance		RoHS Compliance
TCO Compliance		TCO 6.0 Compliance



Product Specification

M270HVN02.1

AU OPTRONICS CORPORATION

2.2 Optical Characteristics

The optical characteristics are measured under stable conditions at 25°C:

Item	Unit	Conditions	Min.	Typ.	Max.	Note
Viewing Angle	[degree]	Horizontal (Right) CR = 10 (Left)	150	178	- -	2
		Vertical (Up) CR = 10 (Down)	150	178	- -	
Contrast ratio		Normal Direction	1800	3000	-	3
Response Time	[msec]	Raising Time (T_{rR})	-	7	17	4
		Falling Time (T_{rF})	-	5	7	
		Raising + Falling	-	12	24	
Color / Chromaticity Coordinates (CIE)		Red x	0.615	0.645	0.675	5
		Red y	0.300	0.330	0.360	
		Green x	0.285	0.315	0.345	
		Green y	0.590	0.620	0.650	
		Blue x	0.125	0.154	0.184	
		Blue y	0.034	0.064	0.094	
Color Coordinates (CIE) White		White x	0.283	0.313	0.343	
		White y	0.299	0.329	0.359	
Central Luminance	[cd/m^2]		240	300	-	6
Luminance Uniformity	[%]		75	80	-	7
Crosstalk (in 60Hz)	[%]				1.5	8
Flicker	dB				-20	9



Product Specification

M270HVN02.1

AU OPTRONICS CORPORATION

Note 1: Measurement Method

The LCD module should be stabilized at given temperature for 30 minutes to avoid abrupt temperature change during measuring (at surface 35°C). In order to stabilize the luminance, the measurement should be executed after lighting Backlight for 30 minutes in a stable, windless and dark room.

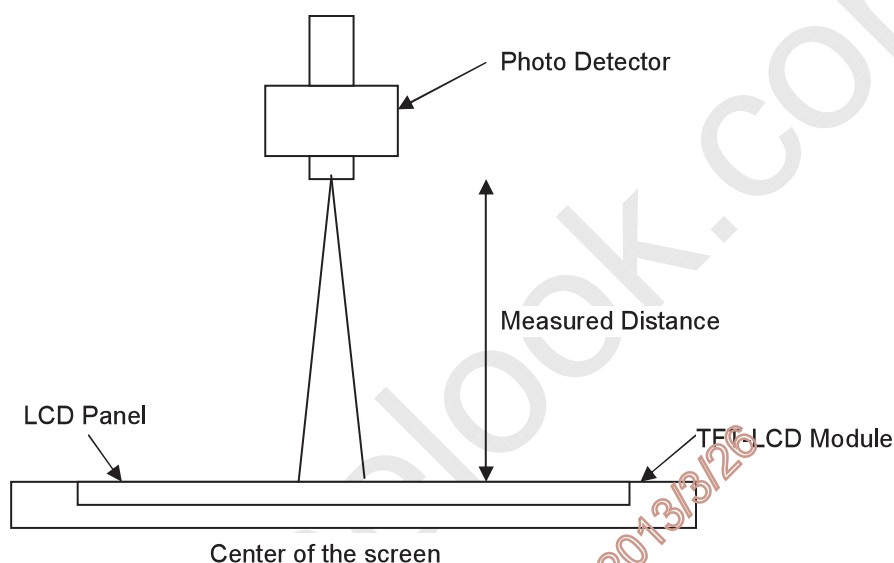

Note 2: Definition of Viewing Angle measured by ELDIM (E2C Contrast 88)

Viewing angle is the measurement of contrast ratio ≥ 10 , at the screen center, over a 180° horizontal and 180° vertical range (off-normal viewing angles). The 180° viewing angle range is broken down as follows; 90° (θ) horizontal left and right and 90° (ϕ) vertical, high (up) and low (down). The measurement direction is typically perpendicular to the display surface with the screen rotated about its center to develop the desired measurement viewing angle.

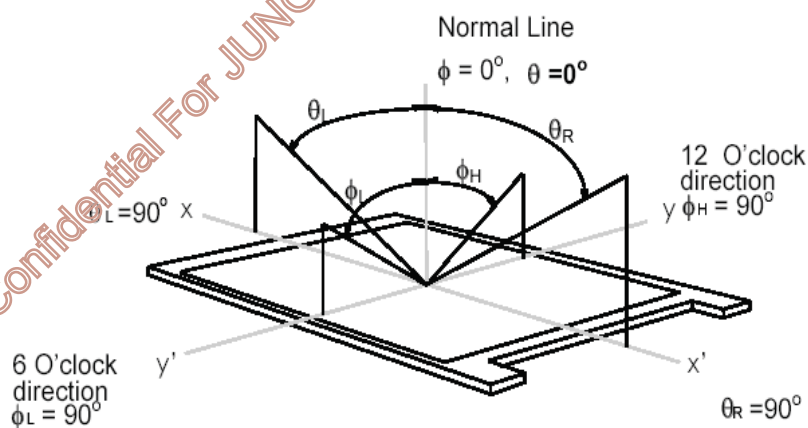



Product Specification

M270HVN02.1

AU OPTRONICS CORPORATION

Note 3: Contrast Ratio measured by TOPCON SR-3

Note 4: Definition of Response time measured by Westar TRD-100A

The output signals of photo detector are measured when the input signals are changed from "Full Black" to "Full White" (rising time, T_{rR}), and from "Full White" to "Full Black" (falling time, T_{rF}), respectively. The response time is interval between the 10% and 90% (1 frame at 60 Hz) of amplitudes.

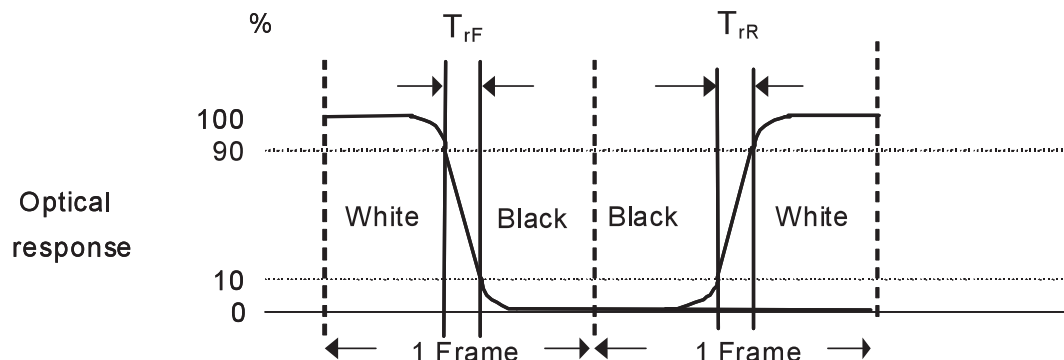

$T_{rR} + T_{rF} = 12 \text{ msec (typ.)}$.

Note 5: Color Chromaticity and Coordinates (CIE) measured by TOPCON SR-3

Note 6: Central Luminance measured by TOPCON SR-3

Note 7: Luminance Uniformity of these 9 points defined as below and measured by TOPCON SR-3

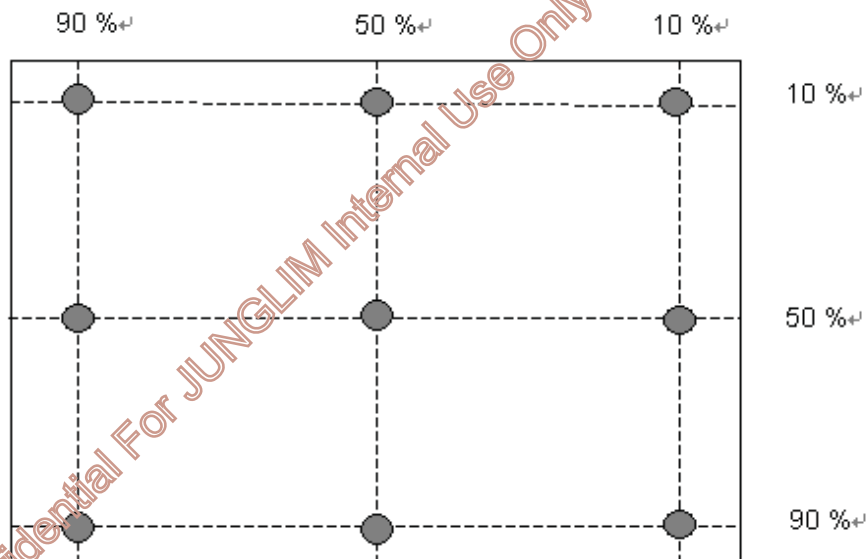

$$\text{Uniformity} = \frac{\text{Minimum Luminance in 9 points (1-9)}}{\text{Maximum Luminance in 9 Points (1-9)}}$$

Note 8: Crosstalk defined as below and measured by TOPCON SR-3



Product Specification

M270HVN02.1

AU OPTRONICS CORPORATION

$$CT = | YB - YA | / YA \times 100 (\%)$$

Where

YA = Luminance of measured location without gray level 0 pattern (cd/m2)

YB = Luminance of measured location with gray level 0 pattern (cd/m2)

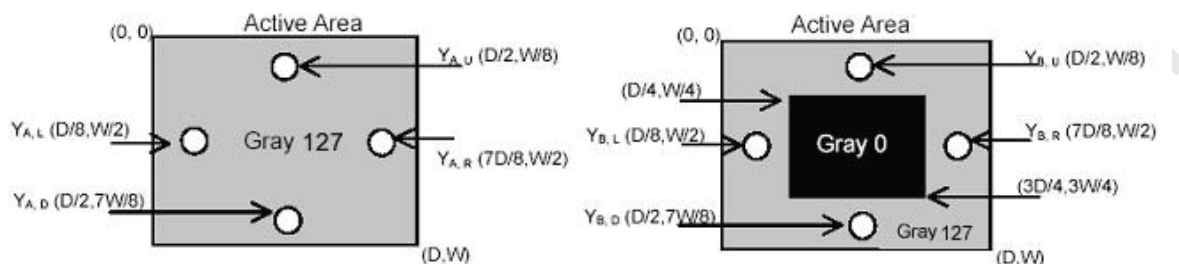

Note 9: Test Pattern Sub-checker Pattern measured by TOPCON SR-3

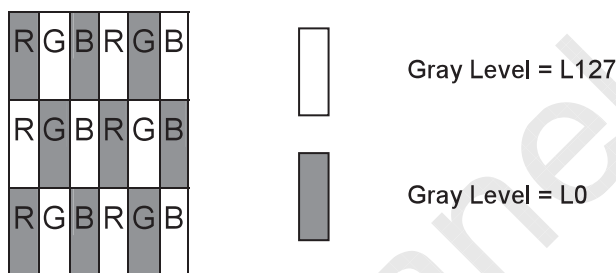

Method: Record dBV & DC value with TRD-100

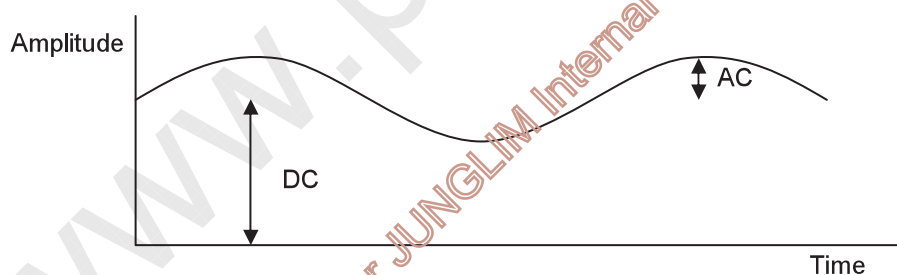

$$\text{Flicker (dB)} = 20 \log \frac{\text{AC Level (at 30 Hz)}}{\text{DC Level}}$$



Product Specification

M270HVN02.1

AU OPTRONICS CORPORATION

3 Functional Block Diagram

The following diagram shows the functional block of the 27.0 inch Color TFT-LCD Module:

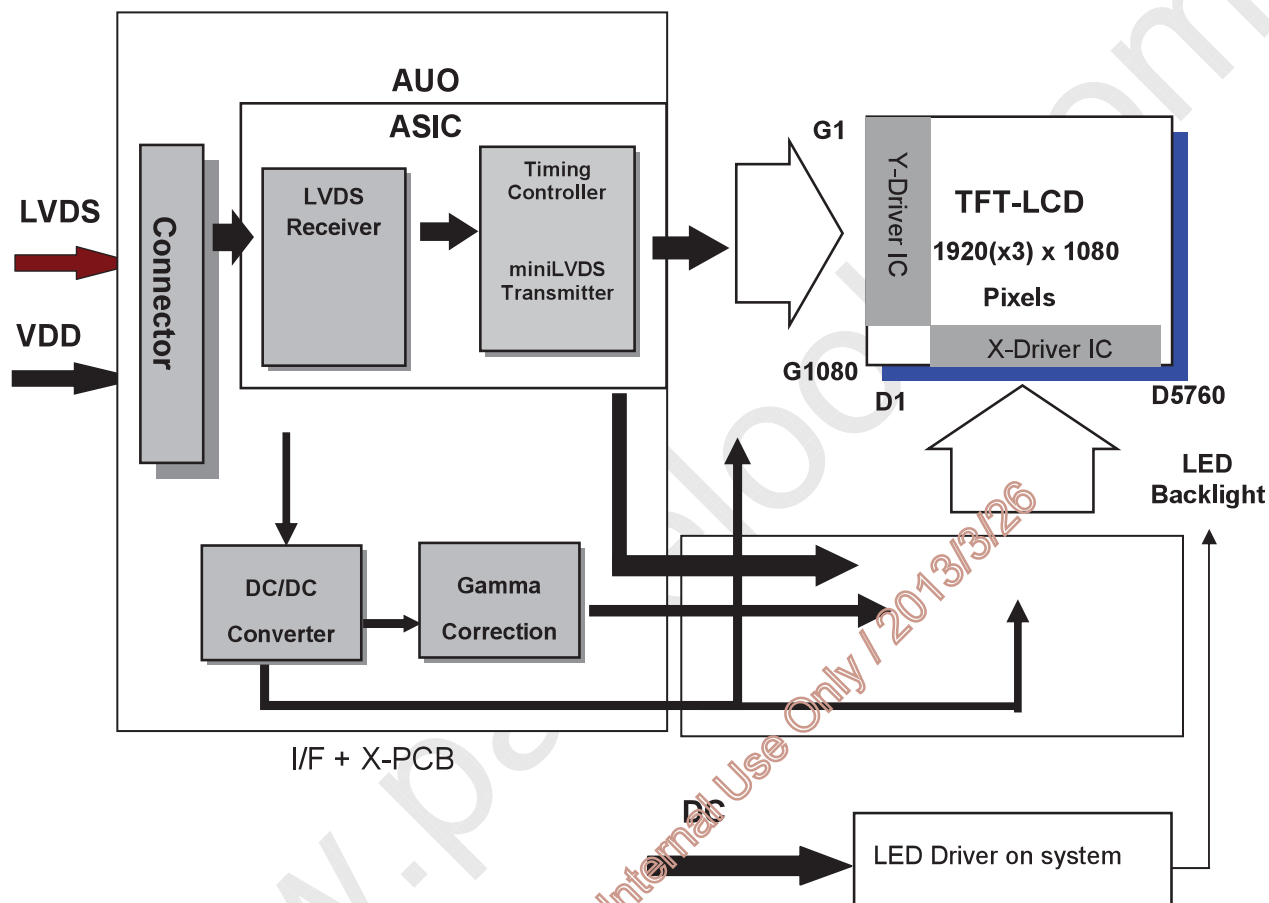



Product Specification

M270HVN02.1

AU OPTRONICS CORPORATION

4 Absolute Maximum Ratings

Absolute maximum ratings of the module are listed as follows:

4.1 TFT LCD Module

Item	Symbol	Min	Max	Unit	Conditions
Logic/LCD Drive	VDD	-0.3	6.0	[Volt]	Note 1, 2

4.2 Backlight Unit

Item	Symbol	Min	Max	Unit	Conditions
LED Forward Current	IFLED1	0	150	[mA]	Note 1,2,5 100% duty
	IFLED2				
	IFLED3				
	IFLED4				
LED Pulse Forward Current	IPLD1	-	210	[mA]	Note 1,2,5 Pulse width \leq 10msec and duty \leq 10%
	IPLD2				
	IPLD3				
	IPLD4				
LED forward Voltage variation (per string variation)	ΔV_f	-	3	[Volt]	Note 1,2,6

4.3 Absolute Ratings of Environment

Item	Symbol	Min.	Max.	Unit	Conditions
Operating Temperature	TOP	0	+50	[°C]	Note 3
Glass Surface Temperature (Operation)	TGS	0	+65	[°C]	Note3 Note4
Operation Humidity	HOP	5	90	[%RH]	Note 3
Storage Temperature	TST	-20	+60	[°C]	
Storage Humidity	HST	5	90	[%RH]	

Note 1: With in Ta (25 °C)

Note 2: Permanent damage to the device may occur if exceeding maximum values

Note 3: Temperature and relative humidity range are shown as the below figure.

1. 90% RH Max (Ta \leq 39°C)
2. Max wet-bulb temperature at 39°C or less. (Ta \leq 39°C)
3. No condensation

Note 4: Function Judged only

Note 5: IFLED1,2,3,4 and IPLD1,2,3,4 define as per strings LED current.

Note 6 : LED forward Voltage variation is define as voltage drop difference of each LED string in single LCD module.



Product Specification

M270HVN02.1

AU OPTRONICS CORPORATION

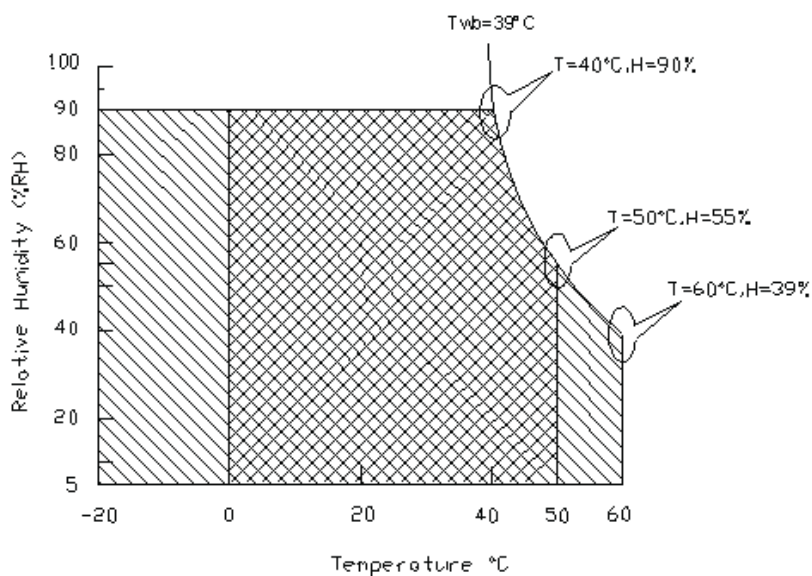

Operating Range  Storage Range  + 

www.panelook.com
 AUO Confidential For JUNGLIM Internal Use Only / 2013/3/26



Product Specification

M270HVN02.1

AU OPTRONICS CORPORATION

5 Electrical Characteristics

5.1 TFT LCD Module

5.1.1 Power Specification

Input power specifications are listed as follows:

Symbol	Description	Min	Typ.	Max	Unit	Conditions
VDD	Logic/LCD Drive Voltage	4.5	5.0	5.5	[Volt]	+/-10%
IDD1	Input Current	-	1.02	1.22	[A]	VDD= 5.0V, All white Pattern at 60 Hz
		-	1.21	1.45	[A]	VDD= 5.0V, All white Pattern at 75 Hz
PDD1	VDD Power	-	5.1	6.12	[Watt]	VDD= 5.0V, All white Pattern at 60 Hz
		-	6.05	7.26	[Watt]	VDD= 5.0V, All white Pattern at 75 Hz
IRush	Inrush Current	-	-	3	[A]	Note 1
VDDrp	Allowable Logic/LCD Drive Ripple Voltage	-	-	500	[mV] p-p	VDD= 5.0V, All white Pattern at 75 Hz

Note 1: Measurement Conditions:

The duration of rising time of power input is 470 us.

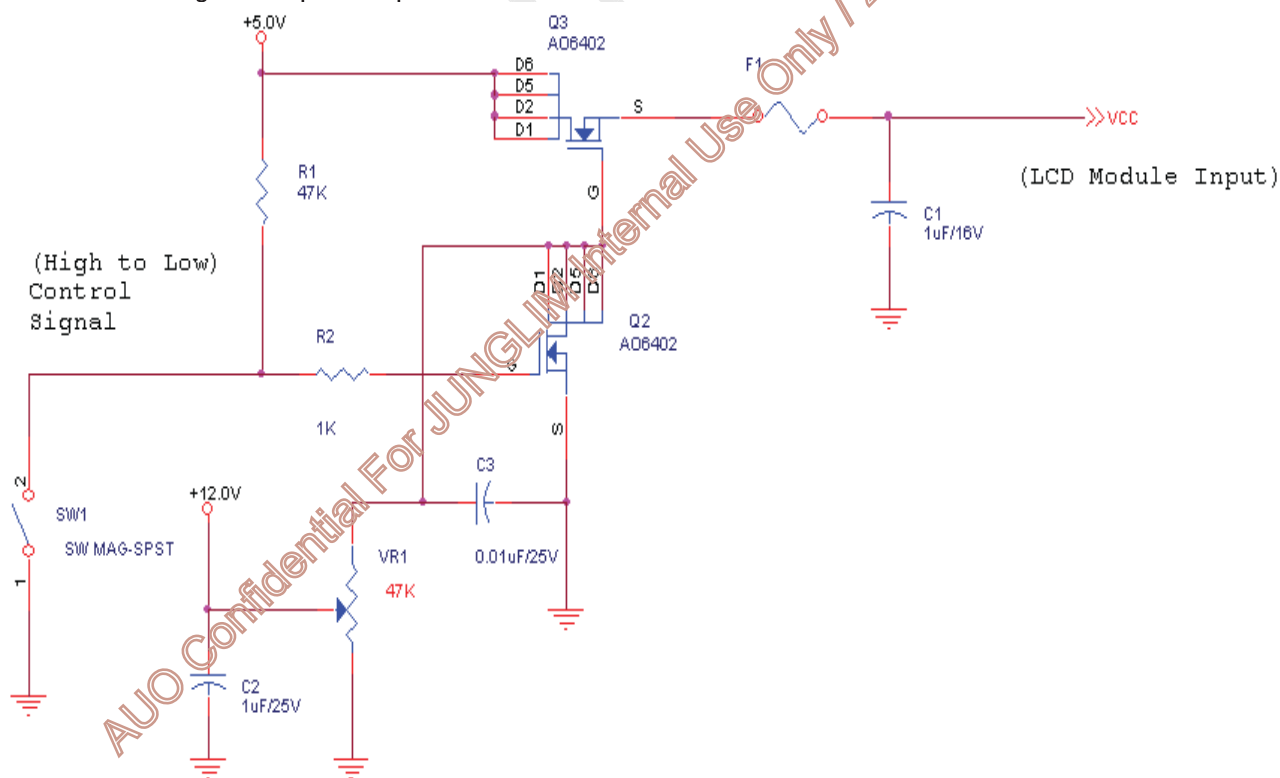



Product Specification

M270HVN02.1

AU OPTRONICS CORPORATION

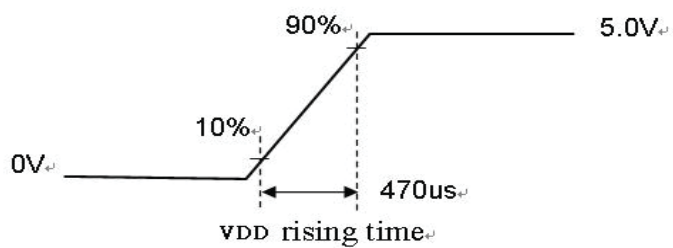

www.panelook.com
AUO Confidential For JUNGLIM Internal Use Only / 2013/3/26



Product Specification

M270HVN02.1

AU OPTRONICS CORPORATION

5.1.2 Signal Electrical Characteristics

(1) DC Characteristics of each signal are as following:

Symbol	Description	Min	Typ	Max	Units	Conditions
V_{TH}	Differential Input High Threshold	-	-	+100	[mV]	$V_{CM} = 1.2V$ Note 1
V_{TL}	Differential Input Low Threshold	-100	-	-	[mV]	$V_{CM} = 1.2V$ Note 1
$ V_{ID} $	Input Differential Voltage	100	-	600	[mV]	Note 1
V_{CM}	Differential Input Common Mode Voltage	+1.0	+1.2	+1.5	[V]	$V_{TH} - V_{TL} = 200MV$ (max) Note 1

Note 1: LVDS Signal Waveform

Single-End

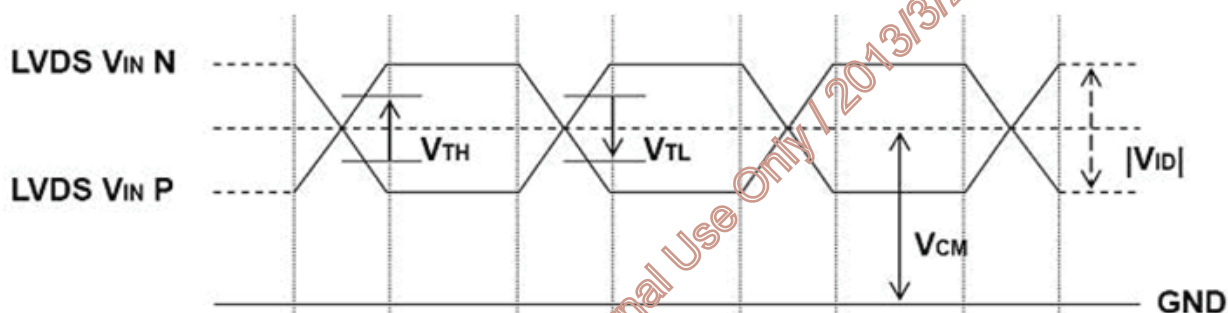

Differential Signal

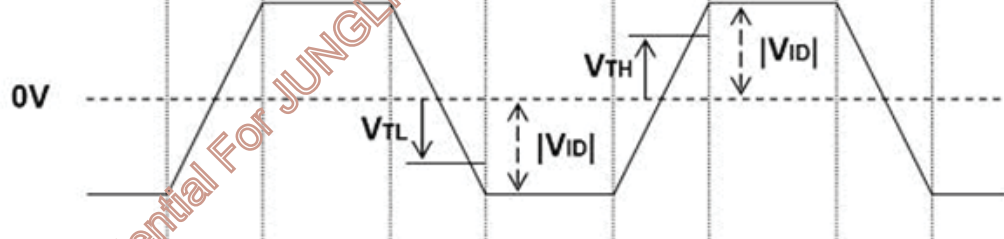



Product Specification

M270HVN02.1

AU OPTRONICS CORPORATION

(2) AC Characteristics

Symbol	Description	Min	Max	Units	Conditions
F_{DEV}	Maximum deviation of input clock frequency during SSC	-	± 3	%	
F_{MOD}	Maximum modulation frequency of input clock during SSC	-	200	KHz	

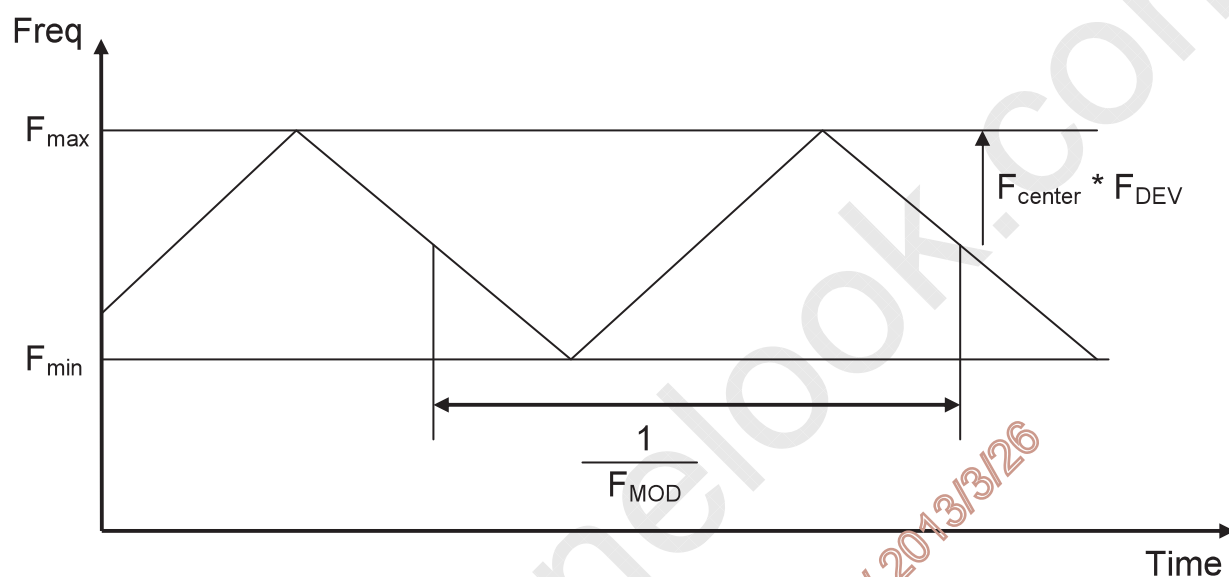

< Spread Spectrum >



Product Specification

M270HVN02.1

AU OPTRONICS CORPORATION

5.2 Backlight Unit

Parameter guideline for LED driving is under stable conditions at 25 °C (Room Temperature):

Symbol	Description	Min.	Typ.	Max.	Unit	Note
IFLED1	LED Forward Current	-	110	115.5	[mA]	Note 1
IFLED2						
IFLED3						
IFLED4						
VSLED	Light Bar Operation Voltage (for reference)	44.25	49.5	54	[Volt]	Note 2
PBLU	BLU Power Consumption (for reference)	-	21.78	24.95	[Watt]	Note 3
LTLED	LED Life Time (Typical)	30,000	-	-	[Hour]	Note 4

Each module consists of 60 pcs LED (4 strings x 15 pcs / string)

Note 1: The specified current is 100% duty of LED chip input current, IFLED1,2,3,4 define as per strings LED current.

Note 2: The value showed is one string operation voltage.

Note 3: $PBLU = VSLED * (IFLED1 + IFLED2 + IFLED3 + IFLED4)$

Note 4: Definition of life time: Brightness becomes to 50% of its original value. The minimum life time of LED unit is on the condition of IFLED = 110mA and 25±2°C (Room Temperature).



Product Specification

M270HVN02.1

AU OPTRONICS CORPORATION

6 Signal Characteristics

6.1 Pixel Format Definition

Following figure shows the relationship between the input signals and LCD pixel format.

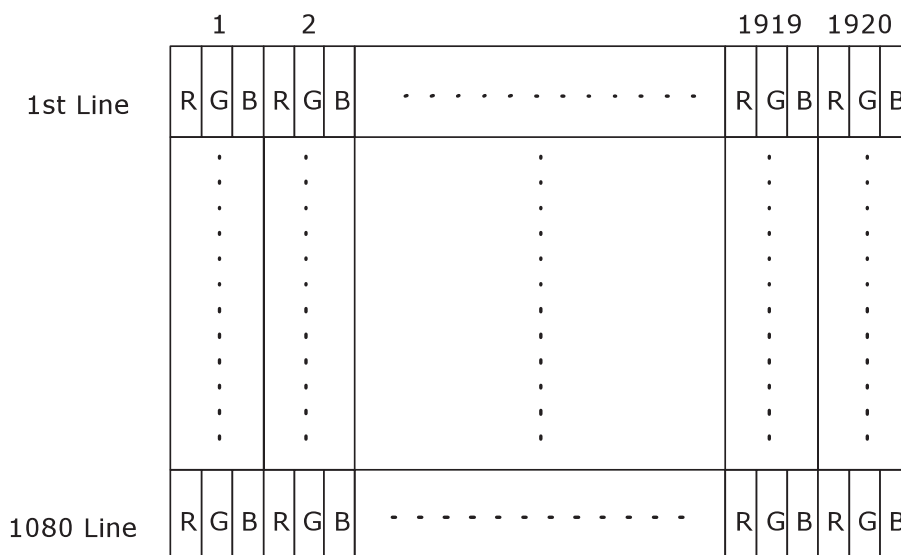

6.2 Input Data Format Definition

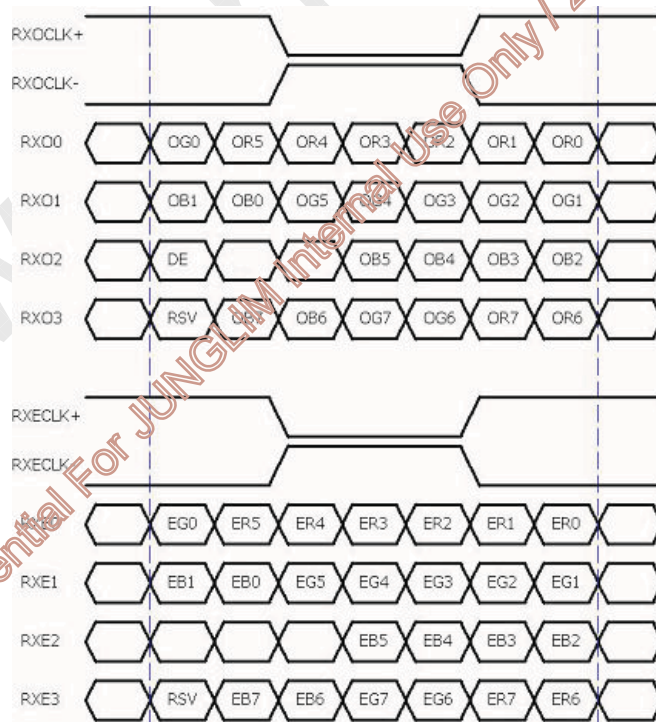

- Note1: Normally, DE, VS, HS on EVEN channel are not used.
- Note2: Please follow PSWG.
- Note3: 8-bit in



Product Specification

M270HVN02.1

AU OPTRONICS CORPORATION

6.3 Signal Description

PIN #	SIGNAL	DESCRIPTION
1	RXO0-	Negative LVDS differential data input (Odd data)
2	RXO0+	Positive LVDS differential data input (Odd data)
3	RXO1-	Negative LVDS differential data input (Odd data)
4	RXO1+	Positive LVDS differential data input (Odd data)
5	RXO2-	Negative LVDS differential data input (Odd data, H-Sync,V-Sync,DSPTMG)
6	RXO2+	Positive LVDS differential data input (Odd data, H-Sync,V-Sync,DSPTMG)
7	GND	Power Ground
8	RXOCLK-	Negative LVDS differential clock input (Odd clock)
9	RXOCLK+	Positive LVDS differential clock input (Odd clock)
10	RXO3-	Negative LVDS differential data input (Odd data)
11	RXO3+	Positive LVDS differential data input (Odd data)
12	RXE0-	Negative LVDS differential data input (Even data)
13	RXE0+	Positive LVDS differential data input (Even data)
14	GND	Power Ground
15	RXE1-	Negative LVDS differential data input (Even data)
16	RXE1+	Positive LVDS differential data input (Even data)
17	GND	Power Ground
18	RXE2-	Negative LVDS differential data input (Even data)
19	RXE2+	Positive LVDS differential data input (Even data)
20	RXECLK-	Negative LVDS differential clock input (Even clock)
21	RXECLK+	Positive LVDS differential clock input (Even clock)
22	RXE3-	Negative LVDS differential data input (Even data)
23	RXE3+	Positive LVDS differential data input (Even data)
24	GND	Power Ground
25	GND	Power Ground (For AUO test Aging+HVS mode)
26	NC	No contact
27	GND	Power Ground
28	VDD	+5.0V Power Supply
29	VDD	+5.0V Power Supply
30	VDD	+5.0V Power Supply

Note 1: Input signals of odd and even clock shall be the same timing.



Product Specification

M270HVN02.1

AU OPTRONICS CORPORATION

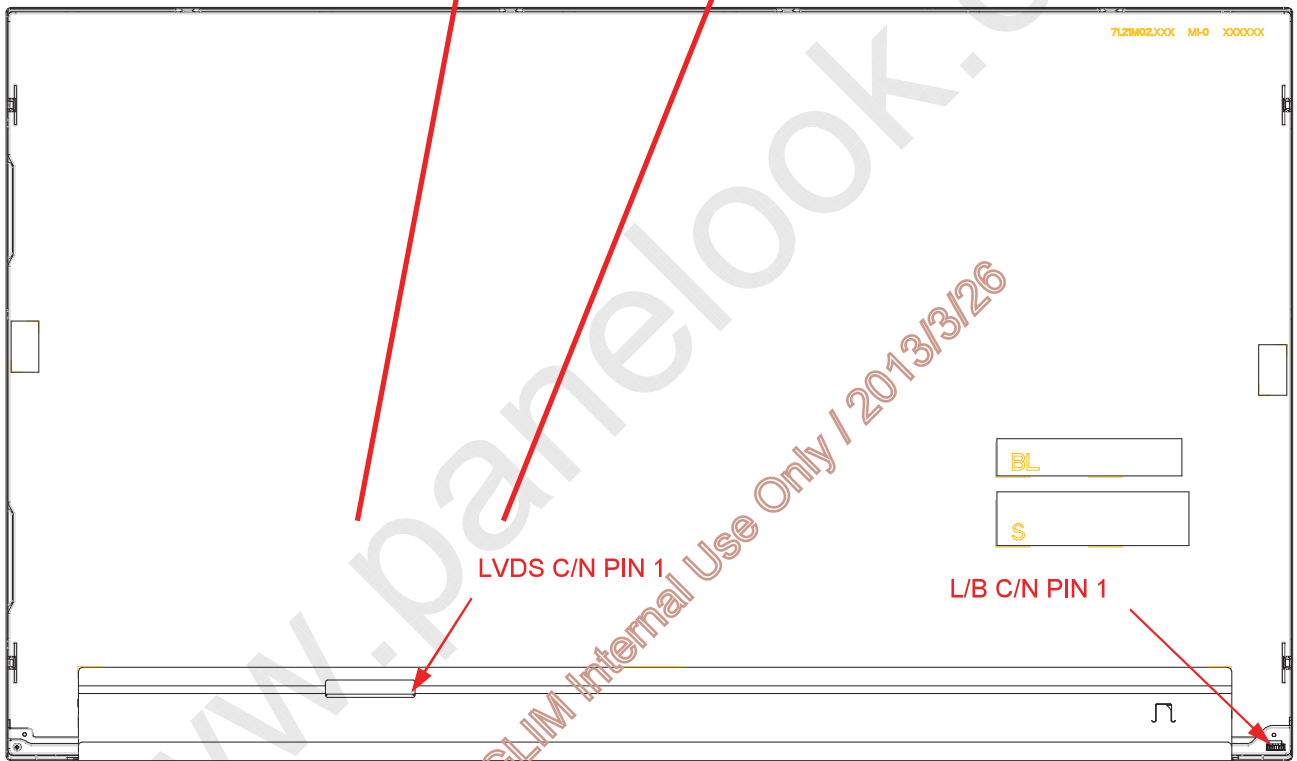
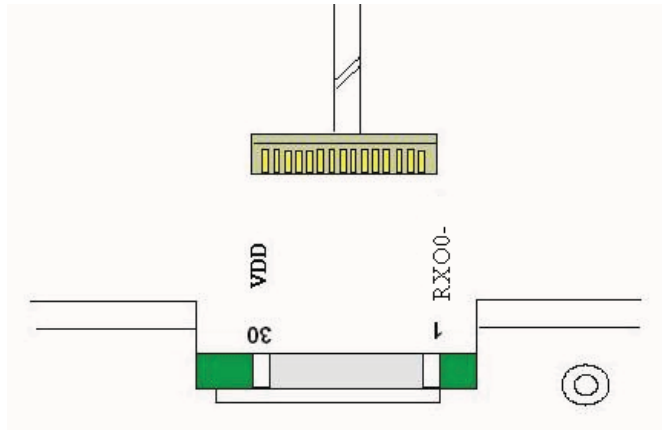

www.panelook.com
 AUO Confidential For JUNGLIM Internal Use Only / 2013/3/26



Product Specification

M270HVN02.1

AU OPTRONICS CORPORATION

6.4 Timing Characteristics

The input signal timing specifications are shown as the following table

Signal	Item	Symbol	Min	Typ	Max	Unit
Vertical Section	Period	Tv	1092	1130	1793	Th
	Active	Tdisp(v)	1080	1080	1080	Th
	Blanking	Tblk(v)	12	50	713	Th
Horizontal Section	Period	Th	1004	1050	1100	Tclk
	Active	Tdisp(h)	960	960	960	Tclk
	Blanking	Tblk(h)	44	90	140	Tclk
Clock	Period	Tclk	11.1	14.0	18.2	ns
	Frequency	Freq	54.8	71.2	90.0	MHz
Frame rate	Frame rate	VFreq	50	60	76	Hz
Hsync Frequency	Hsync Frequency	HFreq	55	68	90	KHz

Note 1: DE mode only



Product Specification

M270HVN02.1

AU OPTRONICS CORPORATION

6.5 Timing Diagram

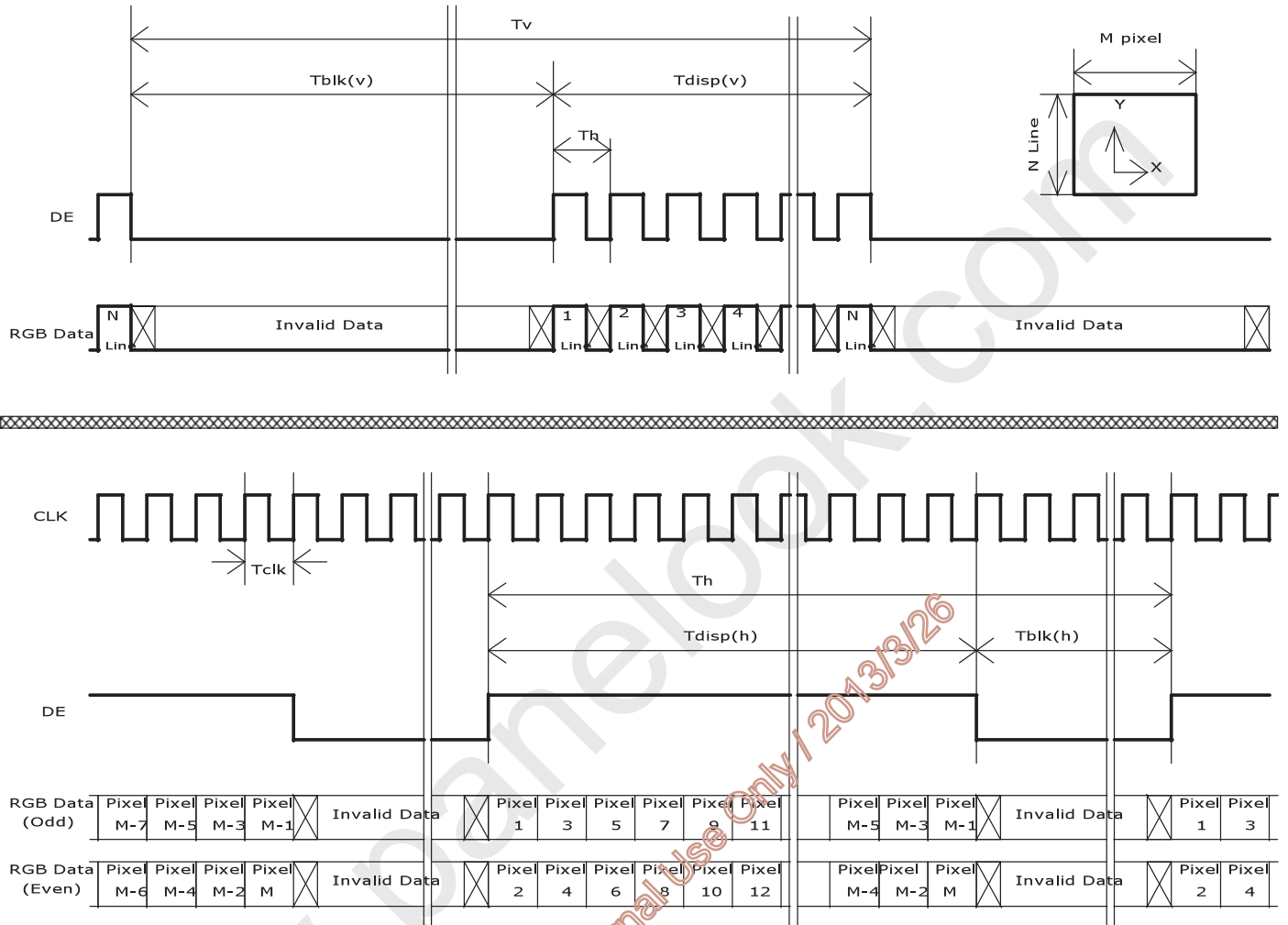



Product Specification

M270HVN02.1

AU OPTRONICS CORPORATION

6.6 Power ON/OFF Sequence

VDD power and lamp on/off sequence are as follows. Interface signals are also shown in the chart. Signals from any system shall be Hi-Z state when VDD is off.

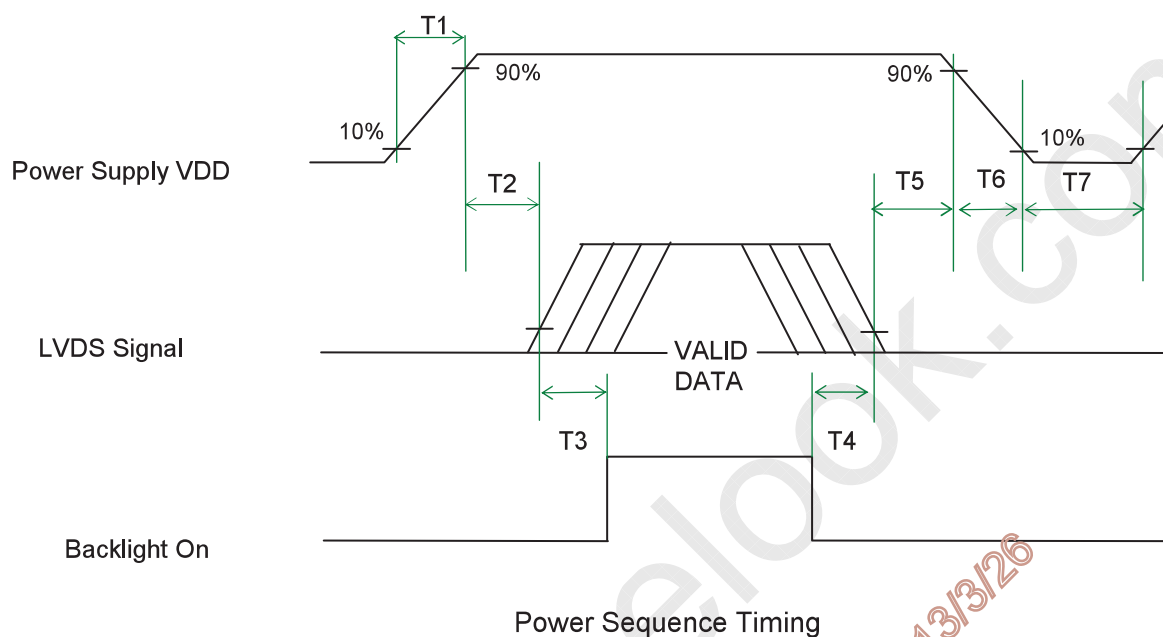

Parameter	Value			Unit
	Min.	Typ.	Max.	
T1	0.5	-	10	[ms]
T2	0	-	50	[ms]
T3	500	-	-	[ms]
T4	100	-	-	[ms]
T5	0	-	50	[ms] Note 1, 2
T6	5	-	100	[ms] Note 1, 2
T7	1000	-	-	[ms]

Note1 : Recommend setting T5 = 0ms to avoid electronic noise when VDD is off.

Note2 : During T5 and T6 period , please keep the level of input LVDS signals with Hi-Z state.



Product Specification

M270HVN02.1

AU OPTRONICS CORPORATION

7 Connector and Pin Assignment

Physical interface is described as for the connector on module. These connectors are capable of accommodating the following signals and will be following components.

7.1 TFT LCD Module

Connector Name / Designation	Interface Connector / Interface Card
Manufacturer	STM P-TWO STARCONN
Type Part Number	MSCKT2407P30HB AL230F-A0G1D-P 093G30-02001A-M4
Mating Housing Part Number	FI-X30HL (Locked Type)

7.1.1 Pin Assignment

Pin#	Signal Name	Pin#	Signal Name
1	RX00-	2	RX00+
3	RX01-	4	RX01+
5	RX02-	6	RX02+
7	GND	8	RXOCLK-
9	RXOCLK+	10	RX03-
11	RX03+	12	RXE0-
13	RXE0+	14	GND
15	RXE1-	16	RXE1+
17	GND	18	RXE2-
19	RXE2+	20	RXECLK-
21	RXECLK+	22	RXE3-
23	RXE3+	24	GND
25	GND (AGMODE+HVS)	26	NC
27	GND	28	VDD
29	VDD	30	VDD



Product Specification

M270HVN02.1

AU OPTRONICS CORPORATION

7.2 LED Connector on Backlight Unit

This connector is mounted on LED light bar.

Connector Name / Designation	Light Bar Connector
Manufacturer	E&T(ENTERY)
Type Part Number	3707K-S06N-21R
Mating Housing Part Number	H112K-P06N-13B (Locked Type)

7.2.1 LED Pin assignment

Pin#	Signal Name
1	IFLED (current return)
2	IFLED (current return)
3	VSLED (voltage in)
4	VSLED (voltage in)
5	IFLED (current return)
6	IFLED (current return)

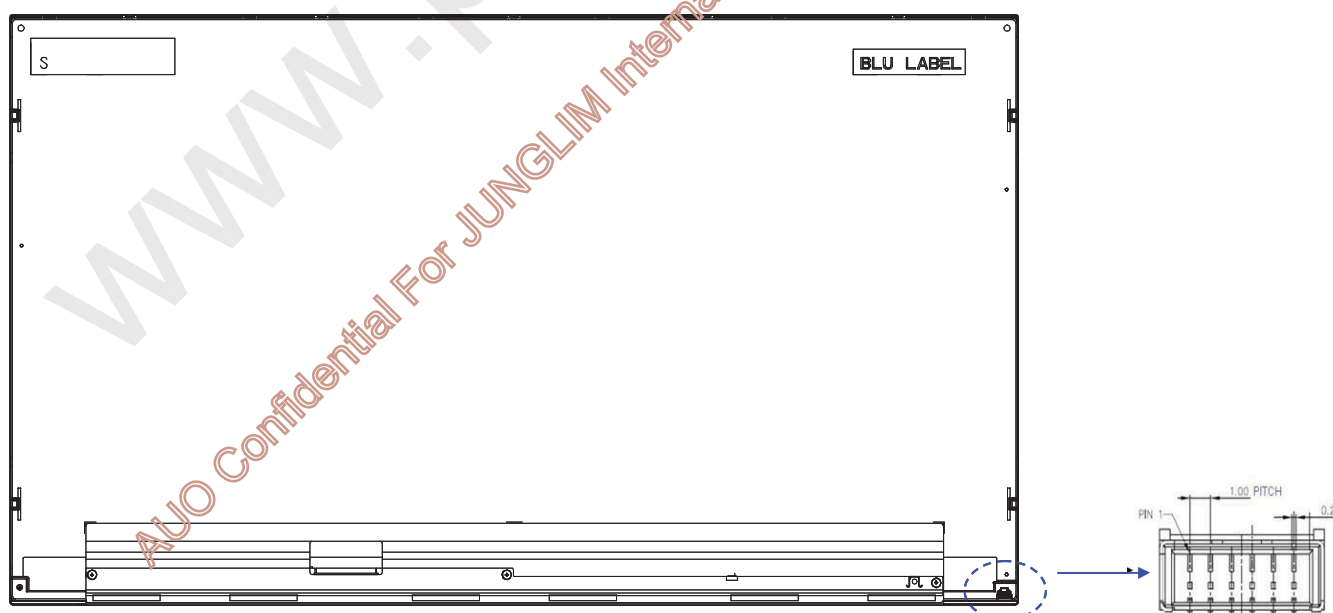



Product Specification

M270HVN02.1

AU OPTRONICS CORPORATION

7.2.2 LED Connector Dimension

$$H \times V \times D = 13.9 \times 3.00 \times 4.25, \text{Pitch} = 1.0 (\text{unit} = \text{mm})$$

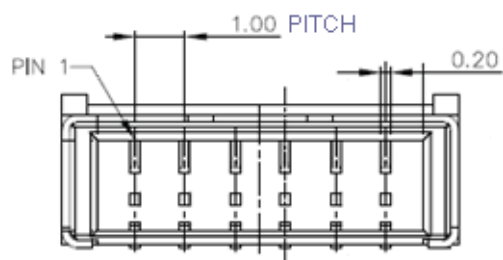
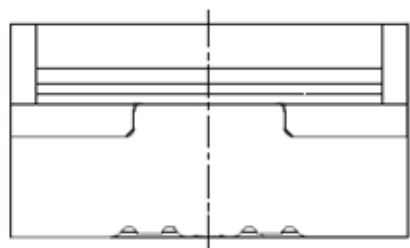

7.2.3 LED Mating housing dimension

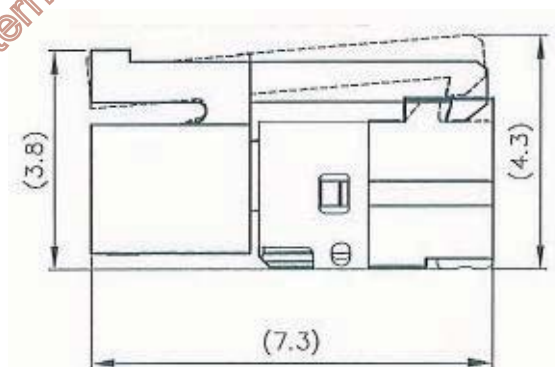
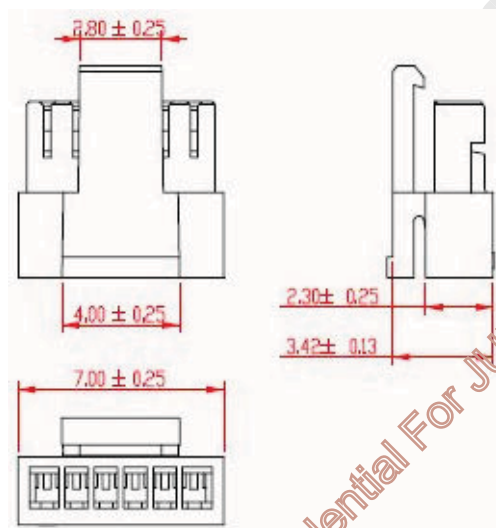



Product Specification

M270HVN02.1

AU OPTRONICS CORPORATION

8 Reliability Test

Environment test conditions are listed as following table.

Items	Required Condition	Note
Temperature Humidity Bias (THB)	Ta= 50°C, 80%RH, 300 hours	
High Temperature Operation (HTO)	Ta= 50°C, 50%RH, 300 hours	
Low Temperature Operation (LTO)	Ta= 0°C, 300 hours	
High Temperature Storage (HTS)	Ta= 60°C, 300 hours	
Low Temperature Storage (LTS)	Ta= -20°C, 300 hours	
Vibration Test (Non-operation)	Acceleration: 1.5 Grms Wave: Random Frequency: 10 - 200 Hz Duration: 30 Minutes each Axis (X, Y, Z)	
Shock Test (Non-operation)	Acceleration: 50 G Wave: Half-sine Active Time: 20 ms Direction: ±X, ±Y, ±Z (one time for each Axis)	
Drop Test	Height: 46 cm, package test	
Thermal Shock Test (TST)	-20°C/30min, 60°C/30min, 100 cycles	Note 1
On/Off Test	On/10sec, Off/10sec, 30,000 cycles	
ESD (Electro Static Discharge)	Contact Discharge: ± 15KV, 150pF(330Ω) 1sec, 15 points, 25 times/ point	Note 2
	Air Discharge: ± 15KV, 150pF(330Ω) 1sec 15 points, 25 times/ point	
Altitude Test	Operation: 18,000 ft Non-Operation: 40,000 ft	Note 3

Note 1: The TFT-LCD module will not sustain damage after being subjected to 100 cycles of rapid temperature change. A cycle of rapid temperature change consists of varying the temperature from -20°C to 60°C, and back again. Power is not applied during the test. After temperature cycling, the unit is placed in normal room ambient for at least 4 hours before power on.

Note 2: EN61000-4-2, ESD class B: Certain performance degradation allowed:

- No data lost
- Self-recoverable
- No hardware failures



Product Specification

M270HVN02.1

AU OPTRONICS CORPORATION

9 Shipping Label

The label on the panel is shown as below:

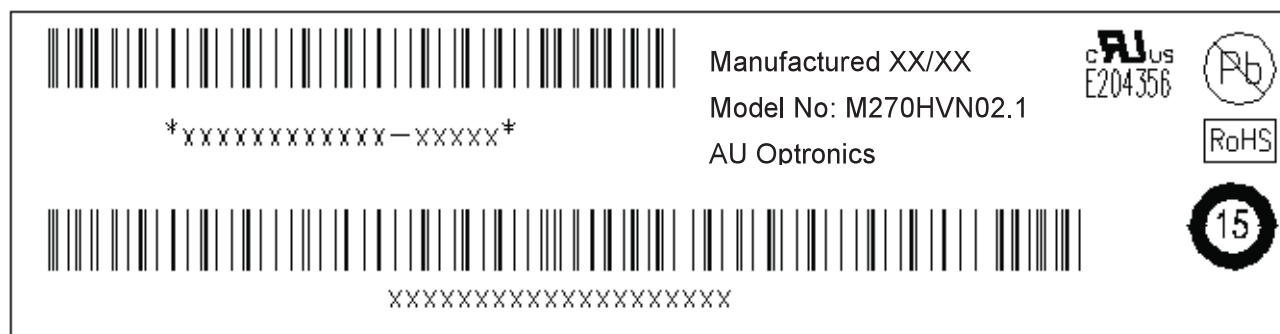

Note 1: For Pb Free products, AUO will add  for identification.

Note 2: For RoHS compatible products, AUO will add  for identification.

Note 3: For China RoHS compatible products, AUO will add  for identification.

Note 4: The Green Mark will be presented only when the green documents have been ready by AUO Internal Green Team.

www.panelook.com
 AUO Confidential For JUNGLIM Internal Use Only / 2013/3/26



Product Specification

M270HVN02.1

AU OPTRONICS CORPORATION

10 Mechanical Characteristics

Front Face

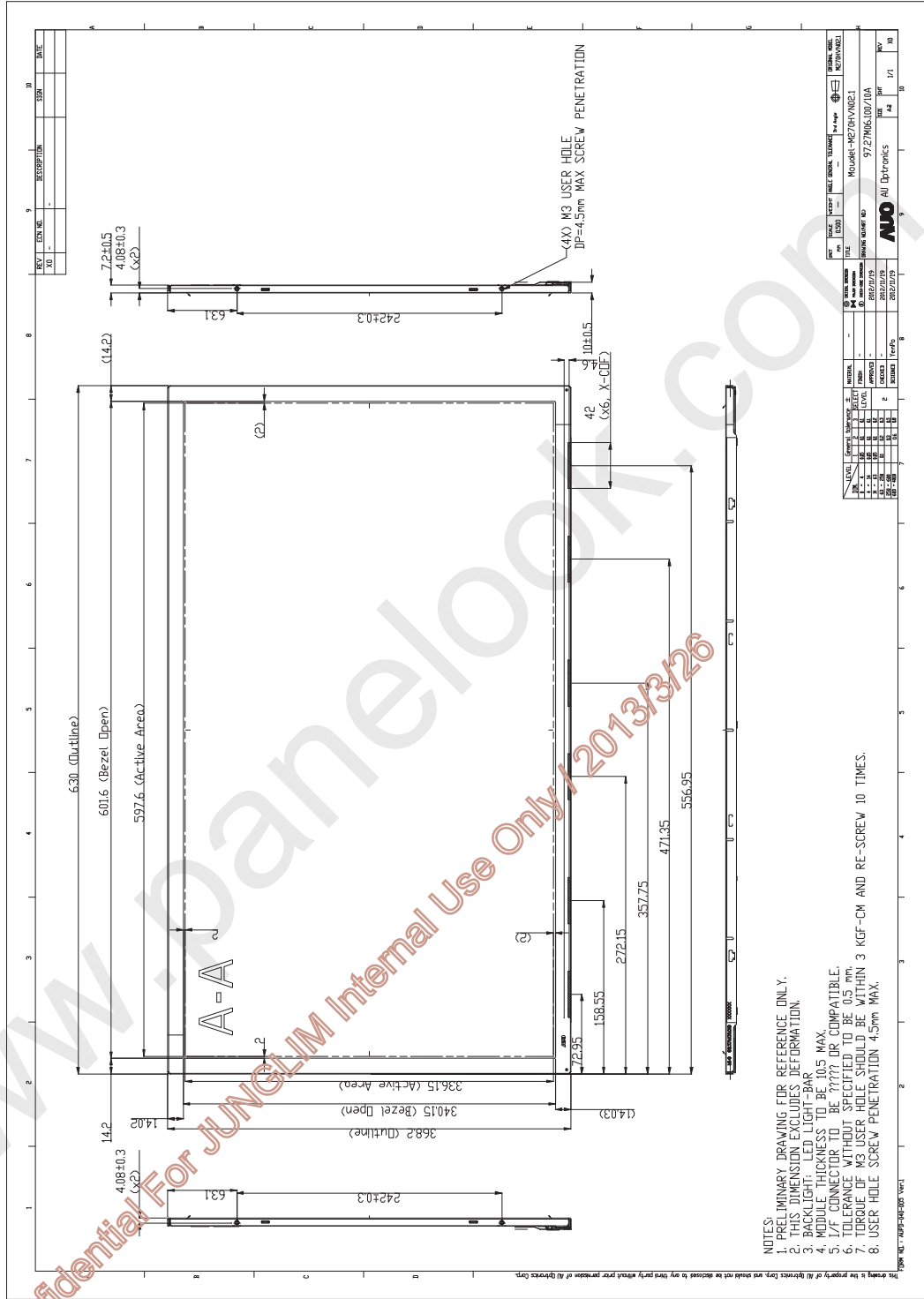



Product Specification

AU OPTRONICS CORPORATION

M270HVN02.1

Back Face:

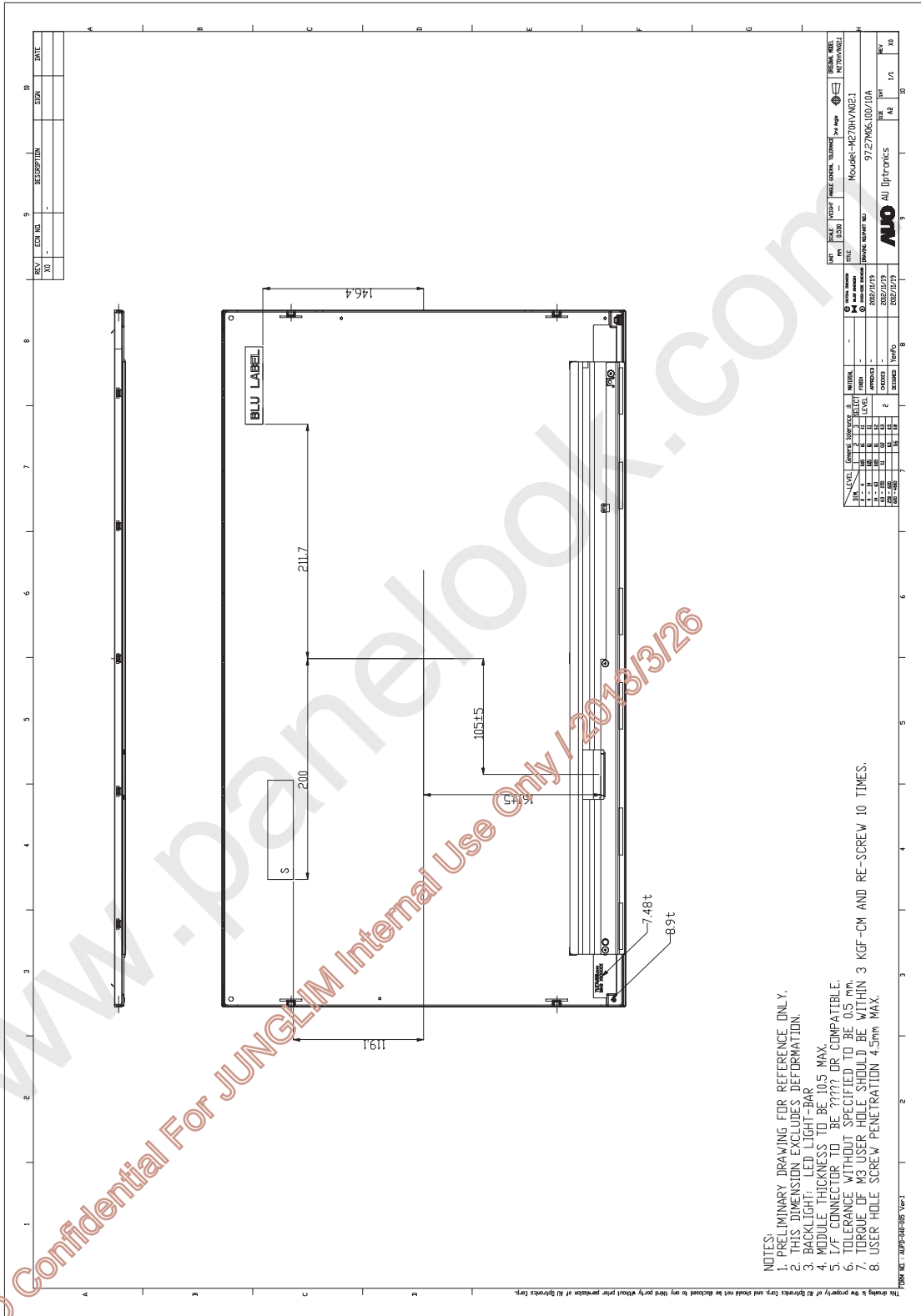

- NOTES:
1. PRELIMINARY DRAWING FOR REFERENCE ONLY.
 2. THIS DIMENSION EXCLUDES DEFORMATION.
 3. BACKLIGHT LED LIGHT BAR
 4. MODULE THICKNESS TO BE 10.5 MAX.
 5. I/F CONNECTOR TO BE ??? FOR COMPATIBLE.
 6. TOLERANCE WITHOUT SPECIFIED TO BE 0.5.
 7. TORQUE OF M3 USER NUT SHOULD BE WITHIN 3 KGF-CM AND RE-SCREW 10 TIMES.
 8. USER HOLE SCREW PENETRATION 4.5mm MAX.



Product Specification

M270HVN02.1

AU OPTRONICS CORPORATION

**Avoid touching COF position
when doing mechanical design**

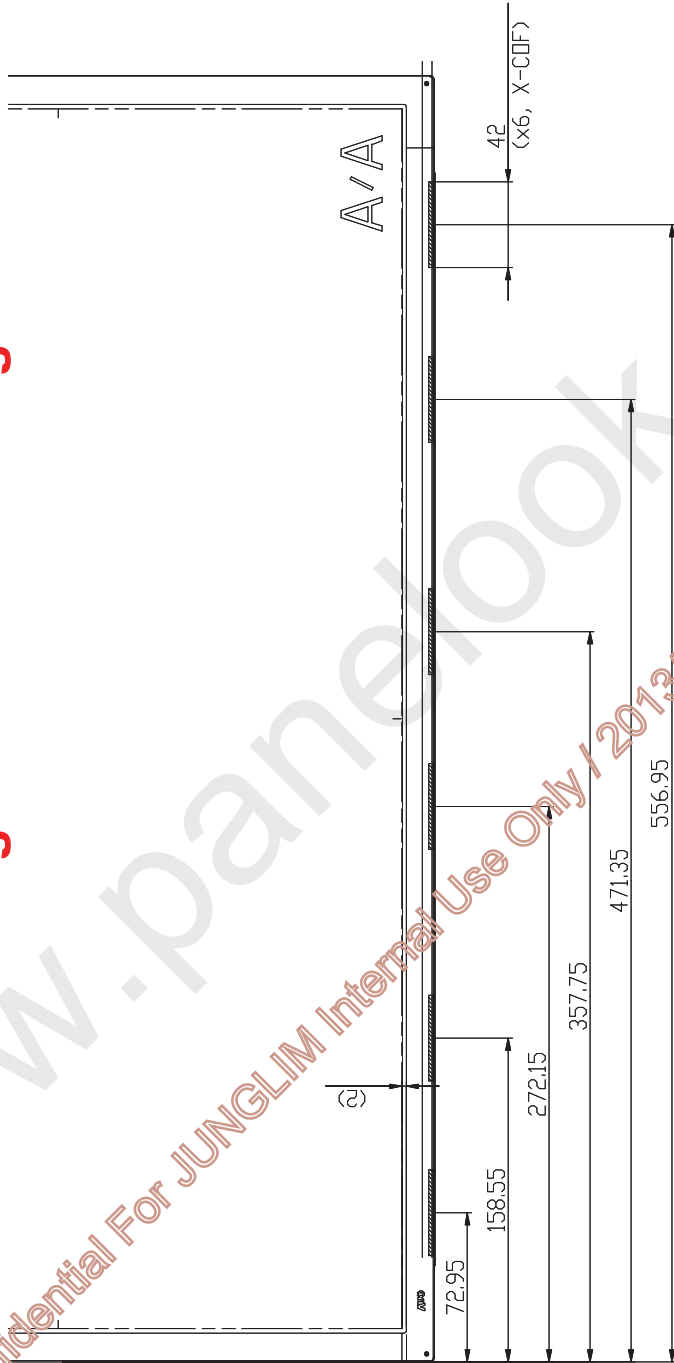

www.panelook.com
AUO Confidential For JUNGLIM Internal Use Only / 2013/3/26



Product Specification

M270HVN02.1

AU OPTRONICS CORPORATION

11 Packing Specification

11.1 Packing Flow

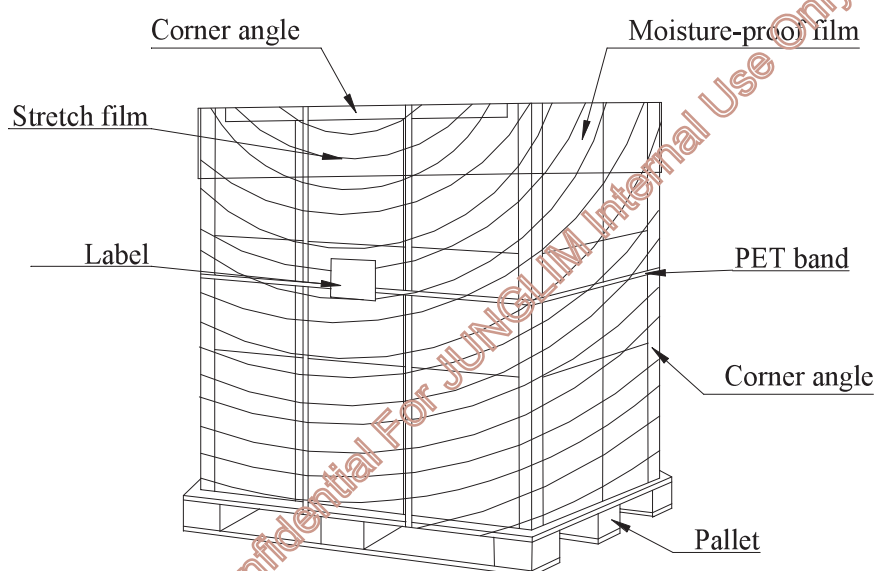
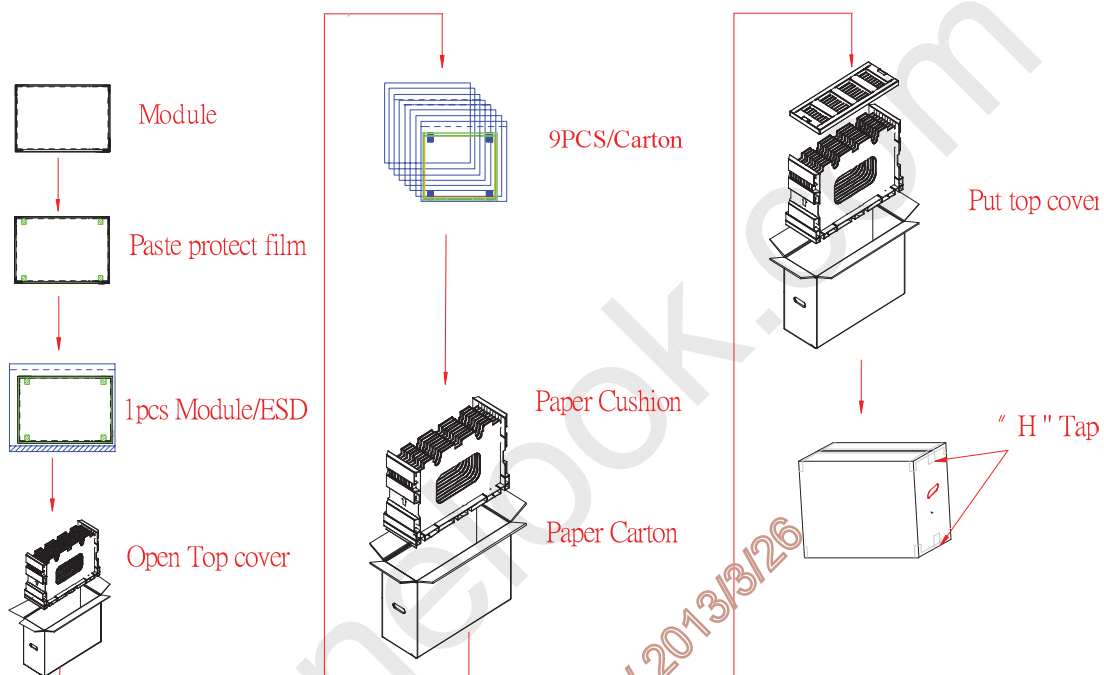



Product Specification

M270HVN02.1

AU OPTRONICS CORPORATION

11-2 Pallet and shipment information

	Item	Specification			Remark
		Q'ty	Dimension	Weight(kg)	
1	Panel	1	630mmx368.2mmx10.0mm	2.3	
2	Cushion	1	-	4.41	
3	Box	1	720(L)mm x 264(W)mm x 460(H)mm	1.35	without Panel & cushion
4	Packing Box	9 pcs/Box	720(L)mm x 264(W)mm x 460(H)mm	26.46	with panel & cushion
5	Pallet	1	1070(L)mm x 740(W)mm x 138(H)mm	12.9	
6	Pallet after Packing	8 boxes/pallet	1070(L)mm x 740(W)mm x 138(H)mm	224.6	