

# Product Specifications

<b>Customer</b>	
<b>Description</b>	<b>7" TFT LCD Module</b>
<b>Model Name</b>	<b>LW700AT9309</b>
<b>Date</b>	<b>2009/04/06</b>
<b>Doc. No.</b>	
<b>Revision</b>	<b>02</b>

## Customer Approval

<b>Date</b>	
-------------	--

The above signature represents that the product specifications, testing regulation, and warranty in the specifications are accepted

## Engineering

<b>Check</b>	<b>Date</b>	<b>Prepared</b>	<b>Date</b>
		<b>Jenny Tsai</b>	<b>2009.04.06</b>

Head Office & Factory : No. 12, Nanke 8<sup>th</sup> Rd., Tainan Science-Based Industrial Park, Taiwan, 74144 R.O.C.

TEL: +886-6-5889980  
FAX: +886-6-5051522

**CONTENTS**

No.	ITEM	PAGE
0	RECORD OF REVISION	3
1	SUMMARY	4
2	FEATURES	4
3	GENERAL SPECIFICATIONS	4
4	ABSOLUTE MAXIMUM RATINGS	4
5	ELECTRICAL CHARACTERISTICS	5
6	AC CHARACTERISTICS	6~7
7	OPTICAL CHARACTERISTIC	8~10
8	INTERFACE	11
9	BLOCK DIAGRAM	12
10	QUALITY ASSURANCE	12
11	OUTLINE DRAWING	13
12	PACKAGE INFORMATION	14
13	PRECAUTIONS	15~16



### 1. SUMMARY

This technical specification applies to 7" TFT-LCD module with a LED Backlight unit and a 40-pin TTL interface. This module supports 800\*R.G.B x 480 WVGA mode and can display 262,144 colors.

### 2. FEATURES

- Thin and Light Weight.
- WVGA(800x480 pixels) resolution.
- 3.3 V TTL interface

### 3. GENERAL SPECIFICATIONS

Parameter	Specifications	Unit
Screen size	7"(Diagonal)	inch
Display Resolution	800 RGB x 480	pixel
Active area	152.4x91.44	mm
Dot Pitch	63.5 x 190.5	um
Pixel size	190.5 x 190.5	um
Surface treatment	Anti-glare	
Color Saturation (NTSC)	45	%
Pixel Configuration	RGB Vertical Stripe	
Outline dimension	165(W) x 104.44(H) x 5.2 (D)	mm
Weight	TBD	g
View Angle direction (Gray inversion)	6 o'clock	--
Interface Type	TTL	--
LCD Type	TN	--
Color Depth	262,144	colors

### 4. ABSOLUTE MAXIMUM RATINGS (GND=0V)

Item	Symbol	Condition	Min.	Max.	Unit	Remark
Power Voltage	Vcc	GND=0	-0.3	6	V	-
Input logic voltage	Vi	GND=0	-0.3	Vcc+0.3	V	Note 1

Note 1: DCLK, DE, R0~ R5, G0~ G5, B0~ B5.

**5. ELECTRICAL CHARACTERISTICS**

**5.1 Recommended Operation condition (GND=0V , Ta=25°C)**

Parameter	Symbol	Rating			Unit	Condition	
		Min.	Typ.	Max.			
Power Supply Voltage	V <sub>CC</sub>	3.0	3.3	3.6	V		
Input logic voltage	High Level	V <sub>IH</sub>	0.7V <sub>CC</sub>	-	V <sub>CC</sub>	V	Note 1
	Low Level	V <sub>IL</sub>	0	-	0.3V <sub>CC</sub>	V	Note 1

Note 1: DCLK, DE, R0~ R5, G0~ G5, B0~ B5.

**5.2 LED Driving Conditions**

Ta = 25°C

Parameter	Symbol	Min.	Typ.	Max.	Unit	Remark
LED current	I <sub>LED</sub>	-	160	-	mA	Note 1
LED voltage	V <sub>LED</sub>	-	9.9	-	V	
LED Life Time	-	10,000	20,000	-	Hr	Note 2

Note 1 : There are 8 Groups LED shown as below , V<sub>LED</sub>=9.9V , I<sub>LED</sub>=160mA.

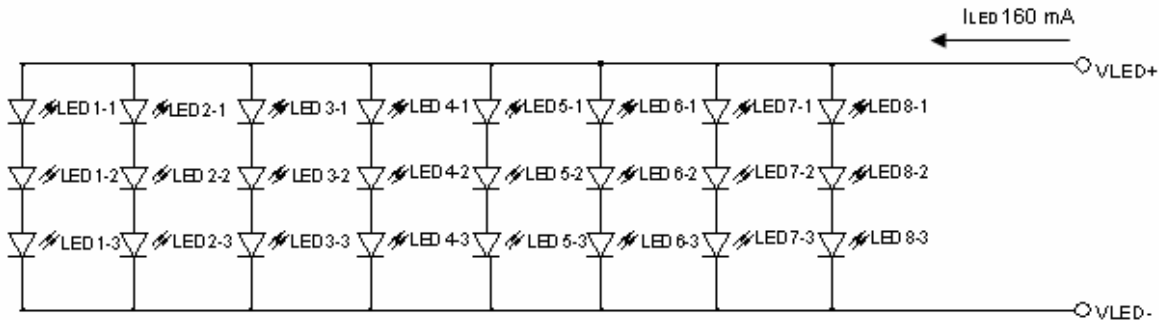

Note 2 : Brightness to be decreased to 50% of the initial value.

**5.3 TFT-LCD current consumption**

Parameter	Symbol	Rating			Unit	Condition
		Min.	Typ.	Max.		
LCD power current	I <sub>CC</sub>	--	200	260	mA	black pattern
LED power current	I <sub>LED</sub>	--	160	200	mA	

**6. AC CHARACTERISTICS**

**6.1 AC Electrical CHARACTERISTICS**

Frame rate range : 60Hz~65Hz

Parameter	Symbol	Rating			Unit
		Min.	Typ.	Max.	
Data setup time	Tdsu	6	-	-	ns
Data hold time	Tdhd	6	-	-	ns
DE setup time	Tesu	6	-	-	ns
CLK frequency	F <sub>CPH</sub>	29.40	33.26	42.48	MHz
CLK period	T <sub>CPH</sub>	23.54	30.06	34.01	ns
CLK pulse duty	T <sub>CWH</sub>	40	50	60	%
CLK pulse duty	T <sub>CWL</sub>	40	50	60	%
DE period	T <sub>DEH</sub> +T <sub>DEL</sub>	1000	1056	1200	T <sub>CPH</sub>
DE pulse width	T <sub>DEH</sub>	-	800	-	T <sub>CPH</sub>
DE frame blanking	T <sub>DEB</sub>	10	45	110	T <sub>DEH</sub> +T <sub>DEL</sub>
DE frame width	T <sub>DE</sub>	-	480	-	T <sub>DEH</sub> +T <sub>DEL</sub>

Note : We suggest using the typical value, so it can have better performance.

**6.2 Timing Controller Timing Chart**

**Clock and Data input waveforms**

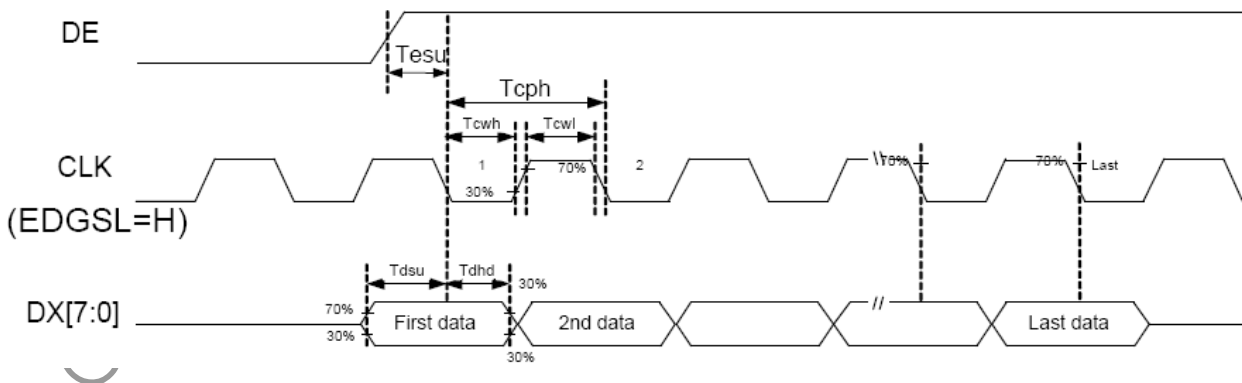

**6.3 Data input format**

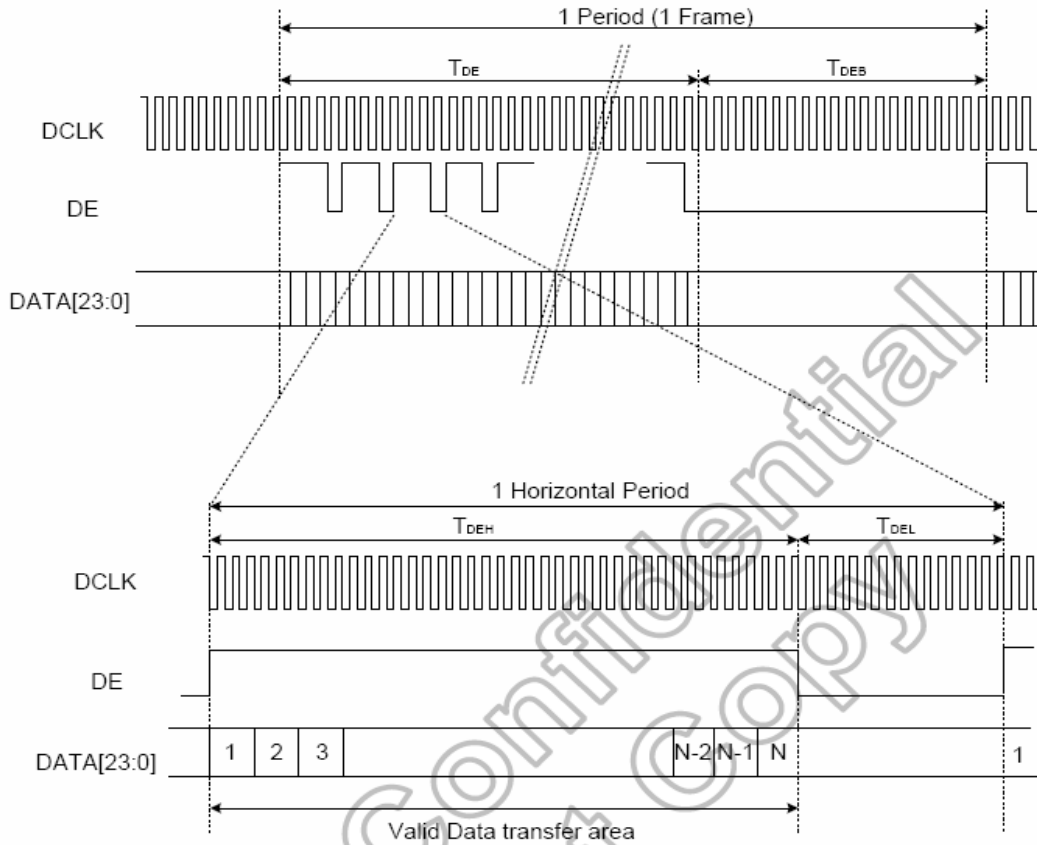

**6.4 Power ON/OFF sequence**

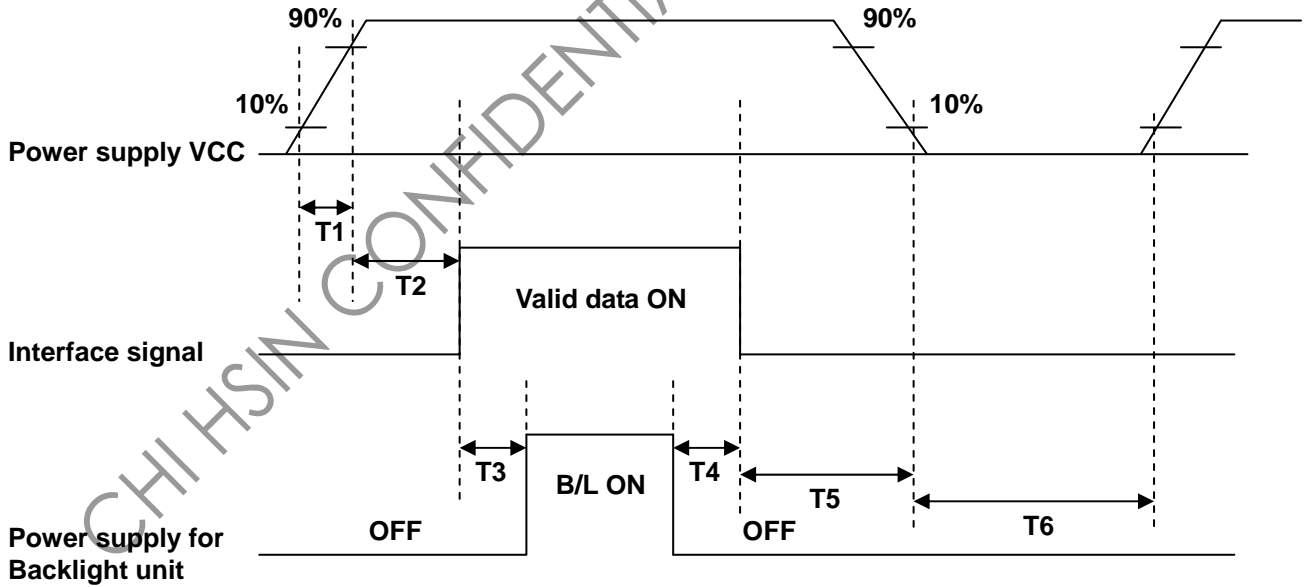

Parameter	SPEC.			Unit
	Min.	Typ.	Max.	
T1	1		2	ms
T2	0	60		ms
T3	200			ms
T4	200			ms
T5	1			ms
T6	1000			ms

**7. OPTICAL CHARACTERISTIC**

Item	Symbol	Condition	Min.	Typ.	Max.	Unit	Remark
Brightness	-	Viewing normal angle $\theta = \phi = 0$	300	350	-	cd/m <sup>2</sup>	Center of display
Response time	Tr		-	5	10	.ms	Note 3,5
	Tf		-	11	16	.ms	
Contrast ratio	CR		250	400	-	-	Note 4,5
Color Chromaticity	White		Wx	0.249	0.299	0.349	-
		Wy	0.278	0.328	0.378		
Viewing angle	Hor.	$\theta R$	60	70	-	Deg.	Note 1
		$\theta L$	60	70	-		
	Ver.	$\phi T$	50	60	-		
		$\phi B$	60	70	-		

Note 1: Definition of viewing angle range

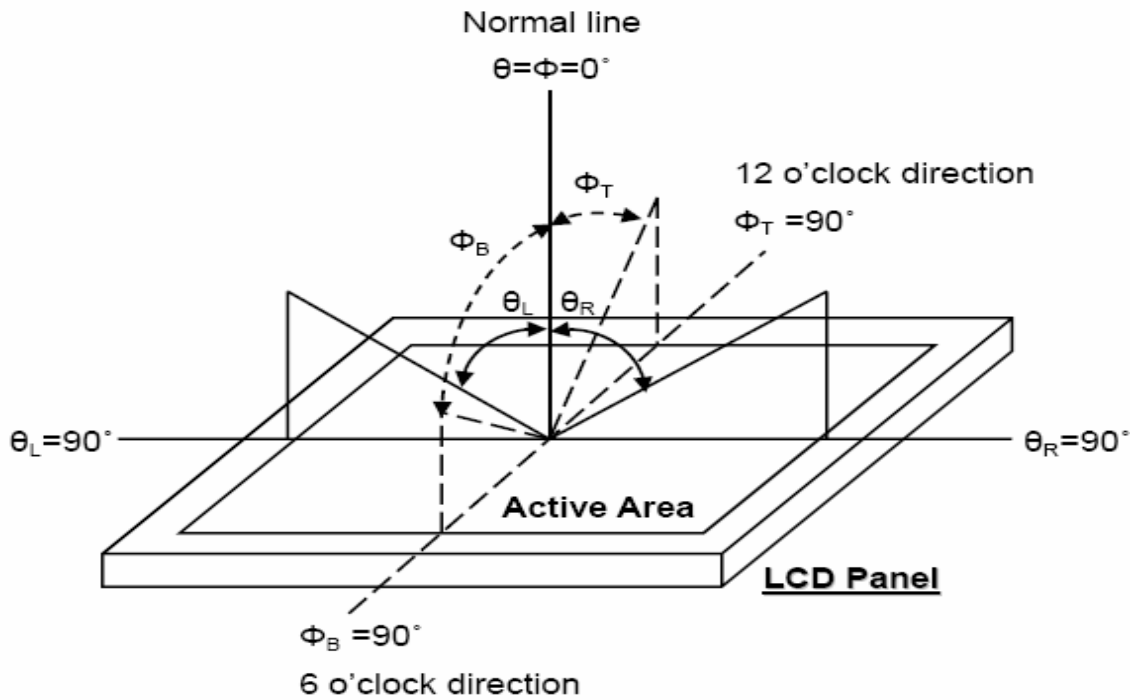

Fig. 7-1 Definition of viewing angle

Note 2: Test equipment setup:

After stabilizing and leaving the panel alone at a driven temperature for 10 minutes, the measurement should be executed. Measurement should be executed in a stable, windless, and dark room. Optical specifications are measured by Topcon BM-7 luminance meter 1.0° field of view at a distance of 50cm and normal direction.



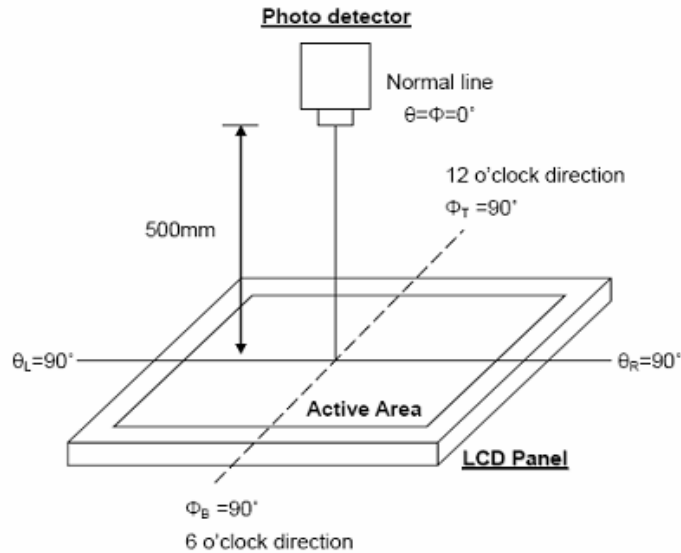

Fig.7-2 Optical measurement system setup

Note 3: Definition of Response time:

The response time is defined as the LCD optical switching time interval between “White state and “Black” state. Rise time,  $T_r$ , is the time between photo detector output intensity changed from 90% to 10% . And fall time,  $T_f$ , is the time between photo detector output Intensity changed from 10% to 90% .

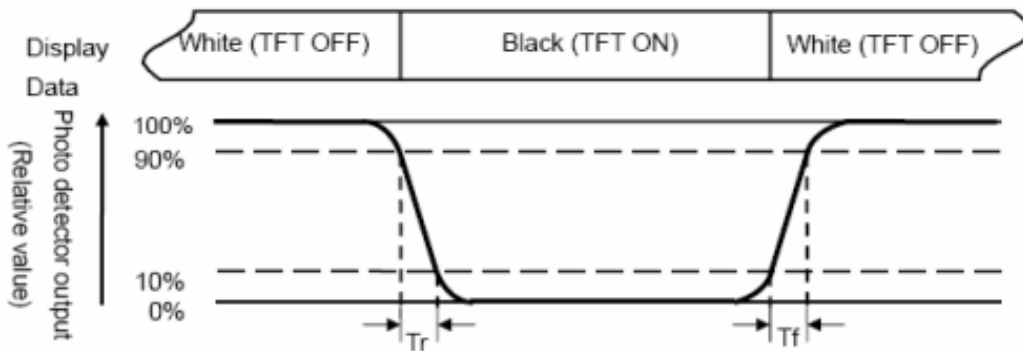

Fig. 3-3 Definition of response time

Note 4: Definition of contrast ratio:

The contrast ratio is defined as the following expression.

$$\text{Contrast ratio (CR)} = \frac{\text{Luminance measured when LCD on the "White" state}}{\text{Luminance measured when LCD on the "Black" state}}$$

Note 5: White  $V_i = V_{i50} \pm 1.5V$

Black  $V_i = V_{i50} \pm 2.0V$

“±” means that the analog input signal swings in phase with VCOM signal.

“±” means that the analog input signal swings out of phase with VCOM signal.

The 100% transmission is defined as the transmission of LCD panel when all the input terminals of module are electrically opened.

Note 6: Definition of color chromaticity (CIE 1931)  
Color coordinates measured at the center point of LCD

Note 7: Measured at the center area of the panel when all the input terminals of LCD panel are electrically opened.

Note 8 : Uniformity (U) =  $\frac{\text{Brightness (min)}}{\text{Brightness (max)}} \times 100\%$

CHI HSIN CONFIDENTIAL-FOR REVIEW ONLY

## 8. INTERFACE

### 8.1 LCM PIN Definition

Pin No.	Symbol	Description	Remark
1	GND	Power Ground	
2	GND	Power Ground	
3	NC	Not Connect	
4	Vcc	Power Supply for Digital Circuit	
5	Vcc	Power Supply for Digital Circuit	
6	Vcc	Power Supply for Digital Circuit	
7	Vcc	Power Supply for Digital Circuit	
8	NC	Not Connect	
9	DE	Data Enable	
10	GND	Power Ground	
11	GND	Power Ground	
12	GND	Power Ground	
13	B5	Blue Data 5 (MSB)	
14	B4	Blue Data 4	
15	B3	Blue Data 3	
16	GND	Power Ground	
17	B2	Blue Data 2	
18	B1	Blue Data 1	
19	B0	Blue Data 0 (LSB)	
20	GND	Power Ground	
21	G5	Green Data 5 (MSB)	
22	G4	Green Data 4	
23	G3	Green Data 3	
24	GND	Power Ground	
25	G2	Green Data 2	
26	G1	Green Data 1	
27	G0	Green Data 0 (LSB)	
28	GND	Power Ground	
29	R5	Red Data 5 (MSB)	
30	R4	Red Data 4	
31	R3	Red Data 3	
32	GND	Power Ground	
33	R2	Red Data 2	
34	R1	Red Data 1	
35	R0	Red Data 0 (LSB)	
36	GND	Power Ground	
37	GND	Power Ground	
38	DCLK	Clock Signals ; Latch Data at the Falling Edge	
39	GND	Power Ground	
40	GND	Power Ground	

Note: User's connector part number is **PF050-40ZSG-F09-S** manufactured by UJU or equivalent.

### 8.2 Backlight Driving Part

Pin No.	Symbol	Description
1	VLED+	Red, LED_ Anode
2	VLED-	White, LED_ Cathode

Note: The backlight interface connector is a model **BHSR-02VS-1** manufactured by JST or equivalent. The matching connector part number is **SM02B-BHSS-1-TB** manufactured by JST or equivalent.

**9. BLOCK DIAGRAM**

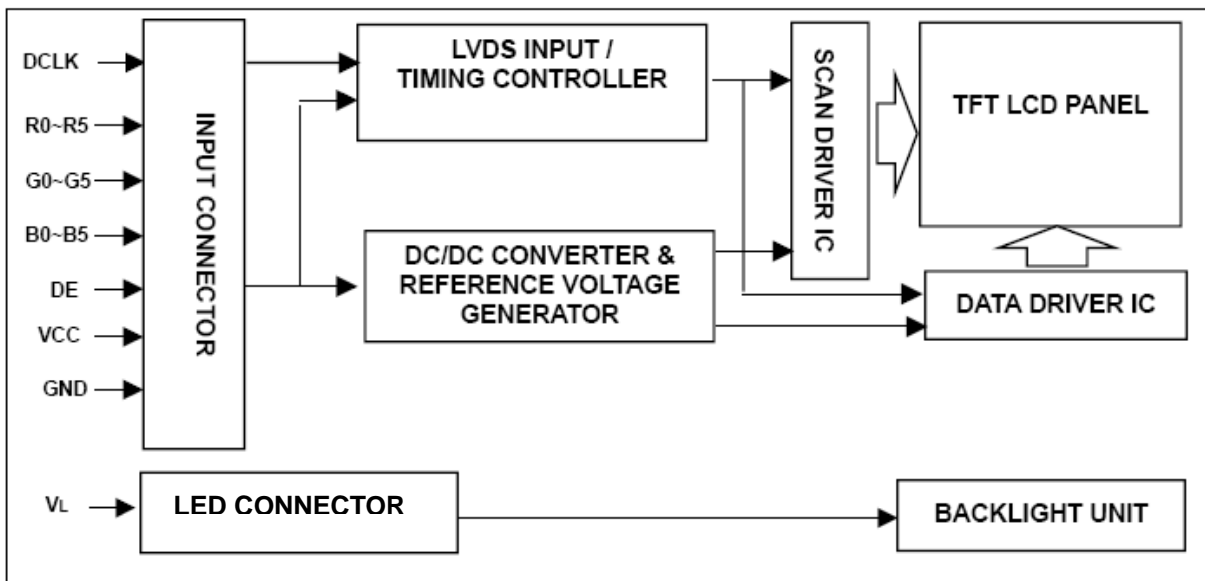

**10. QUALITY ASSURANCE**

No.	Test Items	Test Condition	REMARK
1	High Temperature Storage Test	Ta=80°C Dry 240h	
2	Low Temperature Storage Test	Ta=-30°C Dry 240h	
3	High Temperature Operation Test	Ta=70°C Dry 240h	
4	Low Temperature Operation Test	Ta=-20°C Dry 240h	
5	High Temperature and High Humidity Operation Test	Ta=60°C 90%RH 240h	
6	Electro Static Discharge Test	150pF, 330Ω, ±8KV(Contact)/±15KV(Air), 5 points/panel, 5 times/point	
7	Shock Test (non-operating)	Half sine wave, 180G, 2ms one shock of each six faces (I.e. run 180G 2ms for all six faces)	
8	Vibration Test (non-operating)	Sine wave, 10 ~ 500 ~ 10Hz, 1.5G, 0.37oct/min 3 axis, 1hour/axis	
9	Thermal Shock Test	-20°C (0.5h) ~ 70°C (0.5h) / 100 cycles(Dry)	

\*\*\*\*\* Ta= Ambient Temperature

11. OUTLINE DRAWING

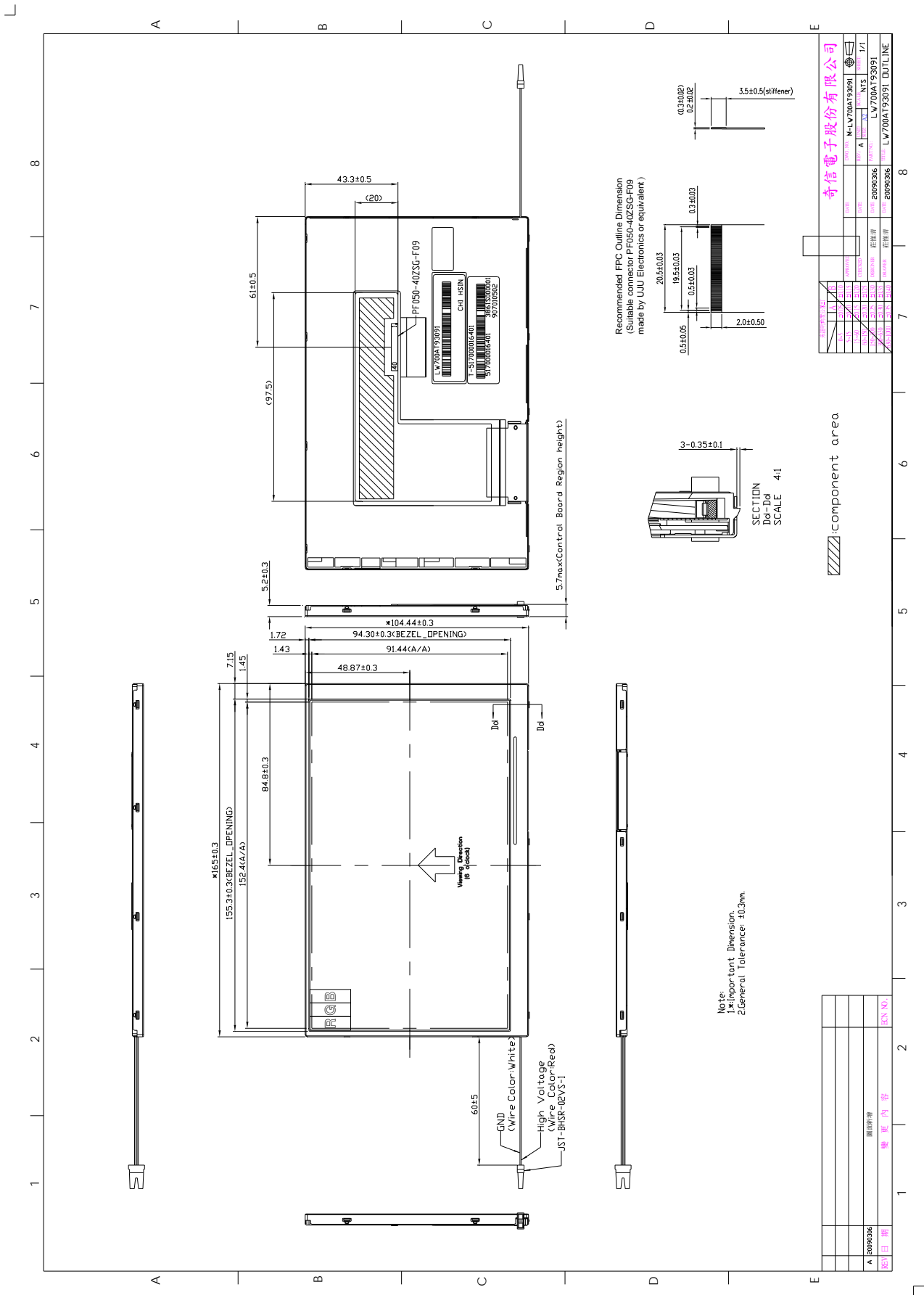

**12. PACKAGE INFORMATION**

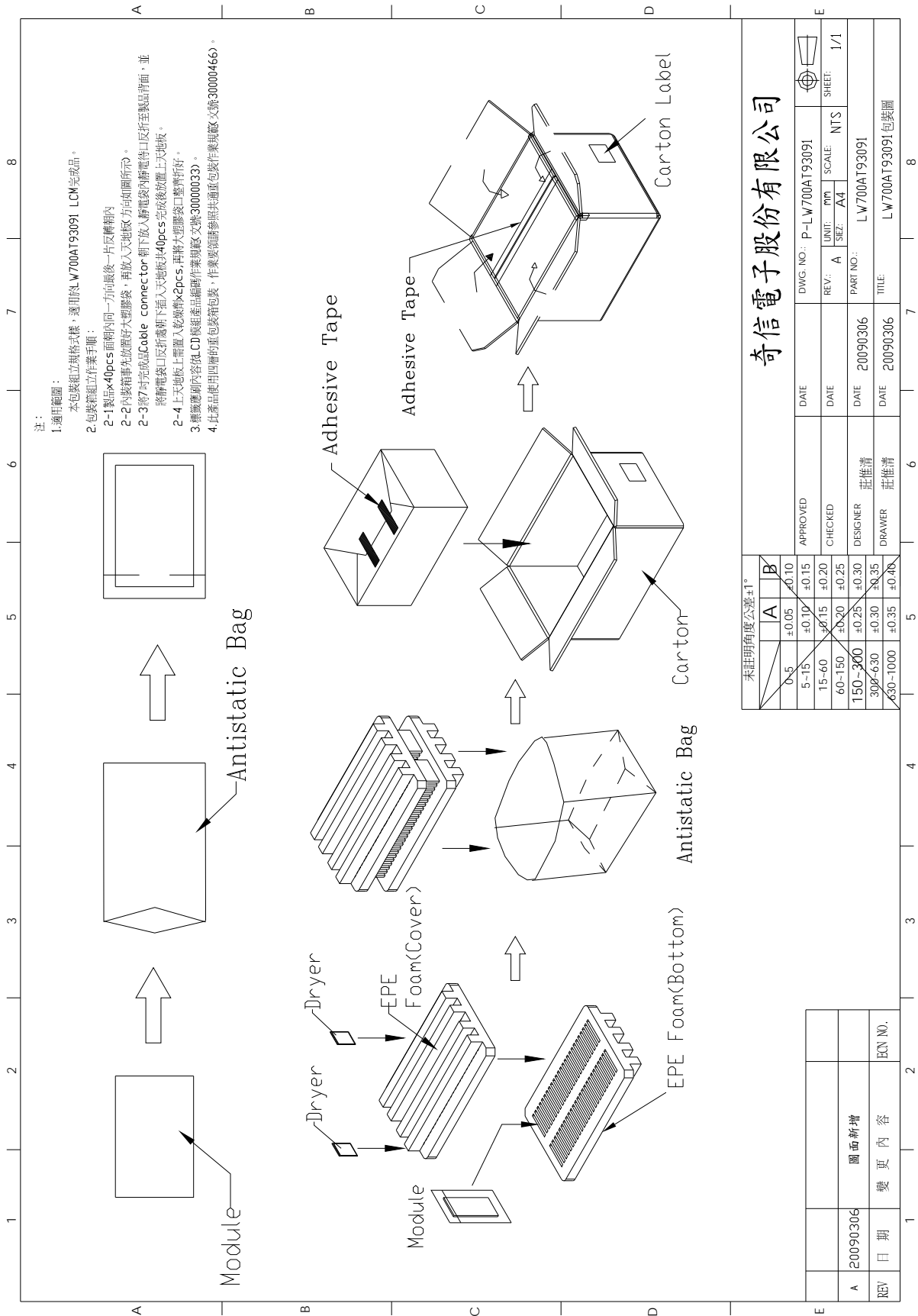

未註明角度公差: ±1°		A		B		C		D		E	
0-5	±0.05	±0.10	±0.15	±0.20	±0.25	±0.30	±0.35	±0.40	APPROVED	DATE	DWG. NO.: P-LW700AT93091
5-15	±0.10	±0.15	±0.20	±0.25	±0.30	±0.35	±0.40	CHECKED	DATE	REV.: A	UNIT: P/W
15-60	±0.15	±0.20	±0.25	±0.30	±0.35	±0.40	±0.45	DESIGNER	DATE	SCALE: A4	SHEET: 1/1
60-150	±0.20	±0.25	±0.30	±0.35	±0.40	±0.45	±0.50	DRAWER	DATE	PART NO.: LW700AT93091	
150-300	±0.25	±0.30	±0.35	±0.40	±0.45	±0.50	±0.55	DESIGNER	DATE	20090306	
300-630	±0.30	±0.35	±0.40	±0.45	±0.50	±0.55	±0.60	DRAWER	DATE	20090306	
630-1000	±0.35	±0.40	±0.45	±0.50	±0.55	±0.60	±0.65		DATE		TITLE: LW700AT93091 包裝圖

奇信電子股份有限公司

REV	日期	變更內容	ECN NO.
A	20090306	圖面新增	

## 13. PRECAUTIONS

Please pay attention to the following when you use this TFT LCD module.

### 13.1 MOUNTING PRECAUTIONS

- (1) You must mount a module using arranged in four corners or four sides.
- (2) You should consider the mounting structure so that uneven force (ex. Twisted stress) is not applied to the module.  
And the case on which a module is mounted should have sufficient strength so that external force is not transmitted directly to the module.
- (3) Please attach a transparent protective plate to the surface in order to protect the polarizer.  
Transparent protective plate should have sufficient strength in order to the resist external force.
- (4) You should adopt radiation structure to satisfy the temperature specification.
- (5) Acetic acid type and chlorine type materials for the cover case are not describe because the former generates corrosive gas of attacking the polarizer at high temperature and the latter causes circuit break by electro-chemical reaction.
- (6) Do not touch, push or rub the exposed polarizers with glass, tweezers or anything harder than HB pencil lead. And please do not rub with dust clothes with chemical treatment.  
Do not touch the surface of polarizer for bare hand or greasy cloth. (Some cosmetics are determined to the polarizer)
- (7) When the surface becomes dusty, please wipe gently with adsorbent cotton or other soft materials like chamois soaks with petroleum benzene. Normal-hexane is recommended for cleaning the adhesives used to attach front / rear polarizers. Do not use acetone, toluene and alcohol because they cause chemical damage to the polarizer.
- (8) Wipe off saliva or water drops as soon as possible. Their long time contact with polarizer causes deformations and color fading.
- (9) Do not open the case because inside circuits do not have sufficient strength.

### 13.2 OPERATING PRECAUTIONS

- (1) The spike noise causes the mis-operation of circuits. It should be lower than following voltage :  $V = \pm 200\text{mV}$  (Over and under shoot voltage)
- (2) Response time depends on the temperature. (In lower temperature, it becomes longer.)
- (3) Brightness depends on the temperature. (In lower temperature, it becomes lower)  
And in lower temperature, response time (required time that brightness is stable after turned on) becomes longer.
- (4) Be careful for condensation at sudden temperature change. Condensation makes damage to polarizer or electrical contacted parts. And after fading condensation, smear or spot will occur.
- (5) When fixed patterns are displayed for a long time, remnant image is likely to occur.
- (6) Module has high frequency circuits. Sufficient suppression to the electromagnetic interference shall be done by system manufacturers. Grounding and shielding methods may be important to minimize the interference.

### 13.3 ELECTROSTATIC DISCHARGE CONTROL

Since a module is composed of electronic circuits, it is not strong to electrostatic discharge. Make certain that treatment persons are connected to ground through wristband etc. And don't touch interface pin directly.

### 13.4 PRECAUTIONS FOR STRONG LIGHT EXPOSURE

Strong light exposure causes degradation of polarizer and color filter.

### 13.5 STORAGE

When storing modules as spares for a long time, the following precautions are necessary.

- (1) Store them in a dark place. Do not expose the module to sunlight or fluorescent light. Keep the temperature between  $5^{\circ}\text{C}$  and  $35^{\circ}\text{C}$  at normal humidity.
- (2) The polarizer surface should not come in contact with any other object. It is recommended that they be stored in the container in which they were shipped.

**13.6 HANDLING PRECAUTIONS FOR PROTECTION FILM**

- (1) When the protection film is peeled off, static electricity is generated between the film and polarizer. This should be peeled off slowly and carefully by people who are electrically grounded and with well ion-blown equipment or in such a condition, etc.
- (2) The protection film is attached to the polarizer with a small amount of glue. Is apt to remain on the polarizer. Please carefully peel off the protection film without rubbing it against the polarizer.
- (3) When the module with protection film attached is stored for a long time, sometimes there remains a very small amount of glue still on the polarizer after the protection film is peeled off.
- (4) You can remove the glue easily. When the glue remains on the polarizer surface or its vestige is recognized, please wipe them off with absorbent cotton waste or other soft material like chamois soaked with normal-hexane.

CHI HSIN CONFIDENTIAL-FOR REVIEW ONLY