



ELECTRONICS

Approval



TO :
DATE : Dec.5. 2008

SAMSUNG TFT-LCD
MODEL NO : LTN156AT01-D

NOTE : Extension code [-D]
 → LTN156AT01-D
 Surface type [Glare]

The information described in this SPEC is preliminary and can be changed without prior notice.

APPROVED BY : K. H. Shin

PREPARED BY : Mobile Division, Application Engineering Part

SAMSUNG ELECTRONICS CO., LTD.



Samsung Secret

Doc.No.	LTN156AT01-D	Rev.No	04-A00-S-081125	Page	1 / 30
----------------	--------------	---------------	-----------------	-------------	--------

CONTENTS

Revision History	----- (3)
General Description	----- (4)
1. Absolute Maximum Ratings	----- (5)
1.1 Absolute Ratings of environment	
1.2 Electrical Absolute Ratings	
2. Optical Characteristics	----- (7)
3. Electrical Characteristics	----- (10)
3.1 TFT LCD Module	
3.2 Backlight Unit	
3.3 LED Driver	
4. Block Diagram	----- (13)
4.1 TFT LCD Module	
5. Input Terminal Pin Assignment	----- (14)
5.1 Input Signal & Power	
5.2 LVDS Interface	
5.3 Timing Diagrams of LVDS For Transmitting	
5.4 Input Signals, Basic Display Colors and Gray Scale of Each Color.	
5.5 Pixel format	
6. Interface Timing	----- (19)
6.1 Timing Parameters	
6.2 Timing Diagrams of interface Signal	
6.3 Power ON/OFF Sequence	
7. Outline Dimension	----- (21)
8. Packing	----- (23)
9. Markings & Others	----- (24)
10. General Precautions	----- (26)
11. EDID	----- (28)

Samsung Secret

GENERAL DESCRIPTION

DESCRIPTION

LTN156AT01-D is a color active matrix TFT (Thin Film Transistor) liquid crystal display (LCD) that uses amorphous silicon TFT as switching devices. This model is composed of a TFT LCD panel, a driver circuit and a backlight system. The resolution of a 15.6" contains 1366 x 768 pixels and can display up to 262,144 colors. 6 O'clock direction is the Optimum viewing angle.

FEATURES

- Thin and light weight
- High contrast ratio, high aperture structure
- 1366 x 768 pixels resolution (16:9)
- Fast Response Time
- Low power consumption
- DE (Data enable) only mode
- 3.3V LVDS Interface
- On board EDID chip
- Pb-free product
- RoHS compliance

APPLICATIONS

- Notebook PC
- If the usage of this product is not for PC application, but for others, please contact SEC

GENERAL INFORMATION

Item	Specification	Unit	Note
Display area	344.232 (H) x 193.536 (V) (15.6"diagonal)	mm	
Driver element	a-Si TFT active matrix		
Display colors	262,144		
Number of pixel	1366 x 768	pixel	16 : 9
Pixel arrangement	RGB vertical stripe		
Pixel pitch	0.252 (H) x 0.252 (V) (TYP.)	mm	
Display Mode	Normally white		
Surface treatment	Haze 0, Hardness 3H		Glare

Samsung Secret

Doc.No.	LTN156AT01-D	Rev.No	04-A00-S-081125	Page	4 / 30
----------------	--------------	---------------	-----------------	-------------	--------

Mechanical Information

Item		Min.	Typ.	Max.	Unit	Note
Module size	Horizontal (H)	358.8	359.3	359.8	mm	
	Vertical (V)	209.0	209.5	210	mm	
	Depth (D)	-	-	6.2	mm	(1)
Weight		-	500	520	g	

Note (1) Measurement condition of outline dimension

- . Equipment : Vernier Calipers
- . Push Force : 500g · f (minimum)

1. ABSOLUTE MAXIMUM RATINGS

1.1 ENVIRONMENTAL ABSOLUTE RATINGS

Item	Symbol	Min.	Max.	Unit	Note
Storage temperate	TSTG	-20	60	°C	(1), (5)
Operating temperate (Temperature of glass surface)	TOPR	0	50	°C	(1), (5)
Shock (non-operating)	Snop	-	240	G	(2), (4)
Vibration (non-operating)	Vnop	-	2.41	G	(3), (4)

Note (1) Temperature and relative humidity range are shown in the figure below.

95 % RH Max. ($40\text{ }^{\circ}\text{C} \geq T_a$)

Maximum wet - bulb temperature at $39\text{ }^{\circ}\text{C}$ or less. ($T_a > 40\text{ }^{\circ}\text{C}$) No condensation

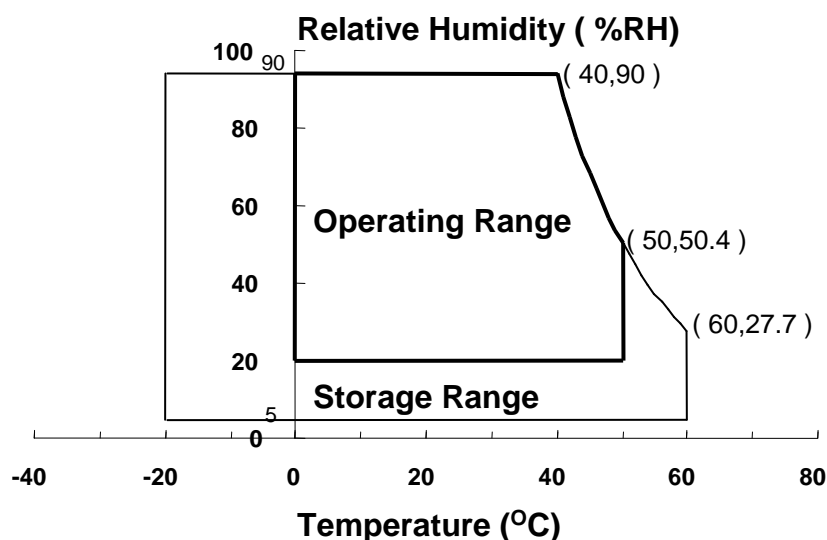

(2) 2ms, half sine wave, one time for $\pm X$, $\pm Y$, $\pm Z$.

(3) 5 - 500 Hz, random vibration, 30min for X, Y, Z.

(4) At testing Vibration and Shock, the fixture in holding the Module to be tested have to be hard and rigid enough so that the Module would not be twisted or bent by the fixture.

(5) If product is used for extended time excessively or exposed to high temperatures for extended time, there is a possibility of wide viewing angle film damage which could affect visual characteristics.

Samsung Secret

Doc.No.	LTN156AT01-D	Rev.No	04-A00-S-081125	Page	5 / 30
---------	--------------	--------	-----------------	------	--------

1.2 ELECTRICAL ABSOLUTE RATINGS

(1) TFT LCD MODULE

 $V_{DD} = 3.3V, V_{SS} = GND = 0V$

Item	Symbol	Min.	Max.	Unit	Note
Power Supply Voltage	V_{DD}	$V_{DD} - 0.3$	$V_{DD} + 0.3$	V	(1)
Logic Input Voltage	V_{DD}	$V_{DD} - 0.3$	$V_{DD} + 0.3$	V	(1)

Note (1) Within T_a ($25 \pm 2 \text{ }^\circ\text{C}$)

(2) BACK-LIGHT UNIT

 $T_a = 25 \pm 2 \text{ }^\circ\text{C}$

Item	Symbol	Min.	Max.	Unit	Note
Lamp Current	I_L	2.0	6.5	mArms	(1)
Lamp frequency	F_L	50	80	kHz	(1)

Note 1) Permanent damage to the device may occur if maximum values are exceeded
 Functional operation should be restricted to the conditions described under normal operating conditions.

Samsung Secret

2. OPTICAL CHARACTERISTICS

The following items are measured under stable conditions. The optical characteristics should be measured in a dark room or equivalent state with the methods shown in Note (5).
Measuring equipment : TOPCON SR-3

* Ta = 25 ± 2 °C, V_{DD}=3.3V, f_V= 60Hz, f_{DCLK}= 72.33 MHz, I_L = 6.5 mA

Item		Symbol	Condition	Min.	Typ.	Max	Unit	Note
Contrast Ratio (5 Points)		CR	Normal Viewing Angle φ = 0 θ = 0	500	600	-	-	(1), (2), (5)
Response Time at Ta (Rising + Falling)		T _{RT}		-	25	35	msec	(1), (3)
Average Luminance of White (5 Points)		Y _{L,AVE}		200	220	-	cd/m ²	I _L =6.0 mA (1), (4)
Color Chromaticity (CIE)	Red	R _X		0.609	0.629	0.649	-	
		R _Y		0.313	0.333	0.353		
	Green	G _X		0.272	0.292	0.312		
		G _Y		0.560	0.580	0.600		
	Blue	B _X		0.140	0.160	0.180		
		B _Y		0.076	0.096	0.116		
	White	W _X		0.293	0.313	0.333		
		W _Y	0.309	0.329	0.349			
Viewing Angle	Hor.	θ _L	CR ≥ 10	40	-	-	Degrees	(1), (5) SR-3
		θ _R		40	-	-		
	Ver.	φ _H		15	-	-		
		φ _L		30	-	-		
Color Gamut				-	60	-	%	
13 Points White Variation		Δ _L		-	-	1.7	-	(6)

Samsung Secret

Note 1) Definition of Viewing Angle : Viewing angle range($10 \leq C/R$)

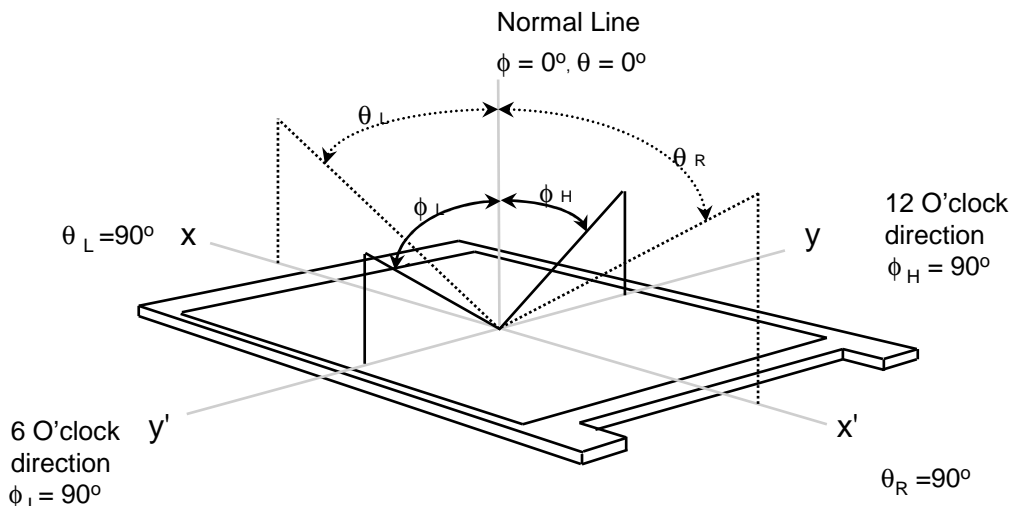

Note 2) Definition of Contrast Ratio (CR) : Ratio of gray max (Gmax) ,gray min (Gmin) at 5 points(4, 5, 7, 9, 10)

$$CR = \frac{CR(4) + CR(5) + CR(7) + CR(9) + CR(10)}{5}$$

Points : (4) , (5) , (7) , (9) , (10) at the figure of Note (6).

Note 3) Definition of Response time :

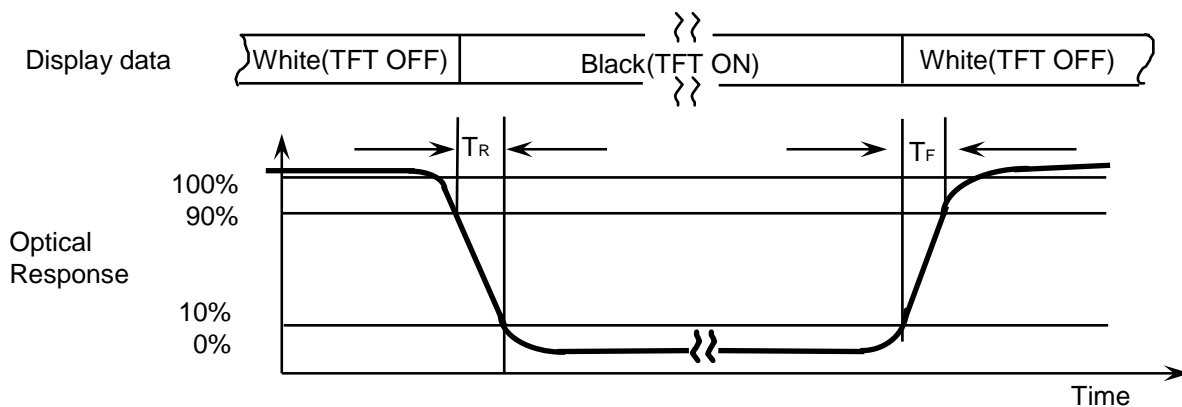

Note 4) Definition of Average Luminance of White : measure the luminance of white at 5 points.

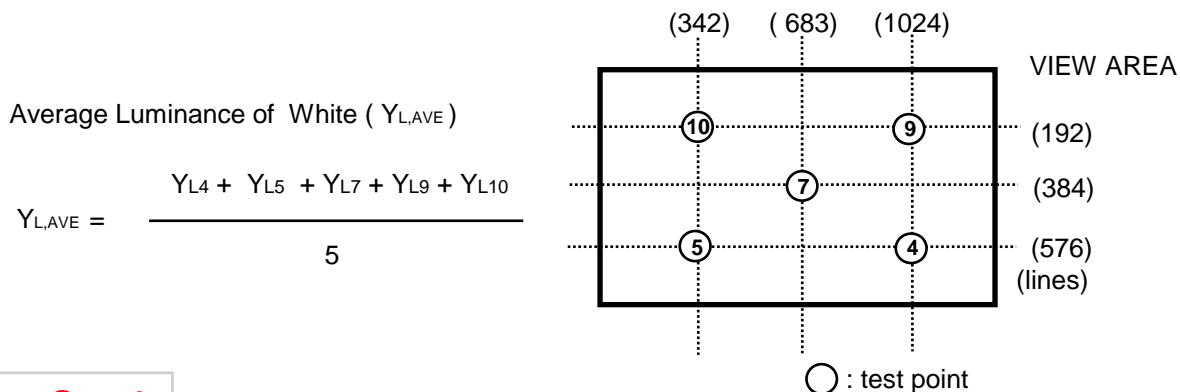

Samsung Secret

Note 5) After stabilizing and leaving the panel alone at a given temperature for 30 min , the measurement should be executed. Measurement should be executed in a stable, windless, and dark room. 30 min after lighting the backlight. This should be measured in the center of screen.
 Lamp current : 6.5 mA (Inverter : S11700)
 Environment condition : $T_a = 25 \pm 2 \text{ }^\circ\text{C}$

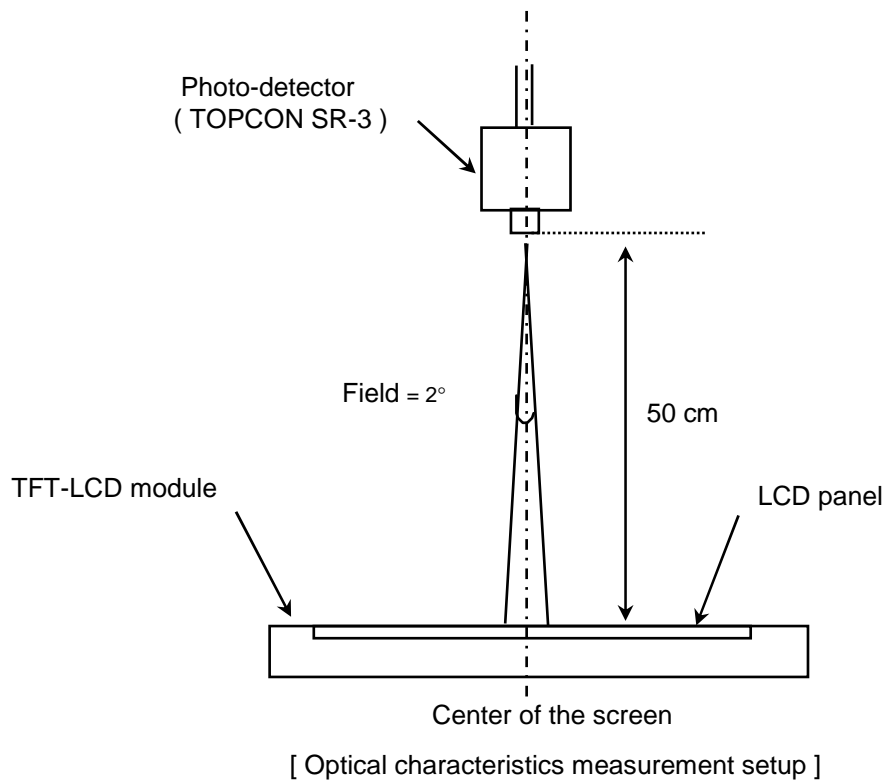

Note 6) Definition of 13 points white variation (δL), [① ~ ⑬]

$$\delta L = \frac{\text{Maximum luminance of 13 points}}{\text{Minimum luminance of 13 points}}$$

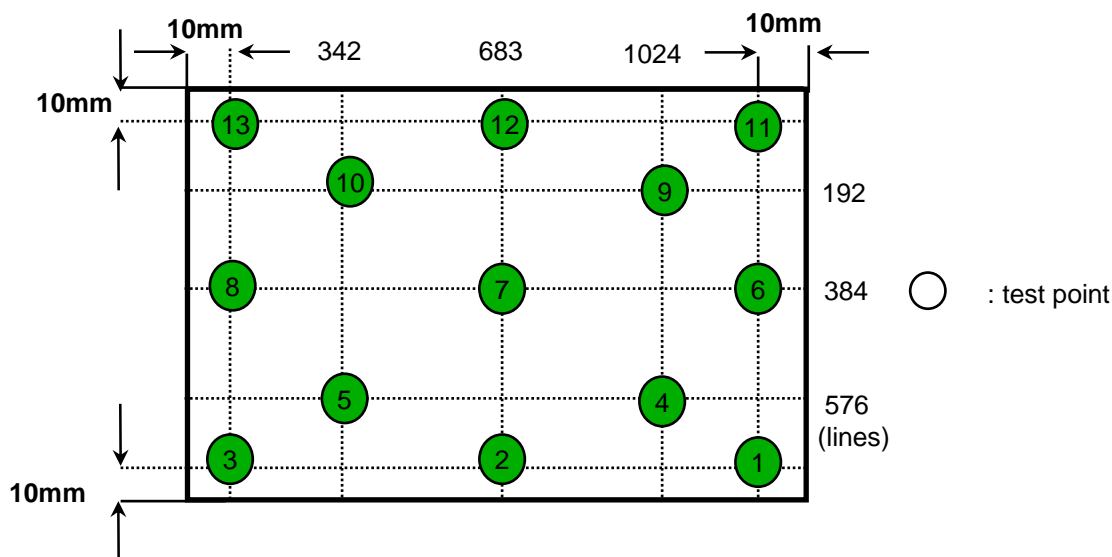

Samsung Secret

3. ELECTRICAL CHARACTERISTICS

3.1 TFT LCD MODULE

 $T_a = 25 \pm 2^\circ\text{C}$

Item	Symbol	Min.	Typ.	Max.	Unit	Note	
Voltage of Power Supply	V_{DD}	3.0	3.3	3.6	V		
Differential Input Voltage for LVDS Receiver Threshold	High	V_{IH}	-	-	+100	mV	$V_{CM} = +1.2V$
	Low	V_{IL}	-100	-	-	mV	
Vsync Frequency	f_V	-	60	-	Hz		
Hsync Frequency	f_H	-	47.4	-	KHz		
Main Frequency	f_{DCLK}	67.5	72.33	80	MHz		
Rush Current	I_{RUSH}	-	-	1.5	A	(4)	
Current of Power Supply	White	I_{DD}	-	360	-	mA	(2),(3)*a
	Mosaic		-	420	-	mA	(2),(3)*b
	V. Stripe		-	530	600	mA	(2),(3)*c

Note (1) Display data pins and timing signal pins should be connected. (GND = 0V)

(2) $f_V = 60\text{Hz}$, $f_{DCLK} = 72.33\text{ MHz}$, $V_{DD} = 3.3V$, DC Current.

(3) Power dissipation pattern

*a) White Pattern

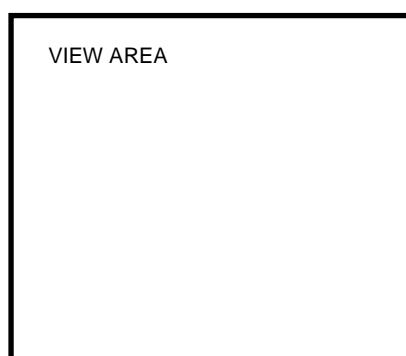

*b) Mosaic Pattern

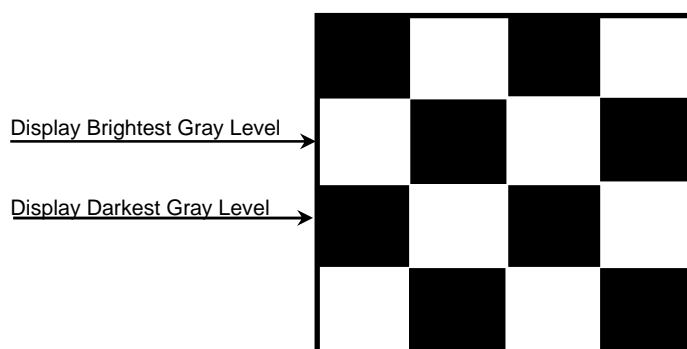

Samsung Secret

*c) 1dot Vertical stripe pattern

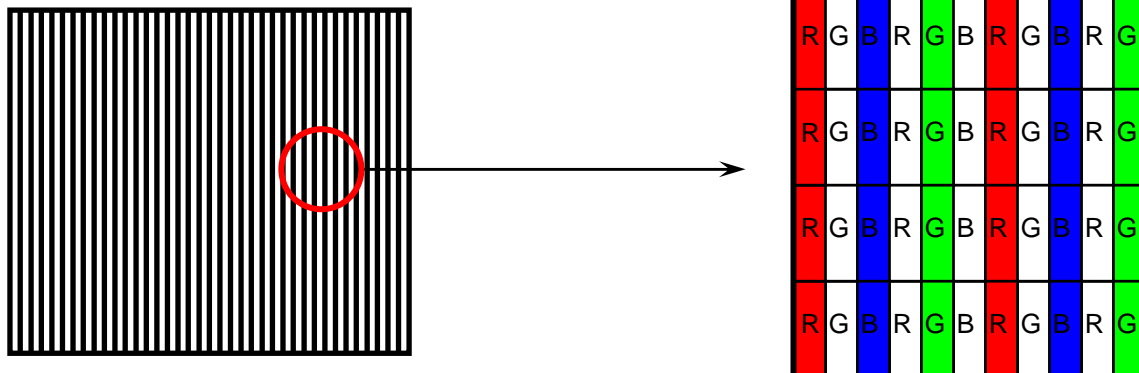

4) Rush current measurement condition

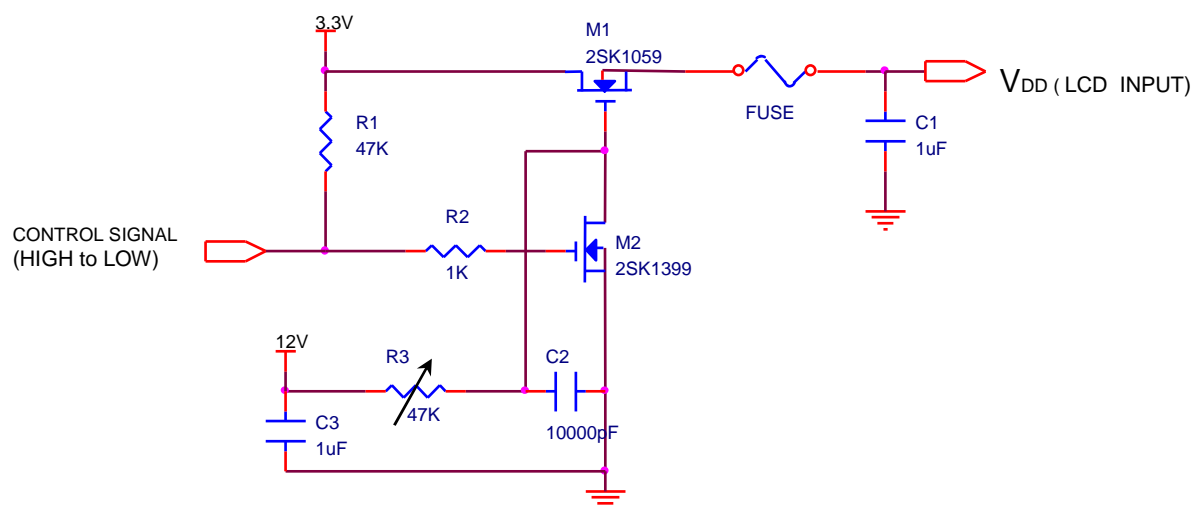

V_{DD} rising time is 470us

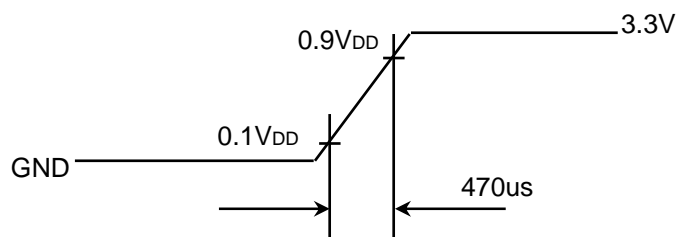

Samsung Secret

3.2 BACK-LIGHT UNIT

The backlight system is an edge-lighting type with a CCFL (Cold Cathode Fluorescent Lamp).
The characteristics of a single lamp are shown in the following tables.

- INVERTER : (SEM SI 1700)

Ta= 25 ± 2 °C

Item	Symbol	Min.	Typ.	Max.	Unit	Note
Lamp Current	I _L	3.0	6.0	6.5	mArms	(1)
Lamp Voltage	V _L	-	705	-	Vrms	I _L =6.0mA
Frequency	f _L	48	60	65	KHz	(2)
Power Consumption	P _L	-	4.5	-	W	(3) I _L =6.0mA
Operating Life Time	Hr	15,000	-	-	Hour	(4)
Startup Voltage	V _s	-	-	1300	Vrms	25°C, (5)
				1480	Vrms	0°C, (5)
Lamp startup time		-	-	1.0	sec	(5)

Note) The waveform of the inverter output voltage must be area symmetric and the design of the inverter must have specifications for the modularized lamp.

The performance of the backlight, for example life time or brightness, is much influenced by the characteristics of the DC-AC inverter for the lamp. So all the parameters of an inverter should be carefully designed so as not to produce too much leakage current from high-voltage output of the inverter. When you design or order the inverter, please make sure that a poor lighting caused by the mismatch of the backlight and the inverter(miss lighting, flicker, etc.) never occur. When you confirm it, the module should be operated in the same condition as it is installed in your instrument.

Note (1) Lamp current is measured with a high frequency current meter as shown below.

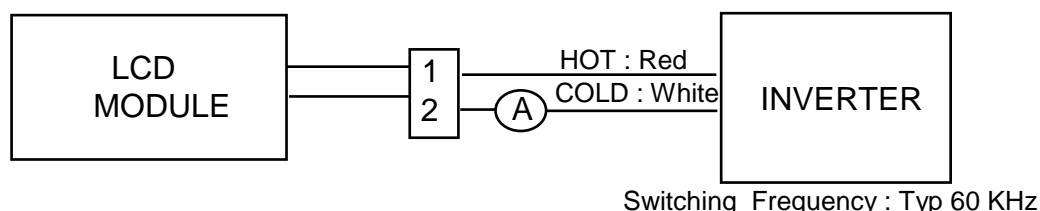

- (2) Lamp frequency may produce interference with horizontal synchronous frequency and this may cause line flow on the display. Therefore lamp frequency should be detached from the horizontal synchronous frequency and its harmonics as far as possible in order to avoid interference.
- (3) Refer to I_L × V_L to calculate.
- (4) Life time (Hr) of a lamp can be defined as the time in which it continues to operate under the condition Ta= 25 ± 2 °C and I_L = 6.5 mArms until one of the following event occurs.
 1. When the brightness becomes 50% or lower than the original.
 2. When the Effective ignition length becomes 80% or lower than the original value.
(Effective ignition length is defined as an area that has less than 70% brightness compared to the brightness in the center point.)
- (5) The inverter open voltage - this voltage should be measured after ballast capacitor- have to be larger than the lamp startup voltage, otherwise backlight may has blinking for a moment after turns on or not be turned on.
If an inverter has shutdown function it should keep its open voltage for longer than 1 second even if lamp connector open.

Samsung Secret

Doc.No.	LTN156AT01-D	Rev.No	04-A00-S-081125	Page	12 / 30
---------	--------------	--------	-----------------	------	---------

4. BLOCK DIAGRAM

4.1 TFT LCD Module

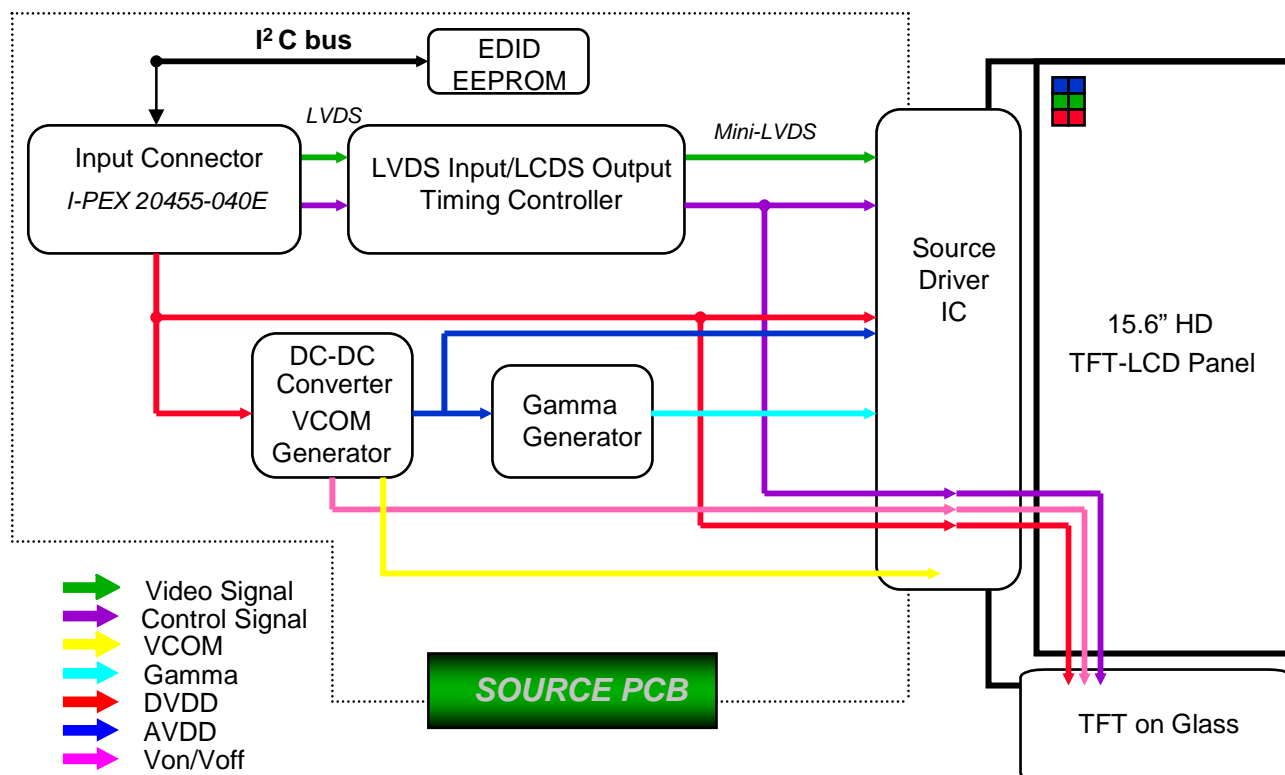

4.2 BACK-LIGHT UNIT

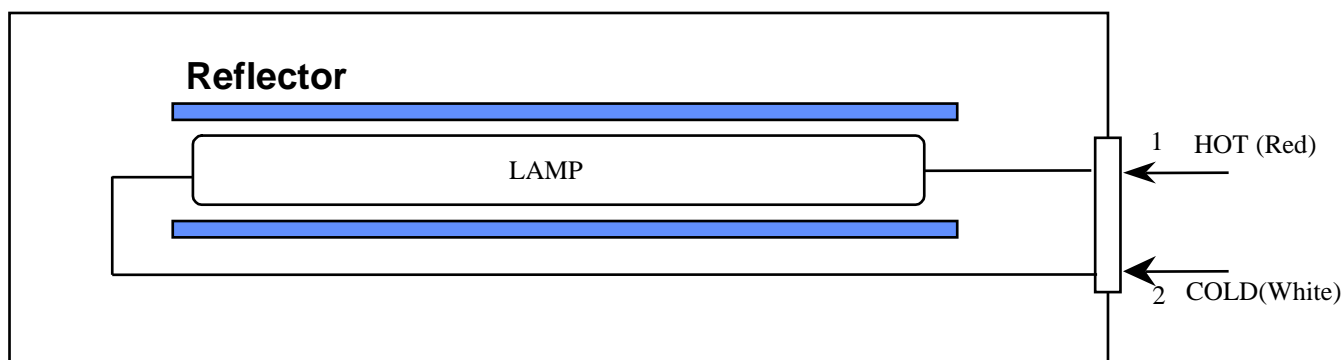

Note) The output of the inverter may change according to the material of the reflector.

Samsung Secret

5. INPUT TERMINAL PIN ASSIGNMENT

5.1. Input Signal & Power (LVDS, Connector : UJU IS100-L30R-C15 or compatible)
Mating Connector : JAE FI-X30M or compatible)

PIN NO	SYMBOL	FUNCTION	POLARITY	REMARK
1	VSS	Ground		
2	VDD	POWER SUPPLY +3.3V		
3	VDD	POWER SUPPLY +3.3V		
4	VEEDID	DDC 3.3V Power		
5	TEST	Panel Self Test		
6	CLKEDID	DDC Clock		
7	DATAEDID	DDC data		
8	RxIN0-	LVDS Differential Data INPUT (R0-R5,G0)	Negative	
9	RxIN0+	LVDS Differential Data INPUT (R0-R5,G0)	Positive	
10	VSS	Ground		
11	RxIN1-	LVDS Differential Data INPUT (G1-G5,B0-B1)	Negative	
12	RxIN1+	LVDS Differential Data INPUT (G1-G5,B0-B1)	Positive	
13	VSS	Ground		
14	RxIN2-	LVDS Differential Data INPUT (B2-B5,Sync,DE)	Negative	
15	RxIN2+	LVDS Differential Data INPUT (B2-B5,Sync,DE)	Positive	
16	VSS	Ground		
17	RxCLK-	LVDS Differential Data INPUT (Clock)	Negative	
18	RxCLK+	LVDS Differential Data INPUT (Clock)	Positive	
19	VSS	Ground		
20	NC	No Connection		
21	NC	No Connection		
22	NC	No Connection		
23	NC	No Connection		
24	NC	No Connection		
25	NC	No Connection		
26	NC	No Connection		
27	NC	No Connection		
28	NC	No Connection		
29	NC	No Connection		
30	NC	No Connection		

Samsung Secret

5.2 LVDS Interface : Transmitter DS90CF363 or Compatible

Pin No.	Name	RGB Signal	Pin No.	Name	RGB Signal
51	TxIN0	R0	14	TxIN14	G5
52	TxIN1	R1	15	TxIN15	B0
54	TxIN2	R2	19	TxIN18	B1
55	TxIN3	R3	20	TxIN19	B2
56	TxIN4	R4	22	TxIN20	B3
3	TxIN6	R5	23	TxIN21	B4
4	TxIN7	G0	24	TxIN22	B5
6	TxIN8	G1	27	TxIN24	Hsync
7	TxIN9	G2	28	TxIN25	Vsync
11	TxIN12	G3	30	TxIN26	DE
12	TxIN13	G4	31	TxCLKIN	Clock

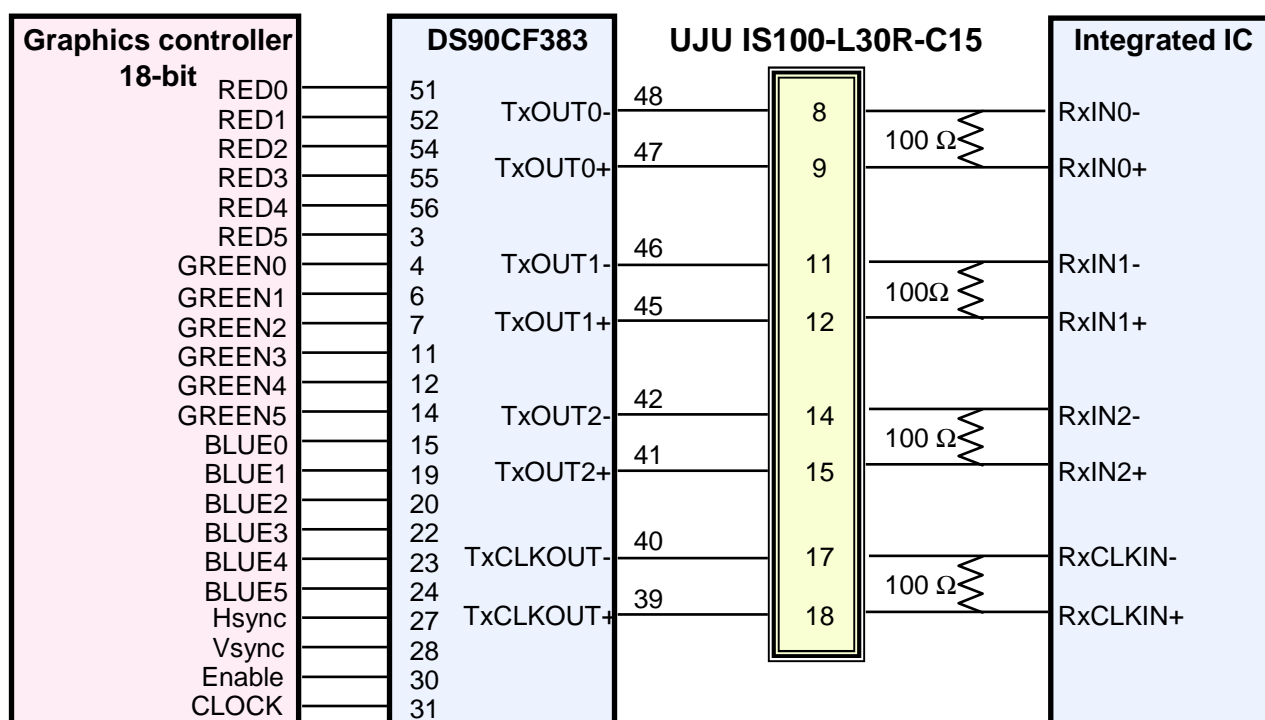
LVDS INTERFACE

Note : The LCD Module uses a 100ohm resistor between positive and negative lines of each receiver input.

Samsung Secret

5.3 Timing Diagrams of LVDS For Transmission

LVDS Receiver : Integrated T-CON

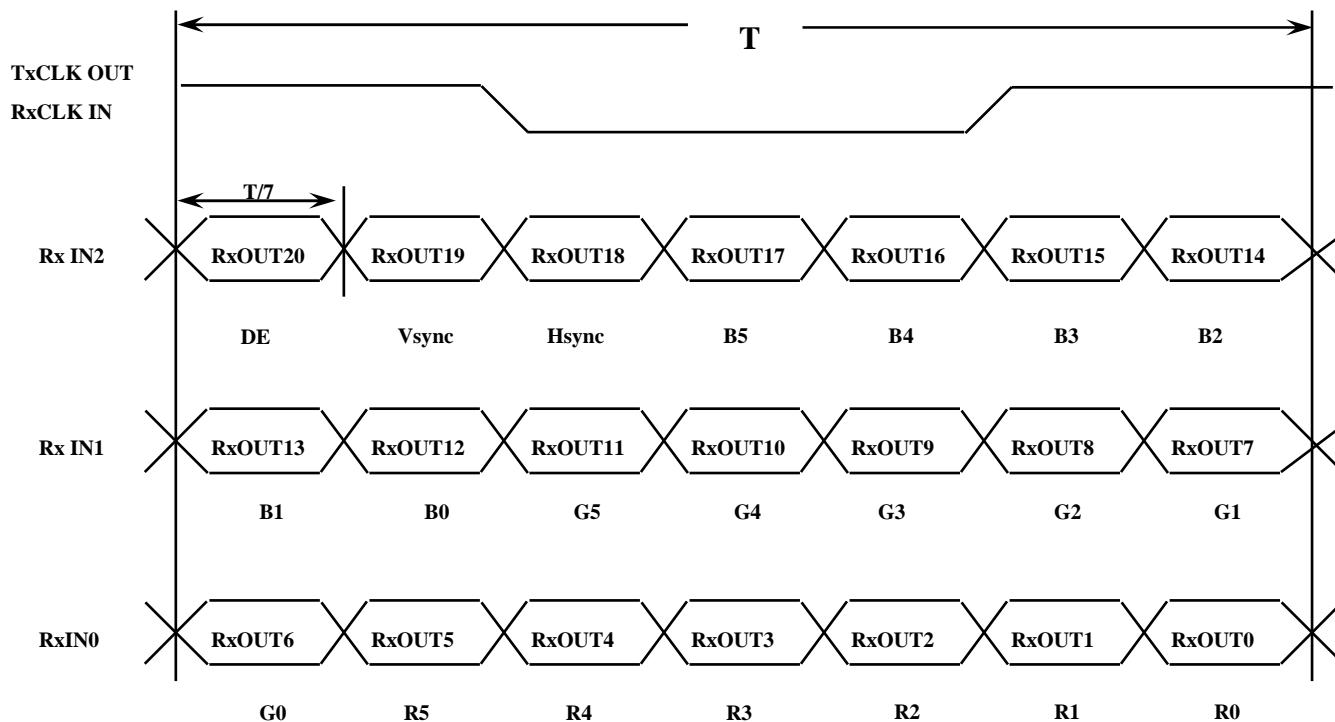

Samsung Secret

5.4 Input Signals, Basic Display Colors and Gray Scale of Each Color

Color	Display	Data Signal																Gray Scale Level	
		Red					Green					Blue							
		R0	R1	R2	R3	R4	R5	G0	G1	G2	G3	G4	G5	B0	B1	B2	B3		45
Basic Colors	Black	0	0	0	0	0	0	0	0	0	0	0	0	0	0	0	0	0	-
	Blue	0	0	0	0	0	0	0	0	0	0	0	0	1	1	1	1	1	-
	Green	0	0	0	0	0	0	1	1	1	1	1	1	0	0	0	0	0	-
	Cyan	0	0	0	0	0	0	1	1	1	1	1	1	1	1	1	1	1	-
	Red	1	1	1	1	1	1	0	0	0	0	0	0	0	0	0	0	0	-
	Magenta	1	1	1	1	1	1	0	0	0	0	0	0	1	1	1	1	1	-
	Yellow	1	1	1	1	1	1	1	1	1	1	1	1	0	0	0	0	0	-
	White	1	1	1	1	1	1	1	1	1	1	1	1	1	1	1	1	1	-
Gray Scale Of Red	Black	0	0	0	0	0	0	0	0	0	0	0	0	0	0	0	0	0	R0
	Dark	1	0	0	0	0	0	0	0	0	0	0	0	0	0	0	0	0	R1
	↑	0	1	0	0	0	0	0	0	0	0	0	0	0	0	0	0	0	R3~R60
	:	:	:	:	:	:	:	:	:	:	:	:	:	:	:	:	:	:	
	:	:	:	:	:	:	:	:	:	:	:	:	:	:	:	:	:	:	
	↓	1	0	1	1	1	1	0	0	0	0	0	0	0	0	0	0	0	R61
	Light	0	1	1	1	1	1	0	0	0	0	0	0	0	0	0	0	0	R62
	Red	1	1	1	1	1	1	0	0	0	0	0	0	0	0	0	0	0	R63
Gray Scale Of Green	Black	0	0	0	0	0	0	0	0	0	0	0	0	0	0	0	0	0	G0
	Dark	0	0	0	0	0	0	1	0	0	0	0	0	0	0	0	0	0	G1
	↑	0	0	0	0	0	0	0	1	0	0	0	0	0	0	0	0	0	G3~G60
	:	:	:	:	:	:	:	:	:	:	:	:	:	:	:	:	:	:	
	:	:	:	:	:	:	:	:	:	:	:	:	:	:	:	:	:	:	
	↓	0	0	0	0	0	0	1	0	1	1	1	1	0	0	0	0	0	G61
	Light	0	0	0	0	0	0	0	1	1	1	1	1	0	0	0	0	0	G62
	Green	0	0	0	0	0	0	1	1	1	1	1	1	0	0	0	0	0	G63
Gray Scale Of Blue	Black	0	0	0	0	0	0	0	0	0	0	0	0	0	0	0	0	0	B0
	Dark	0	0	0	0	0	0	0	0	0	0	0	0	1	0	0	0	0	B1
	↑	0	0	0	0	0	0	0	0	0	0	0	0	0	1	0	0	0	B3~B60
	:	:	:	:	:	:	:	:	:	:	:	:	:	:	:	:	:	:	
	:	:	:	:	:	:	:	:	:	:	:	:	:	:	:	:	:	:	
	↓	0	0	0	0	0	0	0	0	0	0	0	0	1	0	1	1	1	B61
	Light	0	0	0	0	0	0	0	0	0	0	0	0	0	1	1	1	1	B62
	Blue	0	0	0	0	0	0	0	0	0	0	0	0	1	1	1	1	1	B63

Note 1) Definition of gray :

Rn: Red gray, Gn: Green gray, Bn: Blue gray (n=gray level)

Note 2) Input signal: 0 =Low level voltage, 1=High level voltage

Samsung Secret

5.5 Pixel Format in the display

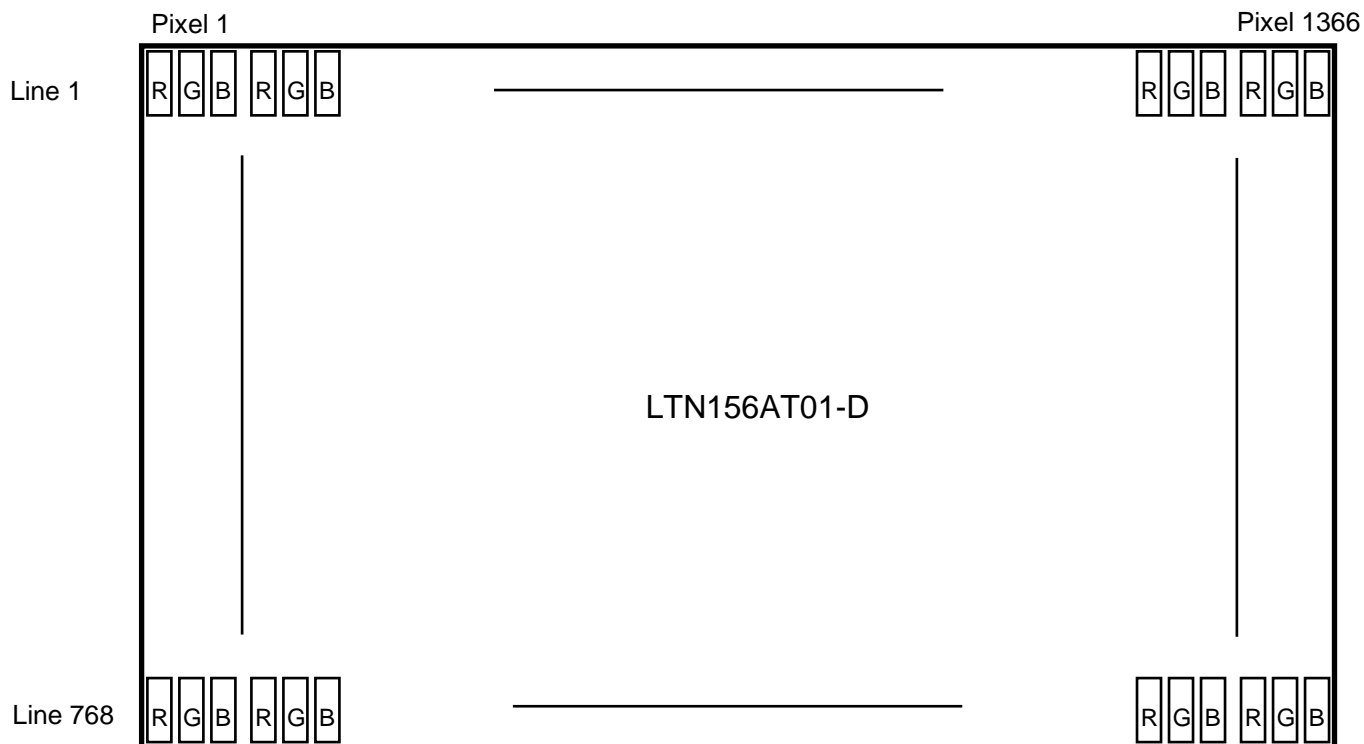

Samsung Secret

6. INTERFACE TIMING

6.1 Timing Parameters

Signal	Item	Symbol	Min.	Typ.	Max.	Unit	Note
Frame Frequency	Cycle	TV	773	790	1000	Lines	-
Vertical Active Display Term	Display Period	TVD	-	768	-	Lines	-
One Line Scanning Time	Cycle	TH	1406	1526	1750	Clocks	-
Horizontal Active Display Term	Display Period	THD	-	1366	-	Clocks	-

6.2 Timing diagrams of interface signal

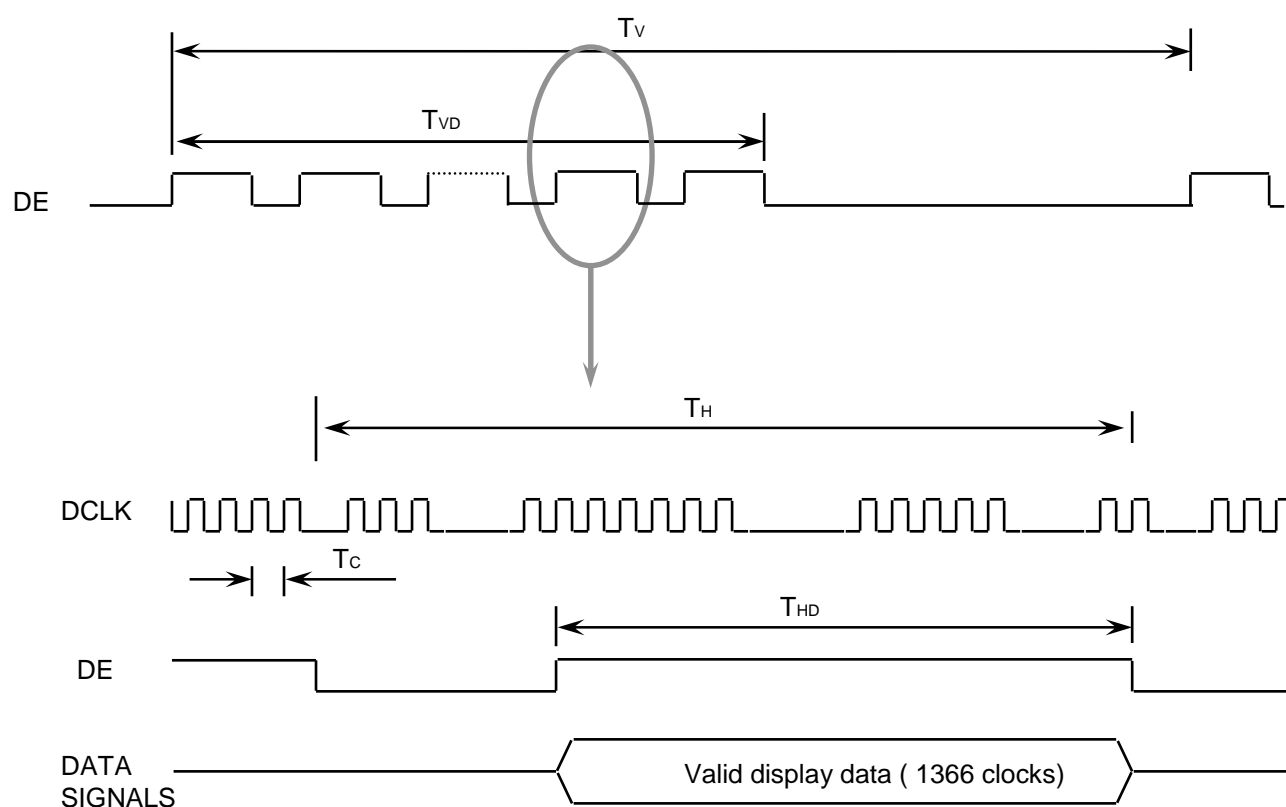

Samsung Secret

6.3 Power ON/OFF Sequence

Approval

: To prevent a latch-up or DC operation of the LCD module, the power on/off sequence should be as the diagram below.

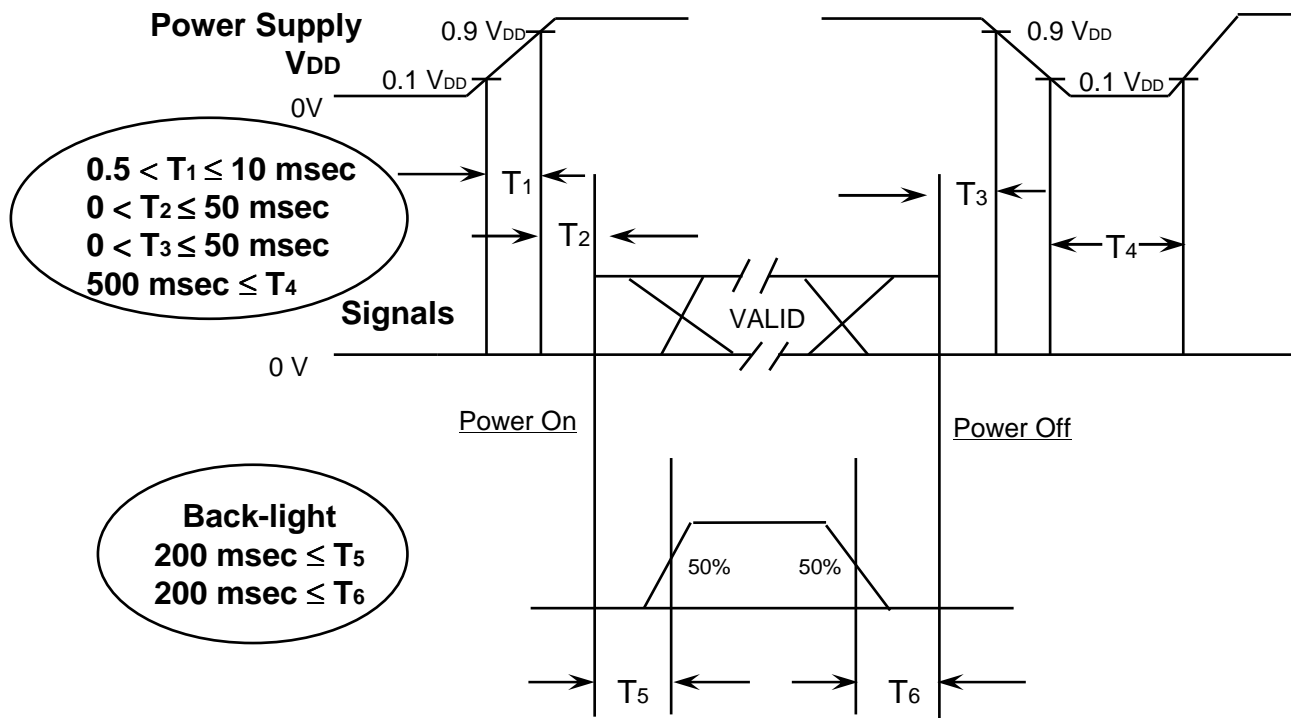

Power ON/OFF Sequence

- T1 : Vdd rising time from 10% to 90%
- T2 : The time from Vdd to valid data at power ON.
- T3 : The time from valid data off to Vdd off at power Off.
- T4 : Vdd off time for Windows restart
- T5 : The time from valid data to B/L enable at power ON.
- T6 : The time from valid data off to B/L disable at power Off.

NOTE.

- (1) The supply voltage of the external system for the module input should be the same as the definition of V_{DD} .
- (2) Apply the lamp voltage within the LCD operation range. When the back-light turns on before the LCD operation or the LCD turns off before the back-light turns off, the display may momentarily become white.
- (3) In case of V_{DD} = off level, please keep the level of input signals on the low or keep a high impedance.
- (4) T4 should be measured after the module has been fully discharged between power off and on period.
- (5) Interface signal shall not be kept at high impedance when the power is on.

Samsung Secret

Doc.No.	LTN156AT01-D	Rev.No	04-A00-S-081125	Page	20 / 30
----------------	--------------	---------------	-----------------	-------------	---------

7. MECHANICAL OUTLINE DIMENSION

Approval

Please refer to the next page.

Samsung Secret

Doc.No.	LTN156AT01-D	Rev.No	04-A00-S-081125	Page	21 / 30
----------------	--------------	---------------	-----------------	-------------	---------

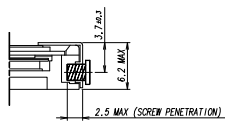
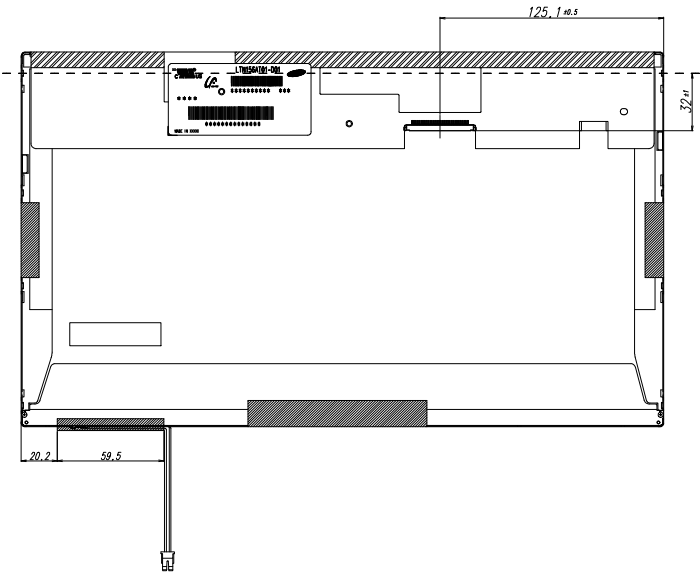
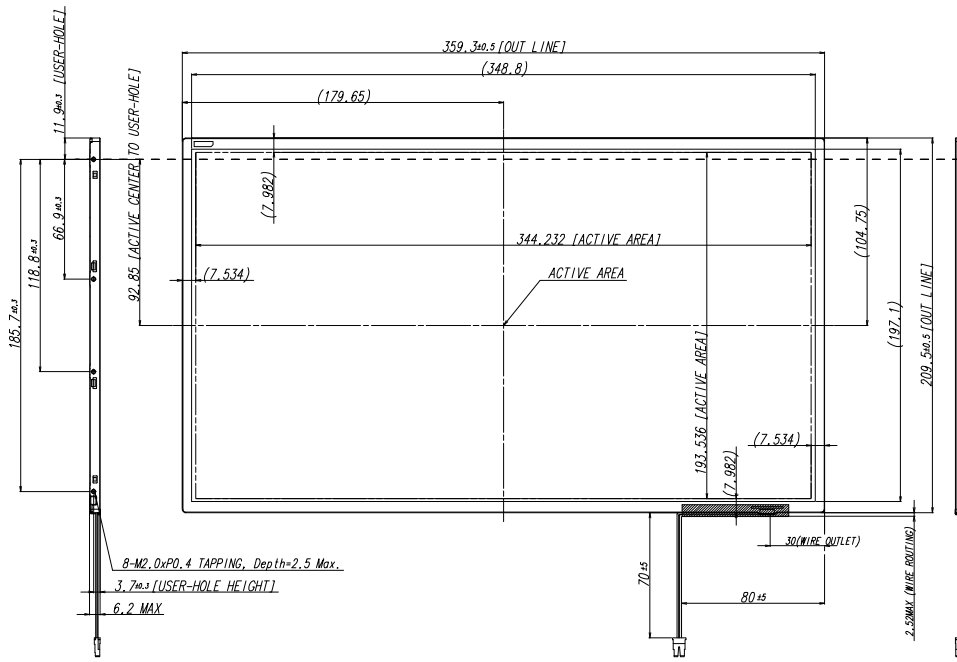

<USER HOLE SCREW PENETRATION DEPTH>

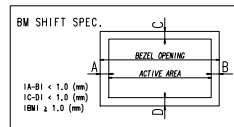

* NOTE

1. SIGNAL INTERFACE CONNECTOR TO BE SPECIFIED AS BELOW.
 - MAKER : UJU OR COMPATIBLE
 - INPUT CONNECTOR : UJU IS100-L30R-L15
2. LAMP CONNECTOR FOR BACKLIGHT TO BE SPECIFIED AS BELOW.
 - MAKER : JST (TBD)
 - PART NO : BHSR-02VS-1 (TBD)
 - LAMP DIAMETER : $\phi 2.0$
3. ALLOWED DEPTH OF USERHOLE SCREW INSERTION IS MAX 2.5mm
4. TORQUE SPEC : MAX 2.5 Kgf-cm (5TIMES)
5. CALIFERS MEASURING FORCE : 750 150 gf
6. WEIGHT : TYP 500, MAX 520 g (TBD)

Approval

REV	DATE	DESCRIPTION OF REVISION	REASON	CHG'D BY
001	11.08.2008	INITIAL DESIGN		
002	11.08.2008	DESIGN CHANGE		
003	11.08.2008	DESIGN CHANGE		
004	11.08.2008	DESIGN CHANGE		
005	11.08.2008	DESIGN CHANGE		
006	11.08.2008	DESIGN CHANGE		
007	11.08.2008	DESIGN CHANGE		
008	11.08.2008	DESIGN CHANGE		
009	11.08.2008	DESIGN CHANGE		
010	11.08.2008	DESIGN CHANGE		
011	11.08.2008	DESIGN CHANGE		
012	11.08.2008	DESIGN CHANGE		
013	11.08.2008	DESIGN CHANGE		
014	11.08.2008	DESIGN CHANGE		
015	11.08.2008	DESIGN CHANGE		
016	11.08.2008	DESIGN CHANGE		
017	11.08.2008	DESIGN CHANGE		
018	11.08.2008	DESIGN CHANGE		
019	11.08.2008	DESIGN CHANGE		
020	11.08.2008	DESIGN CHANGE		
021	11.08.2008	DESIGN CHANGE		
022	11.08.2008	DESIGN CHANGE		
023	11.08.2008	DESIGN CHANGE		
024	11.08.2008	DESIGN CHANGE		
025	11.08.2008	DESIGN CHANGE		
026	11.08.2008	DESIGN CHANGE		
027	11.08.2008	DESIGN CHANGE		
028	11.08.2008	DESIGN CHANGE		
029	11.08.2008	DESIGN CHANGE		
030	11.08.2008	DESIGN CHANGE		
031	11.08.2008	DESIGN CHANGE		
032	11.08.2008	DESIGN CHANGE		
033	11.08.2008	DESIGN CHANGE		
034	11.08.2008	DESIGN CHANGE		
035	11.08.2008	DESIGN CHANGE		
036	11.08.2008	DESIGN CHANGE		
037	11.08.2008	DESIGN CHANGE		
038	11.08.2008	DESIGN CHANGE		
039	11.08.2008	DESIGN CHANGE		
040	11.08.2008	DESIGN CHANGE		
041	11.08.2008	DESIGN CHANGE		
042	11.08.2008	DESIGN CHANGE		
043	11.08.2008	DESIGN CHANGE		
044	11.08.2008	DESIGN CHANGE		
045	11.08.2008	DESIGN CHANGE		
046	11.08.2008	DESIGN CHANGE		
047	11.08.2008	DESIGN CHANGE		
048	11.08.2008	DESIGN CHANGE		
049	11.08.2008	DESIGN CHANGE		
050	11.08.2008	DESIGN CHANGE		
051	11.08.2008	DESIGN CHANGE		
052	11.08.2008	DESIGN CHANGE		
053	11.08.2008	DESIGN CHANGE		
054	11.08.2008	DESIGN CHANGE		
055	11.08.2008	DESIGN CHANGE		
056	11.08.2008	DESIGN CHANGE		
057	11.08.2008	DESIGN CHANGE		
058	11.08.2008	DESIGN CHANGE		
059	11.08.2008	DESIGN CHANGE		
060	11.08.2008	DESIGN CHANGE		
061	11.08.2008	DESIGN CHANGE		
062	11.08.2008	DESIGN CHANGE		
063	11.08.2008	DESIGN CHANGE		
064	11.08.2008	DESIGN CHANGE		
065	11.08.2008	DESIGN CHANGE		
066	11.08.2008	DESIGN CHANGE		
067	11.08.2008	DESIGN CHANGE		
068	11.08.2008	DESIGN CHANGE		
069	11.08.2008	DESIGN CHANGE		
070	11.08.2008	DESIGN CHANGE		
071	11.08.2008	DESIGN CHANGE		
072	11.08.2008	DESIGN CHANGE		
073	11.08.2008	DESIGN CHANGE		
074	11.08.2008	DESIGN CHANGE		
075	11.08.2008	DESIGN CHANGE		
076	11.08.2008	DESIGN CHANGE		
077	11.08.2008	DESIGN CHANGE		
078	11.08.2008	DESIGN CHANGE		
079	11.08.2008	DESIGN CHANGE		
080	11.08.2008	DESIGN CHANGE		
081	11.08.2008	DESIGN CHANGE		
082	11.08.2008	DESIGN CHANGE		
083	11.08.2008	DESIGN CHANGE		
084	11.08.2008	DESIGN CHANGE		
085	11.08.2008	DESIGN CHANGE		
086	11.08.2008	DESIGN CHANGE		
087	11.08.2008	DESIGN CHANGE		
088	11.08.2008	DESIGN CHANGE		
089	11.08.2008	DESIGN CHANGE		
090	11.08.2008	DESIGN CHANGE		
091	11.08.2008	DESIGN CHANGE		
092	11.08.2008	DESIGN CHANGE		
093	11.08.2008	DESIGN CHANGE		
094	11.08.2008	DESIGN CHANGE		
095	11.08.2008	DESIGN CHANGE		
096	11.08.2008	DESIGN CHANGE		
097	11.08.2008	DESIGN CHANGE		
098	11.08.2008	DESIGN CHANGE		
099	11.08.2008	DESIGN CHANGE		
100	11.08.2008	DESIGN CHANGE		

8. PACKING

1. CARTON(Internal Package)

(1) Packing Form

Corrugated Cardboard box and Corrupad form as shock absorber

(2) Packing Method

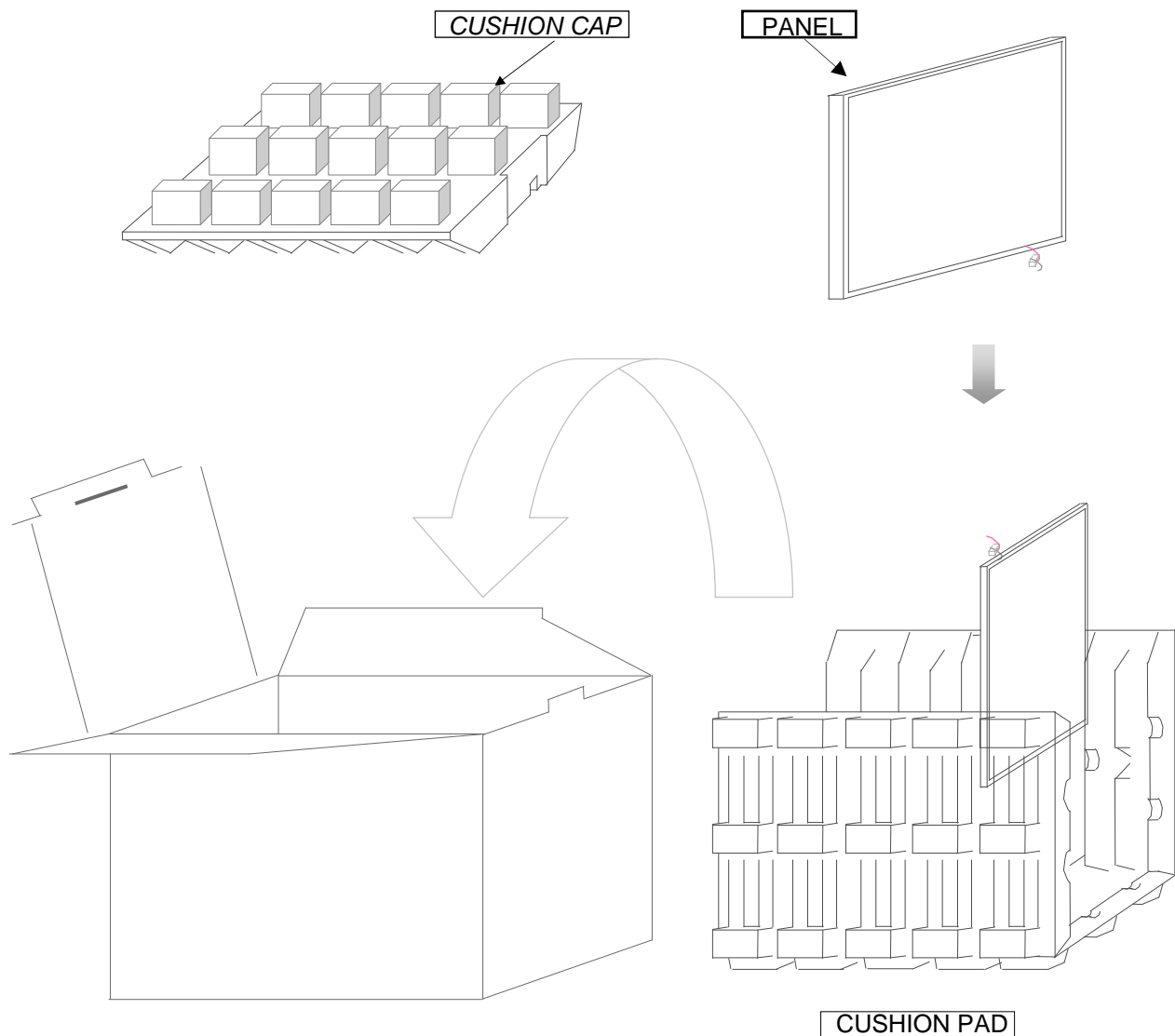

Note 1) Total Weight : Approximately 10 kg

2) Acceptance number of piling : 20 sets

3) Carton size : 344(W) x 432(D) x 329(H)

Samsung Secret

No	Part name	Quantity
1	Static electric protective sack	20
2	Packing case (Inner box) included shock absorber	1 set
3	Pictorial marking	2 pcs
4	Carton	1 set

9. MARKINGS & OTHERS

A nameplate bearing followed by is affixed to a shipped product at the specified location on each product.

(1) Parts number : LTNXXXXXXXX-XXX

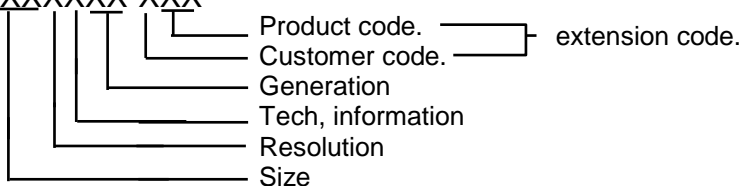

(2) Revision : Three letters

(3) Lot number : X Y 7 A XXX XX X

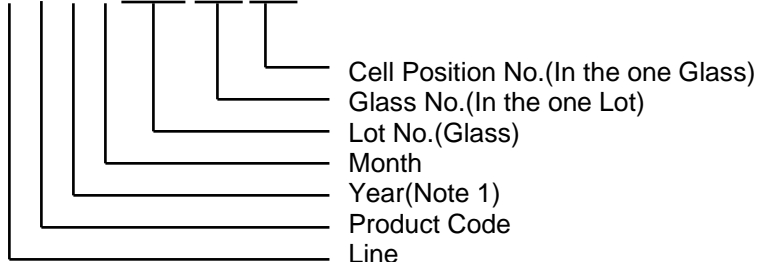

NOTE 1). This code indicating year is omitted in the products of KIHEUNG site.

(5) Nameplate Indication(Following example is only for reference)

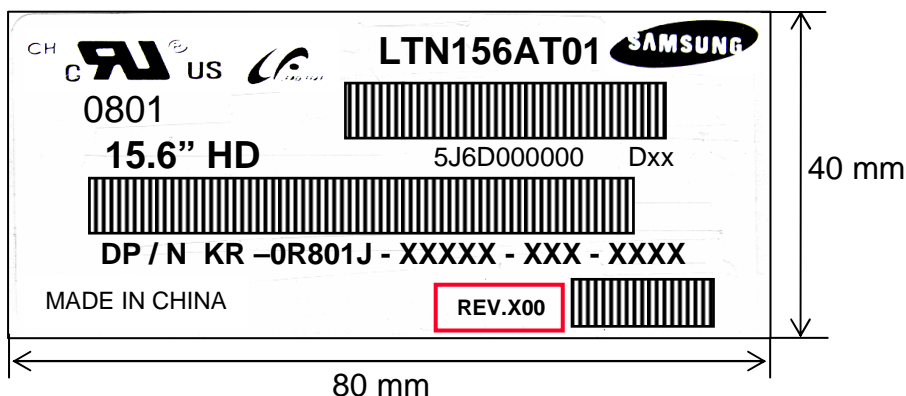

Parts name : LTN156AT01-D
 Lot number : 5J6D000000
 Inspected work week : 0801 Number ("0R801J" is for 156AT01-D)
 DP/N : Part Number for other customer
 REV.X00 : Product Revision Code

Samsung Secret