

SAMSUNG

ELECTRONICS

Product Information



Product Information

SAMSUNG TFT-LCD

MODEL NO. : LTN154X9-L01

LCD Development Team 3

Samsung Electronics Co . , LTD.



SAMSUNG TFT-LCD

Doc.No.	LTN154X9-L01	ISSUED DATE	28/Mar/2007	Page	1 / 13
----------------	--------------	--------------------	-------------	-------------	--------

CONTENTS

General Description	----- (3)
1. Electrical Absolute Ratings	----- (4)
2. Optical Characteristics	----- (5)
3. Electrical Characteristics	----- (6)
3.1 TFT LCD Module	
3.2 Backlight Unit	
4. Block Diagram	----- (7)
4.1 TFT LCD Module	
4.2 Backlight Unit	
5. Input Terminal Pin Assignment	----- (8)
5.1 Input Signal & Power	
5.2 Backlight Unit	
5.3 Timing Diagrams of LVDS For Transmitting	
6. Interface Timing	----- (10)
6.1 Timing Parameters	
6.2 Timing Diagrams of interface Signal	
6.3 Power ON/OFF Sequence	
7. Outline Dimension	----- (12)

GENERAL DESCRIPTION

DESCRIPTION

LTN154X9 is a color active matrix TFT (Thin Film Transistor) liquid crystal display (LCD) that uses amorphous silicon TFT as a switching devices. This model is composed of a TFT LCD panel, a driver circuit, and back-light system. The resolution of a 15.4 " contains 1280 x 800 pixels and can display up to 262,144colors. 6 o'clock direction is the optimum viewing angle.

FEATURES

- Ultra High Luminance with 2-CCFL
- High Color Gamut (Typical 72%)
- Wide viewing angle (H130/ V 100)
- High contrast ratio (Ultra fine & shine view)
- WXGA (1280x800 pixels) resolution
- Low power consumption
- DE (Data enable) only mode.
- 3.3V LVDS (FPD Link) Interface with 1 pixel / clock
- On board EDID chip
- RoHS Compliance

APPLICATIONS

- Multimedia Notebook PC
- Display terminals for AV application products
- If the usage of this product is not for PC application, but for others, please contact SEC.

GENERAL INFORMATION

Item	Specification	Unit	Note
Display area	331.2(H) X 207.0(V) (15.4"diagonal)	mm	
Driver element	a-si TFT active matrix		
Display colors	262,144		
Number of pixel	1280 x RGB x 800	pixel	16 : 10
Pixel arrangement	RGB vertical stripe		
Pixel pitch	0.25875(H) x 0.25875(V)	mm	
Display Mode	Normally white		
Surface treatment	Haze 0(Glare), Hardness 3H		

Mechanical Information

ITEM		MIN	TYP	MAX	NOTE
Module size (mm)	Horizontal (H)	343.5	344.0	344.5	
	Vertical (V)	225.5	226.0	226.5	
	Thickness (T)	-	6.7	7.0	(1)
Weight (g)		-	680	700	

Note (1) Measurement condition of outline dimension
 . Equipment : Vernier Calipers
 . Push Force : 500g · f (minimum)

1. ELECTRICAL ABSOLUTE RATINGS**(1) TFT LCD MODULE**

$$V_{DD} = 3.3V, V_{SS} = GND = 0V$$

Item	Symbol	Min.	Max.	Unit	Note
Power Supply Voltage	V_{DD}	$V_{DD} - 0.3$	$V_{DD} + 0.3$	V	(1)
Logic Input Voltage	V_{DD}	$V_{DD} - 0.3$	$V_{DD} + 0.3$	V	(1)

Note (1) Within T_a (25 ± 2 °C)

(2) BACK-LIGHT UNIT

$$T_a = 25 \pm 2$$
 °C

Item	Symbol	Min.	Max.	Unit	Note
Lamp Current	I_L	3.0	7.0	mArms	(1)
Lamp frequency	F_L	45	80	kHz	(1)

Note 1) Permanent damage to the device may occur if maximum values are exceeded
 Functional operation should be restricted to the conditions described under normal operating conditions.

2. OPTICAL CHARACTERISTICS

The following items are measured under stable conditions. The optical characteristics should be measured in a dark room or equivalent state.

Measuring equipment : TOPCON BM-5A and PR-650

* Ta = 25 ± 2 °C, VDD=3.3V, fv= 60Hz, fdCLK = 68.9MHz, IL = 6.0 mA

Item	Symbol	Condition	Min.	Typ.	Max	Unit	
Contrast Ratio (5 Points)	CR	Normal Viewing Angle $\phi = 0$ $\theta = 0$	450	600	-	-	
Response Time at Ta (Rising + Falling)	T _{RT}		-	25	35	msec	
Average Luminance of White (5 Points)	Y _{L,AVE}		435	500	-	cd/m ²	
Color Chromaticity (CIE)	Red		R _X	0.614	0.644	0.674	-
			R _Y	0.305	0.335	0.365	
	Green		G _X	0.258	0.288	0.318	
			G _Y	0.568	0.598	0.628	
	Blue		B _X	0.114	0.144	0.174	
			B _Y	0.043	0.073	0.103	
	White		W _X	0.283	0.313	0.343	
		W _Y	0.299	0.329	0.359		
Viewing Angle	Hor.	θ_L	60	65	-	Degrees	
		θ_H	60	65	-		
	Ver.	ϕ_H	45	50	-		
		ϕ_L	45	50	-		
13 Points White Variation	δ_L			2.2	-		

3. ELECTRICAL CHARACTERISTICS

3.1 TFT LCD MODULE

Ta= 25 ± 2°C

Item	Symbol	Min.	Typ.	Max.	Unit	Note	
Voltage of Power Supply	V _{DD}	3.0	3.3	3.6	V		
Differential Input Voltage for LVDS Receiver Threshold	High	V _{IH}	-	-	+100	mV	V _{CM} = +1.2V
	Low	V _{IL}	-100	-	-	mV	
Vsync Frequency	f _v	-	60	-	Hz		
Hsync Frequency	f _H	-	48.96	-	KHz		
Main Frequency	f _{DCLK}	63.84	68.94	74.97	MHz		
Rush Current	I _{RUSH}	-	-	1.5	A	(4)	
Current of Power Supply	White	I _{DD}	-	300	-	mA	(2),(3)*a
	Mosaic		-	310	-	mA	(2),(3)*b
	Max. pt.		-	400	480	mA	(2),(3)*c

3.2 BACK-LIGHT UNIT

The backlight system is an edge-lighting type with a single CCFT (Cold Cathode Fluorescent Tube).
The characteristics of a single lamp are shown in the following table.

INVERTER : SIC-1801

Ta= 25 ± 2 °C

Item	Symbol	Min.	Typ.	Max.	Unit	Note
Lamp Current	I _L	2.0 /Duty 20%	6.0	6.5	mArms	
Lamp Voltage	V _L	-	700/CCFL	-	Vrms	I _L =6.0mA
Frequency	f _L	45	60	70	KHz	
Power Consumption	P _L		4.2/CCFL		W	I _L =6.0mA
Operating Life Time	Hr	12,000			Hour	
Startup Voltage	V _s	-	-	1180	Vrms	25°C
				1300	Vrms	0°C
Lamp startup time		-	-	1.0	sec	

4. BLOCK DIAGRAM

4.1 TFT LCD Module

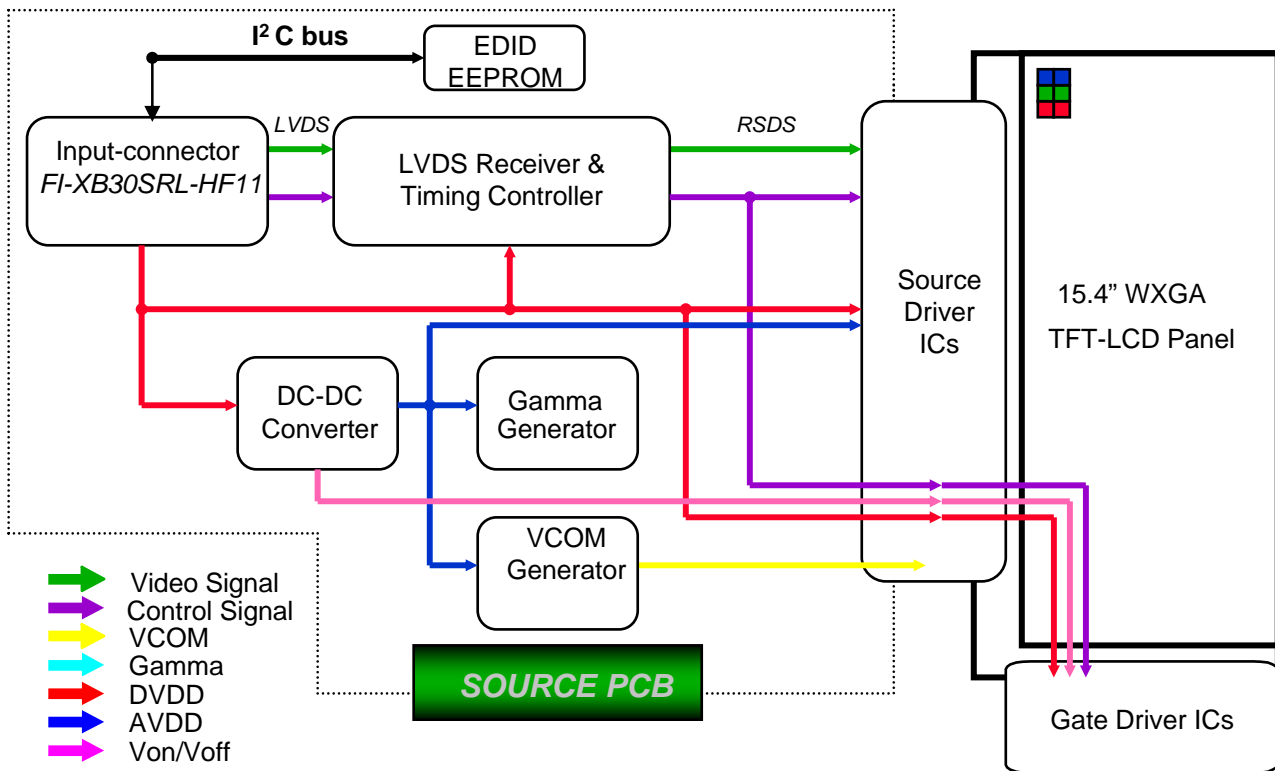

4.2 BACK-LIGHT UNIT (2lamp, Y-stack structure)

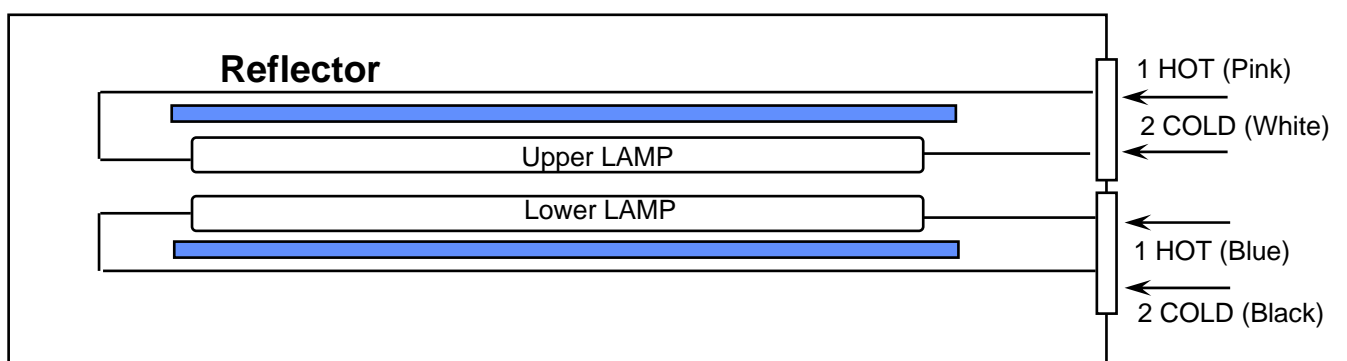

Note1) The output of the inverter may change according to the material of the reflector.

5. INPUT TERMINAL PIN ASSIGNMENT

5.1. Input Signal & Power LVDS, Connector : JAE, FI-XB30SRL-HF11
Mating Connector: JAE, FI-X30M

No.	Symbol	Function	Polarity	Remarks
1	VSS	Ground		
2	VDD	POWER SUPPLY +3.3V		
3	VDD	POWER SUPPLY +3.3V		
4	VEEDID	DDC 3.3V Power		
5	BIST	Panel BIST enable		
6	CLKEDID	DDC Clock		
7	DATAEDID	DDC data		
8	RxIN0-	LVDS Differential Data INPUT (R0-R5,G0)	Negative	
9	RxIN0+	LVDS Differential Data INPUT (R0-R5,G0)	Positive	
10	GND	Ground		
11	RxIN1-	LVDS Differential Data INPUT (G1-G5,B0-B1)	Negative	
12	RxIN1+	LVDS Differential Data INPUT (G1-G5,B0-B1)	Positive	
13	GND	Ground		
14	RxIN2-	LVDS Differential Data INPUT (B2-B5,Sync,DE)	Negative	
15	RxIN2+	LVDS Differential Data INPUT (B2-B5,Sync,DE)	Positive	
16	Vss	Ground		
17	ClkIN-	LVDS Differential Clock INPUT	Negative	
18	ClkIN+	LVDS Differential Clock INPUT	Positive	
19	Vss	Ground		
20	NC	No connect		
21	NC	No connect		
22	NC	No connect		
23	NC	No connect		
24	NC	No connect		
25	NC	No connect		
26	NC	No connect		
27	NC	No connect		
28	NC	No connect		
29	NC	No connect		
30	NC	No connect		

5.2 BACK LIGHT UNIT

Connector : JST BHSR - 02VS -1 * 2pcs

Pin No.	Symbol	Color	Function
1	HOT	Blue / Pink	High Voltage
2	COLD	Black/ White	Low Voltage

5.3 Timing Diagrams of LVDS For Transmission

LVDS Receiver : Integrated T-CON

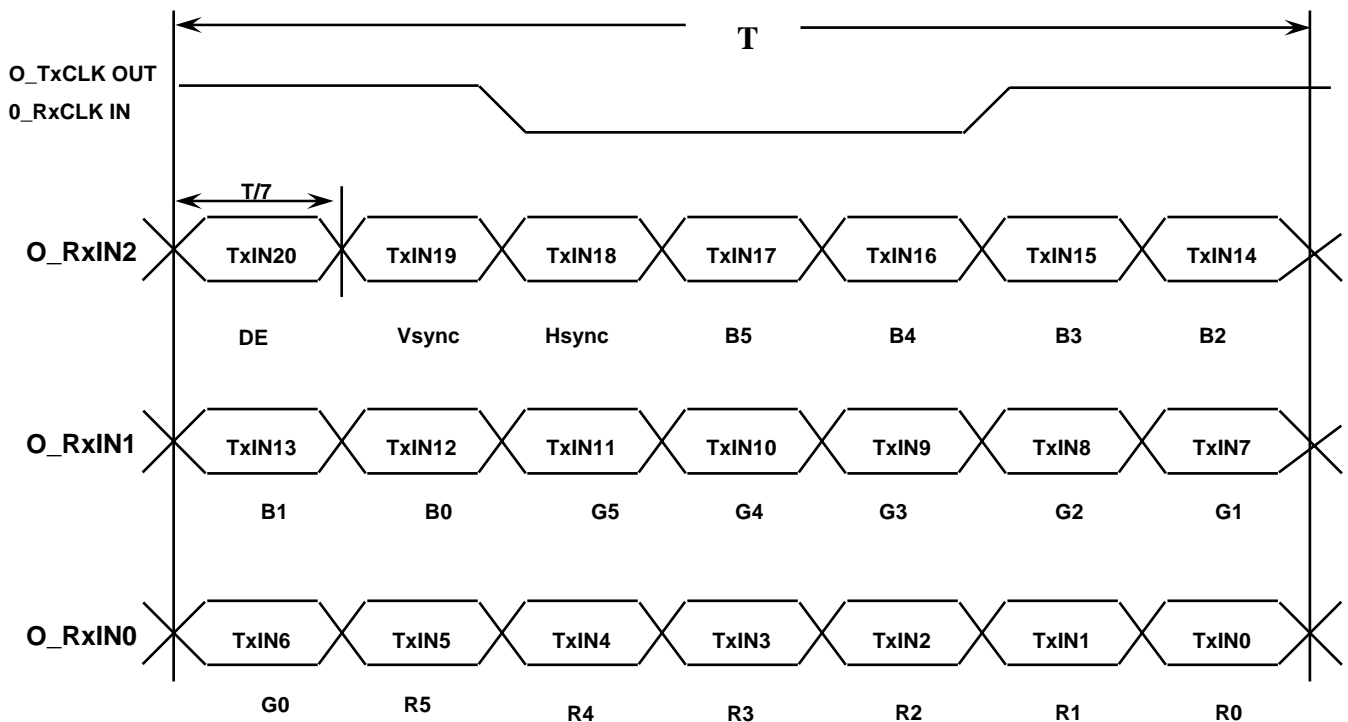

6. INTERFACE TIMING

6.1 Timing Parameters

Signal	Item	Symbol	Min.	Typ.	Max.	Unit	Note
Frame Frequency	Cycle	TV	806	816	833	Lines	-
Vertical Active Display Term	Display Period	TVD	-	800	-	Lines	-
One Line Scanning Time	Cycle	TH	1320	1408	1500	Clocks	-
Horizontal Active Display Term	Display Period	THD	-	1280	-	Clocks	-

6.2 Timing diagrams of interface signal

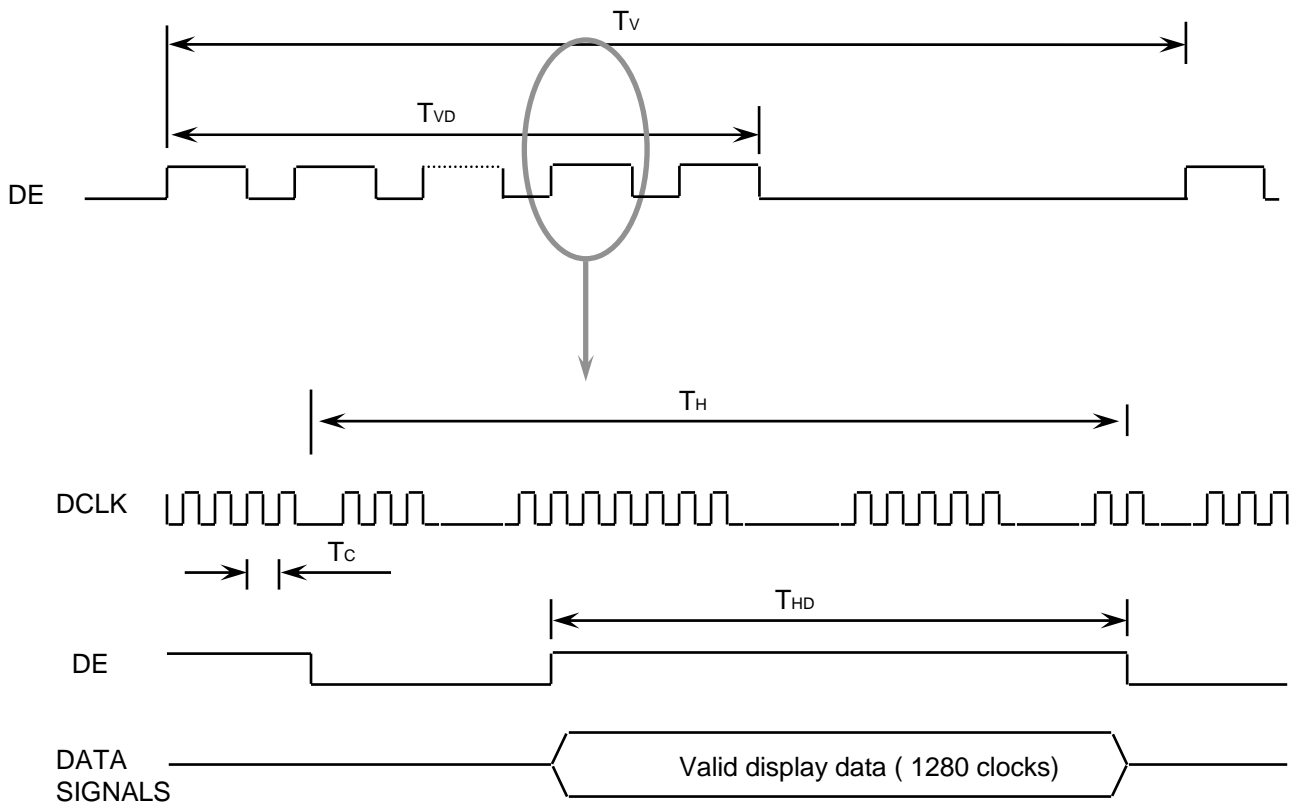

6.3 Power ON/OFF Sequence

: To prevent a latch-up or DC operation of the LCD module, the power on/off sequence should be as the diagram below. (VESA recommendation)

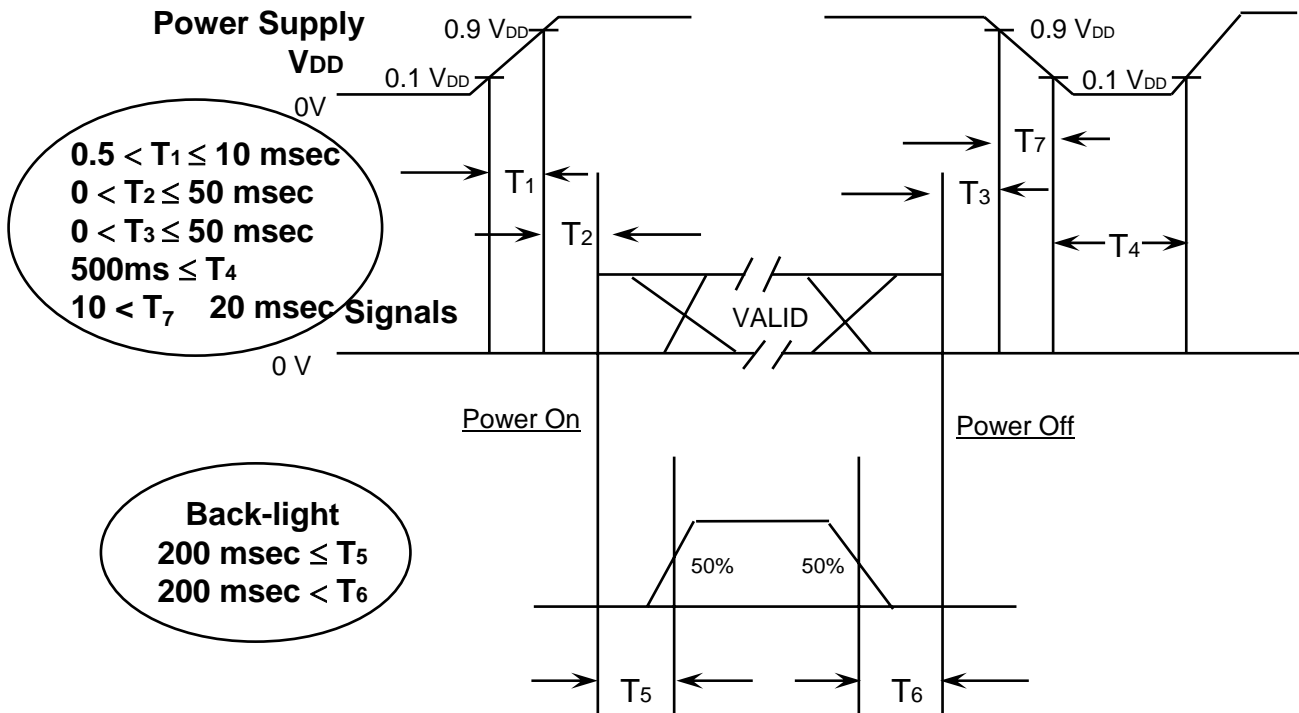

Power ON/OFF Sequence

- T1 : Vdd rising time from 10% to 90%
- T2 : The time from Vdd to valid data at power ON.
- T3 : The time from valid data off to Vdd off at power Off.
- T4 : Vdd off time for Windows restart
- T5 : The time from valid data to B/L enable at power ON.
- T6 : The time from valid data off to B/L disable at power Off.
- T7 : Vdd falling time from 90% to 10%

NOTE.

- (1) The supply voltage of the external system for the module input should be the same as the definition of V_{DD}.
- (2) Apply the lamp voltage within the LCD operation range. When the back-light turns on before the LCD operation or the LCD turns off before the back-light turns off, the display may momentarily become white.
- (3) In case of V_{DD} = off level, please keep the level of input signals on the low or keep a high impedance.
- (4) T₄ should be measured after the module has been fully discharged between power off and on period.
- (5) Interface signal shall not be kept at high impedance when the power is on.
- (6) To prevent the garbage display, SEC basically recommends VESA standard.

7. MECHANICAL OUTLINE DIMENSION

[Refer to the next page]

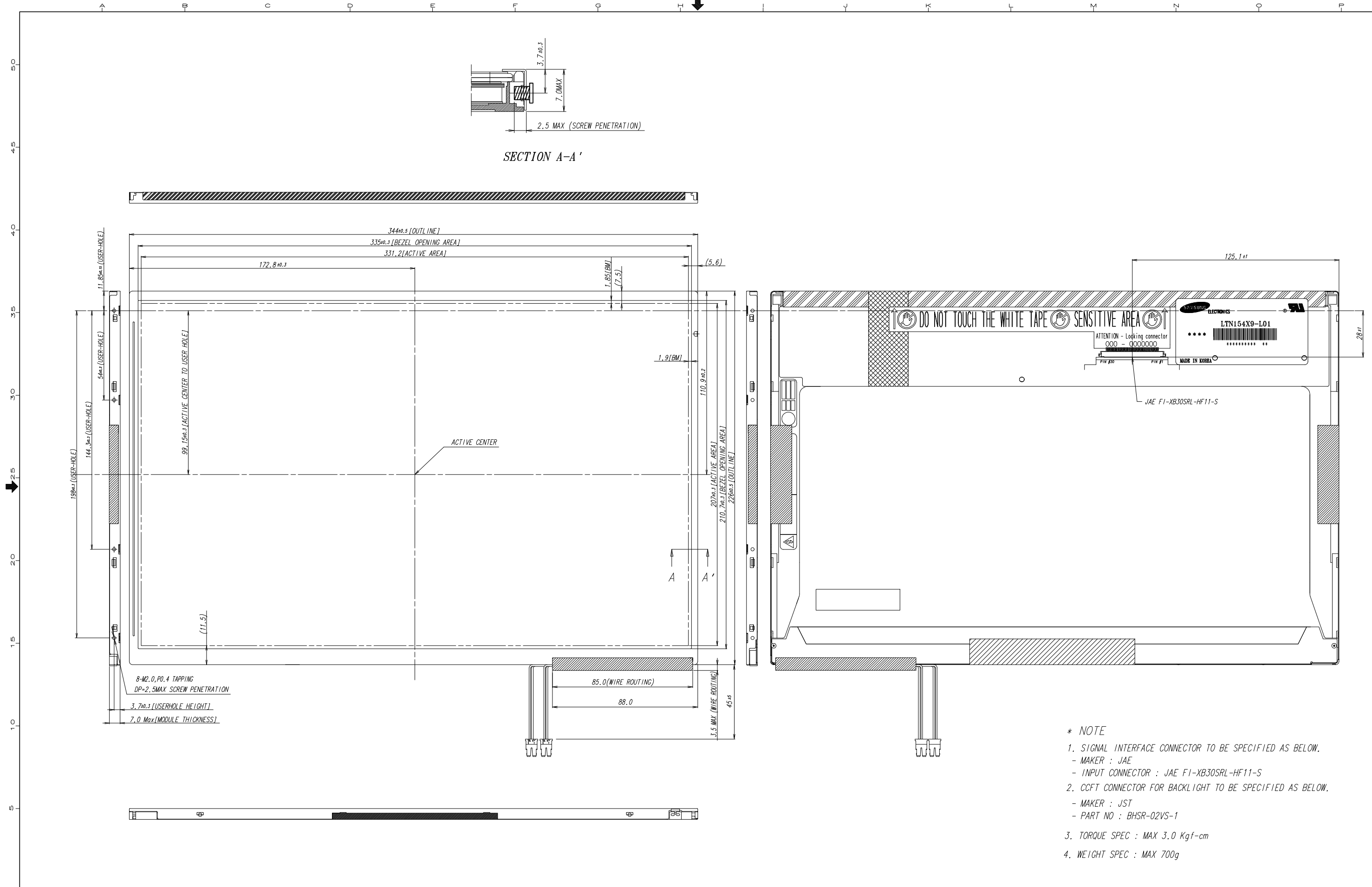

SECTION A-A'

- * NOTE
- SIGNAL INTERFACE CONNECTOR TO BE SPECIFIED AS BELOW.
 - MAKER : JAE
 - INPUT CONNECTOR : JAE FI-XB30SRL-HF11-S
 - CCFT CONNECTOR FOR BACKLIGHT TO BE SPECIFIED AS BELOW.
 - MAKER : JST
 - PART NO : BHSR-02VS-1
 - TORQUE SPEC : MAX 3.0 Kgf-cm
 - WEIGHT SPEC : MAX 700g

STEP	GENERAL TOLERANCE			REV	DATE	DESCRIPTION OF REVISION				REASON		CHG'D BY	
	LEVEL 1	LEVEL 2	LEVEL 3			UNIT	mm	DRA'N BY	DES'D BY	CHK'D BY	APP'D BY		MODEL NAME
0 < X ≤ 4	±0.05	±0.1	±0.2	SCALE	1/1	Y.K.KIM	M.S.Kim	D.C.YANG	2005.03.09	2005.03.09	2005.03.09	LTN154X9-L01	1/1
4 < X ≤ 16	±0.08	±0.15	±0.3	TOLERANCE	LEVEL3							OUTLINE DIMENSION	
16 < X ≤ 64	±0.12	±0.25	±0.5										
64 < X ≤ 256	±0.25	±0.4	±0.8										
SAMSUNG ELECTRONICS										CODE NO.		VER 000	