

**SAMSUNG**

**ELECTRONICS**

Approval



TO :

DATE : Sep 05. 2005

**SAMSUNG TFT-LCD**

**MODEL NO.: LTN154X3-L04**

**NOTE** : Extension code [ -0 ]  
→ LTN154X3-L04-0  
Surface type [ **ARC150T** ]  
Green product (Complied with RoHS requirement)

Any Modification of Spec is not allowed without SEC' permission

APPROVED BY :

*K. H. Shin*

PREPARED BY : **Application Engineering Group**

**SAMSUNG ELECTRONICS CO., LTD.**



Doc.No.

LTN154X3-L04

Rev.No

04-A01-S-050905

Page

1 / 28

## CONTENTS

Revision History	----- ( 3 )
General Description	----- ( 4 )
1. Absolute Maximum Ratings	----- ( 5 )
1.1 Absolute Ratings of environment	
1.2 Electrical Absolute Ratings	
2. Optical Characteristics	----- ( 7 )
3. Electrical Characteristics	----- ( 11 )
3.1 TFT LCD Module	
3.2 Backlight Unit	
4. Block Diagram	----- ( 14 )
4.1 TFT LCD Module	
4.2 Backlight Unit	
5. Input Terminal Pin Assignment	----- ( 15 )
5.1 Input Signal & Power	
5.2 LVDS Interface	
5.3 Backlight Unit	
5.4 Timing Diagrams of LVDS For Transmitting	
5.5 Input Signals, Basic Display Colors and Gray Scale of Each Color.	
5.6 Pixel format	
6. Interface Timing	----- ( 20 )
6.1 Timing Parameters(DE Mode)	
6.2 Timing Diagrams of interface Signal (DE Mode)	
6.3 Power ON/OFF Sequence	
7. Outline Dimension	----- ( 22 )
8. Product Markings and Others	----- ( 23 )
9.General Precautions	----- ( 24 )
10. EDID	----- ( 26 )

**REVISION HISTORY**

Approval

Date	Revision No.	Page	Summary
Mar.02, 2005	P00	All	LTN154X3-L04 model rev.000 specification was First issued.  ● SEC's P/N LTN154X3-L04-00R4  ● Lenovo's product code Lenovo P/N : 13N7015 FRU P/N : 13N7016 EC NO : - Header Code : 1ZABW
July 04. 2005	P01	7 11 15 21	Updated the Uniformity Updated the operating frequency and current Input connector was changed to FI-XB30SRL-HF11-S. Modified the power sequence
July 21. 2005	A00	All 7 23	LTN154X3-L04-000 model was approved Added the typical value of CR is 500 The Lenovo's Label was changed P/N : 13N7015 FRU : 13N7016 EC NO : - Header Code : 1ZABW
Sep 05, 2005	A01	22 23	The outline drawing was changed . Cushion was added on the PCB cover and under the connector. The Lenovo's Header Code was changed As-is : 1ZABW → To-be : 1ZB4N

**Doc.No.**

LTN154X3-L04

**Rev.No**

04-A01-S-050905

**Page**

3 / 28

## GENERAL DESCRIPTION

### DESCRIPTION

LTN154X3-L04 is a color active matrix TFT (Thin Film Transistor) liquid crystal display (LCD) that uses amorphous silicon TFT as a switching devices. This model is composed of a TFT LCD panel, a driver circuit and a backlight system. The resolution of a 15.4" contains 1,280 x 800 pixels and can display up to 262,144 colors. 6 O'clock direction is the Optimum viewing angle.

### FEATURES

- Thin and light weight
- High contrast ratio, high aperture structure
- Wide XGA (1280x800 pixels) resolution
- Fast Response Time
- Low power consumption
- Single CCFL
- DE (Data enable) only mode.
- 3.3V LVDS Interface
- On board EDID chip
- Auto Recovery Function
- RoHS Compliance

### APPLICATIONS

- Notebook PC and desktop monitors
- If the usage of this product is not for PC application, but for others, please contact SEC

## GENERAL INFORMATION

Item	Specification	Unit	Note
Display area	331.2(H) X 207.0(V) (15.4"diagonal)	mm	
Driver element	a-si TFT active matrix		
Display colors	262,144		
Number of pixel	1280 x 800 ( 16 : 10, Wide XGA )	pixel	
Pixel arrangement	RGB vertical stripe		
Pixel pitch	0.25875(H) x 0.25875(V)	mm	
Display Mode	Normally white		
Surface treatment	HAZE 42, HARD-COATING 2H, ARC150T		

## Mechanical Information

Item		Min.	Typ.	Max.	Unit	Note
Module size	Horizontal (H)	343.5	344.0	344.5	mm	
	Vertical (V)	221.5	222.0	222.5	mm	
	Depth (D)	-	6.2	6.5	mm	
Weight		-	530	545	g	

## 1. ABSOLUTE MAXIMUM RATINGS

### 1.1 ENVIRONMENTAL ABSOLUTE RATINGS

ITEM	SYMBOL	MIN.	MAX.	UNIT	NOTE
Storage temperate	$T_{STG}$	-25	60	$^{\circ}C$	(1)
Operating temperate (Temperature of glass surface)	$T_{OPR}$	0	50	$^{\circ}C$	(1)
Shock ( non-operating )	Snop	-	210	G	(2), (4)
Vibration (non-operating)	Vnop	-	1.5	G	(3), (4)

Note (1) Temperature and relative humidity range are shown in the figure below.

95 % RH Max. (  $40^{\circ}C \geq T_a$  )

Maximum wet - bulb temperature at  $39^{\circ}C$  or less. ( $T_a > 40^{\circ}C$ ) No condensation.

(2) 3ms, half sine wave, one time for  $\pm X, \pm Y, \pm Z$ .

(3) 10 ~ 300 ~ 10 Hz, Sweep rate 10 min, 30 min for X,Y,Z.

(4) At testing Vibration and Shock, the fixture in holding the Module to be tested have to be hard and rigid enough so that the Module would not be twisted or bent by the fixture.

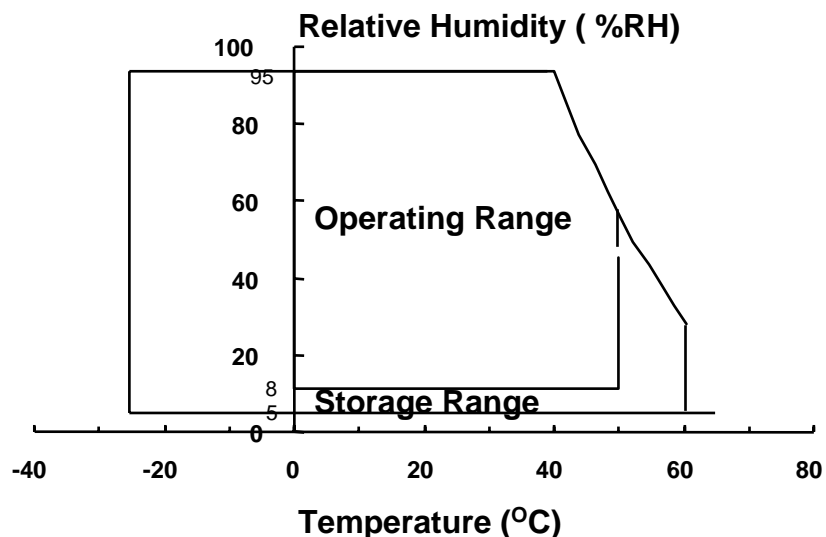

## 1.2 ELECTRICAL ABSOLUTE RATINGS

## (1) TFT LCD MODULE

( V<sub>SS</sub> = GND = 0 V )

ITEM	SYMBOL	MIN.	MAX.	UNIT	NOTE
Power Supply Voltage	V <sub>CC</sub>	V <sub>SS</sub> -0.3	(V <sub>CC</sub> + 0.3)	V	(1)
Logic Input Voltage	V <sub>IN</sub>	V <sub>SS</sub> -0.3	(V <sub>CC</sub> + 0.3)	V	(1)

NOTE (1) Within Ta ( 25 ± 2 °C )

## (2) BACK-LIGHT UNIT

Ta = 25 ± 2 °C

ITEM	SYMBOL	MIN.	MAX.	UNIT.	NOTE
Lamp current	I <sub>L</sub>	2.0	7.0	mA <sub>RMS</sub>	(1)
Lamp frequency	F <sub>L</sub>	50	80	KHz	(1)

NOTE (1) Permanent damage to the device may occur if maximum values are exceeded.  
Functional operation should be restricted to the conditions described under Normal Operating Conditions.

## 2. OPTICAL CHARACTERISTICS

The following items are measured under stable conditions. The optical characteristics should be measured in a dark room or equivalent state with the methods shown in Note (5).

Measuring equipment : TOPCON BM-5A

\*  $T_a = 25 \pm 2^\circ\text{C}$  ,  $V_{cc} = 3.3\text{V}$ ,  $f_v = 60\text{Hz}$ ,  $f_{dCLK} = 65\text{MHz}$ ,  $I_L = 6.0\text{mA}$

Item	Symbol	Condition	Min.	Typ.	Max	Unit	Note	
Contrast Ratio (5 Points)	CR	Normal Viewing Angle $\phi = 0$ $\theta = 0$	300	500	-	-	(1), (2), (5)	
Response Time at 25 °C	Rising		$T_{R+T_f}$	-	25	35	msec	(1), (3)
	Falling							
Average Luminance of White (center)	$Y_{L,AVE}$			170	200	-	cd/m <sup>2</sup>	$I_L = 6.0\text{mA}$ (1), (4)
Color Chromaticity ( CIE )	Red		$R_x$	0.562	0.590	0.618	-	(1), (5) PR-650
			$R_y$	0.320	0.340	0.360		
	Green		$G_x$	0.292	0.320	0.348		
			$G_y$	0.530	0.550	0.570		
	Blue		$B_x$	0.124	0.152	0.180		
			$B_y$	0.110	0.130	0.150		
	White	$W_x$	0.285	0.313	0.341			
		$W_y$	0.309	0.329	0.349			
Viewing Angle	Hor.	$\theta_L$	-	65	-	Degree s	(1), (5) BM-5A	
		$\theta_H$	-	65	-			
	Ver.	$\phi_H$	-	50	-			
		$\phi_L$	-	50	-			
13 Points White Variation	$\delta_L$		50%	-	-	-	(6)	
5 Points White Variation	$\delta_L$		80%	-	-	-	(6)	

Note 1) Definition of Viewing Angle : Viewing angle range ( $10 \leq C/Rat$  center point )

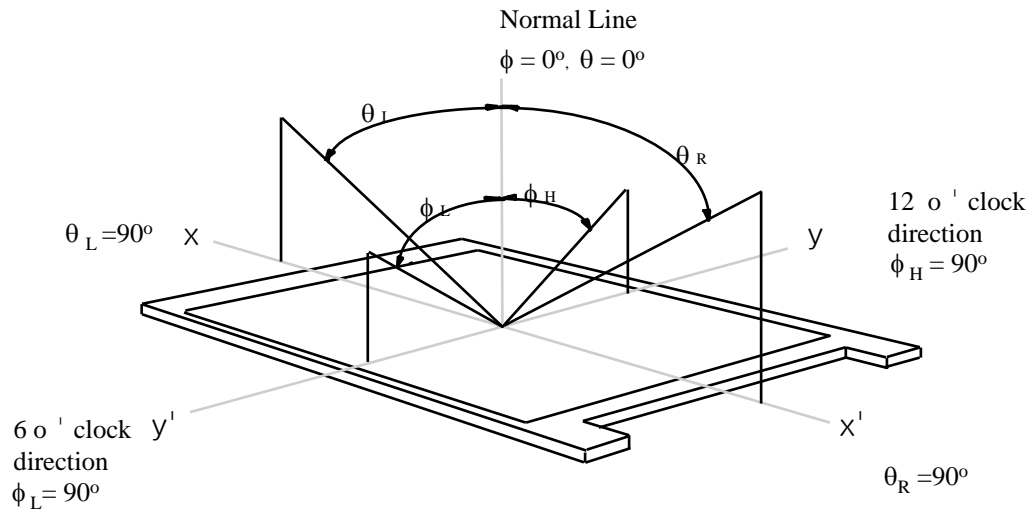

Note 2) Definition of Contrast Ratio (CR) : Ratio of gray max (Gmax) ,gray min (Gmin) at 5 points(1, 3, 5, 7, 9)

$$CR = \frac{CR(1) + CR(3) + CR(5) + CR(7) + CR(9)}{5}$$

POINTS: (1), (3), (5), (7), (9) at FIGURE OF NOTE 6)

Note 3) Definition of Response time : Sum of  $T_R, T_F$

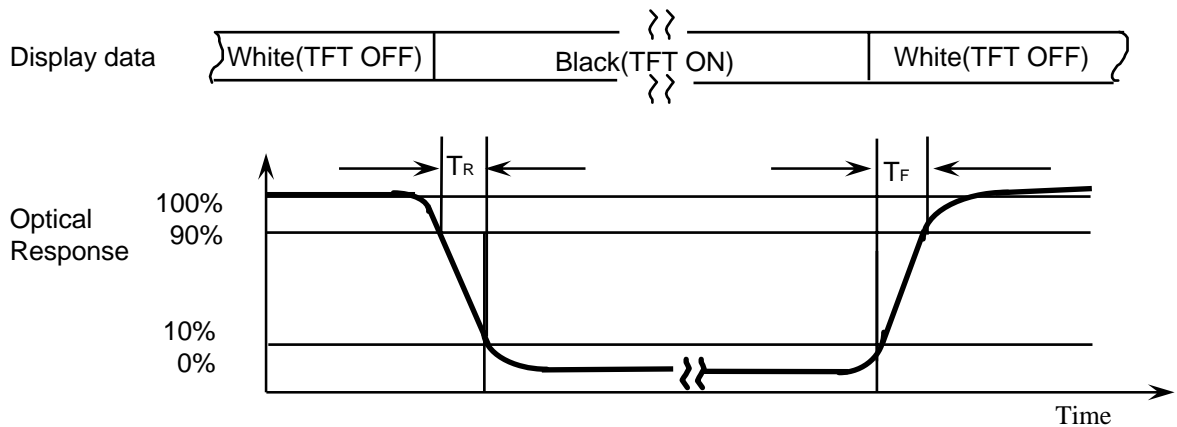



Note 4) Definition of Luminance of White : measure the luminance of white at center points.

Luminance of White ( $Y_L$ )  
 Measuring Lamp Current is 6.0mA

$$Y_L = Y_{L5}$$

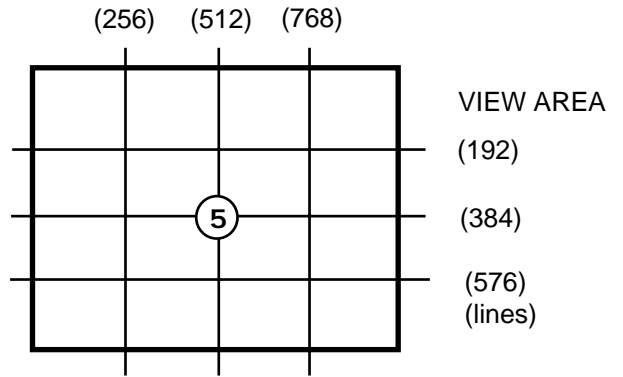

Note 5) After stabilizing and leaving the panel alone at a given temperature for 30 min , the measurement should be executed. Measurement should be executed in a stable, windless, and dark room. 30 min after lighting the back-light. This should be measured in the center of screen.  
 Lamp current : 6.0mA  
 Environment condition :  $T_a = 25^{\circ}\text{C} \pm 2^{\circ}\text{C}$

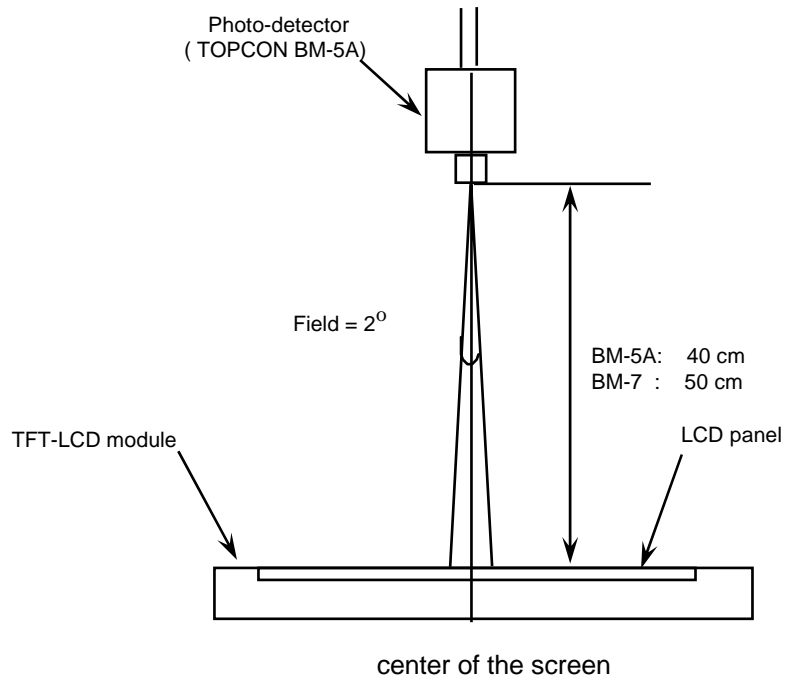

Optical characteristics measurement setup

Note 6) Definition of 13 points white variation, CR variation(  $C_{VER}$  ) [ ① ~ ⑬ ]

$$\text{13 points white variation (\%)} = \frac{\text{Minimum luminance of 13 points}}{\text{Maximum luminance of 13 points}} \times 100$$

Meet ISO13406-2 Luminance uniformity

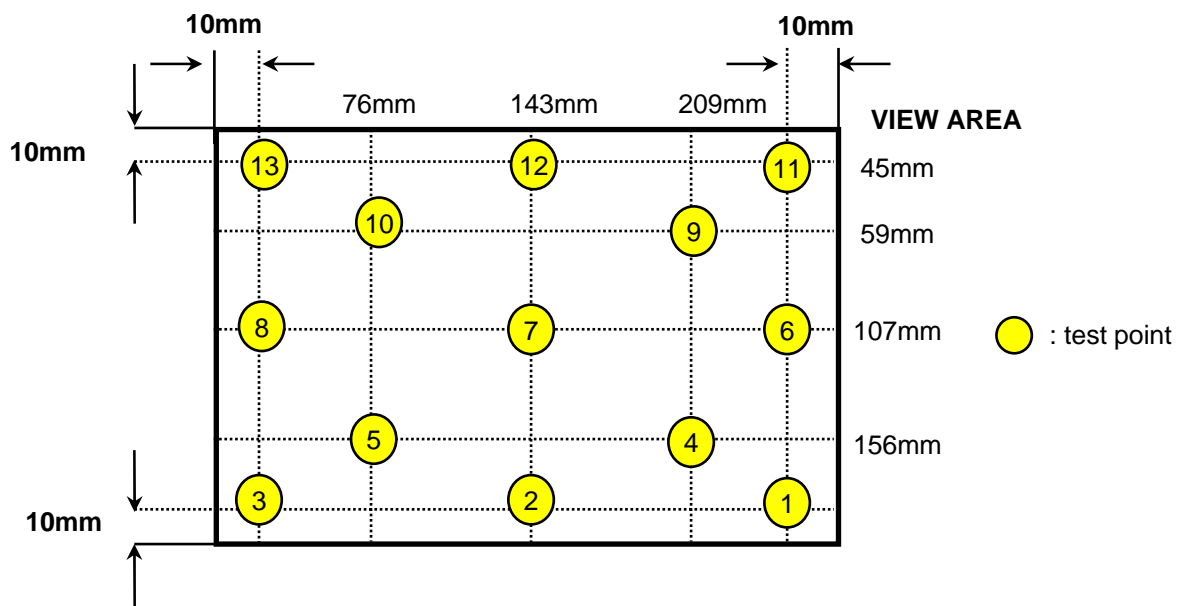

Note 7) Definition of 5 points white variation, CR variation(  $C_{VER}$  ) [ 4,5,7,9,10 ]

$$\text{5 points white variation (\%)} = \frac{\text{Minimum luminance of 5 points}}{\text{Maximum luminance of 5 points}} \times 100$$

### 3. ELECTRICAL CHARACTERISTICS

Approval

#### 3.1 TFT LCD MODULE

Ta=25 ± 2 °C

ITEM		SYMBOL	MIN	TYP	MAX	UNIT	NOTE
Voltage of Power Supply		V <sub>DD</sub>	3.0	3.3	3.6	V	
Differential Input Voltage for LVDS Receiver Threshold	High	V <sub>IH</sub>	-	-	+100	mV	V <sub>CM</sub> =+1.2V
	Low	V <sub>IL</sub>	-100	-	-	mV	
Vsync Frequency	60Hz	Hsync Freq	F <sub>H</sub>	46.38	49.38	60	KHz
		Main Freq	F <sub>DCLK</sub>	60.99	71.11	105	MHz
	50Hz	Hsync Freq	F <sub>H</sub>	38.65	41.15	50	KHz
		Main Freq	F <sub>DCLK</sub>	50.82	59.26	87.5	MHz
	40Hz	Hsync Freq	F <sub>H</sub>	30.92	32.92	40	KHz
		Main Freq	F <sub>DCLK</sub>	40.66	47.4	70	MHz
Rush Current		I <sub>RUSH</sub>	-	-	1.5	A	(4)
Current of Power Supply	White	I <sub>DD</sub>	-	310	-	mA	(2),(3)*a
	Mosaic		-	330	-	mA	(2),(3)*b
	WinXP Pattern		-	340	-	mA	(2),(3)*c
	Max Pattern		-	380	500	mA	(2),(3)*d

Note (1) Display data pins and timing signal pins should be connected.(GND=0V)

(2) f<sub>V</sub>=60Hz, f<sub>DCLK</sub> =71.11MHZ, V<sub>dd</sub> = 3.3V , DC Current.

(3) Power dissipation pattern

\*a) White Pattern

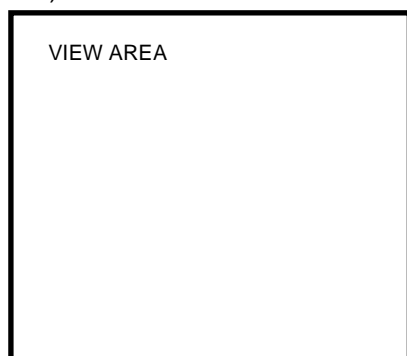

\*b) Mosaic Pattern

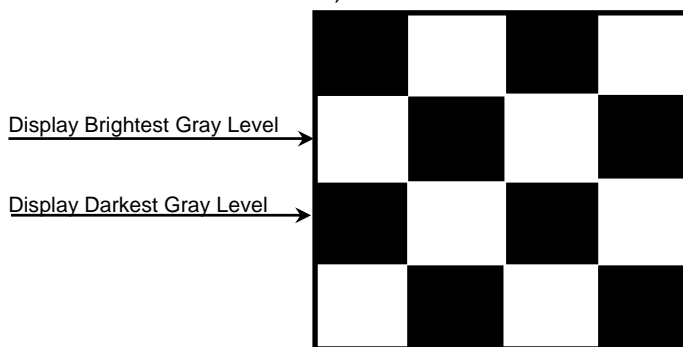

\*c) WinXP Pattern

Approval



\*d) 1dot Inversion Pattern

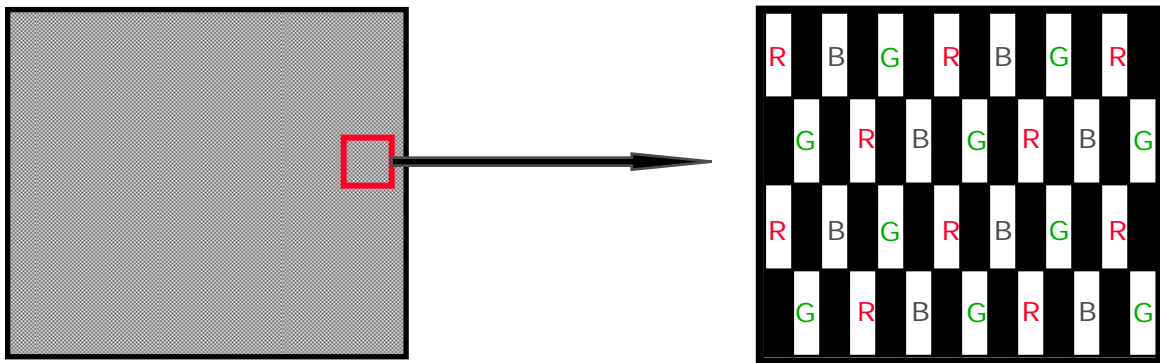

4) Rush current measurement condition

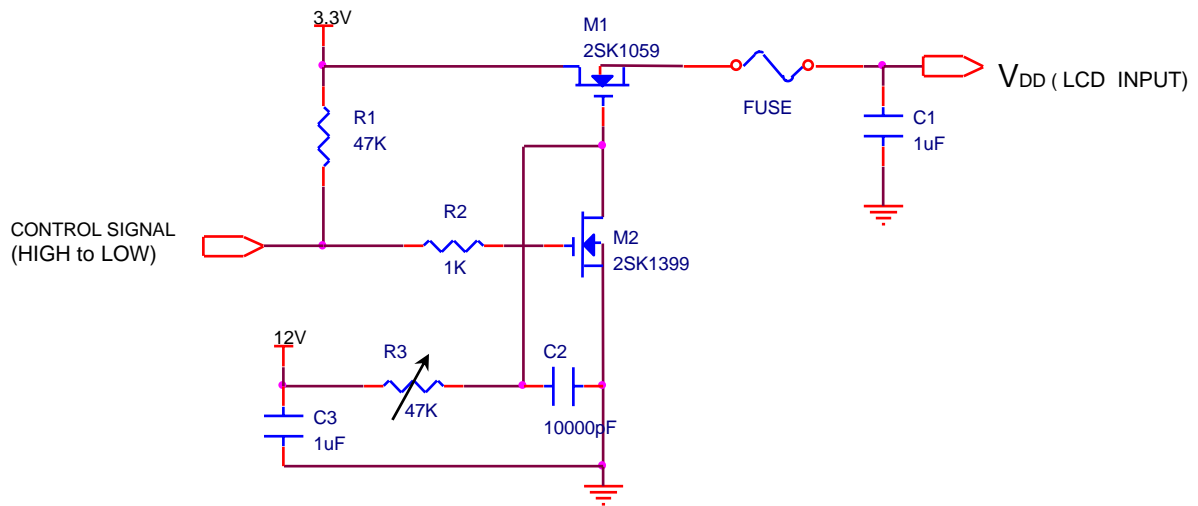

V<sub>DD</sub> rising time is 470us

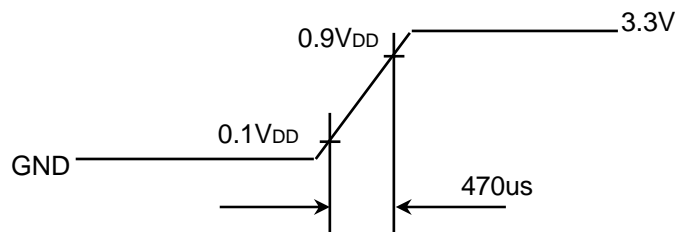

### 3.2 BACK-LIGHT UNIT

The backlight system is an edge - lighting type with a single CCFT ( Cold Cathode Fluorescent Tube ).  
The characteristics of a single lamp are shown in the following tables.

INVERTER : SEM, SIC130T

Ta=25 ± 2 °C

Item	Symbol	Min.	Typ.	Max.	Unit	Note
Lamp Current	I <sub>L</sub>	3.0 (duty 15%)	6.0	6.5	mArms	(1), (6)
Lamp Voltage	V <sub>L</sub>	-	720	-	Vrms	I <sub>L</sub> =6.0mA
Frequency	f <sub>L</sub>	50	60	65	KHz	(2)
Power Consumption	P <sub>L</sub>		4.3		W	(3) I <sub>L</sub> =6.0mA
Operating Life Time	Hr	10,000			Hour	(4)
Startup Voltage	V <sub>s</sub>	-	-	1200	Vrms	25°C, (5)
				1370	Vrms	0°C, (5)
Lamp startup time		-	-	1.0	sec	(5)

**Note)** The waveform of the inverter output voltage must be area symmetric and the design of the inverter must have specifications for the modularized lamp.

The performance of the backlight, for example life time or brightness, is much influenced by the characteristics of the DC-AC inverter for the lamp. So all the parameters of an inverter should be carefully designed so as not to produce too much leakage current from high-voltage output of the inverter. When you design or order the inverter, please make sure that a poor lighting caused by the mismatch of the backlight and the inverter(miss lighting, flicker, etc.) never occur. When you confirm it, the module should be operated in the same condition as it is installed in your instrument.

Note (1) Lamp current is measured with a high frequency current meter as shown below.

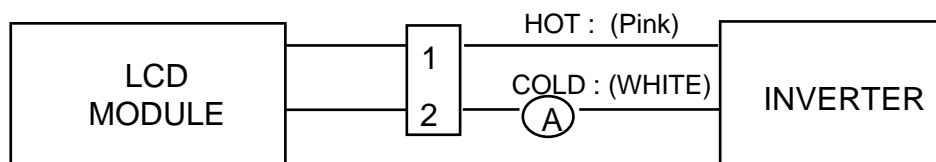

SEM SIC130T

SIC Inverter Switching Frequency :Typ 60KHz

(2) Lamp frequency may produce interference with horizontal synchronous frequency and this may cause line flow on the display. Therefore lamp frequency should be detached from the horizontal synchronous frequency and its harmonics as far as possible in order to avoid interference.

(3) refer to I<sub>L</sub> × V<sub>L</sub> to calculate.

(4) Life time (Hr) of a lamp can be defined as the time in which it continues to operate under the condition Ta = 25 ± 2 °C and I<sub>L</sub> = 6.0 mArms until one of the following event occurs.

1. When the brightness becomes 50% or lower than the original.

(5) The voltage above this value should be applied to the lamp for more than 1 second to startup. Otherwise the lamp may not be turned on.

(6) The minimum duty ratio of inverter should become more than 15%

## 4. BLOCK DIAGRAM

### 4.1 TFT LCD Module

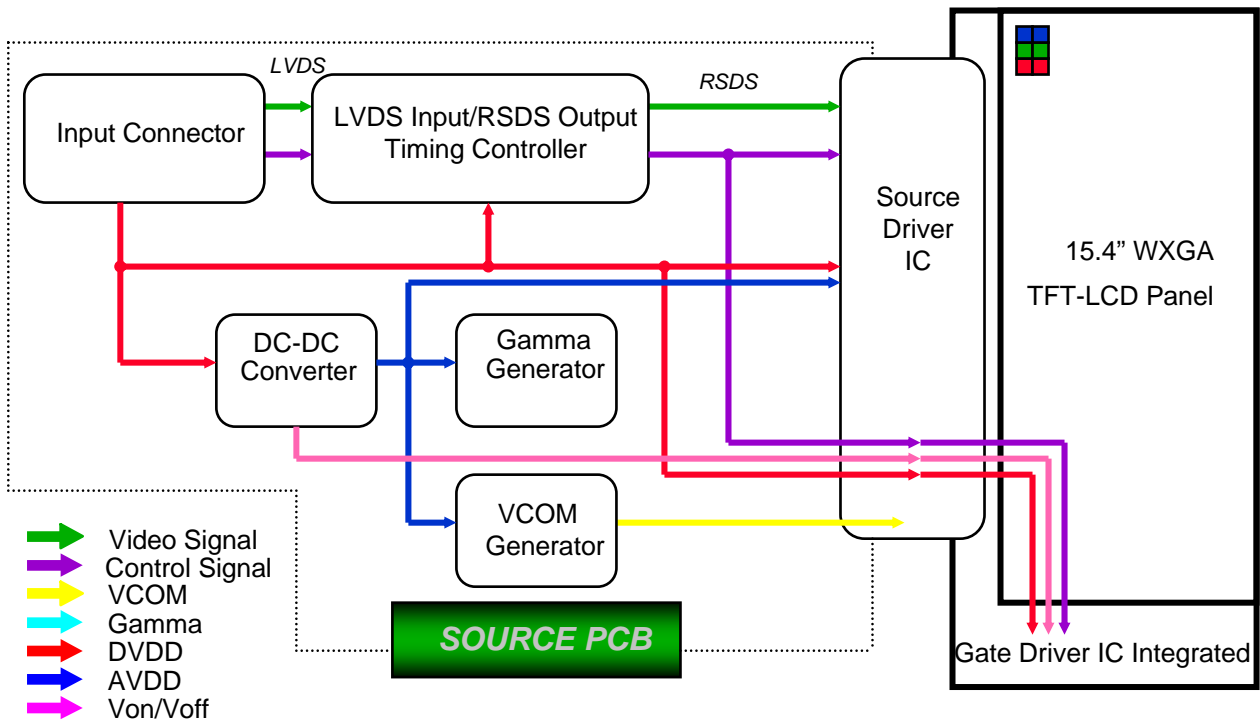

### 4.2 BACK-LIGHT UNIT

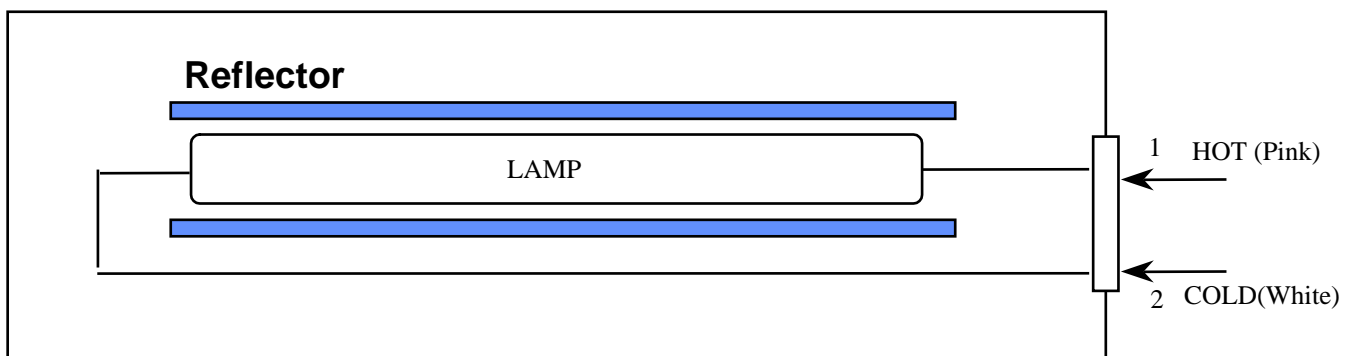

Connector : BHSR-02VS-1

Note) The output of the inverter may change according to the material of the reflector.

## 5. INPUT TERMINAL PIN ASSIGNMENT

5.1. Input Signal & Power LVDS, Connector : JAE, FI-XB30SRL-HF11-S  
Mating Connector : JAE, FI-X30M or Compatible

PIN NO	SYMBOL	FUNCTION	POLARITY	REMARK
1	VSS	Ground		
2	VDD	POWER SUPPLY +3.3V		
3	VDD	POWER SUPPLY +3.3V		
4	VEEDID	DDC 3.3V Power		
5	NC	No Connection		
6	CLKEDID	DDC Clock		
7	DATAEDID	DDC data		
8	RxIN0-	LVDS Differential Data INPUT (R0-R5,G0)	Negative	
9	RxIN0+	LVDS Differential Data INPUT (R0-R5,G0)	Positive	
10	VSS	Ground		
11	RxIN1-	LVDS Differential Data INPUT (G1-G5,B0-B1)	Negative	
12	RxIN1+	LVDS Differential Data INPUT (G1-G5,B0-B1)	Positive	
13	VSS	Ground		
14	RxIN2-	LVDS Differential Data INPUT (B1-B5,Sync,DE)	Negative	
15	RxIN2+	LVDS Differential Data INPUT (B1-B5,Sync,DE)	Positive	
16	VSS	Ground		
17	RxCLK-	LVDS Differential Data INPUT (Clock)	Negative	
18	RxCLK+	LVDS Differential Data INPUT (Clock)	Positive	
19	VSS	Ground		
20	NC	No Connection		
21	NC	No Connection		
22	NC	No Connection		
23	NC	No Connection		
24	NC	No Connection		
25	NC	No Connection		
26	NC	No Connection		
27	NC	No Connection		
28	NC	No Connection		
29	NC	No Connection		
30	NC	No Connection		

5.2 LVDS Transmitter : Transmitter **DS90CF383** or Compatible

Pin No.	Name	RGB Signal	Pin No.	Name	RGB Signal
51	TxIN0	R0	14	TxIN14	G5
52	TxIN1	R1	15	TxIN15	B0
54	TxIN2	R2	19	TxIN18	B1
55	TxIN3	R3	20	TxIN19	B2
56	TxIN4	R4	22	TxIN20	B3
3	TxIN6	R5	23	TxIN21	B4
4	TxIN7	G0	24	TxIN22	B5
6	TxIN8	G1	27	TxIN24	Hsync
7	TxIN9	G2	28	TxIN25	Vsync
11	TxIN12	G3	30	TxIN26	DE
12	TxIN13	G4	31	TxCLKIN	Clock

**FLAT LINK INTERFACE**

JAE, FI-XB30SRL-HF11-S

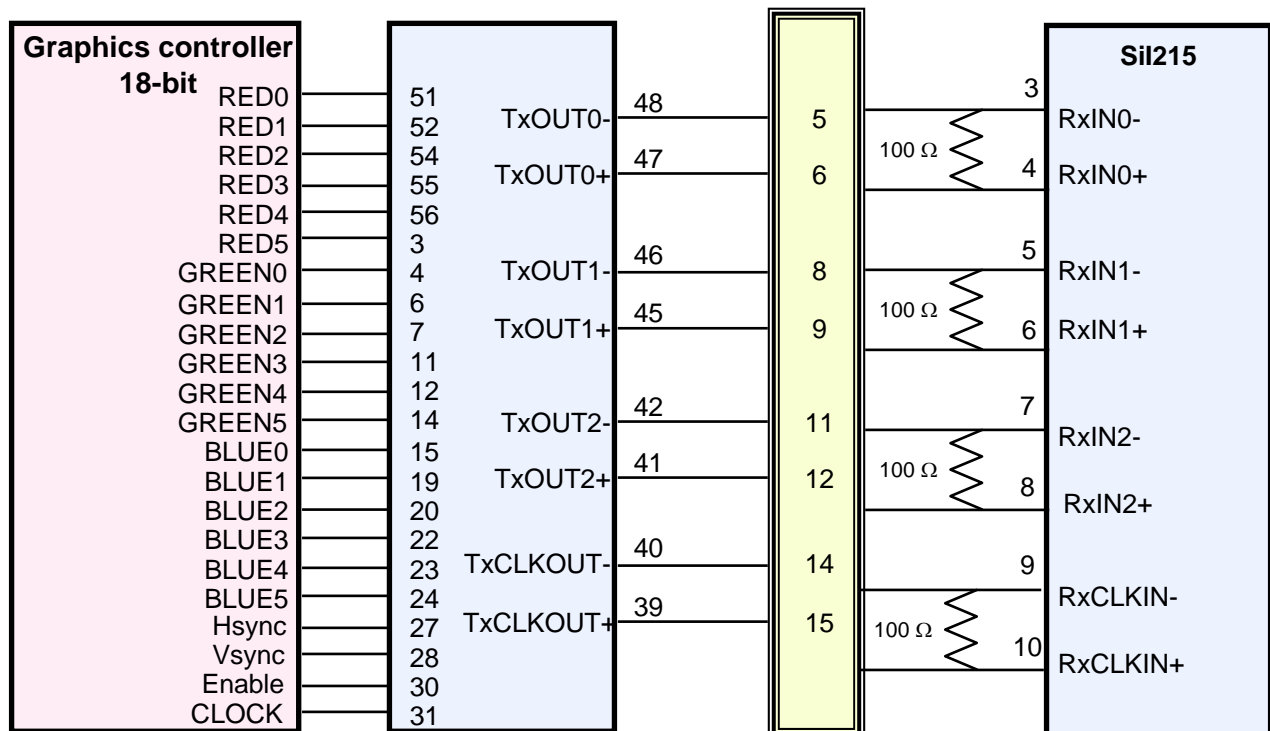

Note : The LCD Module uses a 100ohm resistor between positive and negative lines of each receiver input.



### 5.3 BACK LIGHT UNIT

Connector : JST BHSR - 02VS -1  
 Mating Connector : SM02B-BHSS-1(JST)

Pin NO.	Symbol	Color	Function
1	HOT	Pink	High Voltage
2	COLD	White	Low Voltage

### 5.4 Timing Diagrams of LVDS For Transmission

LVDS Receiver : Integrated T-CON

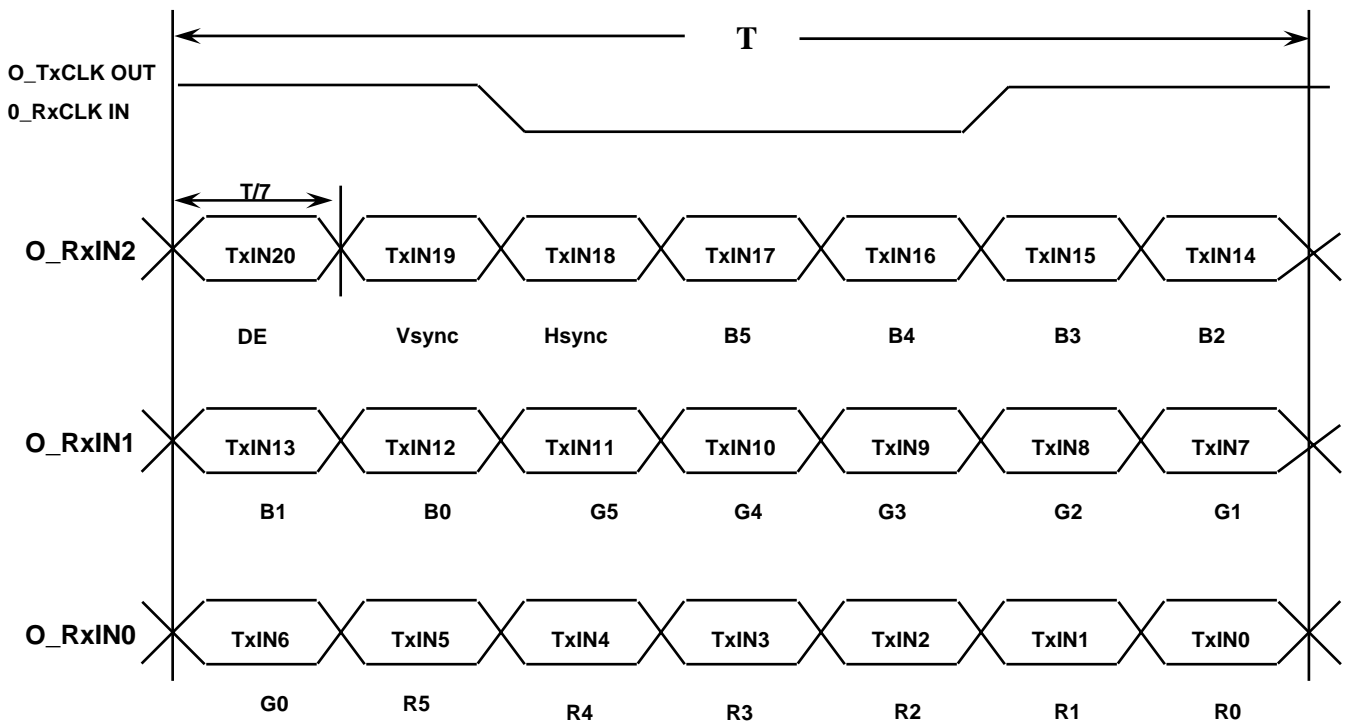

5.5 Input Signals, Basic Display Colors and Gray Scale of Each Color

Approval

Color	Display	Data Signal																	Gray Scale Level
		Red					Green					Blue							
		R0	R1	R2	R3	R4	R5	G0	G1	G2	G3	G4	G5	B0	B1	B2	B3	B4	
Basic Colors	Black	0	0	0	0	0	0	0	0	0	0	0	0	0	0	0	0	0	-
	Blue	0	0	0	0	0	0	0	0	0	0	0	0	1	1	1	1	1	-
	Green	0	0	0	0	0	0	1	1	1	1	1	1	0	0	0	0	0	-
	Cyan	0	0	0	0	0	0	1	1	1	1	1	1	1	1	1	1	1	-
	Red	1	1	1	1	1	1	0	0	0	0	0	0	0	0	0	0	0	-
	Magenta	1	1	1	1	1	1	0	0	0	0	0	0	1	1	1	1	1	-
	Yellow	1	1	1	1	1	1	1	1	1	1	1	1	0	0	0	0	0	-
	White	1	1	1	1	1	1	1	1	1	1	1	1	1	1	1	1	1	-
Gray Scale Of Red	Black	0	0	0	0	0	0	0	0	0	0	0	0	0	0	0	0	0	R0
	Dark	1	0	0	0	0	0	0	0	0	0	0	0	0	0	0	0	0	R1
	↑	0	1	0	0	0	0	0	0	0	0	0	0	0	0	0	0	0	R2
	:	:	:	:	:	:	:	:	:	:	:	:	:	:	:	:	:	:	R3~R60
	:	:	:	:	:	:	:	:	:	:	:	:	:	:	:	:	:	:	
	↓	1	0	1	1	1	1	0	0	0	0	0	0	0	0	0	0	0	R61
	Light	0	1	1	1	1	1	0	0	0	0	0	0	0	0	0	0	0	R62
	Red	1	1	1	1	1	1	0	0	0	0	0	0	0	0	0	0	0	R63
Gray Scale Of Green	Black	0	0	0	0	0	0	0	0	0	0	0	0	0	0	0	0	0	G0
	Dark	0	0	0	0	0	0	1	0	0	0	0	0	0	0	0	0	0	G1
	↑	0	0	0	0	0	0	0	1	0	0	0	0	0	0	0	0	0	G2
	:	:	:	:	:	:	:	:	:	:	:	:	:	:	:	:	:	:	G3~G60
	:	:	:	:	:	:	:	:	:	:	:	:	:	:	:	:	:	:	
	↓	0	0	0	0	0	0	1	0	1	1	1	1	0	0	0	0	0	G61
	Light	0	0	0	0	0	0	0	1	1	1	1	1	0	0	0	0	0	G62
	Green	0	0	0	0	0	0	1	1	1	1	1	1	0	0	0	0	0	G63
Gray Scale Of Blue	Black	0	0	0	0	0	0	0	0	0	0	0	0	0	0	0	0	0	B0
	Dark	0	0	0	0	0	0	0	0	0	0	0	0	1	0	0	0	0	B1
	↑	0	0	0	0	0	0	0	0	0	0	0	0	0	1	0	0	0	B2
	:	:	:	:	:	:	:	:	:	:	:	:	:	:	:	:	:	:	B3~B60
	:	:	:	:	:	:	:	:	:	:	:	:	:	:	:	:	:	:	
	↓	0	0	0	0	0	0	0	0	0	0	0	0	1	0	1	1	1	B61
	Light	0	0	0	0	0	0	0	0	0	0	0	0	0	1	1	1	1	B62
	Blue	0	0	0	0	0	0	0	0	0	0	0	0	1	1	1	1	1	B63

Note 1) Definition of gray :

Rn: Red gray, Gn: Green gray, Bn: Blue gray (n=gray level)

Note 2) Input signal: 0 =Low level voltage, 1=High level voltage

5.6 Pixel Format in the display

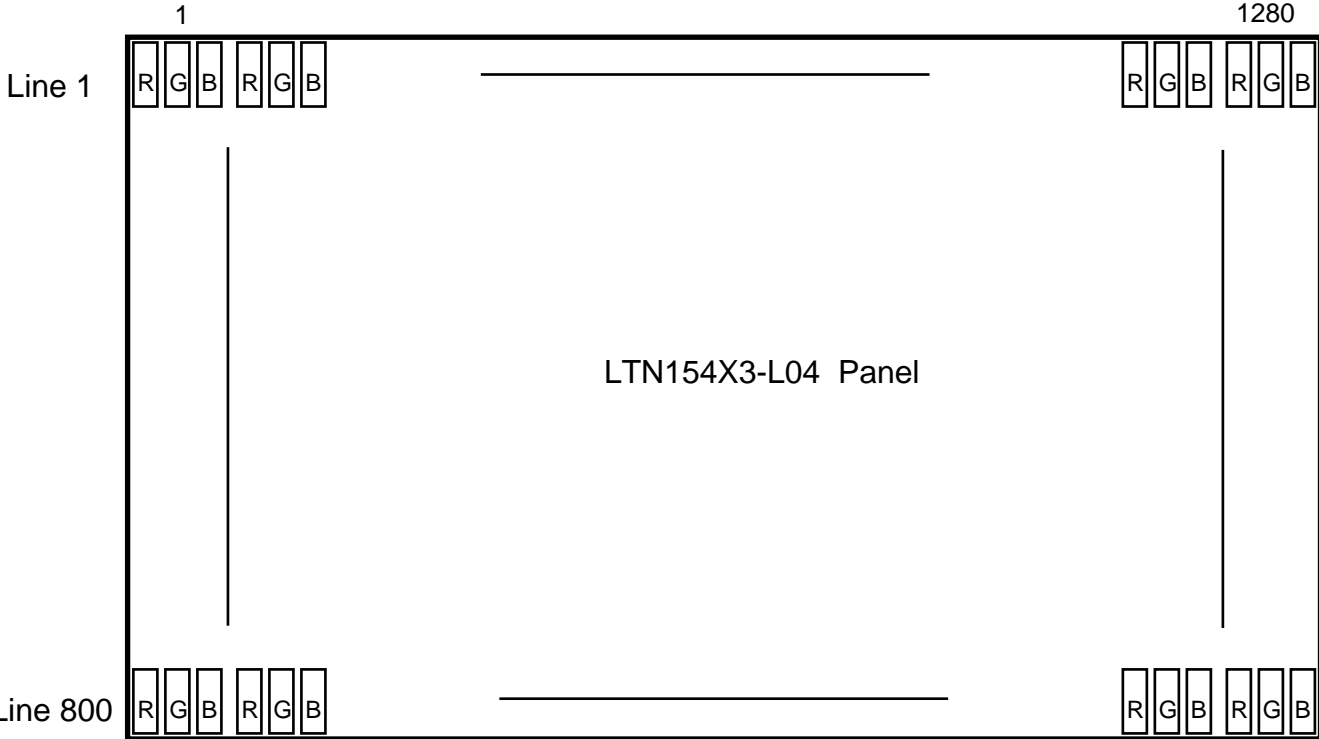

## 6. INTERFACE TIMING

Approval

### 6.1 Timing Parameters

Signal	Item	Symbol	Min.	Typ.	Max.	Unit	Note
Frame Frequency	Cycle	TV	773	823	1000	Lines	-
Vertical Active Display Term	Display Period	TVD	-	800	-	Lines	-
One Line Scanning Time	Cycle	TH	1315	1440	1750	Clocks	-
Horizontal Active Display Term	Display Period	THD	-	1280	-	Clocks	-
Vertical Blank Term	Cycle	Vblank		6		lines	
Horizontal Blank Term	Cycle	Hblank		32		clocks	

### 6.2 Timing diagrams of interface signal

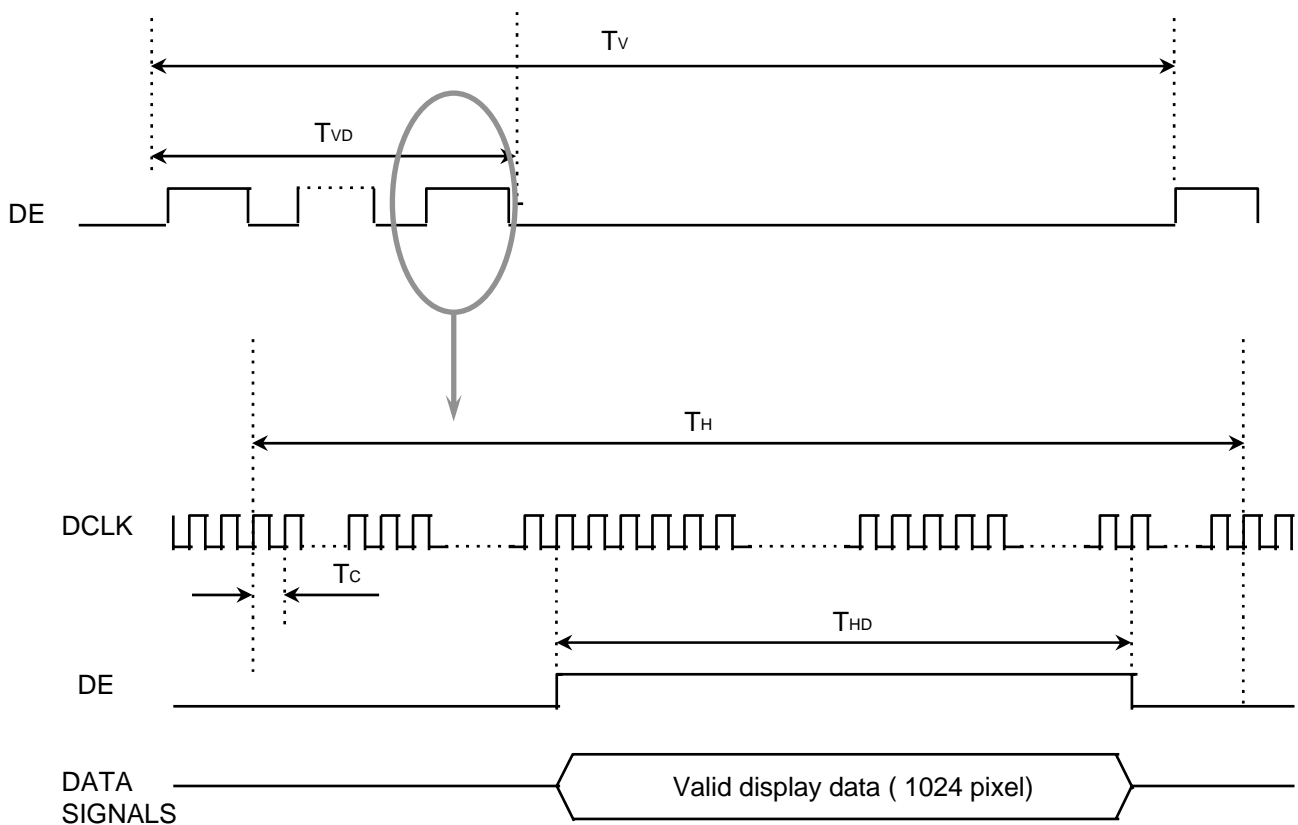

### 6.3 Power ON/OFF Sequence

: To prevent a latch-up or DC operation of the LCD module, the power on/off sequence shall be as shown below.

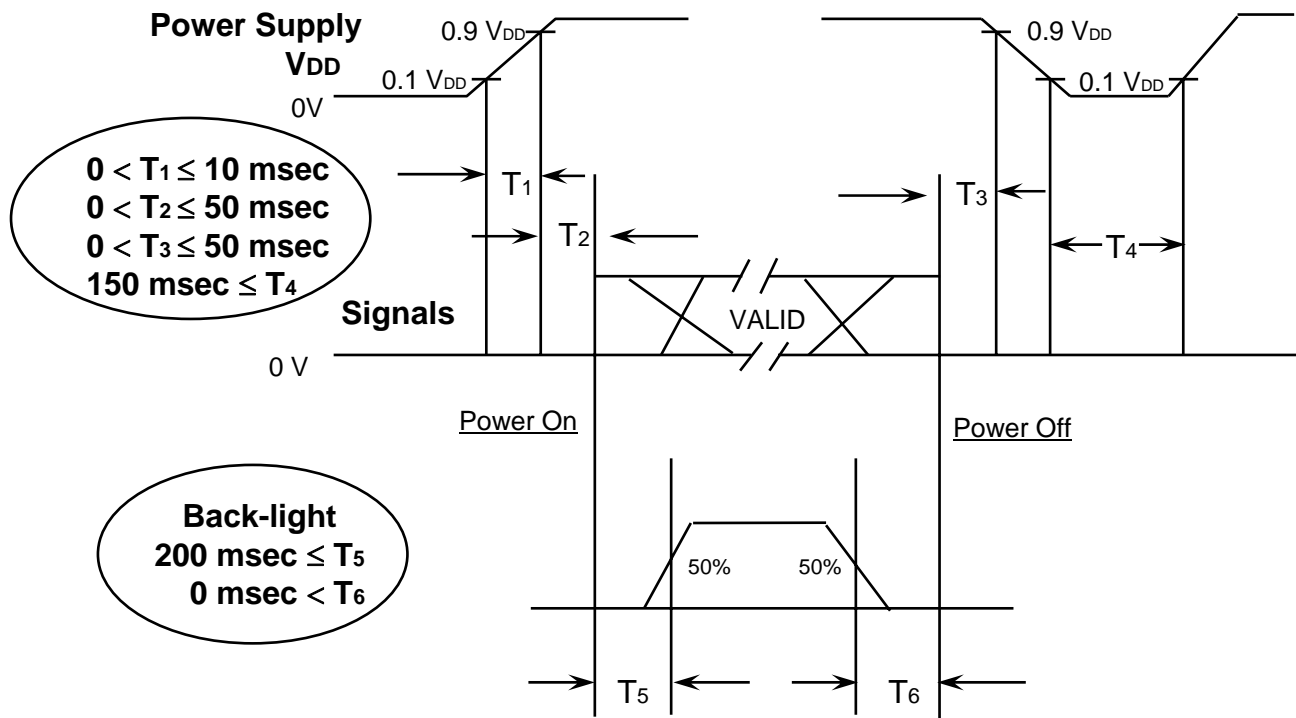

#### Power ON/OFF Sequence

- T1 : Vdd rising time from 10% to 90%
- T2 : The time from Vdd to valid data at power ON.
- T3 : The time from valid data off to Vdd off at power Off.
- T4 : Vdd off time for Windows restart
- T5 : The time from valid data to B/L enable at power ON.
- T6 : The time from valid data off to B/L disable at power Off.

#### NOTE.

- (1) The supply voltage of the external system for the module input should be the same as the definition of V<sub>DD</sub>.
- (2) Apply the lamp voltage within the LCD operation range. When the backlight turns on before the LCD operation or the LCD turns off before the backlight turns off, the display may momentarily become white.
- (3) In case of V<sub>DD</sub> = off level, please keep the level of input signals on the low or keep a high impedance.
- (4) T<sub>4</sub> should be measured after the module has been fully discharged between power off and on period.
- (5) Interface signal shall not be kept at high impedance when the power is on.

## 7. Mechanical Outline Dimension

Approval

*[ Refer to the section 5.9 ]*



## 8. Product Markings and Others

A nameplate bearing followed by is affixed to a shipped product at the specified location on each product.

- (1) Parts number : LTN154X3-L04
- (2) Revision : One letter
- (3) Control code : One letter
- (4) Lot number : 4 F D 005 04 02

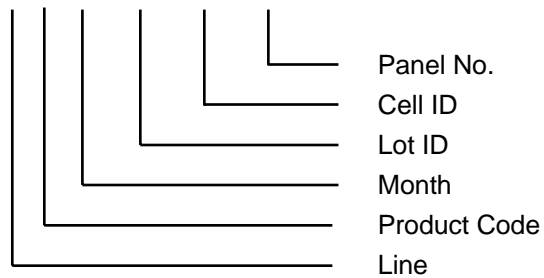

NOTE 1). This code indicating year is omitted in the products of Chun-an site.

### (5) Product Label Definition



TFT-LCD Product name	: LTN154X3 – L04
Lot number	: 4FD0050402
Revision Code	: 000
Inspected work week	: 0526(2005 Year, 26 <sup>th</sup> week)
P/N	: Lenovo Part Number (13N7015)
EC NO	: Engineering Change Number (Blank)
FRU	: Field Replaceable Unit Part Number(13N7016)
Header Code	: 1ZB4N



## 9. GENERAL PRECAUTIONS

### 1. Handling

- (a) When the module is assembled, It should be attached to the system firmly using selected mounting holes. Be careful not to twist and bend the modules.
- (b) Refrain from strong mechanical shock and / or any force to the module. In addition to damage, this may cause improper operation or damage to the module and CCFT backlight.
- (c) Note that polarizers are very fragile and could be easily damaged. Do not press or scratch the surface harder than a HB pencil lead.
- (d) Wipe off water droplets or oil immediately. If you leave the droplets for a long time, Staining and discoloration may occur.
- (e) If the surface of the polarizer is dirty, clean it using some absorbent cotton or soft cloth.
- (f) The desirable cleaners are water, IPA(Isoprophyl Alcohol) or Hexane. Do not use Ketone type materials(ex. Acetone), Ethyl alcohol, Toluene, Ethyl acid or Methyl chloride. It might permanent damage to the polarizer due to chemical reaction.
- (g) If the liquid crystal material leaks from the panel, it should be kept away from the eyes or mouth . In case of contact with hands, legs or clothes, it must be washed away thoroughly with soap.
- (h) Protect the module from static , it may cause damage to the C-MOS Gate Array IC.
- (i) Use fingerstalls with soft gloves in order to keep display clean during the incoming inspection and assembly process.
- (j) Do not disassemble the module.
- (k) Do not pull or fold the lamp wire.
- (l) Do not adjust the variable resistor which is located on the back side.
- (m) Protection film for polarizer on the module shall be slowly peeled off just before use so that the electrostatic charge can be minimized.
- (n) Pins of I/F connector shall not be touched directly with bare hands.

## 2. STORAGE

- (a) Do not leave the module in high temperature, and high humidity for a long time. It is highly recommended to store the module with temperature from 0 to 35°C and relative humidity of less than 70%.
- (b) Do not store the TFT-LCD module in direct sunlight.
- (c) The module shall be stored in a dark place. It is prohibited to apply sunlight or fluorescent light during the store.

## 3. OPERATION

- (a) Do not connect, disconnect the module in the “ Power On” condition.
- (b) Power supply should always be turned on/off by following item 6.3 “ Power on/off sequence “.
- (c) Module has high frequency circuits. Sufficient suppression to the electromagnetic interference shall be done by system manufacturers. Grounding and shielding methods may be important to minimize the interference.
- (d) The cable between the backlight connector and its inverter power supply shall be a minimized length and be connected directly . The longer cable between the backlight and the inverter may cause lower luminance of lamp(CCFT) and may require higher startup voltage(Vs).

## 4. OTHERS

- (a) Ultra-violet ray filter is necessary for outdoor operation.
- (b) Avoid condensation of water. It may result in improper operation or disconnection of electrode.
- (c) Do not exceed the absolute maximum rating value. ( the supply voltage variation, input voltage variation, variation in part contents and environmental temperature, so on) Otherwise the module may be damaged.
- (d) If the module displays the same pattern continuously for a long period of time, it can be the situation when the image “sticks” to the screen.
- (e) This module has its circuitry PCB's on the rear side and should be handled carefully in order not to be stressed.

# 10. EDID

Approval

Address (HEX)	FUNCTION	Value	BIN	DEC	ASCII or Data	Notes
		HEX				
00	Header	00	00000000	0		EDID Header
01		FF	11111111	255		
02		FF	11111111	255		
03		FF	11111111	255		
04		FF	11111111	255		
05		FF	11111111	255		
06		FF	11111111	255		
07		00	00000000	0		
08	ID Manufacturer Name	24	00100100	36	I B M	3 character ID
09		4D	01001101	77	M	"IBM" as an end-customer
0A	ID Product Code	73	01110011	115	[s]	
0B		23	00100011	35	[#]	
0C	32-bit serial no.	00	00000000	0		
0D		00	00000000	0		
0E		00	00000000	0		
0F		00	00000000	0		
10	Week of manufacture	00	00000000	0		
11	Year of manufacture	0F	00001111	15	2005	2005
12	EDID Structure Ver.	01	00000001	1	1	EDID Ver. 1.0
13	EDID revision #	03	00000011	3	3	EDID Rev. 3
14	Video input definition	80	10000000	128		
15	Max H image size	21	00100001	33	33	33 cm(approx)
16	Max V image size	15	00010101	21	21	21 cm(approx)
17	Display Gamma	78	01111000	120	2.2	Gamma 2.2
18	Feature support	0A	00001010	10		
19	Red/green low bits	87	10000111	135		10000111
1A	Blue/white low bits	F5	11110101	245		11111110
1B	Red x/ high bits	94	10010100	148	0.580	Red x 0.580= 1001010010
1C	Red y	57	01010111	87	0.340	Red y 0.340= 0101011100
1D	Green x	4F	01001111	79	0.310	Green x 0.310= 0100111101
1E	Green y	8C	10001100	140	0.550	Green y 0.550= 1000110011
1F	Blue x	27	00100111	39	0.155	Blue x 0.155= 0010011111
20	Blue y	27	00100111	39	0.155	Blue y 0.155= 0010011111
21	White x	50	01010000	80	0.313	White x 0.313= 0101000001
22	White y	54	01010100	84	0.329	White y 0.329= 0101010001
23	Established timing 1	00	00000000	0		
24	Established timing 2	00	00000000	0		
25	Established timing 3	00	00000000	0		
26	Standard timing #1	01	00000001	1		not used
27		01	00000001	1		
28	Standard timing #2	01	00000001	1		not used
29		01	00000001	1		
2A	Standard timing #3	01	00000001	1		not used
2B		01	00000001	1		
2C	Standard timing #4	01	00000001	1		not used
2D		01	00000001	1		
2E	Standard timing #5	01	00000001	1		not used
2F		01	00000001	1		
30	Standard timing #6	01	00000001	1		not used
31		01	00000001	1		
32	Standard timing #7	01	00000001	1		not used
33		01	00000001	1		
34	Standard timing #8	01	00000001	1		not used
35		01	00000001	1		

36	Detailed timing/monitor descriptor #1	C7	11000111	199	71.11	Main clock= 71.11 MHz (@60Hz)	
37		1B	00011011	27			
38		00	00000000	0	1280		Hor active=640*2 pixels
39		A0	10100000	160	160		Hor blanking=160 pixels
3A		50	01010000	80			4bit : 4bit
3B		20	00100000	32	800		Vertical active=800 lines
3C		17	00010111	23	23		Vertical blanking=23 lines
3D		30	00110000	48			4bit : 4bit
3E		30	00110000	48	48		Hor sync. Offset=48 pixels
3F		20	00100000	32	32		H sync. Width=32 pixels
40		36	00110110	54	3 6		V sync. Offset=3 lines V sync. Width=6 lines
41		00	00000000	0			2bit : 2bit :2bit :2bit
42		4B	01001011	75	331		H image size= 331 mm(approx)
43		CF	11001111	207	207		V image size = 207 mm(approx)
44	10	00010000	16				
45	00	00000000	0		No Horizontal Border		
46	00	00000000	0		No Vertical Border		
47	19	00011001	25				
48	Detailed timing/monitor descriptor #2	26	00100110	38	59.26	Main clock= 59.26 MHz (@50Hz)	
49		17	00010111	23			
4A		00	00000000	0	1280		Hor active=640*2 pixels
4B		A0	10100000	160	160		Hor blanking=160 pixels
4C		50	01010000	80			4bit : 4bit
4D		20	00100000	32	800		Vertical active=800 lines
4E		17	00010111	23	23		Vertical blanking=23 lines
4F		30	00110000	48			4bit : 4bit
50		30	00110000	48	48		Hor sync. Offset=48 pixels
51		20	00100000	32	32		H sync. Width=32 pixels
52		36	00110110	54	3 6		V sync. Offset=3 lines V sync. Width=6 lines
53		00	00000000	0			2bit : 2bit :2bit :2bit
54		4B	01001011	75	331		H image size= 331 mm(approx)
55		CF	11001111	207	207		V image size = 207 mm(approx)
56	10	00010000	16				
57	00	00000000	0		No Horizontal Border		
58	00	00000000	0		No Vertical Border		
59	19	00011001	25				
5A	descriptor #3	00	00000000	0		Manufacturer Specified (Timing)	
5B		00	00000000	0			
5C		00	00000000	0			
5D		0F	00001111	15			
5E		00	00000000	0			
5F		81	10000001	129			(Horizontal active pixel /8)-31
60		0A	00001010	10			Image Aspect Ratio(16:10)
61		32	00110010	50			Low Refresh Rate #1(50Hz)
62		81	10000001	129			(Horizontal active pixel /8)-31
63		0A	00001010	10			Image Aspect Ratio(16:10)
64		28	00101000	40			Low Refresh Rate #1(40Hz)
65		14	00010100	20			Brightness(1/10nit)
66		01	00000001	1			Feature flag(TN mode)
67		00	00000000	0			
68	4C	01001100	76		supplier ID "SEC"		
69	A3	10100011	163				
6A	58	01011000	88	X	Product code "X3"		
6B	33	00110011	51	3	(Hex, LSB first)		

6C	Detailed timing/monitor descriptor #4	00	00000000	0		Monitor Name Tag (ASCII)
6D		00	00000000	0		
6E		00	00000000	0		
6F		FE	11111110	254		
70		00	00000000	0		
71		4C	01001100	76	[L]	
72		54	01010100	84	[T]	
73		4E	01001110	78	[N]	
74		31	00110001	49	[1]	
75		35	00110101	53	[5]	
76		34	00110100	52	[4]	
77		58	01011000	88	[X]	
78		33	00110011	51	[3]	
79		2D	00101101	45	[-]	
7A		4C	01001100	76	[L]	
7B	30	00110000	48	[0]		
7C	34	00110100	52	[4]		
7D	0A	00001010	10	[*]		
7E	Extension Flag	00	00000000	0		
7F	Checksum	0B	00001011	11		