



ELECTRONICS

Product Information

ISSUE DATE : 2005-5-9

MODEL : LTM240M1-L01

Note : This Product information is subject to change after 3 months of issuing date

Prepared by : LCD Buisness Technical Customer Service Team

Samsung Electronics Co . , LTD.



Contents

General Description	-----	(3)
1. Absolute Maximum Ratings	-----	(4)
1.1 Absolute Ratings Of Environment		
1.2 Electrical Absolute Ratings		
2. Optical Characteristics	-----	(6)
3. Electrical Characteristics	-----	(10)
3.1 TFT LCD Module		
3.2 Back-light Unit		
4. Block Diagram	-----	(14)
4.1 TFT LCD Module		
4.2 Back-light Unit		
5. Input Terminal Pin Assignment	-----	(15)
5.1 Input Signal		
5.2 Open LDI LVDS Interface		
5.3 Input Power		
5.4 Back-light Unit		
5.5 Input Signals, Basic Display Colors and Gray Scale of Each Color		
6. Interface Timing	-----	(19)
6.1 Timing Parameters (DE only mode)		
6.2 Timing Diagrams of interface Signal (DE only mode)		
6.3 Power ON/OFF Sequence		
6.4 V _{DD} Power Dip Condition		
6.5 LVDS Input Characteristics		
7. Outline Dimension	-----	(25)
8. General Precaution	-----	(27)
8.1 Handling		
8.2 Storage		
8.3 Operation		
8.4 Others		

General Description

* Description

LTM240M1-L01 is a color active matrix TFT (Thin Film Transistor) liquid crystal display (LCD) that uses amorphous silicon TFTs as switching devices. This model is composed of a TFT LCD panel, a driver circuit and a back-light system. The resolution of a 24.0" contains 1920 x 1200 pixels and can display up to 16.7 million colors with wide viewing angle of 89° in all directions. (Vertical viewing angle : 178°, Horizontal viewing angle : 178°)

* Features

- High contrast ratio, high aperture structure
- APVA(Advanced Patterned Vertical Alignment) Mode
- Wide viewing angle($\pm 178^\circ$)
- High speed response
- WUXGA(1920 x 1200 pixels) resolution
- Low Power consumption
- 6 U-type CCFTs (Cold Cathode Fluorescent Tube)
- DE only mode
- Open LDI (LVDS Display Interface) : DS90CF388
- Pb-free configuration

* Applications

- Workstation & desktop monitors
 - Display terminals for AV application products
 - Monitors for industrial machine and medical appliances
- * If the module is used to other applications besides the above, please contact SEC in advance.

* General information

Items	Specification	Unit	Note
Display area	518.4(H) x324.0(V)	mm	
Driver element	a-Si TFT active matrix		
Display colors	16.7M(true 8-bit)	colors	
Number of pixels	1920 x 1200	pixel	
Pixel arrangement	RGB vertical stripe		
Pixel pitch	0.270(H) x 0.270(W)	mm	
Display mode	Normally Black		
Surface treatment	Haze 25%, Hard - coating (3H)		

*** Mechanical information**

Item		Min.	Typ.	Max.	Note
Module size	Horizontal(H)	-	546.4	-	mm
	Vertical(V)	-	352.0	-	mm
	Depth(D)	-	-	36.3	mm
Weight		-	-	3,550	g

1. Absolute Maximum Ratings

1.1 Absolute ratings of environment

Item	Symbol	Min.	Max.	Unit	Note
Storage temperature	T _{STG}	-20	65		(1)
Operating temperature (Glass surface temperature)	T _{OPR}	0	50		(1)
Shock (non - operating)	Snop	-	50	G	(2),(4)
Vibration (Non - operating)	Vnop	-	1.0	G	(3),(4)

Note

- (1) Temperature and relative humidity range are shown in the figure below.
90 % RH Max. (40 °C ≥ Ta)
Maximum wet-bulb temperature at 39 °C or less. (Ta > 40 °C) No condensation.
- (2) 11ms, sine wave, 1 time for ±X, ±Y, ±Z axis
- (3) 10-300 Hz, Sweep rate 10min, 30min for X,Y,Z axis
- (4) At testing Vibration and Shock, the fixture in holding the Module to be tested have to be hard and rigid enough so that the Module would not be twisted or bent by the fixture.

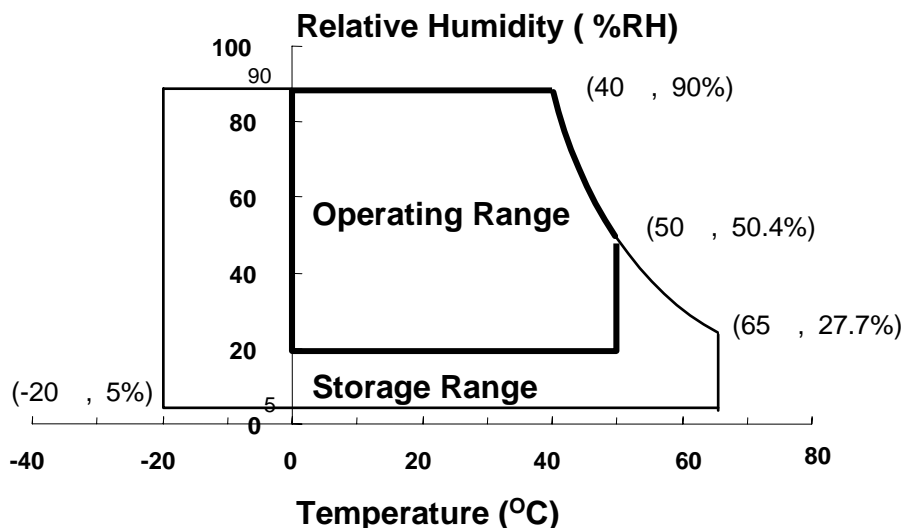

1.2 ELECTRICAL ABSOLUTE RATINGS

(1) TFT LCD Module

(V_{SS} = GND = 0 V)

Item	Symbol	Min.	Max.	Unit	Note
Power Supply Voltage	V _{DD}	V _{SS} -0.5	6.5	V	(1)

NOTE (1) Within Ta (25 ± 2 °C)

(2) BACK-LIGHT UNIT

(Ta = 25 ± 2°C)

Item	Symbol	Min.	Max.	Unit.	Note
Lamp Current	I _L	4.0	7.0	mArms	(1),(2)
Lamp Frequency	F _L	40	80	kHz	(1)

NOTE (1) Permanent damage to the device may occur if maximum values are exceeded. Functional operation should be restricted to the conditions described under Normal Operating Conditions.

(2) Specified values are for a single lamp.

(Refer to the Note (1) in the page 12 for further information.)

2. Optical Characteristics

The following items are measured under stable conditions. The optical characteristics should be measured in a dark room or equivalent state with the methods shown in Note (1).

Measuring equipment : TOPCON BM-5A , BM-7, PHOTO RESEARCH PR650
Eldim EZ-Contrast

(Inverter Freq. : 50kHz) * Ta = 25 ± 2°C , VDD=5V, fv= 60Hz, fDCLK= 77MHz, IL = 6.0mA_{rms}

Item	Symbol	Condition	Min.	Typ.	Max.	Unit	Note		
Contrast Ratio (Center of screen)	C/R		-	1000	-		(3) BM-5A		
Response Time	On/Off	T _R +T _F	-	16	-	msec	(4) BM-7		
	G to G	T _{G-G,avg}	-	6	-				
		T _{G-G,long}	-	8	-				
Luminance of White (Center of screen)	YL		-	500	-	cd/m ²	(5) BM-5A		
Color Chromaticity (CIE 1931)	Red	R _x	Normal φ = 0 θ = 0 Viewing Angle	0.640	-	-	(6) PR650		
		R _y		0.330					
	Green	G _x		0.300					
		G _y		0.608					
	Blue	B _x		0.150					
		B _y		0.060					
	White	W _x		0.313					
		W _y		0.329					
Color Chromaticity (CIE 1976)	Red	R _u '	0.451	-	-	(6) PR650			
		R _v '	0.523						
	Green	G _u '	0.124						
		G _v '	0.564						
	Blue	B _u '	0.175						
		B _v '	0.158						
	White	W _u '	0.198						
		W _v '	0.468						
Viewing Angle	Hor.	θ L	-	89	-	Degrees	(7) Ez-Contrast		
		θ R	-	89	-				
	Ver.	φ H	-	89	-				
		φ L	-	89	-				
Viewing Angle	Hor.	θ L	-	75	-			Degrees	(7) Ez-Contrast
		θ R	-	75	-				
	Ver.	φ H	-	65	-				
		φ L	-	65	-				
Brightness Uniformity (9 points)	Buni		-	-	25	%	(8) BM-5A		

Note 1) Test Equipment Setup

The measurement should be executed in a stable, windless and dark room between 30min and 40min after lighting the back-light at the given temperature for stabilization of the back-light. This should be measured in the center of screen.

Single lamp current : 6.0mA (Refer to the note(1) in the page 12 for more information.)

Environment condition : $T_a = 25 \pm 2 \text{ } ^\circ\text{C}$

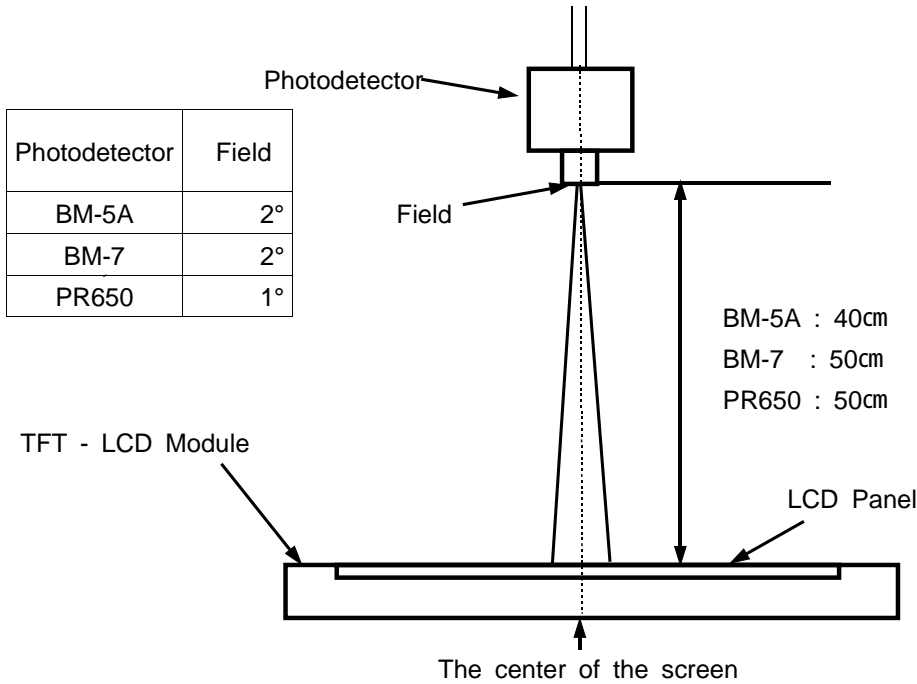

Optical Measuring Equipment Setup

Note 2) Definition of test point

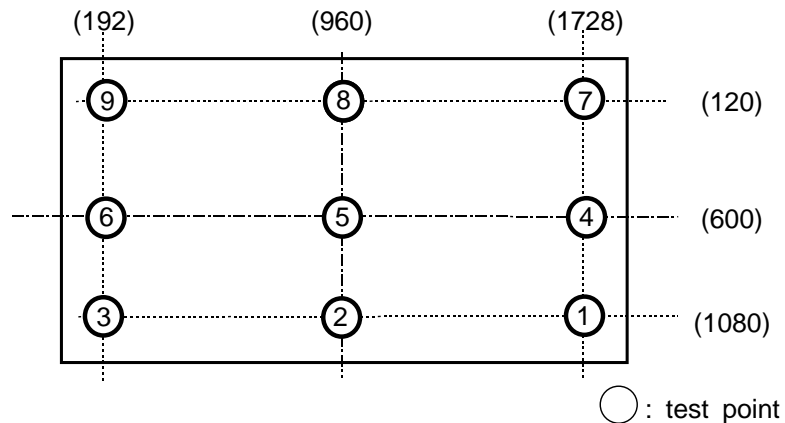

Note 3) Definition of Contrast Ratio (C/R) : Ratio of gray max (Gmax) & gray min (Gmin) at the center point of the panel

$$CR = \frac{G \text{ max}}{G \text{ min}}$$

Gmax : Luminance with all pixels white

Gmin : Luminance with all pixels black

Note 4) Definition of Response time : Sum of Tr ,Tf
on/off response time : sum of Tr, Tf

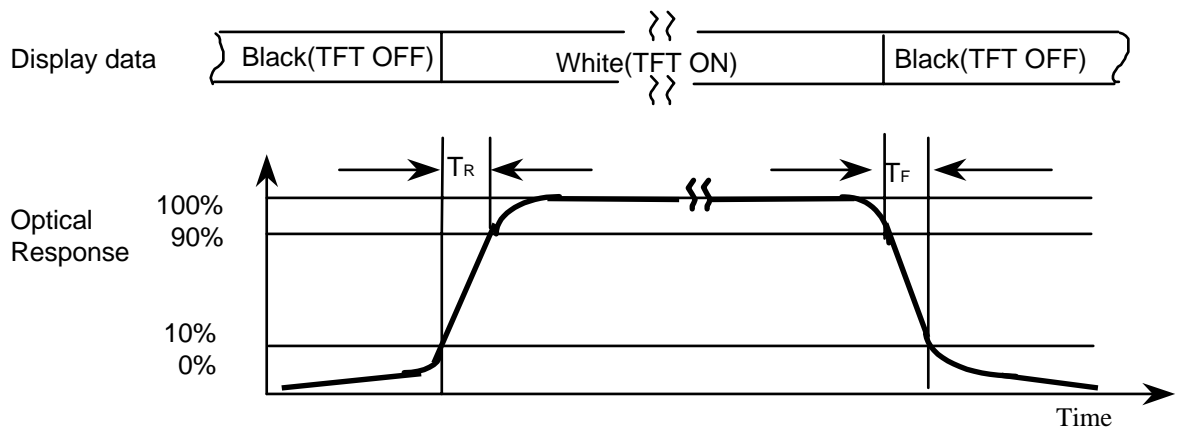

gray to gray response time

- measuring gray : 31 63, 63 95, 95 127, 127 159, 159 191, 191 223 grays and vice versa
- TG-G, avg : average response time of ones between above grays
- TG-G, long : the longest response time of ones between above grays

Note 5) Definition of Luminance of White : Luminance of white at center point

Note 6) Definition of Color Chromaticity (CIE 1931, CIE 1976)

Color coordinate of Red , Green , Blue & White at center point

Note 7) Definition of Viewing Angle : Viewing angle range (CR 10, CR 100)

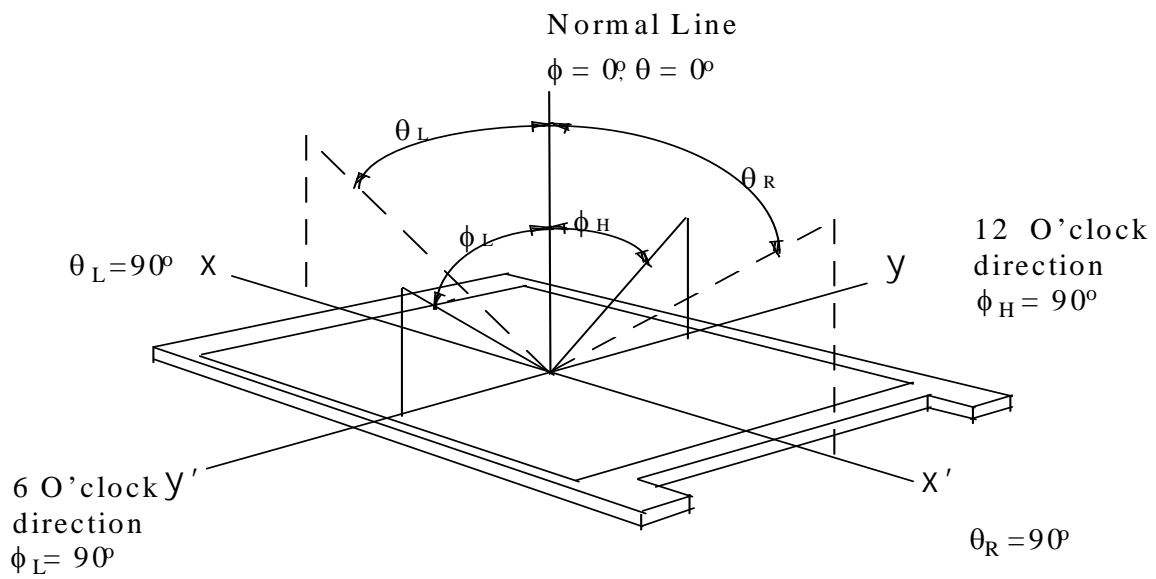

Note 8) Definition of 9 points brightness uniformity

$$Buni = 100 * \frac{(B_{max} - B_{min})}{B_{max}}$$

Bmax : Maximum brightness

Bmin : Minimum brightness

3. Electrical Characteristics

3.1 TFT LCD MODULE

Ta = 25°C

Item	Symbol	Min.	Typ.	Max.	Unit	Note	
Voltage of Power Supply	V _{DD}	4.5	5.0	5.5	V	(1)	
Interface type	LVDS	LVDS (DS90C387 Tx)					
Current of Power Supply	(a) Black	-	1700	-	mA	(2),(3)	
	(b) White	-	2000	-	mA		
	(c) Dot pattern	-	2400	3050	mA		
Vsync Frequency	f _v	57	60	60	Hz	2pxl/clock	
Hsync Frequency	f _H	69	74	77	kHz		
Main Frequency	f _{DCLK}	71.0	77.0	83.0	MHz		
Rush Current	I _{RUSH}	-	-	3.0	A	(4)	

Note (1) The connector for display data & timing signal should be connected.(V_{SS}=0V)

(2) f_v = 60Hz, f_{DCLK} = 77MHz, V_{DD} = 5.0V, DC Current.

(3) Power dissipation check pattern(LCD Module only)

a) Black Pattern



b) White Pattern



c) Dot pattern

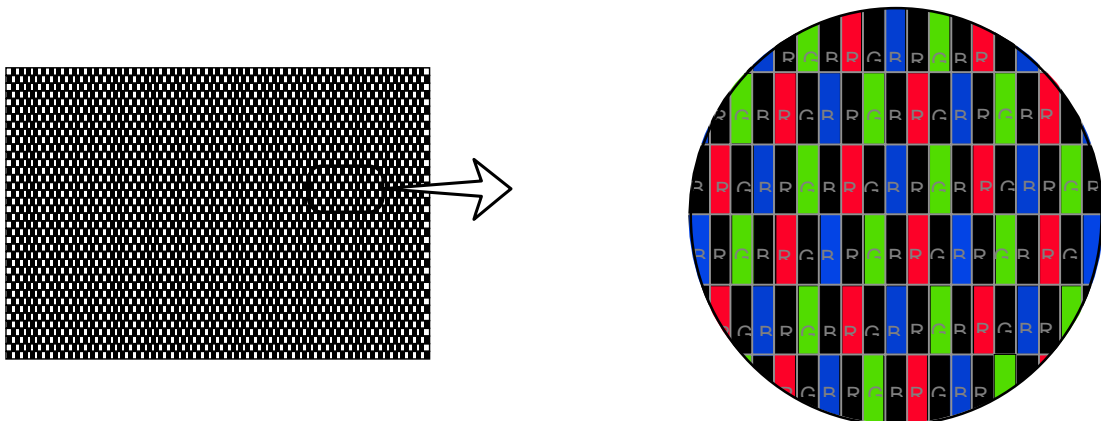

(4) Measurement Conditions

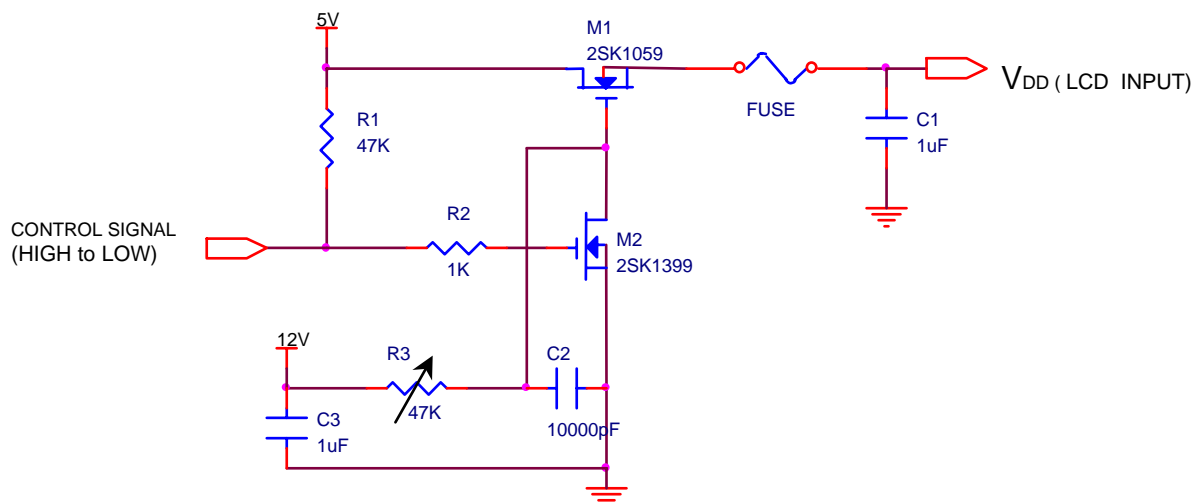

Note : Control Signal : High(+5V) Low(Ground)

All Signal lines to panel except for power 5V : Ground

The rising time of supplied voltage is controlled to 470us by R3 and C2 value.

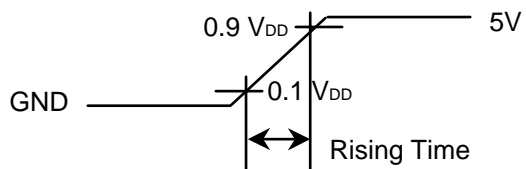

3.2 BACK-LIGHT UNIT

The back-light system is a direct lighting with U-type 6 CCFTs (Cold Cathode Fluorescent Tube). The characteristics of those lamps are shown in the following tables.

Ta=25 ± 2

Item	Symbol	Min.	Typ.	Max.	Unit	Note	
Lamp Current	I _L	4.0	6.0	7.0	mArms	(1)	
Lamp Voltage	V _L	-	1800	-	Vrms		
Lamp Frequency	f _L	40	-	60	kHz	(2)	
inverter waveform	asymmetry rate	W _{asy}	-	-	10	%	(5)
	distortion rate	W _{dis}	-	-	2 ±10	%	
Start up Voltage	V _s	-	-	0 : 3,540	Vrms	(3)	
				25 : 2,830			

Note) The waveform of the inverter output voltage must be area symmetric and the design of the inverter must have specifications for the modularized lamp.

The performance of the back-light, for example life time or brightness, is much influenced by the characteristics of the DC-AC inverter for the lamp. So all the parameters of an inverter should be carefully designed so as not to produce too much leakage current from high-voltage output of the inverter. When you design or order the inverter, please make sure that a poor lighting caused by the mismatch of the back-light and the inverter(miss lighting, flicker, etc.) never occur. When you confirm it, the module should be operated in the same condition as it is installed in your instrument.

Note (1) The lamp current is measured with current meter for high frequency as shown below.

Refer to the block diagram of the back-light unit in the next page for more information. Specified values are for a single lamp.

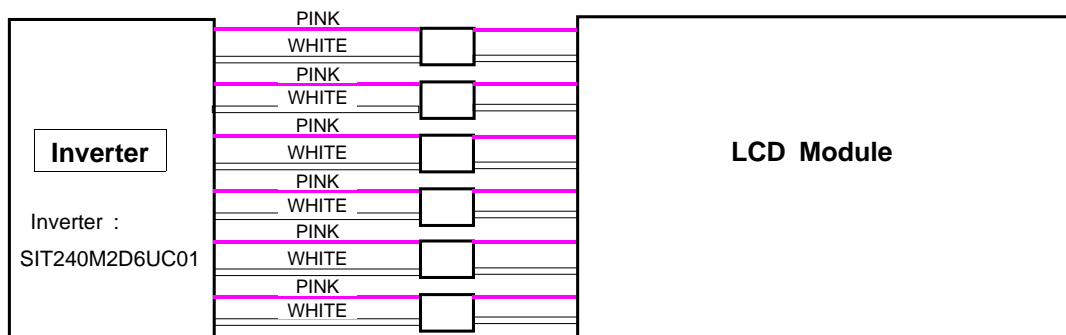

- (2) Lamp frequency may produce interference with horizontal synchronous frequency which may cause line flow on the display. Therefore lamp frequency should be detached from the horizontal synchronous frequency and its harmonics as far as possible in order to avoid interference.
- (3) If an inverter has shutdown function, it should keep its output for more than 1 second even if the lamp connector open. Otherwise the lamp may not be turned on.

- (4) The inverter uses high voltage. Therefore, power should be disconnected before the inverter is assembled or disassembled.
- (5) The output of the inverter must have symmetrical(negative and positive) voltage waveform and current waveform.

Please do not use the inverter which has unsymmetrical voltage and current and spike wave. Designing a system inverter intended to have better display performance, power efficiency and lamp reliability, please follow the requirements the below. They would help increase the lamp lifetime and reduce leakage current.

- The asymmetry rate of the inverter waveform should be less than 10%.
 - The distortion rate of the waveform should be within $2 \pm 10\%$.
- * Inverter output waveform had better be more similar to ideal sine wave.

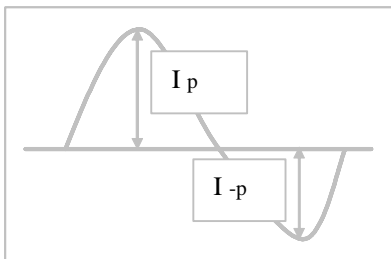

* Asymmetry rate:

$$|I_p - I_{-p}| / I_{rms} \times 100\%$$

* Distortion rate

$$I_p \text{ (or } I_{-p}) / I_{rms}$$

4. Block Diagram

4.1 TFT LCD MODULE

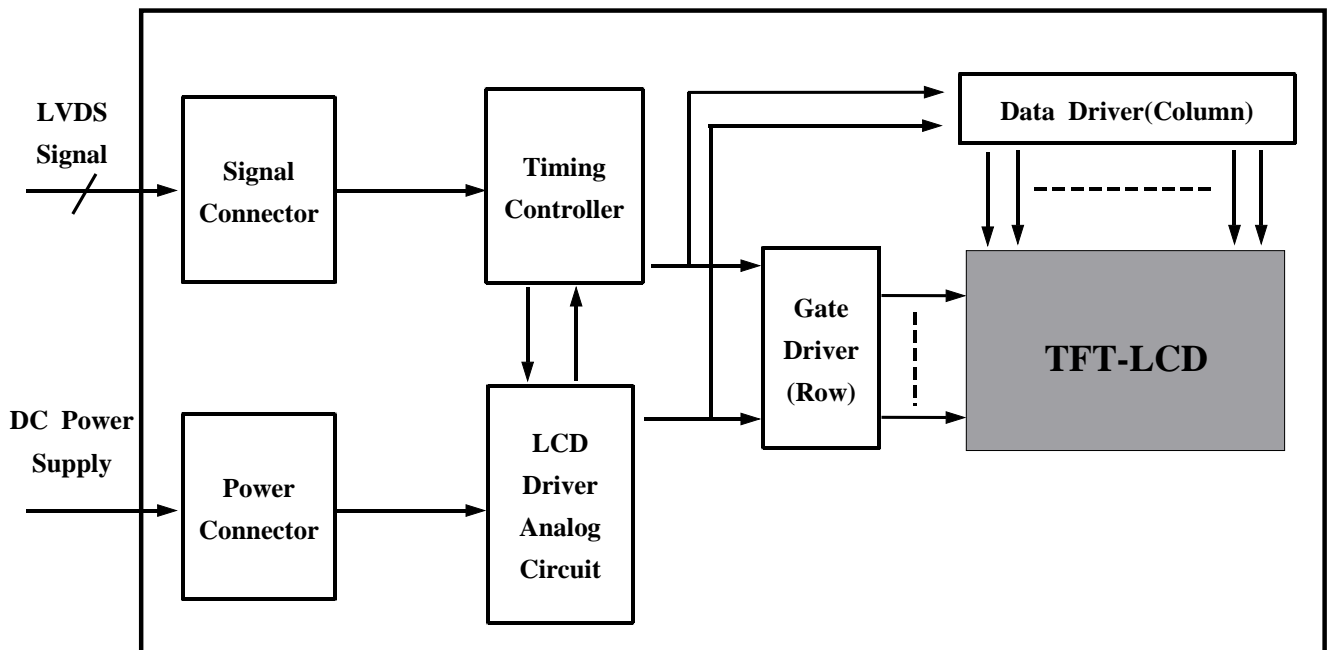

4.2 BACK-LIGHT UNIT

Connector : YEONHO 20015HS-04L or equivalent

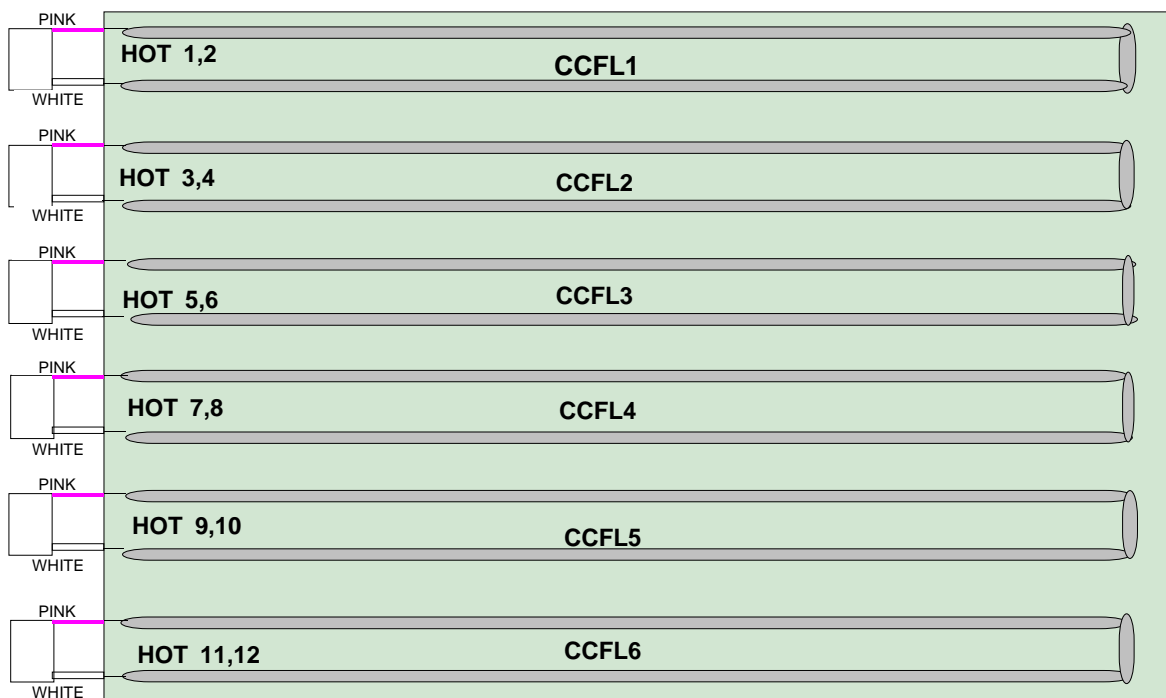

5. Input Terminal Pin Assignment

5.1. Input Signal (Connector : JAE FI-XB30SSL-HF15 or equivalent)

Pin No	Symbol	Function
1	RXO0N	Negative LVDS differential data output
2	RXO0P	Positive LVDS differential data output
3	RXO1N	Negative LVDS differential data output
4	RXO1P	Positive LVDS differential data output
5	RXO2N	Negative LVDS differential data output
6	RXO2P	Positive LVDS differential data output
7	GND	Ground
8	RXOCN	Negative LVDS differential Clock output
9	RXOCP	Positive LVDS differential Clock output
10	RXO3N	Negative LVDS differential data output
11	RXO3P	Positive LVDS differential data output
12	RXE0N	Negative LVDS differential data output
13	RXE0P	Positive LVDS differential data output
14	GND	Ground
15	RXE1N	Negative LVDS differential data output
16	RXE1P	Positive LVDS differential data output
17	GND	Ground
18	RXE2N	Negative LVDS differential data output
19	RXE2P	Positive LVDS differential data output
20	NC	No Connection
21	NC	No Connection
22	RXE3N	Negative LVDS differential data output
23	RXE3P	Positive LVDS differential data output
24	GND	Ground
25	NC	* CE (For LCD internal use only. Do not connect)
26	NC	* CTL (For LCD internal use only. Do not connect)
27	NC	No Connection
28	NC	No Connection
29	NC	No Connection
30	NC	No Connection

Note) * If the system already uses the 25, 26pins, it should keep under GND level.
The voltage applied to those pins should not exceed -200mV.

5.2 LDI Interface

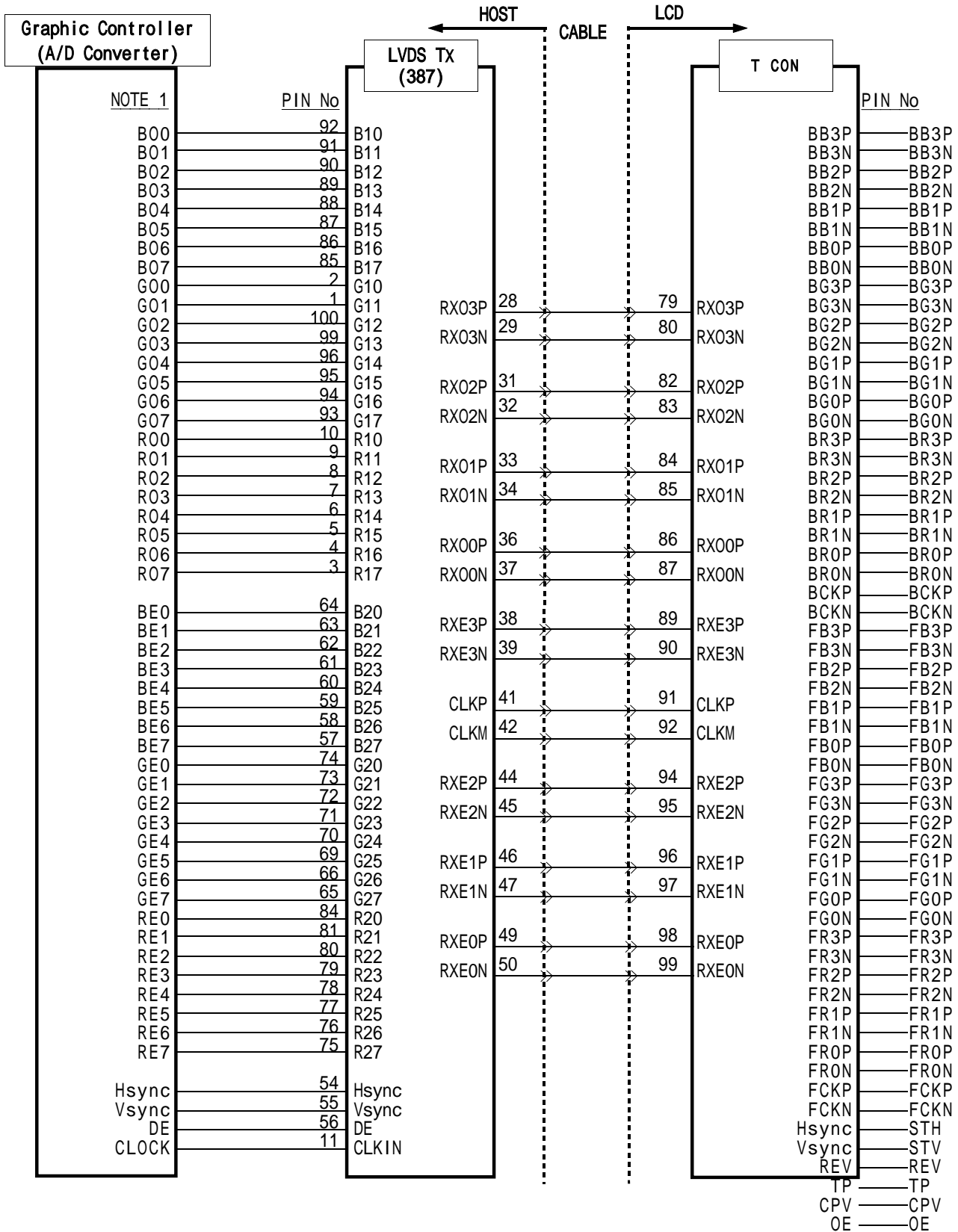

NOTE 1 : SIGNAL CONFIGURATION[Graphic Controller(A/D Converter) Output]

ODD DATA(ROx, BOx, GOx : 1'st, 3'rd, 5'th data)

EVEN DATA(REx, GEx, BEx : 2'nd, 4'th, 6'th data)

NOTE 2 : Use FI-XB30SSL-HF15 JAE Connector on the TFT module side

Use Twisted Differential Cable(Impedence:50)

5.3 Input Power (Connector : YEONHO 12507WR-12L or equivalent)

Pin No	Symbol	Function
1	Vin(+5V)	Module Input Power
2		
3		
4		
5		
6		
7	GND	Ground
8		
9		
10		
11		
12		

5.4 Back-light Unit

Pin No	Input [ch1],[ch2]	Color	Function
1-1	HOT	Pink	High Voltage
1-2	HOT	White	High Voltage
2-3	HOT	Pink	High Voltage
2-4	HOT	White	High Voltage
3-5	HOT	Pink	High Voltage
3-6	HOT	White	High Voltage
4-7	HOT	Pink	High Voltage
4-8	HOT	White	High Voltage
5-9	HOT	Pink	High Voltage
5-10	HOT	White	High Voltage
6-11	HOT	Pink	High Voltage
6-12	HOT	White	High Voltage
Connector Part No	YEONHO 20015HS-04L or equivalent		

5.5 Input Signals, Basic Display Colors and Gray Scale of Each Color

COLOR	DISPLAY	DATA SIGNAL																												GRAY SCALE LEVEL
		RED								GREEN								BLUE												
		R0	R1	R2	R3	R4	R5	R6	R7	G0	G1	G2	G3	G4	G5	G6	G7	B0	B1	B2	B3	B4	B5	B6	B7					
BASIC COLOR	BLACK	0	0	0	0	0	0	0	0	0	0	0	0	0	0	0	0	0	0	0	0	0	0	0	0	0	0	-		
	BLUE	0	0	0	0	0	0	0	0	0	0	0	0	0	0	0	0	1	1	1	1	1	1	1	1	1	1	-		
	GREEN	0	0	0	0	0	0	0	0	1	1	1	1	1	1	1	1	0	0	0	0	0	0	0	0	0	0	-		
	CYAN	0	0	0	0	0	0	0	0	1	1	1	1	1	1	1	1	1	1	1	1	1	1	1	1	1	1	-		
	RED	1	1	1	1	1	1	1	1	0	0	0	0	0	0	0	0	0	0	0	0	0	0	0	0	0	0	-		
	MAGENTA	1	1	1	1	1	1	1	1	0	0	0	0	0	0	0	0	1	1	1	1	1	1	1	1	1	1	-		
	YELLOW	1	1	1	1	1	1	1	1	1	1	1	1	1	1	1	1	0	0	0	0	0	0	0	0	0	0	-		
	WHITE	1	1	1	1	1	1	1	1	1	1	1	1	1	1	1	1	1	1	1	1	1	1	1	1	1	1	-		
GRAY SCALE OF RED	BLACK	0	0	0	0	0	0	0	0	0	0	0	0	0	0	0	0	0	0	0	0	0	0	0	0	0	0	R0		
	DARK	1	0	0	0	0	0	0	0	0	0	0	0	0	0	0	0	0	0	0	0	0	0	0	0	0	0	R1		
		0	1	0	0	0	0	0	0	0	0	0	0	0	0	0	0	0	0	0	0	0	0	0	0	0	0	R2		
		:	:	:	:	:	:	:	:	:	:	:	:	:	:	:	:	:	:	:	:	:	:	:	:	:	:	R3~ R252		
		:	:	:	:	:	:	:	:	:	:	:	:	:	:	:	:	:	:	:	:	:	:	:	:	:	:			
	LIGHT	1	0	1	1	1	1	1	1	0	0	0	0	0	0	0	0	0	0	0	0	0	0	0	0	0	0	R253		
		0	1	1	1	1	1	1	1	0	0	0	0	0	0	0	0	0	0	0	0	0	0	0	0	0	0	R254		
	RED	1	1	1	1	1	1	1	1	0	0	0	0	0	0	0	0	0	0	0	0	0	0	0	0	0	0	R255		
GRAY SCALE OF GREEN	BLACK	0	0	0	0	0	0	0	0	0	0	0	0	0	0	0	0	0	0	0	0	0	0	0	0	0	0	G0		
	DARK	0	0	0	0	0	0	0	0	1	0	0	0	0	0	0	0	0	0	0	0	0	0	0	0	0	0	G1		
		0	0	0	0	0	0	0	0	0	1	0	0	0	0	0	0	0	0	0	0	0	0	0	0	0	0	G2		
		:	:	:	:	:	:	:	:	:	:	:	:	:	:	:	:	:	:	:	:	:	:	:	:	:	:	G3~ G252		
		:	:	:	:	:	:	:	:	:	:	:	:	:	:	:	:	:	:	:	:	:	:	:	:	:	:			
	LIGHT	0	0	0	0	0	0	0	0	1	0	1	1	1	1	1	1	0	0	0	0	0	0	0	0	0	0	G253		
		0	0	0	0	0	0	0	0	0	1	1	1	1	1	1	1	0	0	0	0	0	0	0	0	0	0	G254		
	GREEN	0	0	0	0	0	0	0	0	1	1	1	1	1	1	1	1	0	0	0	0	0	0	0	0	0	0	G255		
GRAY SCALE OF BLUE	BLACK	0	0	0	0	0	0	0	0	0	0	0	0	0	0	0	0	0	0	0	0	0	0	0	0	0	0	B0		
	DARK	0	0	0	0	0	0	0	0	0	0	0	0	0	0	0	0	1	0	0	0	0	0	0	0	0	0	B1		
		0	0	0	0	0	0	0	0	0	0	0	0	0	0	0	0	0	1	0	0	0	0	0	0	0	0	B2		
		:	:	:	:	:	:	:	:	:	:	:	:	:	:	:	:	:	:	:	:	:	:	:	:	:	:	B3~ B252		
		:	:	:	:	:	:	:	:	:	:	:	:	:	:	:	:	:	:	:	:	:	:	:	:	:	:			
	LIGHT	0	0	0	0	0	0	0	0	0	0	0	0	0	0	0	0	1	0	1	1	1	1	1	1	1	1	B253		
		0	0	0	0	0	0	0	0	0	0	0	0	0	0	0	0	0	1	1	1	1	1	1	1	1	1	B254		
	BLUE	0	0	0	0	0	0	0	0	0	0	0	0	0	0	0	0	1	1	1	1	1	1	1	1	1	1	B255		

Note) Definition of Gray :

Rn : Red Gray, Gn : Green Gray, Bn : Blue Gray (n = Gray level)

Input Signal : 0 = Low level voltage, 1 = High level voltage

6. Interface Timing

6.1 Timing Parameters (DE only mode)

Signal	Item	Symbol	Min.	Typ.	Max.	Unit	Note
Clock	Frequency	1/Tc	71.0	77.0	83.0	MHz	(1),(2)
	High Time	T _{CH}	3.5	-	-	nsec	
	Low Time	T _{CL}	4.5	-	-	nsec	
Data	Setup Time	T _{DS}	2.4	-	-	nsec	
	Hold Time	T _{DH}	3.4	-	-	nsec	
Data Enable	Setup Time	T _{ES}	4.0	-	-	nsec	
Frame Frequency	Cycle	T _V	-	16.7	-	msec	
			1209	1235	1245	lines	
Vertical Active Display Term	Display Period	T _{VD}	1200	1200	1200	lines	
	Vertical Blank Period	T _{VB}	9	35	45	lines	
One Line Scanning Time	Cycle	T _H	1030	1040	1075	clocks	2pixel/clock (3)
Horizontal Active Display Term	Display Period	T _{HD}	960	960	960	clocks	
			1920	1920	1920	pixel	

Note 1) Test Point : TTL control signal and CLK at LVDS Tx input terminal in system

2) Internal V_{cc} = 3.3V

3) When operating, the DE signal should have the same period.

6.2 Timing diagrams of interface signal (DE only mode)

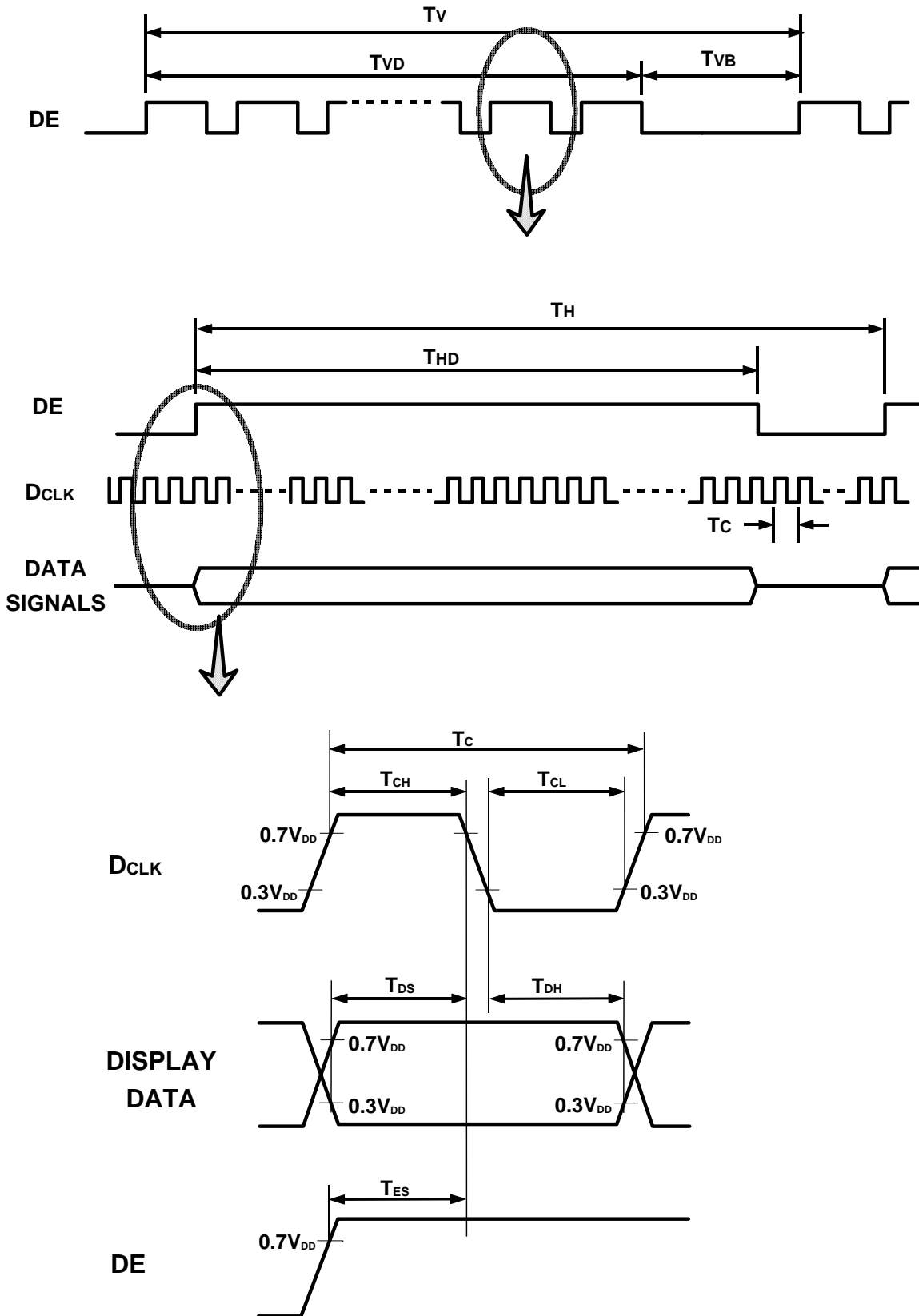

6.3 Power ON/OFF Sequence

: To prevent a latch-up or DC operation of the LCD module, the power on/off sequence should be as the diagram below.

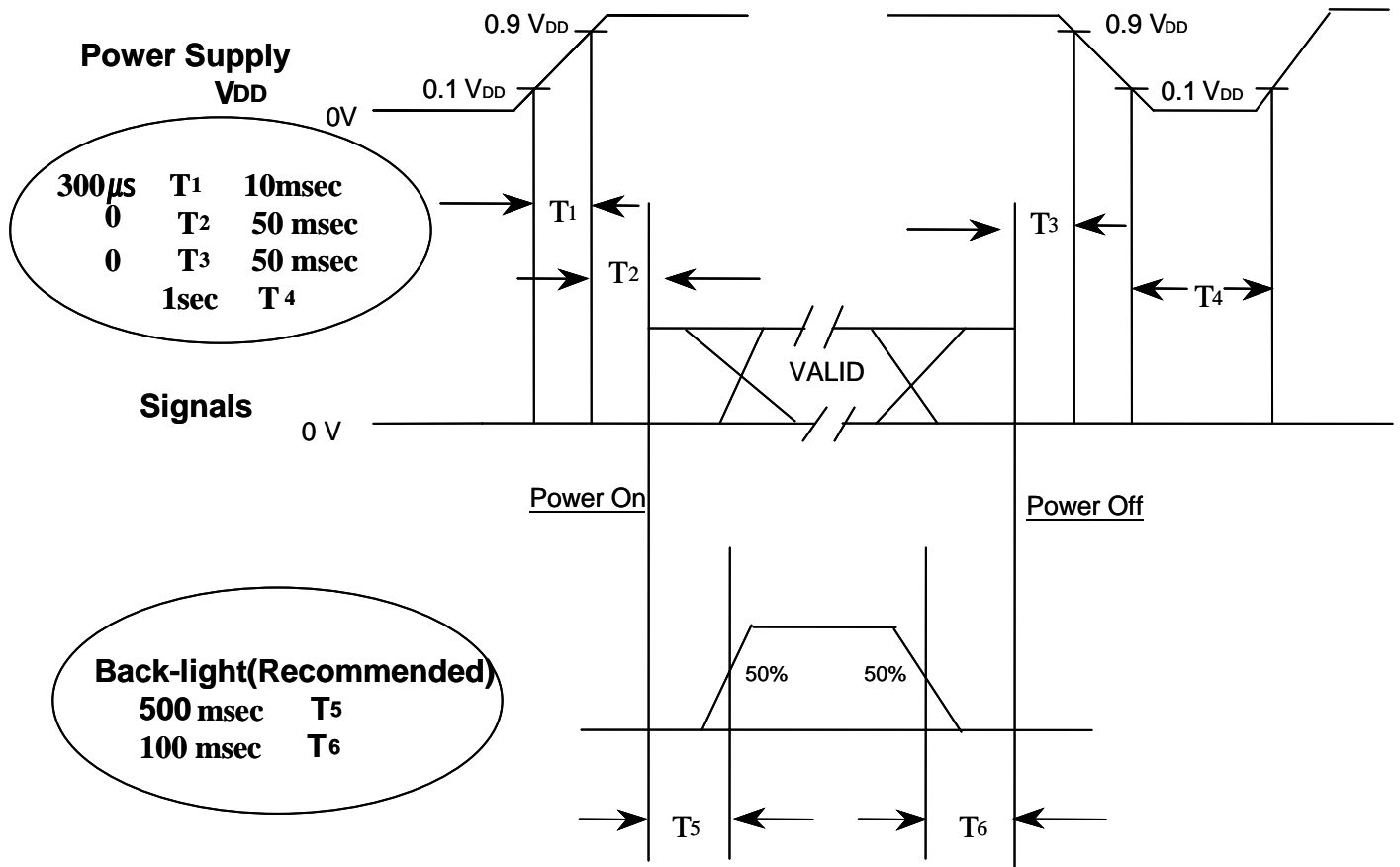

Power ON/OFF Sequence

NOTE.

- (1) The supply voltage of the external system for the module input should be the same as the definition of V_{DD}.
- (2) Apply the lamp voltage within the LCD operation range. When the back-light turns on before the LCD operation or the LCD turns off before the back-light turns off, the display may momentarily become abnormal screen.
- (3) In case of V_{DD} = off level, please keep the level of input signals low or keep a high impedance.
- (4) T4 should be measured after the module has been fully discharged between power off and on period.
- (5) Interface signal should not be kept at high impedance when the power is on.

6.4 V_{DD} Power Dip Condition

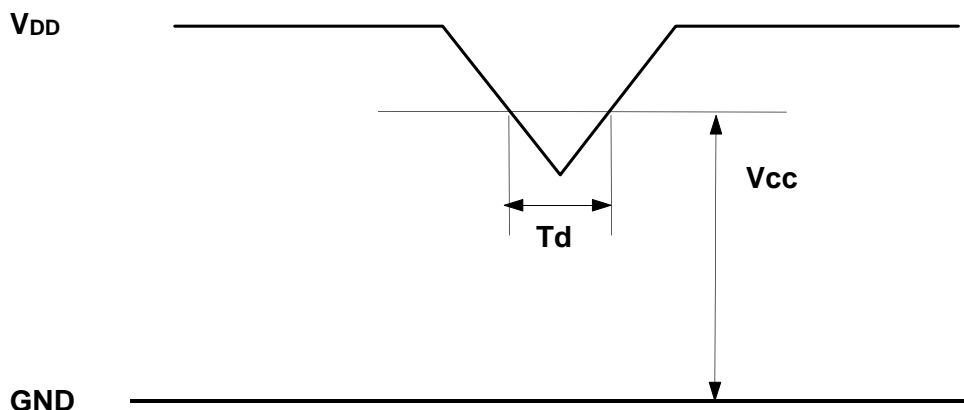

4.5V	V _{DD}	5.5V
if V _{DD} (typ) x 20%	V _{CC}	V _{DD} (typ) x 10%,
then, 0 < T _d	20msec	

NOTE

- (1) The above conditions are for the glitch of the input voltage.
- (2) For stable operation of an LCD module power, please follow them.
i.e., if typ V_{DD} x 20% V_{CC} typ V_{DD} x 10%,
then T_d should be less than 20ms.

6.5 LVDS Input Characteristics

6.5.1 LVDS Receiver input

Symbol	Parameter	Conditions	Min	Typ	Max	unit	Note
V_{TH}	LVDS input high threshold	$V_{CMLVDS} = 1.25V$			+100	mV	
V_{TL}	LVDS input low threshold		-100			mV	
V_{CMLVDS}	LVDS input common mode voltage		1.125	1.25	1.375	V	
I_{IN}	Input current	$V_{IN}=2.4V/0V$ $V_{DD}=3.6V$	-10		+10	μA	
t_{skew}	skew between LVDS clock & LVDS data		-200	0	200	psec	(1)

Note (1) LVDS skew

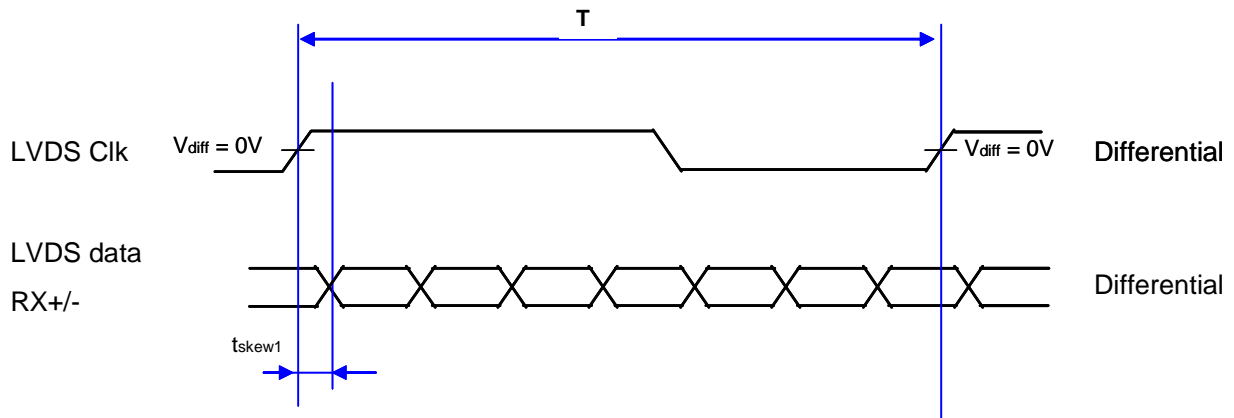

where t_{skew} : skew between LVDS clock & LVDS data,

T : 1 period time of LVDS clock

cf) (-/+) of 200psec means LVDS data goes before or after LVDS clock.

6.5.2 RSDS Output

Symbol	Parameter	Conditions	Min	Typ	Max	unit
V_{OH}DIF	Output differential high voltage	$R_L = 100$ $P_{II} = 13K$	150	170	200	mV
V_{OL}DIF	Output differential low voltage		-200	170	150	mV
V_{CM}	RSDS output common voltage		1.0	1.2	1.4	V
R_L	RSDS output load impedance		50	100	110	

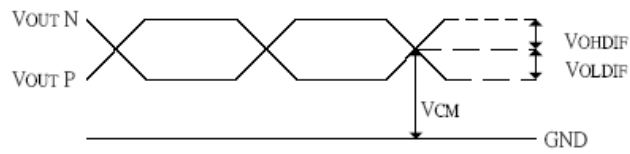

7. Outline Dimension

(Refer to next page)

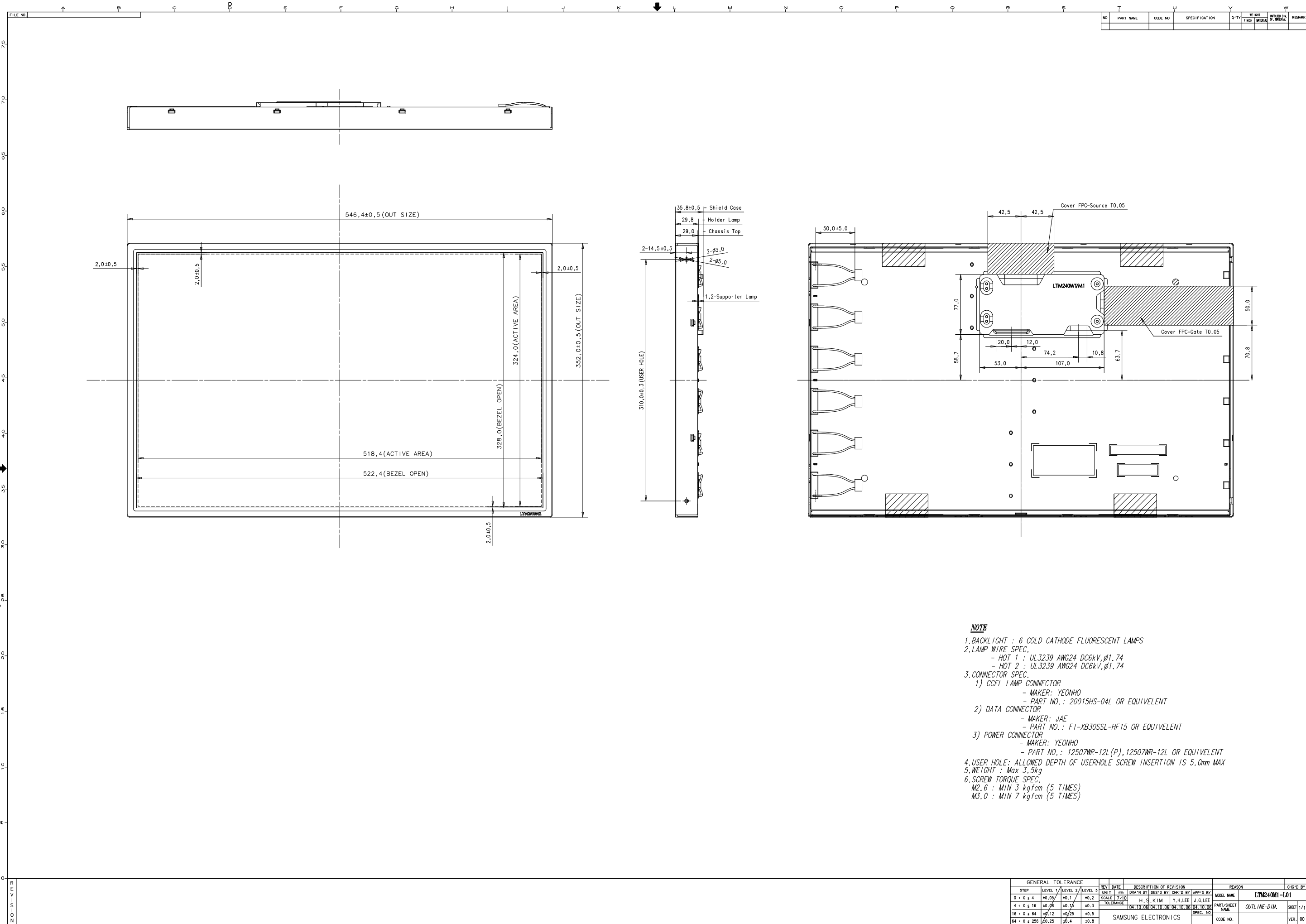

NOTE

- BACKLIGHT : 6 COLD CATHODE FLUORESCENT LAMPS
- LAMP WIRE SPEC.
 - HOT 1 : UL3239 AWG24 DC6kV, φ1.74
 - HOT 2 : UL3239 AWG24 DC6kV, φ1.74
- CONNECTOR SPEC.
 - CCFL LAMP CONNECTOR
 - MAKER: YEONHO
 - PART NO. : 20015HS-04L OR EQUIVELENT
 - DATA CONNECTOR
 - MAKER: JAE
 - PART NO. : F1-XB30SSL-HF15 OR EQUIVELENT
 - POWER CONNECTOR
 - MAKER: YEONHO
 - PART NO. : 12507WR-12L(P), 12507WR-12L OR EQUIVELENT
- USER HOLE: ALLOWED DEPTH OF USERHOLE SCREW INSERTION IS 5.0mm MAX
- WEIGHT : Max 3.5kg
- SCREW TORQUE SPEC.
 - M2.6 : MIN 3 kgfcm (5 TIMES)
 - M3.0 : MIN 7 kgfcm (5 TIMES)

GENERAL TOLERANCE				REV. DATE	DESCRIPTION OF REVISION	REASON	CHK'D BY
STEP	LEVEL 1	LEVEL 2	LEVEL 3	NO.	DATE	BY	DATE
0 < X < 4	±0.05	±0.1	±0.2				
4 < X < 16	±0.08	±0.15	±0.3				
16 < X < 64	±0.12	±0.25	±0.5				
64 < X < 256	±0.25	±0.4	±0.8				

MODEL NAME	PART/SHEET NAME	OUTLINE-DIM.	SHEET 1/1
LTM240M1-L01			

DATE	BY	CHK'D BY	REASON
04.10.04	H.S.KIM	Y.H.LEE	INITIAL

CODE NO.	VER.
	00

8. General Precautions

8.1 Handling

- (a) When the module is assembled, it should be attached to the system firmly using all mounting holes. Be careful not to twist nor bend the modules.
- (b) Because the inverter use high voltage, it should be disconnected from power before it is assembled or disassembled.
- (c) Refrain from strong mechanical shock and /or any force to the module.
In addition to damage, this may cause improper operation or damage to the module and CCFT back-light.
- (d) Note that polarizers are very fragile and could be easily damaged.
Do not press or scratch the surface using the harder than a HB pencil lead.
- (e) Wipe off water droplets or oil immediately.
If you leave the droplets for a long time, staining and discoloration may occur.
- (f) If the surface of the polarizer is dirty, clean it using some absorbent cotton or soft cloth.
- (g) The desirable cleaners are water, IPA(Isopropyl Alcohol) or Hexane.
Do not use Ketone type materials(ex. Acetone), Ethyl alcohol, Toluene, Ethyl acid or Methyl chloride. It might permanent damage to the polarizer due to chemical reaction.
- (h) If the liquid crystal material leaks from the panel, it should be kept away from the eyes or mouth. In case of contact with hands, legs or clothes, it must be washed away thoroughly with soap.
- (i) Protect the module from static which may cause damage to the CMOS Gate Array IC.
- (j) Use finger-stalls with soft gloves in order to keep display clean during the incoming inspection and assembly process.
- (k) Do not disassemble the module.
- (l) Do not pull or fold the lamp wire.
- (m) Do not adjust the variable resistor located on the module.
- (n) Protection film for polarizer on the module should be slowly peeled off just before use so that the electrostatic charge can be minimized.
- (o) Pins of I/F connector should not be touched directly with bare hands.

8.2 Storage

- (a) Do not leave the module in high temperature, high humidity for a long time. It is highly recommended to store the module with temperature from 0 to 35 and relative humidity of less than 70%.
- (b) Do not store the TFT-LCD module in direct sunlight.
- (c) The module should be stored in a dark place. It is prohibited to apply sunlight or fluorescent light in storage.

8.3 Operation

- (a) Do not connect or disconnect the module in the "Power On" condition.
- (b) Power supply should always be turned on/off by 6.3 "Power on/off sequence"
- (c) Module has high frequency circuits. Sufficient suppression to the electromagnetic interference should be done by system manufacturers. Grounding and shielding methods may be important to minimize the interference.
- (d) The cable between the back-light connector and its inverter power supply should be connected directly with a minimized length. A longer cable between the back-light and the inverter may cause lower luminance of lamp(CCFT) and may require higher startup voltage(Vs).

8.4 Others

- (a) Ultra-violet ray filter is necessary for outdoor operation.
- (b) Avoid condensation of water which may result in improper operation or disconnection of electrode.
- (c) Do not exceed the absolute maximum rating value. (supply voltage variation, input voltage variation, variation in part contents and environmental temperature, and so on)
Otherwise the module may be damaged.
- (d) If the module keeps displaying the same pattern for a long period of time, the image may "stick" to the screen.
To avoid image sticking, it is recommended to use a screen saver.
- (e) This module has its circuitry PCB's on the rear side and should be handled carefully in order not to be stressed.
- (f) Please contact SEC in advance when you display the same pattern for a long time.