



ELECTRONICS

Approval Specification

Customer :

DATE : 2005-11-08



SAMSUNG TFT-LCD

MODEL : LTM201U1-L01

Any Modification of Specification is not allowed without SEC's Permission.

Specifically for Guangzhou Fukoor Technology Ltd.

Customer's Approval	
SIGNATURE	DATE 2005-11-08

PREPARED BY 	DATE 2005-11-08
APPROVAED BY 	DATE 2005-11-08

LCD Application Engineering 2, TCS Team

Samsung Electronics Co . , LTD.



SAMSUNG TFT-LCD

MODEL	LTM201U1 -L01	Doc. No	05 -E00 -G -051108	Page	1/40
-------	---------------	---------	--------------------	------	------

Contents

Revision History	-----	(3)
General Description	-----	(4)
1. Absolute Maximum Ratings	-----	(5)
2. Optical Characteristics	-----	(7)
3. Electrical Characteristics	-----	(13)
3.1 TFT LCD Module		
3.2 Back Light Unit		
4. Block Diagram	-----	(18)
4.1 TFT LCD Module		
4.2 Back Light Unit		
5. Input Terminal Pin Assignment	-----	(19)
5.1 Input Signal & Power		
5.2 LVDS Interface		
5.3 LVDS Interface(2)		
5.4 Back Light Unit		
5.5 Input Signals, Basic Display Colors and Gray Scale of Each Color		
6. Interface Timing	-----	(28)
6.1 Timing Parameters (DE only mode)		
6.2 Timing Diagrams of interface Signal (DE only mode)		
6.3 Power ON/OFF Sequence		
6.4 LVDS Input Characteristics		
6.5 VDD Power Dip Condition		
7. Outline Dimension	-----	(32)
8. Reliability Test	-----	(34)
9. Packing	-----	(35)
10. Marking & Others	-----	(36)
11. General Precaution	-----	(38)
11.1 Handling		
11.2 Storage		
11.3 Operation		
11.4 Others		

*** Revision History**

Approval Specification

Date	Rev. No	Page	Summary
Nov. 08, 2005	E00	all	Standard specification of All model was issued first.

MODEL

LTM201U1 -L01

Doc. No

05-E00-G-051108

Page

3/40

General Description

Description

LTM201U1-L01 is a color active matrix TFT (Thin Film Transistor) liquid crystal display(LCD) that uses amorphous silicon TFTs as switching devices. This model is composed of a TFT LCD panel, a driver circuit and a back-light system. The resolution of a 20.1" contains 1600 x 1200 pixels and can display up to 16.7 million colors with wide viewing angle of 89° or higher in all directions. (Vertical viewing angle : 178° , Horizontal viewing angle : 178°)

Features

- High contrast ratio, high aperture structure
- SPVA(Super Patterned Vertical Alignment) Mode
- Wide viewing angle (± 178 °)
- High speed response
- UXGA (1600 x1200) resolution
- Replaceable 2 triple CCFTs (Cold Cathode Fluorescent Tube)
- Low Power consumption
- DE only mode
- Narrow bezel and compact design
- Pb-free configuration
- RoHS compliance

Applications

- Workstation & desktop monitors
 - Display terminals for AV application products
 - Monitors for industrial and medical application products
- * If the module is used to other applications besides the above, please contact SEC in advance.

General Information

Items	Specification	Unit	Note
Pixel Pitch	0.255(H) x 0.255(W)	mm	
Active Display Area	408(H) x 306(V)	mm	
Surface Treatment	Haze 44% , Hard-coating (3H)		
Display Colors	16.7M (true 8-bit)	colors	
Number of Pixels	1600 x 1200	pixel	
Pixel Arrangement	RGB vertical stripe		
Display Mode	Normally Black		
Luminance of White	300(Typ.)	cd/m ²	

MODEL

LTM201U1 -L01

Doc. No

05 -E00 -G -051108

Page

4/40

Mechanical Information

Item		Min.	Typ.	Max.	Unit	Note
Module size	Horizontal (H)	431.5	432.0	432.5	mm	w/o inverter ass'y
	Vertical (V)	331.0	331.5	332.0	mm	
	Depth (D)			25.5	mm	
Weight				3,300	g	LCD module only
					g	w/ Inverter assembly

Note (1) Mechanical tolerance is $\pm 0.5\text{mm}$ unless there is a special comment.

1. Absolute Maximum Ratings

If the condition exceeds maximum ratings, it can cause malfunction or unrecoverable damage to the device.

Item	Symbol	Min.	Max.	Unit	Note
Power Supply Voltage	V_{DD}	GND-0.5	6.5	V	(1)
Storage temperature	T_{STG}	-25	60		(2)
Glass surface temperature (Operation temperature)	T_{OPR}	0	50		(5)
Shock (non - operating)	S_{nop}	-	50	G	(3)
Vibration (non - operating)	V_{nop}	-	1.5	G	(4)

Note (1) $T_a = 25 \pm 2 \text{ }^\circ\text{C}$

- (2) Temperature and relative humidity range are shown in the figure below.
 - a. 90 % RH Max. ($T_a \leq 39^\circ\text{C}$)
 - b. Maximum wet-bulb temperature at 39°C or less. ($T_a \leq 39^\circ\text{C}$)
 - c. No condensation
- (3) 11ms, sine wave, one time for $\pm X, \pm Y, \pm Z$ axis
- (4) 10-300 Hz, Sweep rate 10min, 30min for X,Y,Z axis

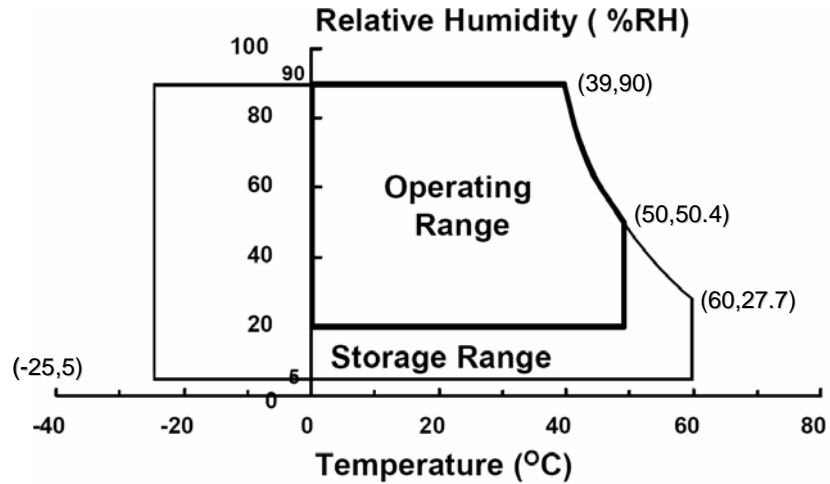
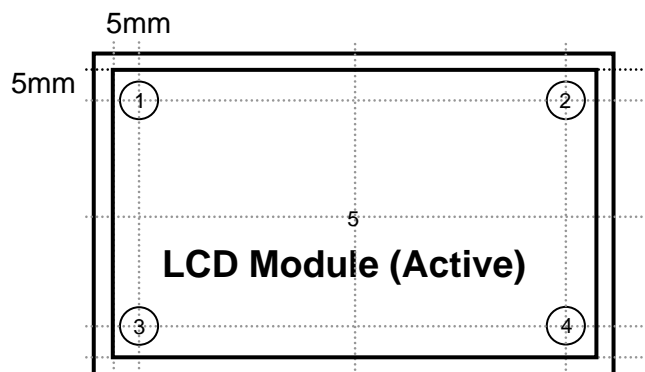

Fig. Temperature and Relative humidity range

- (5) Definition of test point



T_{OPR} : Temperature of the glass surface (Test point T1~ T5)

2. Optical Characteristics

Approval Specification

The optical characteristics should be measured in a dark room or equivalent.

Measuring equipment : TOPCON BM-7,SPECTRORADIOMETER SR-3

(Ta = 25 ± 2°C, VDD=5V, fv= 60Hz, fDCLK=65.125MHz, IL = 7.5mArms)

Item	Symbol	Condition	Min.	Typ.	Max.	Unit	Note
Contrast Ratio (Center of screen)	C/R		600	900	-		(3) SR-3
Response Time	On/Off	Tr+Tf	-	16	20	msec	(5) BM-7
	G-To-G	T _{G-G,AVG}	-	8	-	msec	BM-7
		T _{G-G,long}	-	12	-	msec	BM-7
Luminance of White (Center of screen)	Y _L		250	300	-	cd/m ²	(6) SR-3
Color Chromaticity (CIE 1931)	Red	R _x	0.610	0.640	0.670		(7),(8) SR-3
		R _y	0.300	0.330	0.360		
	Green	G _x	0.270	0.300	0.330		
		G _y	0.570	0.600	0.630		
	Blue	B _x	0.120	0.150	0.180		
		B _y	0.030	0.060	0.090		
	White	W _x	0.283	0.313	0.343		
		W _y	0.299	0.329	0.359		
Color Chromaticity (CIE 1976)	Red	R _{u'}	-	0.451	-		
		R _{v'}	-	0.523	-		
	Green	G _{u'}	-	0.125	-		
		G _{v'}	-	0.563	-		
	Blue	B _{u'}	-	0.175	-		
		B _{v'}	-	0.158	-		
	White	W _{u'}	-	0.198	-		
		W _{v'}	-	0.468	-		
C.G.L	White	u'v'	-	-	0.02		(9)

* C.G.L : Color Grayscale Linearity

(continue to the next page)

MODEL	LTM201U1 -L01	Doc. No	05 -E00 -G -051108	Page	7/40
-------	---------------	---------	--------------------	------	------

Item	Symbol	Condition	Min.	Typ.	Max.	Unit	Note		
Color Gamut	-		-	72	-	%			
Color Temperature	-		-	6500	-	K			
Viewing Angle	Hor.	L	CR 10	80	89	-	Degrees	(8) SR-3	
		R		80	89	-			
	Ver.	U		80	89	-			
		D		80	89	-			
	Hor.	L	CR 100	-	60	-	Degrees	(8) SR-3	
		R		-	60	-			
		Ver.		U	-	60			-
				D	-	60			-
Brightness Uniformity (9 Points)	B _{uni}		-	-	25	%	(4) SR-3		

Note (1) Test Equipment Setup

The measurement should be executed in a stable, windless and dark room between 30min after lighting the back light at the given temperature for stabilization of the back light. This should be measured in the center of screen.

Single lamp current : 7.5mA

Environment condition : Ta = 25 ± 2 °C

Photo detector	Field
SR-3	1 °
BM-7	2 °

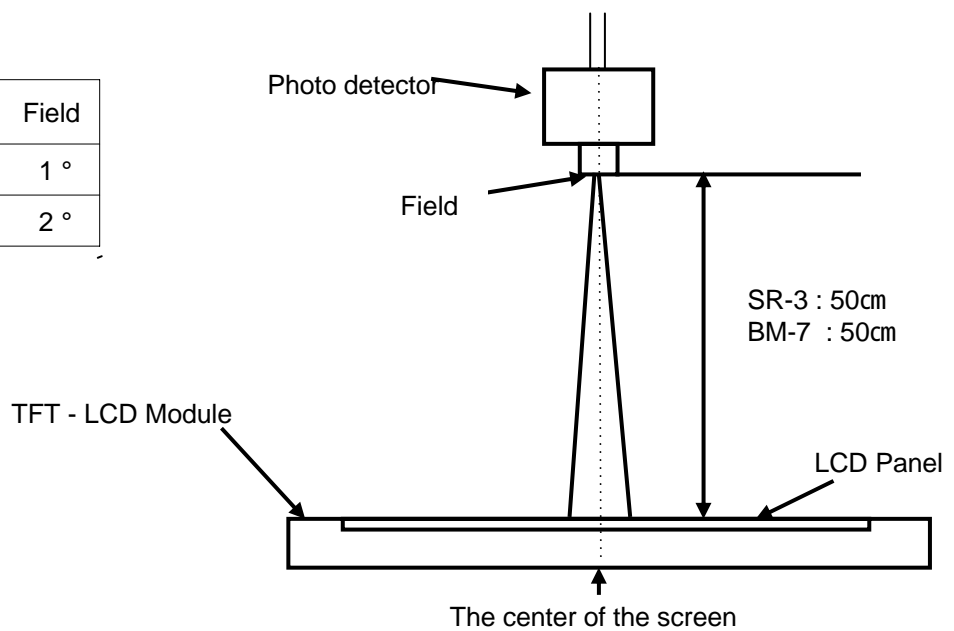

Note (2) Definition of test point

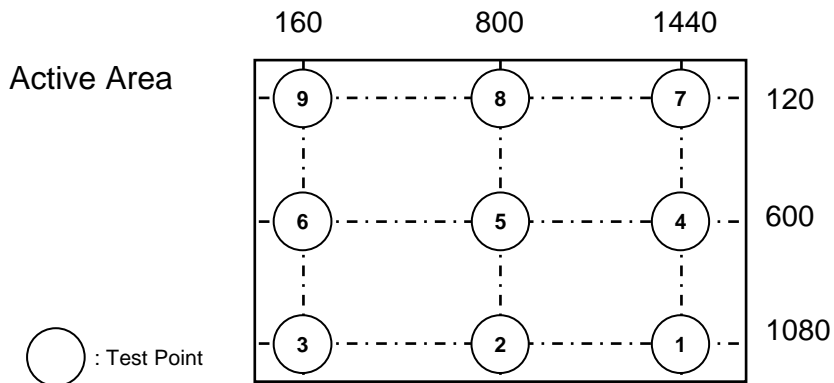

Note (3) Definition of Contrast Ratio (C/R)

: Ratio of gray max (Gmax) & gray min (Gmin) at the center point of the panel

$$CR = \frac{G \text{ max}}{G \text{ min}}$$

Gmax : Luminance with all pixels white

Gmin : Luminance with all pixels black

Note (4) Definition of 9 points brightness uniformity

$$Buni = 100 \times \frac{(B \text{ max} - B \text{ min})}{B \text{ max}}$$

Bmax : Maximum brightness

Bmin : Minimum brightness

Note (5) Definition of Response time

a. On/Off response time : Sum of T_r , T_f

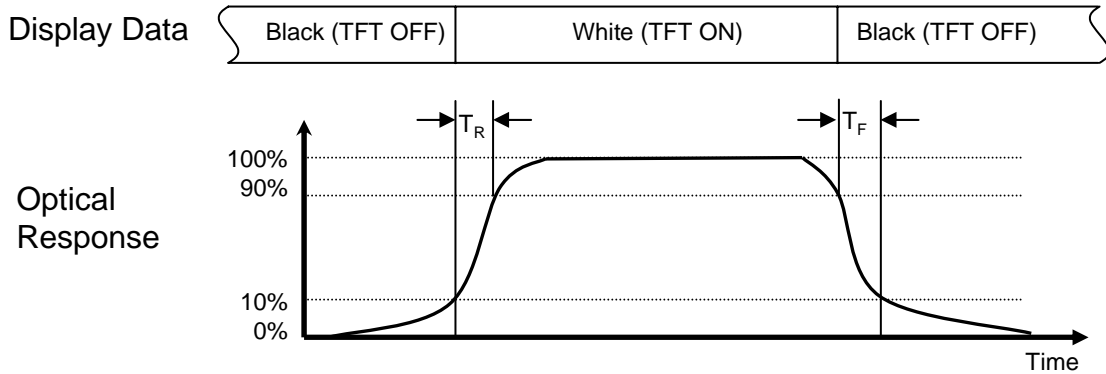

b. Gray to Gray Response Time

- Measuring gray : 31 → 63, 63 → 95, 95 → 127, 127 → 159, 159 → 191, 191 → 223
grays and vice versa

- $T_{G-G, avg}$: Average response time of ones between above grays

- $T_{G-G, long}$: The longest response time of ones between above grays

(Example)

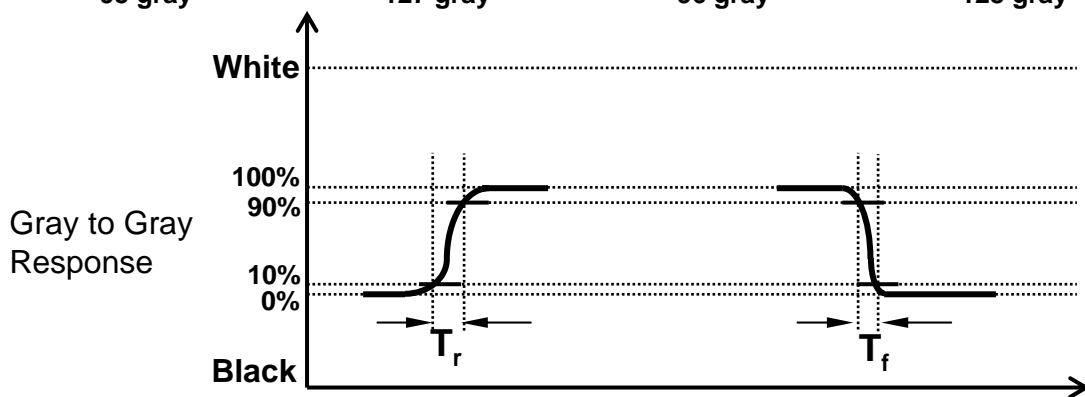

Note (9) Color Grayscale Linearity

- a. Test image : 100% full white pattern with a test pattern as below
- b. Test pattern : Squares, 40mm by 40mm in size, filled with 255, 225, 195, 165, 135 and 105 grays steps should be arranged at the center of the screen.



c. Test method

- 1st gray step : move a square of 255 gray level should be moved into the center of the screen and measure luminance and u' and v' coordinates.
- Next gray step : Move a 225 gray square into the center and measure both luminance and coordinates, too.

d. Test evaluation

$$\Delta u' v' = \sqrt{(u'_A - u'_B)^2 + (v'_A - v'_B)^2}$$

Where A, B : 2 gray levels found to have the largest color differences between them
i.e. get the largest u' and v' of each 6 pair of u' and v' and calculate the $u'v'$.

3. Electrical Characteristics

3.1 TFT LCD Module

The connector for display data & timing signal should be connected.

Ta = 25°C

Item	Symbol	Min.	Typ.	Max.	Unit	Note	
Voltage of Power Supply	V_{DD}	4.5	5.0	5.5	V	(1)	
LVDS Input Characteristics	Differential Input Voltage for LVDS Receiver Threshold	High	-	-	+100	mV	(2)
		Low	-100	-	-	mV	
	LVDS skew	t_{SKEW}	-200		200		(3)
	Differential input voltage	$ V_{ID} $	200		600	mV	(4)
	Input voltage range (single-ended)	V_{IN}	0		2.4	V	(4)
	Common mode voltage	V_{CM}	0+ $ V_{ID} /2$	1.2	2.4- $ V_{ID} /2$	V	(4)
Current of Power Supply	(a) Black	I_{DD}	-	1300	-	mA	(5),(6)
	(b) White		-	1600	-	mA	
	(c) 2-Line Vertical		-	1600	1850	mA	
Vsync Frequency	f_V	59	60	61	Hz		
Hsync Frequency	f_H	72	74	76	kHz		
Main Frequency	f_{DCLK}	64	65.125	66.25	MHz		
Rush Current	I_{RUSH}	-	-	4.0	A	(7)	

Note (1) The ripple voltage should be controlled under 10% of V_{DD} .

(2) Differential receiver voltage definitions and propagation delay and transition time test circuit

- a. All input pulses have frequency = 10MHz, t_R or $t_F=1ns$
- b. C_L includes all probe and fixture capacitance

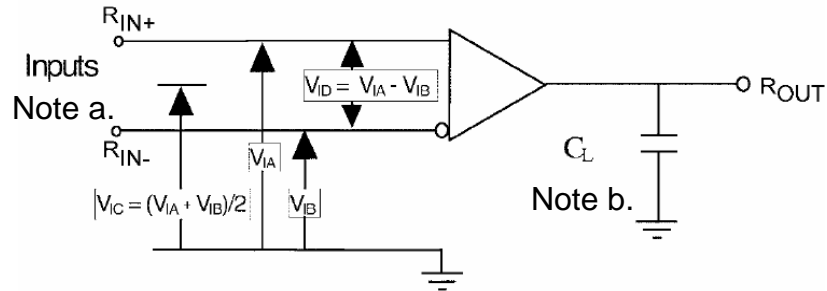

(3) LVDS Receiver DC parameters are measured under static and steady conditions which may not be reflective of its performance in the end application.

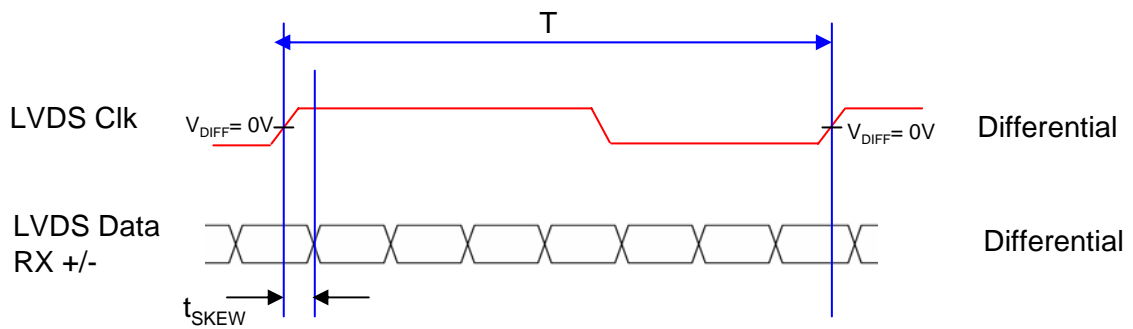

where t_{skew} : skew between LVDS clock & LVDS data,

T : 1 period time of LVDS clock

cf) (-/+) of 380psec means LVDS data goes before or after LVDS clock.

(4) Definition of V_{ID} and V_{CM} using single-end signals

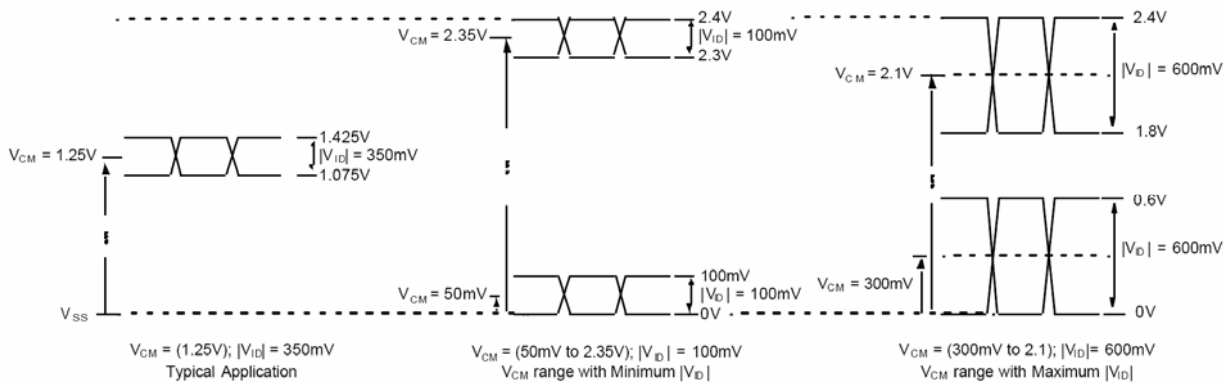

- (5) $f_V=60\text{Hz}$, $f_{\text{DCLK}} = 54\text{MHz}$, $V_{\text{DD}} = 5.0\text{V}$, DC Current.
- (6) Power dissipation check pattern (LCD Module only)

a) Black Pattern

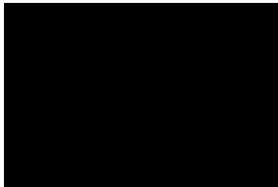

b) White Pattern



c) 2Line Vertical

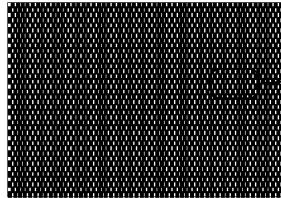

(7) Measurement Condition

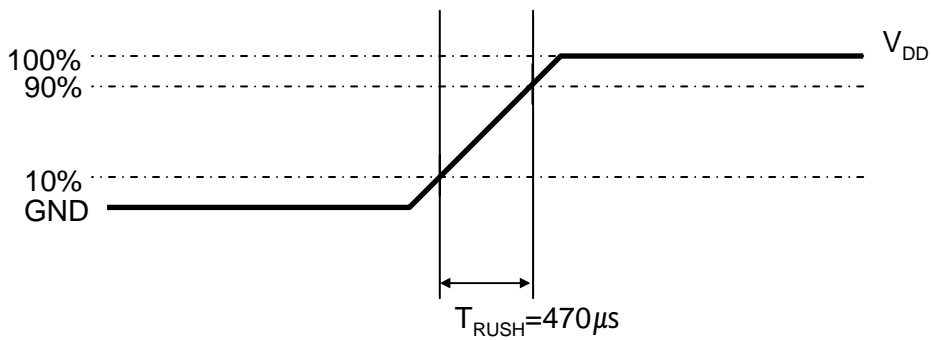

Rush Current I_{RUSH} can be measured when T_{RUSH} is $470\mu\text{s}$.

3.2 Back Light Unit

The back-light system is an edge - lighting type with 2 triple CCFTs (Cold Cathode Fluorescent Tube) The characteristics of two triple lamps are shown in the following tables.

Ta=25 ± 2°C

Item	Symbol	Min.	Typ.	Max.	Unit	Note	
Lamp Current	I_L	3.0	7.5	8.0	mArms	(1)	
Lamp Current Uniformity	I_{UNI}	-	-	25	%	(2)	
Lamp Voltage	V_L	-	700	-	Vrms		
Lamp Frequency	f_L	40	-	60	kHz	(3)	
Operating Life Time	Hr	50,000	-	-	Hour	(4)	
Inverter waveform	Asymmetry rate	Wasy	-	-	10	%	(5)
	Distortion rate	Wdis	1.2726	1.414	1.5554		
Startup Voltage	V_s	-	-	0 : 1,720	Vrms	(6)	
				25 : 1,370			

Note (1) Specified values are for a single lamp.

Lamp current is measured with current meter for high frequency as shown below.
Refer to the following block diagram of the back light unit for more information.

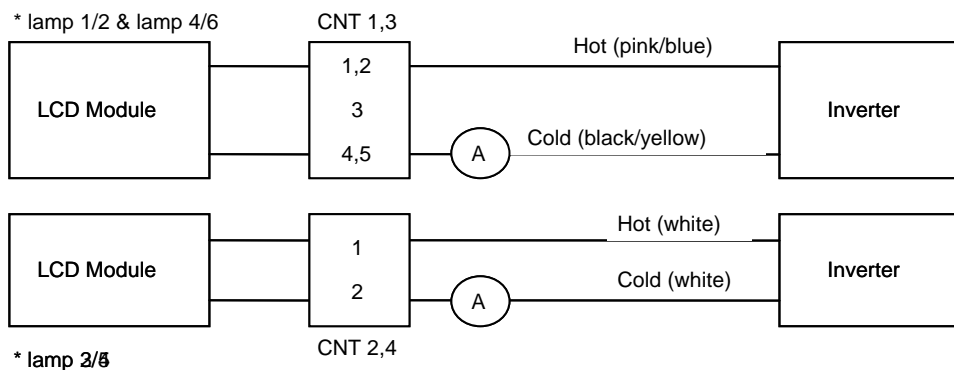

Fig. Measurement point of Lamp Current

(2) Define of Lamp current uniformity : I_{UNI}

$$I_{UNI} = \frac{|I_{Max} - I_{Min}|}{I_{Max}} \times 100$$

I_{max} : Maximum lamp current

I_{min} : Minimum lamp current

Lamp current uniformity I_{UNI} should be less than 25%

(3) Lamp frequency which may produce interference with horizontal synchronous frequency may cause line flow on the display. Therefore lamp frequency should be detached from the horizontal synchronous frequency and its harmonics as far as possible in order to avoid interference.

(4) If an inverter has shutdown function, it should keep its output for over 1 second even if the lamp connector is open. Otherwise the lamps may not be turned on.

(5) Designing a system inverter intended to have better display performance, power efficiency and lamp reliability.

They would help increase the lamp lifetime and reduce leakage current.

- The measurement should be done at typical lamp current.
- The asymmetry rate of the inverter waveform should be less than 10%.
- The distortion rate of the waveform should be 2 with $\pm 10\%$ tolerance.
 - Inverter output waveform had better be more similar to ideal sine wave.

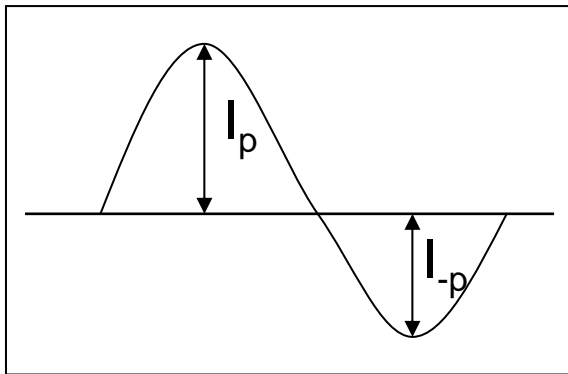

Fig. Wave form of the inverter

- Asymmetry rate

$$\frac{|I_p - I_{-p}|}{I_{rms}} \times 100$$

- Distortion rate

$$\left| \frac{I_p}{I_{rms}} \right| \text{ or } \left| \frac{I_{-p}}{I_{rms}} \right|$$

(6) If an inverter has shutdown function, it should keep its output for over 1 second even if the lamp connector is open. Otherwise the lamps may not be turned on.

4. BLOCK DIAGRAM

4.1 TFT LCD Module

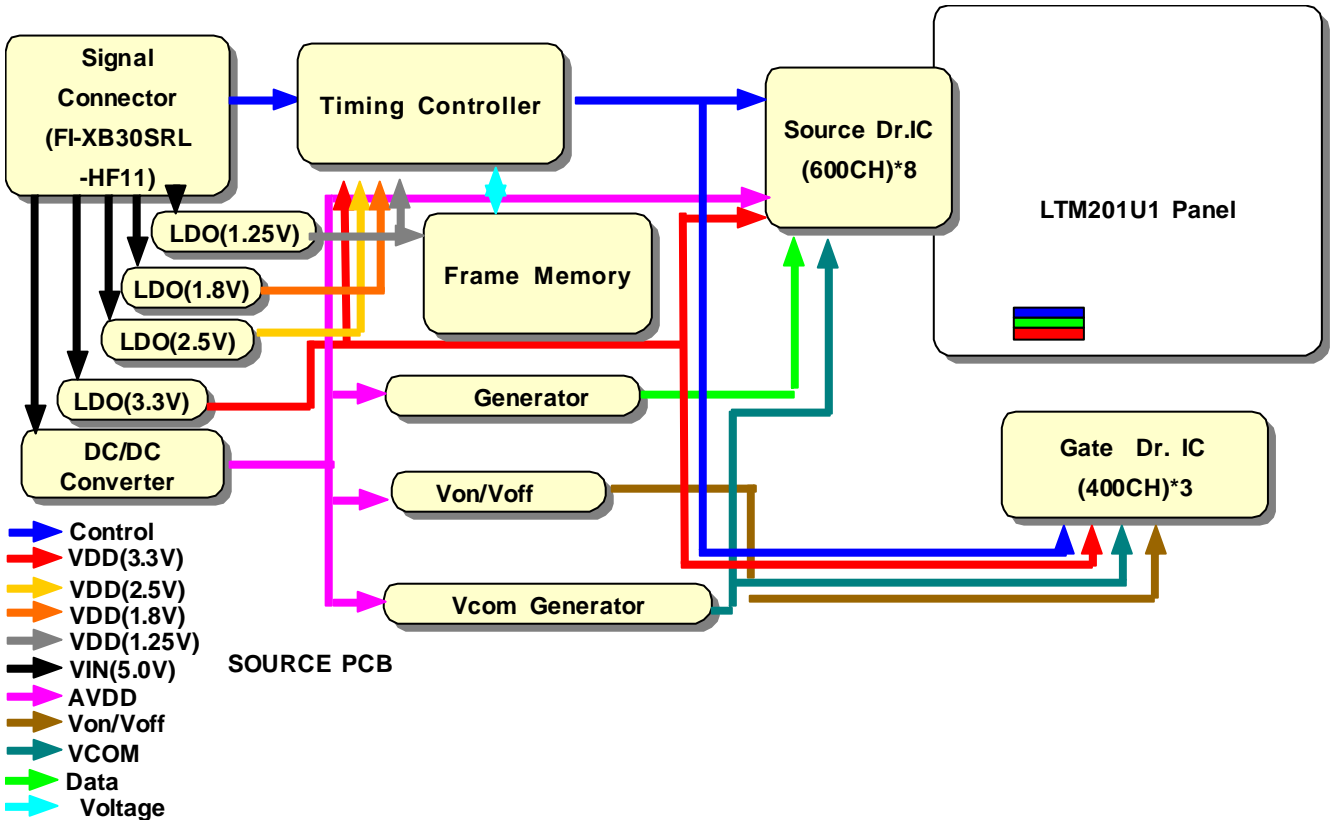

4.2 Back Light Unit

Connector :YeonHo 2pin) 35001HS-02L or equivalent Up Side
 YeonHo 5pin) 20015HS-05LB or equivalent

Up Side

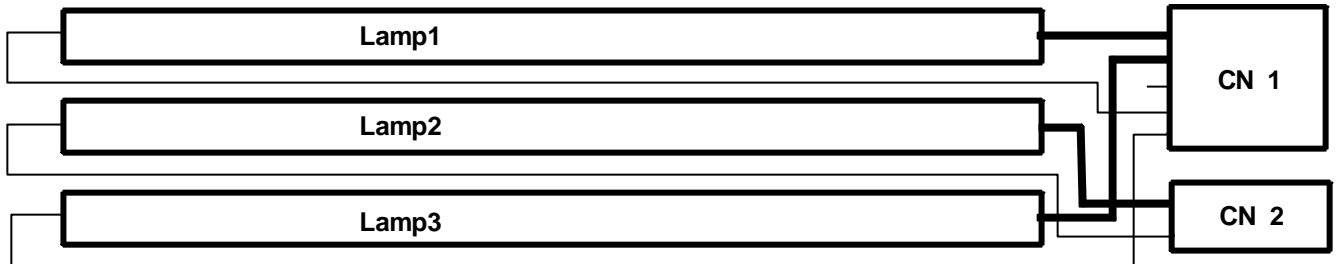

Down Side

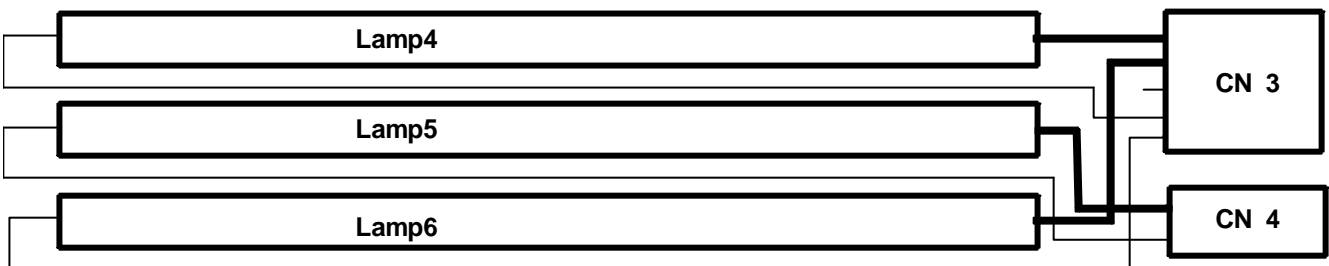

5. Input Terminal Pin Assignment

5.1. Input Signal & Power (JAE FI-XB30SRL-HF11 or equivalent)

Pin No	Symbol	Function
1	GND	Ground
2	VCC	Module Input +5V
3	VCC	Module Input +5V
4	VCC	Module Input +5V
5	VCC	Module Input +5V
6	*CE	For LCD internal use only. Do not connect
7	GND	Ground
8	RXE3+	Positive LVDS differential data output
9	RXE3-	Negative LVDS differential data output
10	RXEC+	Positive LVDS differential clock output
11	RXEC-	Negative LVDS differential clock output
12	RXE2+	Positive LVDS differential data output
13	RXE2-	Negative LVDS differential data output
14	RXE1+	Positive LVDS differential data output
15	RXE1-	Negative LVDS differential data output
16	RXE0+	Positive LVDS differential data output
17	RXE0-	Negative LVDS differential data output
18	GND	Ground
19	GND	Ground
20	RXO3+	Positive LVDS differential data output
21	RXO3-	Negative LVDS differential data output
22	RXOC+	Positive LVDS differential clock output
23	RXOC-	Negative LVDS differential clock output
24	RXO2+	Positive LVDS differential data output
25	RXO2-	Negative LVDS differential data output
26	RXO1+	Positive LVDS differential data output
27	RXO1-	Negative LVDS differential data output
28	RXO0+	Positive LVDS differential data output
29	RXO0-	Negative LVDS differential data output
30	GND	Ground
31	*CTL	For LCD internal use only. Do not connect
32	GND	Ground

* Refer to page 30 for the 1st pin of interface connector marked with .

* If the system already uses the 6, 31pins, it should keep under GND level.

The voltage applied to those pins should not exceed -200mV

Note) Pin number starts from Right side



Pin No. 30 Pin No. 1



JAE FI-XB30SRL-HF11 or equivalent

Fig. Connector diagram



- a. All GND pins should be connected together and also be connected to the LCD's metal chassis.
- b. All power input pins should be connected together.
- c. All NC pins should be separated from other signal or power.

5.2 LVDS Interface

5.2.1 Odd Pixel Data (1st pixel data)

1st LVDS Transmitter (<i>DS90C385</i>) Signal Interface						
Device Input Pin		Device Input Signal		Output Signal	To LTM201U1 Interface (CN101)	
No	Symbol	Symbol	Function		Terminal	Symbol
51	TXIN0	RO0	Red Odd Pixel Data (LSB)	TXOUT0- TXOUT0+	No. 29 No. 28	RXO0- RXO0+
52	TXIN1	RO1	Red Odd Pixel Data			
54	TXIN2	RO2	Red Odd Pixel Data			
55	TXIN3	RO3	Red Odd Pixel Data			
56	TXIN4	RO4	Red Odd Pixel Data			
2	TXIN5	RO7	Red Odd Pixel Data (MSB)	TXOUT3- TXOUT3+	No. 21 No. 20	RXO3- RXO3+
3	TXIN6	RO5	Red Odd Pixel Data	TXOUT0- TXOUT0+	No. 29 No. 28	RXO0- RXO0+
4	TXIN7	GO0	Green Odd Pixel Data (LSB)			
6	TXIN8	GO1	Green Odd Pixel Data	TXOUT1- TXOUT1+	No. 27 No. 26	RXO1- RXO1+
7	TXIN9	GO2	Green Odd Pixel Data			
8	TXIN10	GO6	Green Odd Pixel Data	TXOUT3- TXOUT3+	No. 21 No. 20	RXO3- RXO3+
10	TXIN11	GO7	Green Odd Pixel Data (MSB)			
11	TXIN12	GO3	Green Odd Pixel Data	TXOUT1- TXOUT1+	No. 27 No. 26	RXO1- RXO1+
12	TXIN13	GO4	Green Odd Pixel Data			
14	TXIN14	GO5	Green Odd Pixel Data			
15	TXIN15	BO0	Blue Odd Pixel Data (LSB)			
16	TXIN16	BO6	Blue Odd Pixel Data	TXOUT3- TXOUT3+	No. 21 No. 20	RXO3- RXO3+
18	TXIN17	BO7	Blue Odd Pixel Data (MSB)			
19	TXIN18	BO1	Blue Odd Pixel Data	TXOUT1- TXOUT1+	No. 27 No. 26	RXO1- RXO1+
20	TXIN19	BO2	Blue Odd Pixel Data	TXOUT2- TXOUT2+	No. 25 No. 24	RXO2- RXO2+
22	TXIN20	BO3	Blue Odd Pixel Data			
23	TXIN21	BO4	Blue Odd Pixel Data			
24	TXIN22	BO5	Blue Odd Pixel Data			
50	TXIN27	RO6	Red Odd Pixel Data	TXOUT3- TXOUT3+	No. 21 No. 20	RXO3- RXO3+

5.2.2 Even Pixel Data (2nd pixel data)

2nd LVDS Transmitter (DS90C385) Signal Interface						
Device Input Pin		Device Input Signal		Output Signal	To LTM201U1 Interface (CN101)	
No	Symbol	Symbol	Function		Terminal	Symbol
51	TXIN0	RE0	Red Even Pixel Data (LSB)	TXOUT0- TXOUT0+	No. 17 No. 16	RXE0- RXE0+
52	TXIN1	RE1	Red Even Pixel Data			
54	TXIN2	RE2	Red Even Pixel Data			
55	TXIN3	RE3	Red Even Pixel Data			
56	TXIN4	RE4	Red Even Pixel Data			
2	TXIN5	RE7	Red Even Pixel Data (MSB)	TXOUT3- TXOUT3+	No. 9 No. 8	RXE3- RXE3+
3	TXIN6	RE5	Red Even Pixel Data	TXOUT0- TXOUT0+	No. 17 No. 16	RXE0- RXE0+
4	TXIN7	GE0	Green Even Pixel Data (LSB)			
6	TXIN8	GE1	Green Even Pixel Data	TXOUT1- TXOUT1+	No. 15 No. 14	RXE1- RXE1+
7	TXIN9	GE2	Green Even Pixel Data			
8	TXIN10	GE6	Green Even Pixel Data	TXOUT3- TXOUT3+	No. 9 No. 8	RXE3- RXE3+
10	TXIN11	GE7	Green Even Pixel Data (MSB)			
11	TXIN12	GE3	Green Even Pixel Data	TXOUT1- TXOUT1+	No. 15 No. 14	RXE1- RXE1+
12	TXIN13	GE4	Green Even Pixel Data			
14	TXIN14	GE5	Green Even Pixel Data			
15	TXIN15	BE0	Blue Even Pixel Data (LSB)			
16	TXIN16	BE6	Blue Even Pixel Data	TXOUT3- TXOUT3+	No. 9 No. 8	RXE3- RXE3+
18	TXIN17	BE7	Blue Even Pixel Data (MSB)			
19	TXIN18	BE1	Blue Even Pixel Data	TXOUT1- TXOUT1+	No. 15 No. 14	RXE1- RXE1+
20	TXIN19	BE2	Blue Even Pixel Data	TXOUT2- TXOUT2+	No. 13 No. 12	RXE2- RXE2+
22	TXIN20	BE3	Blue Even Pixel Data			
23	TXIN21	BE4	Blue Even Pixel Data			
24	TXIN22	BE5	Blue Even Pixel Data			
50	TXIN27	RE6	Red Even Pixel Data	TXOUT3- TXOUT3+	No. 9 No. 8	RXE3- RXE3+

5.3 LVDS Interface(2)

5.3.1 Odd Pixel Data (1st pixel data)

LVDS Transmitter (<i>DS90C387</i>) Signal Interface						
Device Input Pin		Device Input Signal		Output Signal	To LTM201U1 Interface (CN101)	
No	Symbol	Symbol	Function		Terminal	Symbol
10	R10	RO0	Red Odd Pixel Data (LSB)	A0M A0P	No. 29 No. 28	RX00- RX00+
9	R11	RO1	Red Odd Pixel Data			
8	R12	RO2	Red Odd Pixel Data			
7	R13	RO3	Red Odd Pixel Data			
6	R14	RO4	Red Odd Pixel Data			
3	R17	RO7	Red Odd Pixel Data (MSB)	A3M A3P	No. 21 No. 20	RX03- RX03+
5	R15	RO5	Red Odd Pixel Data	A0M A0P	No. 29 No. 28	RX00- RX00+
2	G10	GO0	Green Odd Pixel Data (LSB)			
1	G11	GO1	Green Odd Pixel Data	A1M A1P	No. 27 No. 26	RX01- RX01+
100	G12	GO2	Green Odd Pixel Data			
94	G16	GO6	Green Odd Pixel Data	A3M A3P	No. 21 No. 20	RX03- RX03+
93	G17	GO7	Green Odd Pixel Data (MSB)			
99	G13	GO3	Green Odd Pixel Data	A1M A1P	No. 29 No. 28	RX01- RX01+
96	G14	GO4	Green Odd Pixel Data			
95	G15	GO5	Green Odd Pixel Data			
92	B10	BO0	Blue Odd Pixel Data (LSB)	A3M A3P	No. 21 No. 20	RX03- RX03+
86	B16	BO6	Blue Odd Pixel Data			
85	B17	BO7	Blue Odd Pixel Data (MSB)			
91	B11	BO1	Blue Odd Pixel Data	A1M A1P	No. 27 No. 26	RX01- RX01+
90	B12	BO2	Blue Odd Pixel Data	A2M A2P	No. 25 No. 24	RX02- RX02+
89	B13	BO3	Blue Odd Pixel Data			
88	B14	BO4	Blue Odd Pixel Data			
87	B15	BO5	Blue Odd Pixel Data			
4	R16	RO6	Red Odd Pixel Data	A3M A3P	No. 21 No. 20	RX03- RX03+

5.3.2 Even Pixel Data (2nd pixel data)

LVDS Transmitter (<i>DS90C387</i>) Signal Interface						
Device Input Pin		Device Input Signal		Output Signal	To LTM201U1 Interface (CN101)	
No	Symbol	Symbol	Function		Terminal	Symbol
84	R20	RE0	Red Even Pixel Data (LSB)	A4M A4P	No. 17 No. 16	RXE0- RXE0+
81	R21	RE1	Red Even Pixel Data			
80	R22	RE2	Red Even Pixel Data			
79	R23	RE3	Red Even Pixel Data			
78	R24	RE4	Red Even Pixel Data			
75	R27	RE7	Red Even Pixel Data (MSB)	A7M A7P	No. 9 No. 8	RXE3- RXE3+
77	R25	RE5	Red Even Pixel Data	A4M A4P	No. 17 No. 16	RXE0- RXE0+
74	G20	GE0	Green Even Pixel Data (LSB)			
73	G21	GE1	Green Even Pixel Data	A5M A5P	No. 15 No. 14	RXE1- RXE1+
72	G22	GE2	Green Even Pixel Data			
66	G26	GE6	Green Even Pixel Data	A7M A7P	No. 9 No. 8	RXE3- RXE3+
65	G27	GE7	Green Even Pixel Data (MSB)			
71	G23	GE3	Green Even Pixel Data	A5M A5P	No. 15 No. 14	RXE1- RXE1+
70	G24	GE4	Green Even Pixel Data			
69	G25	GE5	Green Even Pixel Data			
64	B20	BE0	Blue Even Pixel Data (LSB)	A7M A7P	No. 9 No. 8	RXE3- RXE3+
58	B26	BE6	Blue Even Pixel Data			
57	B27	BE7	Blue Even Pixel Data (MSB)			
63	B21	BE1	Blue Even Pixel Data	A5M A5P	No. 15 No. 14	RXE1- RXE1+
62	B22	BE2	Blue Even Pixel Data	A6M A6P	No. 13 No. 12	RXE2- RXE2+
61	B23	BE3	Blue Even Pixel Data			
60	B24	BE4	Blue Even Pixel Data			
59	B25	BE5	Blue Even Pixel Data			
76	R26	RE6	Red Even Pixel Data	A7M A7P	No. 9 No. 8	RXE3- RXE3+

NOTE)

Must be connected 24th BAL pin with low and 23th DUAL pin with high in DS90C387 LVDS Transmitter

5.3.3 Timing Diagrams of LVDS For Transmitting
 LVDS Receiver : Integrated T-CON

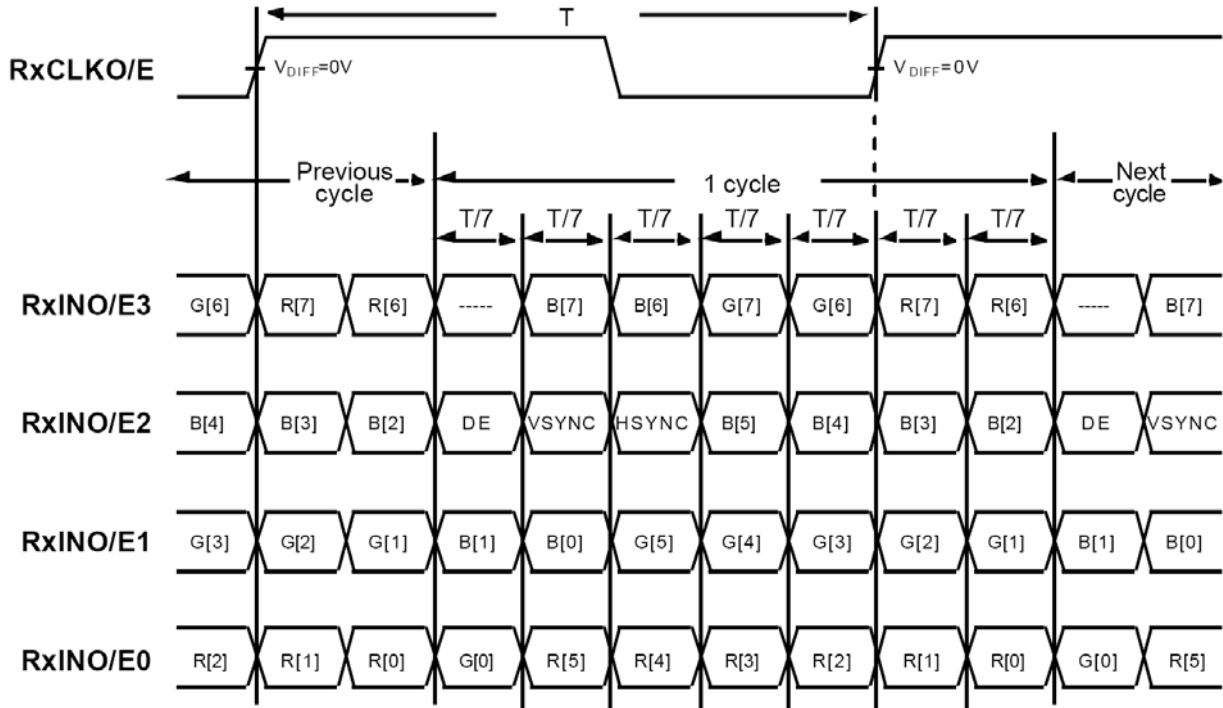

5.4 Back Light Unit

Connector : YeonHo 2pin) 35001WR-02L or equivalent

YeonHo 5pin) 20015HS-05L or equivalent

No	Pin	Symbol	Description	Color	Note
CN1	1	HV	Power Supply for lamp 1(High voltage)	Pink	1
	2	HV	Power Supply for lamp 3(High voltage)	Blue	1
	3	NC	NC		
	4	LV	Power Supply for lamp 1(Low voltage)	Black	2
	5	LV	Power Supply for lamp 3(Low voltage)	Yellow	2
CN2	1	HV	Power Supply for lamp 2(High voltage)	White	1
	2	LV	Power Supply for lamp 2(Low voltage)	White	2
CN4	1	HV	Power Supply for lamp 5(High voltage)	White	1
	2	LV	Power Supply for lamp 5(Low voltage)	White	2
CN3	1	HV	Power Supply for lamp 6(High voltage)	Pink	1
	2	HV	Power Supply for lamp 4(High voltage)	Blue	1
	3	NC	NC		
	4	LV	Power Supply for lamp 6(Low voltage)	Black	2
	5	LV	Power Supply for lamp 4(Low voltage)	Yellow	2

Note (1) The high voltage power terminal is thick line.

(2) The low voltage power terminal is thin line.

5.5 Input Signals, Basic Display Colors and Gray Scale of Each Color

COLO R	DISPLAY (8bit)	DATA SIGNAL																					GRAY SCALE LEVEL			
		RED							GREEN							BLUE										
		R0	R1	R2	R3	R4	R5	R6	R7	G0	G1	G2	G3	G4	G5	G6	G7	B0	B1	B2	B3	B4		B5	B6	B7
BASIC COLO R	BLACK	0	0	0	0	0	0	0	0	0	0	0	0	0	0	0	0	0	0	0	0	0	0	0	0	-
	BLUE	0	0	0	0	0	0	0	0	0	0	0	0	0	0	0	0	1	1	1	1	1	1	1	1	-
	GREEN	0	0	0	0	0	0	0	0	1	1	1	1	1	1	1	1	0	0	0	0	0	0	0	0	-
	CYAN	0	0	0	0	0	0	0	0	1	1	1	1	1	1	1	1	1	1	1	1	1	1	1	1	-
	RED	1	1	1	1	1	1	1	1	0	0	0	0	0	0	0	0	0	0	0	0	0	0	0	0	-
	MAGENTA	1	1	1	1	1	1	1	1	0	0	0	0	0	0	0	0	1	1	1	1	1	1	1	1	-
	YELLOW	1	1	1	1	1	1	1	1	1	1	1	1	1	1	1	1	0	0	0	0	0	0	0	0	-
	WHITE	1	1	1	1	1	1	1	1	1	1	1	1	1	1	1	1	1	1	1	1	1	1	1	1	-
GRAY SCALE OF RED	BLACK	0	0	0	0	0	0	0	0	0	0	0	0	0	0	0	0	0	0	0	0	0	0	0	R0	
	DARK	1	0	0	0	0	0	0	0	0	0	0	0	0	0	0	0	0	0	0	0	0	0	0	R1	
		0	1	0	0	0	0	0	0	0	0	0	0	0	0	0	0	0	0	0	0	0	0	0	R2	
		:	:	:	:	:	:	:	:	:	:	:	:	:	:	:	:	:	:	:	:	:	:	:	R3~ R252	
		:	:	:	:	:	:	:	:	:	:	:	:	:	:	:	:	:	:	:	:	:	:	:		
	LIGHT	1	0	1	1	1	1	1	1	0	0	0	0	0	0	0	0	0	0	0	0	0	0	0	R253	
	0	1	1	1	1	1	1	1	1	0	0	0	0	0	0	0	0	0	0	0	0	0	0	0	R254	
RED	1	1	1	1	1	1	1	1	0	0	0	0	0	0	0	0	0	0	0	0	0	0	0	R255		
GRAY SCALE OF GREEN	BLACK	0	0	0	0	0	0	0	0	0	0	0	0	0	0	0	0	0	0	0	0	0	0	0	G0	
	DARK	0	0	0	0	0	0	0	0	1	0	0	0	0	0	0	0	0	0	0	0	0	0	0	G1	
		0	0	0	0	0	0	0	0	0	1	0	0	0	0	0	0	0	0	0	0	0	0	0	G2	
		:	:	:	:	:	:	:	:	:	:	:	:	:	:	:	:	:	:	:	:	:	:	:	G3~ G252	
		:	:	:	:	:	:	:	:	:	:	:	:	:	:	:	:	:	:	:	:	:	:	:		
	LIGHT	0	0	0	0	0	0	0	0	1	0	1	1	1	1	1	1	0	0	0	0	0	0	0	G253	
	0	0	0	0	0	0	0	0	0	0	1	1	1	1	1	1	1	0	0	0	0	0	0	0	G254	
GREEN	0	0	0	0	0	0	0	0	1	1	1	1	1	1	1	1	0	0	0	0	0	0	0	G255		
GRAY SCALE OF BLUE	BLACK	0	0	0	0	0	0	0	0	0	0	0	0	0	0	0	0	0	0	0	0	0	0	0	B0	
	DARK	0	0	0	0	0	0	0	0	0	0	0	0	0	0	0	0	1	0	0	0	0	0	0	B1	
		0	0	0	0	0	0	0	0	0	0	0	0	0	0	0	0	0	1	0	0	0	0	0	B2	
		:	:	:	:	:	:	:	:	:	:	:	:	:	:	:	:	:	:	:	:	:	:	:	B3~ B252	
		:	:	:	:	:	:	:	:	:	:	:	:	:	:	:	:	:	:	:	:	:	:	:		
	LIGHT	0	0	0	0	0	0	0	0	0	0	0	0	0	0	0	0	1	0	1	1	1	1	1	B253	
	0	0	0	0	0	0	0	0	0	0	0	0	0	0	0	0	0	0	1	1	1	1	1	1	B254	
BLUE	0	0	0	0	0	0	0	0	0	0	0	0	0	0	0	0	1	1	1	1	1	1	1	B255		

Note (1) Definition of Gray :

Rn : Red Gray, Gn : Green Gray, Bn : Blue Gray (n = Gray level)

Input Signal : 0 = Low level voltage, 1 = High level voltage

6. Interface Timing

6.1 Timing Parameters (DE only mode)

SIGNAL	ITEM	SYMBOL	MIN.	TYP.	MAX.	Unit	NOTE
Clock	Frequency	$1/T_C$	64	65.125	66.25	MHz	(1)
Hsync		F_H	72	74	76	KHz	
Vsync		F_V	59	60	61	Hz	
Vertical Active Display Term	Display Period	T_{VD}	1200	1200	1200	lines	-
	Blank Period	T_{VB}	29	-	-	lines	(2)
Horizontal Active Display Term	Display Period	T_{HD}	800	800	800	clocks	(2)
One line scanning tiem	Cycle	T_H	850	880	-	clocks	(2)

Note (1) Test Point : TTL control signal and CLK at LVDS Tx input terminal in system

(2) VESA UXGA Coordinated Video Timing (Reduced Blanking)

6.2 Timing diagrams of interface signal (DE only mode)

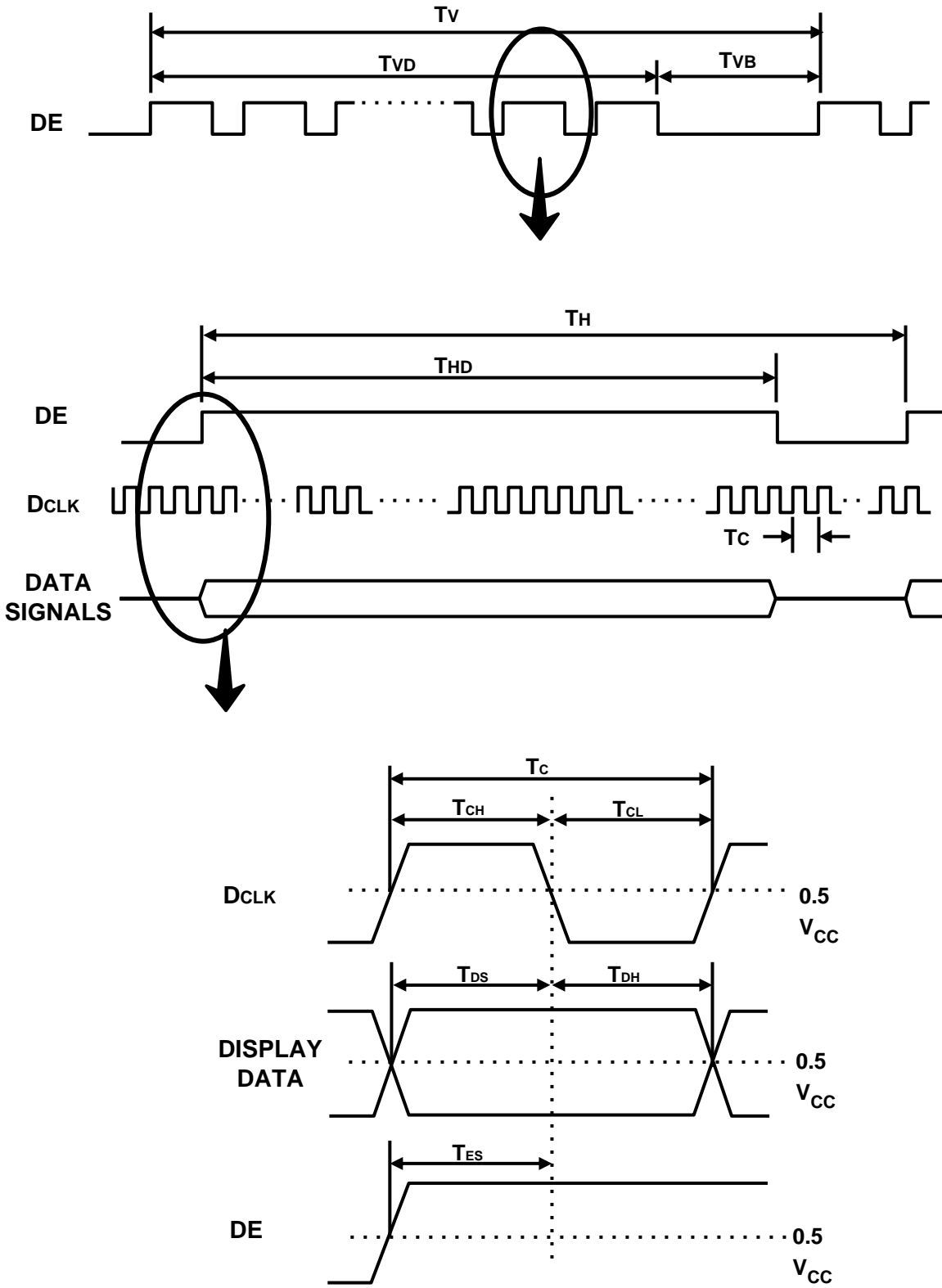

6.3 Power ON/OFF Sequence

To prevent a latch-up or DC operation of the LCD Module, the power on/off sequence should be as the diagram below.

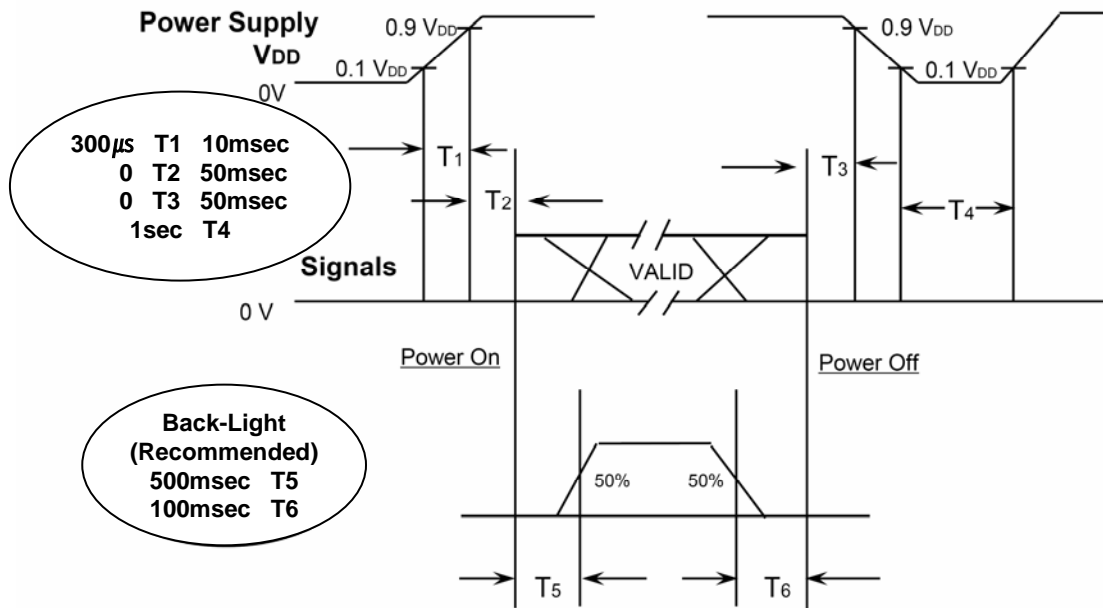

- T1 : V_{DD} rising time from 10% to 90%
- T2 : The time from V_{DD} to valid data at power ON.
- T3 : The time from valid data off to V_{DD} off at power Off.
- T4 : V_{DD} off time for Windows restart
- T5 : The time from valid data to B/L enable at power ON.
- T6 : The time from valid data off to B/L disable at power Off.

- The supply voltage of the external system for the Module input should be the same as the definition of V_{DD}.
- Apply the lamp voltage within the LCD operation range. When the back light turns on before the LCD operation or the LCD turns off before the back light turns off, the display may momentarily show abnormal screen.
- In case of V_{DD} = off level, please keep the level of input signals low or keep a high impedance.
- T4 should be measured after the Module has been fully discharged between power off and on period.
- Interface signal should not be kept at high impedance when the power is on.

6.5 VDD Power Dip Condition

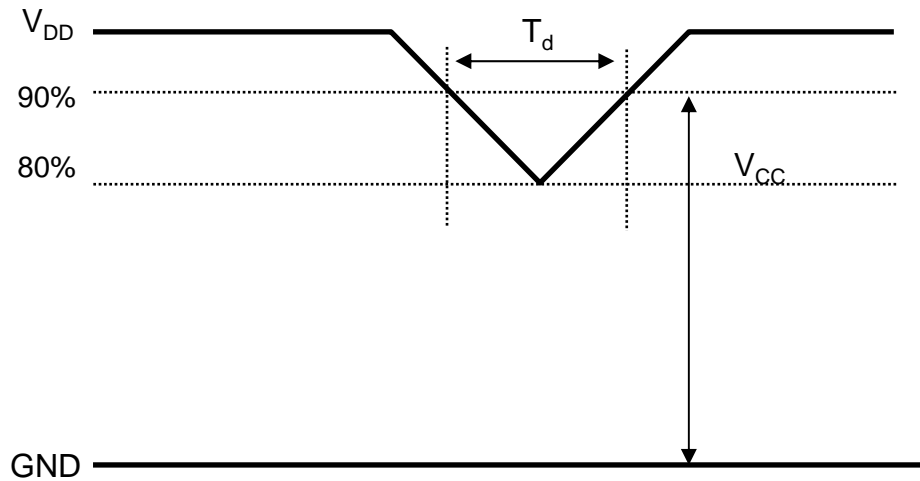

$\begin{array}{c} 4.5V \quad V_{DD} \quad 5.5V \\ \text{If } V_{DD}(\text{typ.}) \times 80\% \quad V_{CC} \quad V_{DD}(\text{typ.}) \times 90\% \\ \text{Then, } 0 < T_d < 20\text{msec} \end{array}$

- Note (1) The above conditions are for the glitch of the input voltage.
 (2) For stable operation of an LCD Module power, please follow them.
 i.e., if $\text{typ } V_{DD} \times 80\% \quad V_{CC} \quad \text{typ } V_{DD} \times 90\%$, then T_d should be less than 20ms.

7. Outline Dimension

[Refer to the next page]

Approval Specification

MODEL

LTM201U1 -L01

Doc. No

05 -E00 -G -051108

Page

32/40

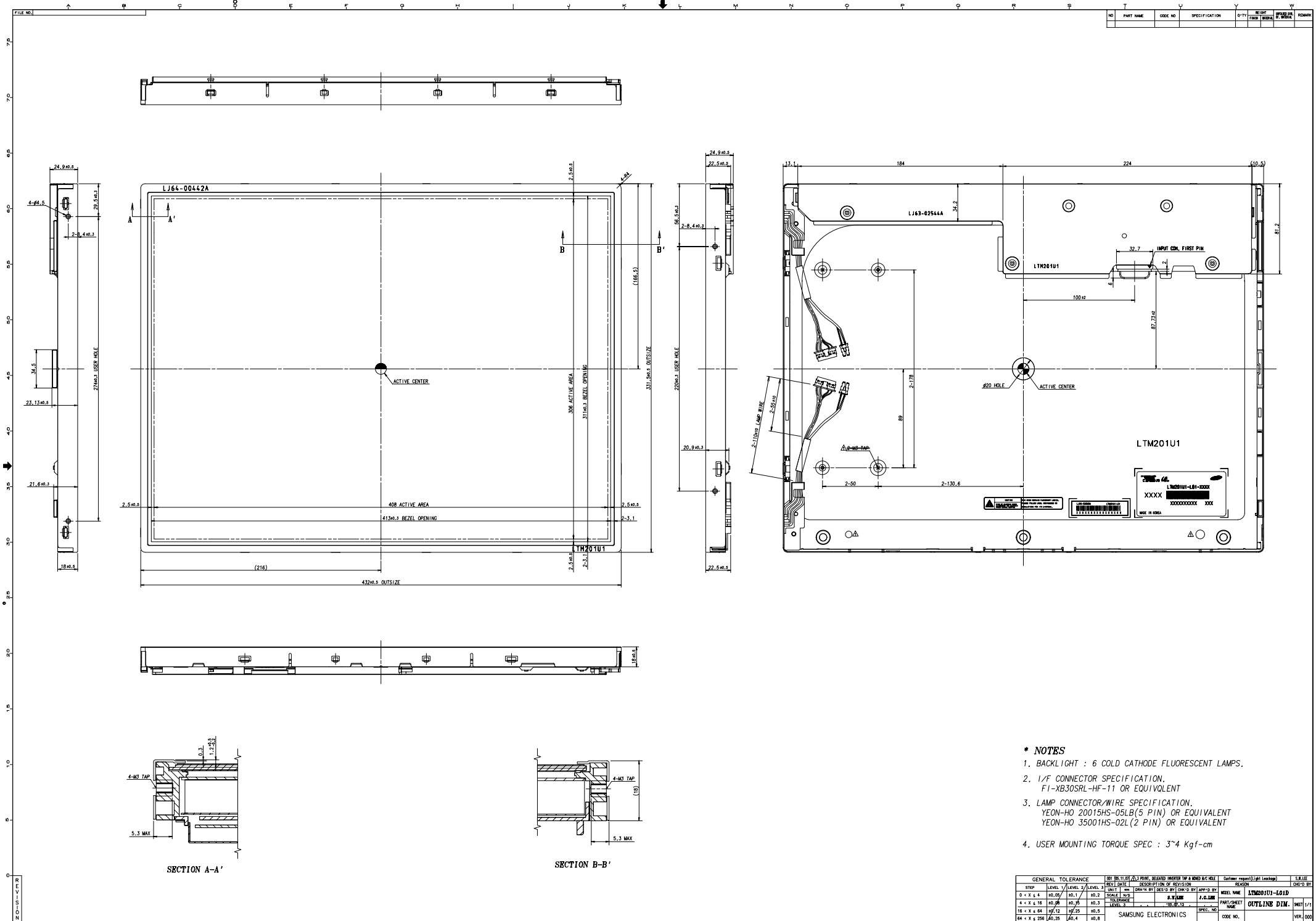

- * NOTES**
- BACKLIGHT : 6 COLD CATHODE FLUORESCENT LAMPS.
 - I/F CONNECTOR SPECIFICATION.
FI-XB30SRL-HF-11 OR EQUIVLENT
 - LAMP CONNECTOR/WIRE SPECIFICATION.
YEON-HO 20015HS-05LB(5 PIN) OR EQUIVALENT
YEON-HO 35001HS-02L(2 PIN) OR EQUIVALENT
 - USER MOUNTING TORQUE SPEC : 3~4 Kgf-cm

STEP	LEVEL 1	LEVEL 2	LEVEL 3	LEVEL 4	LEVEL 5	LEVEL 6	LEVEL 7	LEVEL 8	LEVEL 9	LEVEL 10	LEVEL 11	LEVEL 12	LEVEL 13	LEVEL 14	LEVEL 15	LEVEL 16	LEVEL 17	LEVEL 18	LEVEL 19	LEVEL 20	LEVEL 21	LEVEL 22	LEVEL 23	LEVEL 24	LEVEL 25	LEVEL 26	LEVEL 27	LEVEL 28	LEVEL 29	LEVEL 30	LEVEL 31	LEVEL 32	LEVEL 33	LEVEL 34	LEVEL 35	LEVEL 36	LEVEL 37	LEVEL 38	LEVEL 39	LEVEL 40	LEVEL 41	LEVEL 42	LEVEL 43	LEVEL 44	LEVEL 45	LEVEL 46	LEVEL 47	LEVEL 48	LEVEL 49	LEVEL 50									
GENERAL TOLERANCE																														SAMSUNG ELECTRONICS																													
CODE NO.																														CODE NO.																													
PART NAME																														PART NAME																													
SPECIFICATION																														SPECIFICATION																													
QUANTITY																														QUANTITY																													
UNIT																														UNIT																													
DRAWN BY																														DRAWN BY																													
CHECKED BY																														CHECKED BY																													
DATE																														DATE																													
MODEL NAME																														MODEL NAME																													
PART NAME																														PART NAME																													
PAGE																														PAGE																													
SPEC. NO.																														SPEC. NO.																													
VER.																														VER.																													

8. Reliability Test

Test Items	Conditions	Time/Cycle	Sample
HTOL*	50°C , Bias	500 hrs	12
LTOL*	0°C , Bias	500 hrs	5
THB**	40°C / 95% , Bias	500 hrs	5
HTS***	70°C , No Bias	500 hrs	5
LTS***	-30°C , No Bias	500 hrs	5
Thermal Cycle	-20°C/30min ~ +60°C/30min , No bias	100 cycle	5
Box Drop	1 angle , 3 edge , 6 side , 66 cm		5
Shock (Non-operating)	50G , 11msec Sine wave , ± x/y/z axis	1 time/axis	3
Vibration (Non-operating)	1.5G , 10~300 Hz x/y/z axis , sweep rate : 10 min	30min/axis	3
ESD	Non-Operating CDM : 150pF, 330 , 9point, 3 times/point	± 10kV	3
	Operating Contact : 150pF, 330 , 100point, once/point	± 8kV	3
		Air(non-contact) : 150pF, 330 , 100point, once/point	± 15kV
Altitude	Operating : 0~10,000ft	72hrs	3
	Non-operating : 0~50,000ft		3

[Result Evaluation Criteria]

Under the display quality test conditions with normal operation state, these should be no change which may affect practical display functions.

* HTOL/ LTOL : High/Low Temperature Operating Life

** THB : Temperature Humidity Bias

*** HTS/LTS : High/Low Temperature Storage

9. PACKING

9.1 CARTON (Internal Package)

(1) Packing Form

Corrugated fiberboard box and EPS Cushion as shock absorber

(2) Packing Method

a) Without Inverter

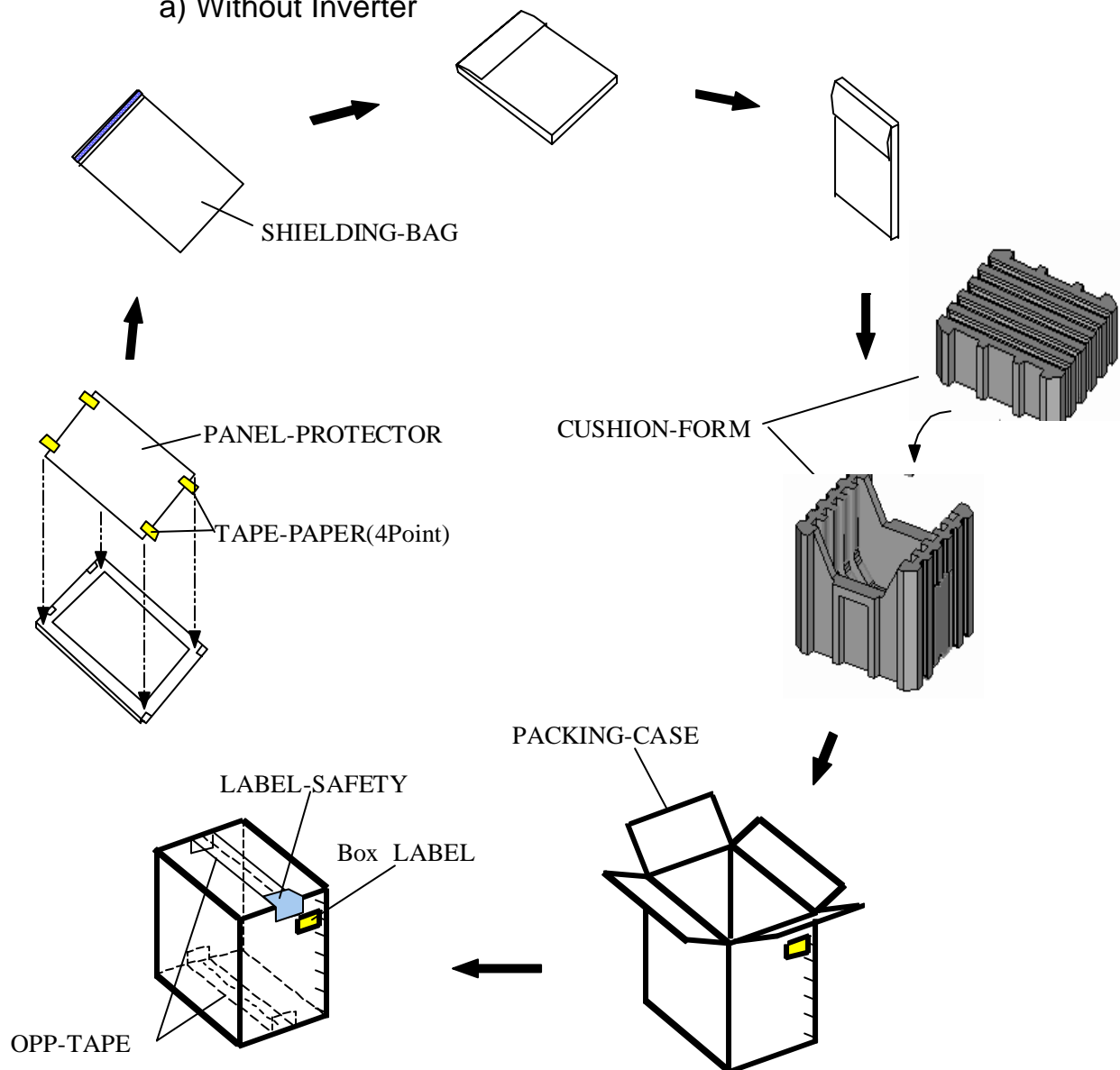

- Note
- (1) TOTAL : Approx. 17.0kg
 - (2) Acceptance number of piling : 5sets
 - (3) Carton size : 418(W) X 367(D) X 523(H)
 - (4) MAX accumulation quantity : 5 cartons

(3) Packing Material

No	Part name	Quality
1	Static electric protective sack	5
2	Packing case (Inner box) included shock absorber	1 set
3	Pictorial marking	2 pics
4	Carton	1 set

10. MARKING & OTHERS

A nameplate bearing followed by is affixed to a shipped product at the specified location on each product.

- (1) Parts number : LTM201U1-L01
 (2) Revision: Three letters
 (3) Lot number : X X X X XXX XX X

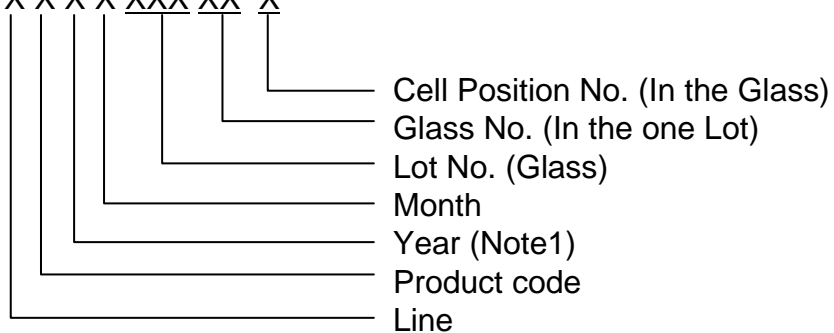

Note (1) This code indicating year is omitted in the products of KIHENG site.

(4) Nameplate Indication

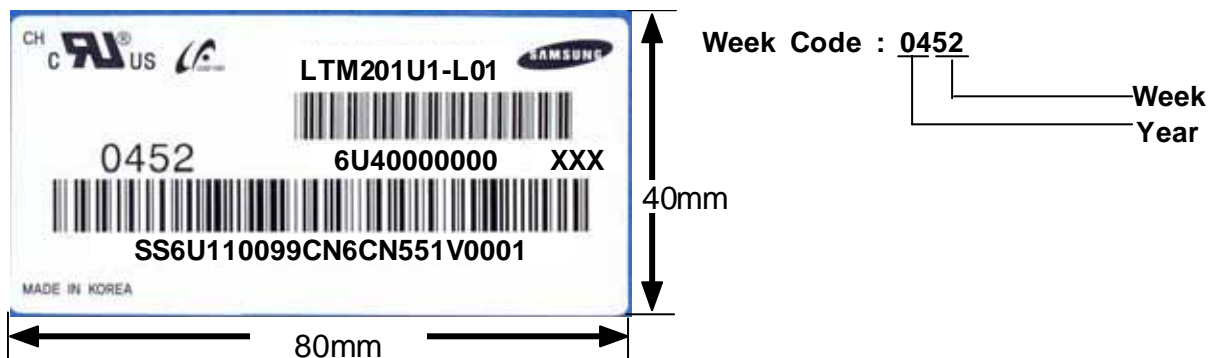

(5) Packing box attach

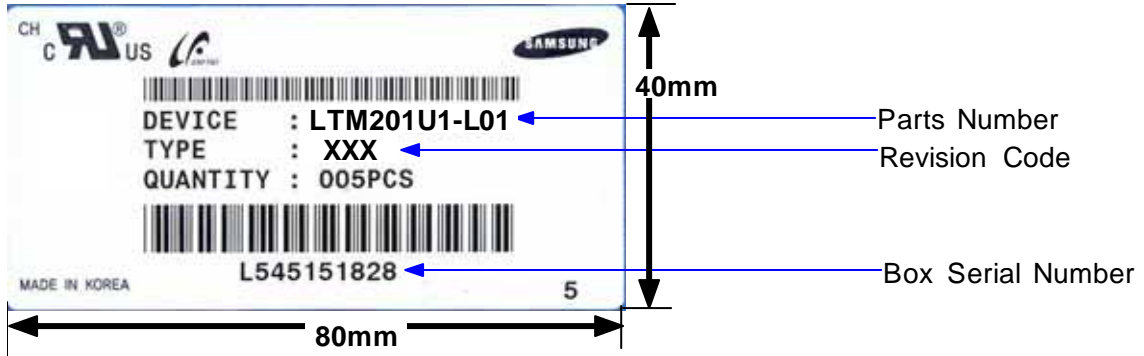

(6) Others

a. After service part

Part Name	Description
ASS'Y-LAMP(U)	LJ91-00748A, LTM201U1, D2.4, L420
ASS'Y-LAMP(L)	LJ91-00749A, LTM201U1, D2.4, L420

11. General Precautions

11.1 Handling

- (a) When the module is assembled, it should be attached to the system firmly using all mounting holes. Be careful not to twist and bend the module.
- (b) Because the inverter uses high voltages, it should be disconnected from power source before it is assembled or disassembled.
- (c) Refrain from strong mechanical shock and / or any force to the module. In addition to damage, it may cause improper operation or damage to the module and CCFT back light.
- (d) Note that polarizer films are very fragile and could be damaged easily. Do not press or scratch the surface harder than a HB pencil lead.
- (e) Wipe off water droplets or oil immediately. If you leave the droplets for a long time, staining or discoloration may occur.
- (f) If the surface of the polarizer is dirty, clean it using absorbent cotton or soft cloth.
- (g) Desirable cleaners are water, IPA (Isopropyl Alcohol) or Hexane. Do not use Ketone type materials (ex. Acetone), Ethyl alcohol, Toluene, Ethyl acid or Methyl chloride. It might cause permanent damage to the polarizer due to chemical reaction.
- (h) If the liquid crystal material leaks from the panel, it should be kept away from the eyes or mouth . In case of contact with hands, legs or clothes, it must be washed away with soap thoroughly.
- (i) Protect the Module from static, or the CMOS Gate Array IC would be damaged.
- (j) Use finger-stalls with soft gloves in order to keep display clean during the incoming inspection and assembly process.
- (k) Do not disassemble the Module.
- (l) Do not pull or fold the lamp wire.
- (m) Do not adjust the variable resistor located on the Module.
- (n) Protection film for polarizer on the Module should be slowly peeled off just before use so that the electrostatic charge can be minimized.
- (o) Pins of I/F connector should not be touched directly with bare hands.

11.2 Storage

- (a) Do not leave the Module in high temperature, and high humidity for a long time. It is highly recommended to store the Module with temperature from 0 to 35 and relative humidity of less than 70%.
- (b) Do not store the TFT-LCD Module in direct sunlight.
- (c) The Module should be stored in a dark place. It is prohibited to apply sunlight or fluorescent light in storing.

11.3 Operation

- (a) Do not connect or disconnect the Module in the "Power On" condition.
- (b) Power supply should always be turned on/off by the item 6.3 "Power on/off sequence"
- (c) Module has high frequency circuits. Sufficient suppression to the electromagnetic interference should be done by system manufacturers. Grounding and shielding methods may be important to minimize the interference.
- (d) The cable between the back light connector and its inverter power supply should be connected directly with a minimized length. A longer cable between the back light and the inverter may cause lower luminance of lamp(CCFT) and may require higher startup voltage(Vs).

11.4 Operation Condition Guide

- (a) The LCD product should be operated under normal conditions.
Normal condition is defined as below;
 - Temperature : 20 ± 15
 - Humidity : $65 \pm 20\%$
 - Display pattern : continually changing pattern (Not stationary)
- (b) If the product will be used in extreme conditions such as high temperature, humidity, display patterns or operation time etc., It is strongly recommended to contact SEC for Application engineering advice. Otherwise, its reliability and function may not be guaranteed. Extreme conditions are commonly found at Airports, Transit Stations, Banks, Stock market, and Controlling systems.

11.5 Others

- (a) Ultra-violet ray filter is necessary for outdoor operation.
- (b) Avoid condensation of water. It may result in improper operation or disconnection of electrode.
- (c) Do not exceed the absolute maximum rating value. (supply voltage variation, input voltage variation, variation in part contents and environmental temperature, and so on)
Otherwise the Module may be damaged.
- (d) If the Module keeps displaying the same pattern for a long period of time, the image may be "sticked" to the screen.
To avoid image sticking, it is recommended to use a screen saver.
- (e) This Module has its circuitry PCB's on the rear side and should be handled carefully in order not to be stressed.
- (f) Please contact SEC in advance when you display the same pattern for a long time.