

## PRODUCT INFORMATION

## FEATURES

- 3.5"QVGA(240x320pixels) display size for PDA & palm.
- Reflective LCD & built-in CCFL Front light.

**TENTATIVE**

## MECHANICAL SPECIFICATIONS

Item	Specifications
Dimensional Outline (typ.)	70.0(W) x 92.2/87.2(H) x 5.1(D) mm
Number of Pixels	240(x RGB)(W) x 320 (H) pixels
Active Area	53.64(W) x 71.52 (H) mm
Pixel Pitch	0.2235(W) x 0.2235 (H)
Weight (approximately)	(50g)
Front Light	Single CCFL, Front light type

## ABSOLUTE MAXIMUM RATINGS

Item		Min.	Max.	Unit
LCD Supply Voltage	(DVDD)	-0.3	(4.0)	V
	(AVDD)	-0.3	(6.0)	V
	(VGH)	-0.3	(20)	V
	(VGL)	(-20)	0.3	V
	(GVDD)	VGL-0.3	VGL+4	V
FL Driving Voltage	(VFL)	0	2.0	kV(rms)
FL Driving Frequency	(fFL)	-	200	kHz
Input Signal Voltage	(VIN)	-0.3	DVDD+0.3	V
Operating Temperature		0	50	°C
Storage Temperature		-20	60	°C
Storage Humidity (Max. wet bulb temp. = 39°C)		10	90	%(RH)

## ELECTRICAL SPECIFICATION

Item		Min.	Typ.	Max.	Unit	Remarks
LCD Supply Voltage	(DVDD)	3.1	3.3	3.5	V	
	(AVDD)	4.75	5.0	5.25	V	
	(VGH)	14.0	15.0	16.0	V	
	(VGL)	-13.0	-12.0	-11.0	V	
	(GVDD)	VGL+3.1	VGL+3.3	VGL+3.5	V	
FL Driving Voltage	(VFL)	310	345	390	V(rms)	$I_{FL}=1.4\text{mA(rms)}$
FL Start Voltage ( $T_a=0^\circ\text{C}$ )	(VFLS)	---	---	1100	V(rms)	
FL Driving Frequency	(fFL)	50	55	60	kHz	
High Level Input Voltage	(VH)	$0.8 V_{DD}$	---	$V_{DD}$	V	
Low Level Input Voltage	(VL)	0	---	$0.2 V_{DD}$	V	
LCD Current Consumption	*1 (D/DD)	---	1.2	2.4	mA	
	*1 (A/DD)	---	7.8	15.0	mA	
	*1 (G/H)	---	25	50	uA	
	*1 (G/L)	---	270	540	uA	
	*1 (G/DD)	---	2	4	uA	
FL Current Consumption	*2 ( $I_{FL}$ )	1.0	1.4	3.0	mA(rms)	
*1 Power Consumption for LCD & G/A		---	46	---	mW	
*2 Power Consumption of Flontlight		---	0.5	---	W	@40cd/m <sup>2</sup>

\*1 : 8 color bars pattern

(Including recommended LCD Controller ,Gray scale resister, Vcom circuit and ZD circuit.)

\*2 : Excepting the efficiency FL inverter

OPTICAL SPECIFICATION ( $T_a=25^\circ\text{C}$ )

Item		Min.	Typ.	Max.	Unit	Remarks
Contrast Ratio (CR)		---	15	---	---	
Response Time	( $t_{ON}$ )	---	---	50	ms	
	( $t_{OFF}$ )	---	---	50	ms	
Luminance (L)		30	40	---	cd/m <sup>2</sup>	$I_{FL}=1.4\text{mA(rms)}$

\*The information contained herein is presented only as a guide for the applications of our products. No responsibility is assumed by Toshiba Matsushita Display Technology Co.,Ltd. or other rights of the third parties which may result from its use. No license is granted by implication or otherwise under any patent or patent rights of Toshiba Matsushita Display Technology Co.,Ltd. or others.

\*The information contained herein may be changed without prior notice. It is therefore advisable to contact Toshiba Matsushita Display Technology Co.,Ltd. before proceeding with the design of equipment incorporating this product.

**DIMENSIONAL OUTLINE (front figure)**

Unit : mm

Standard tolerance :  $\pm 0.3$

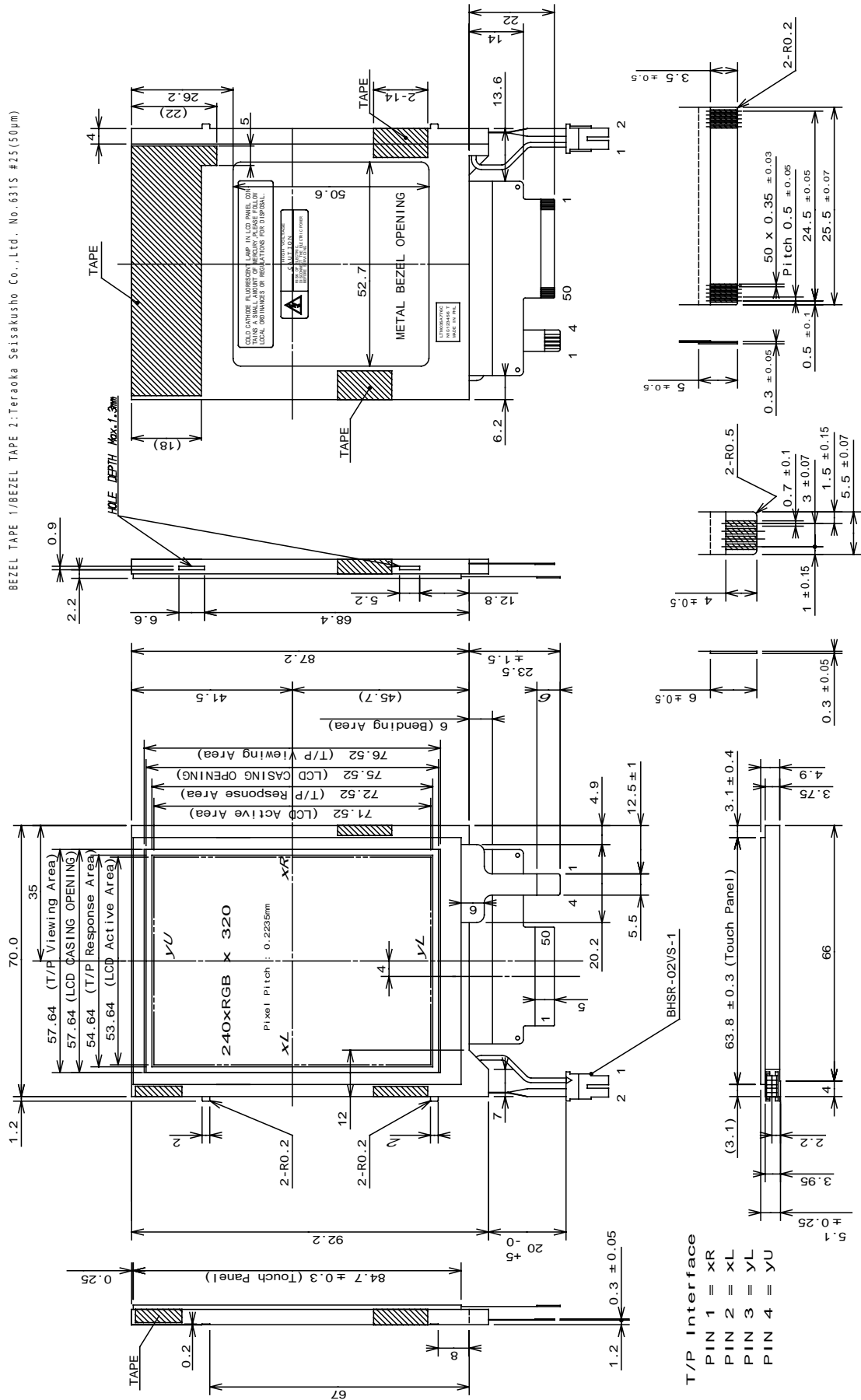

**BLOCK DIAGRAM**

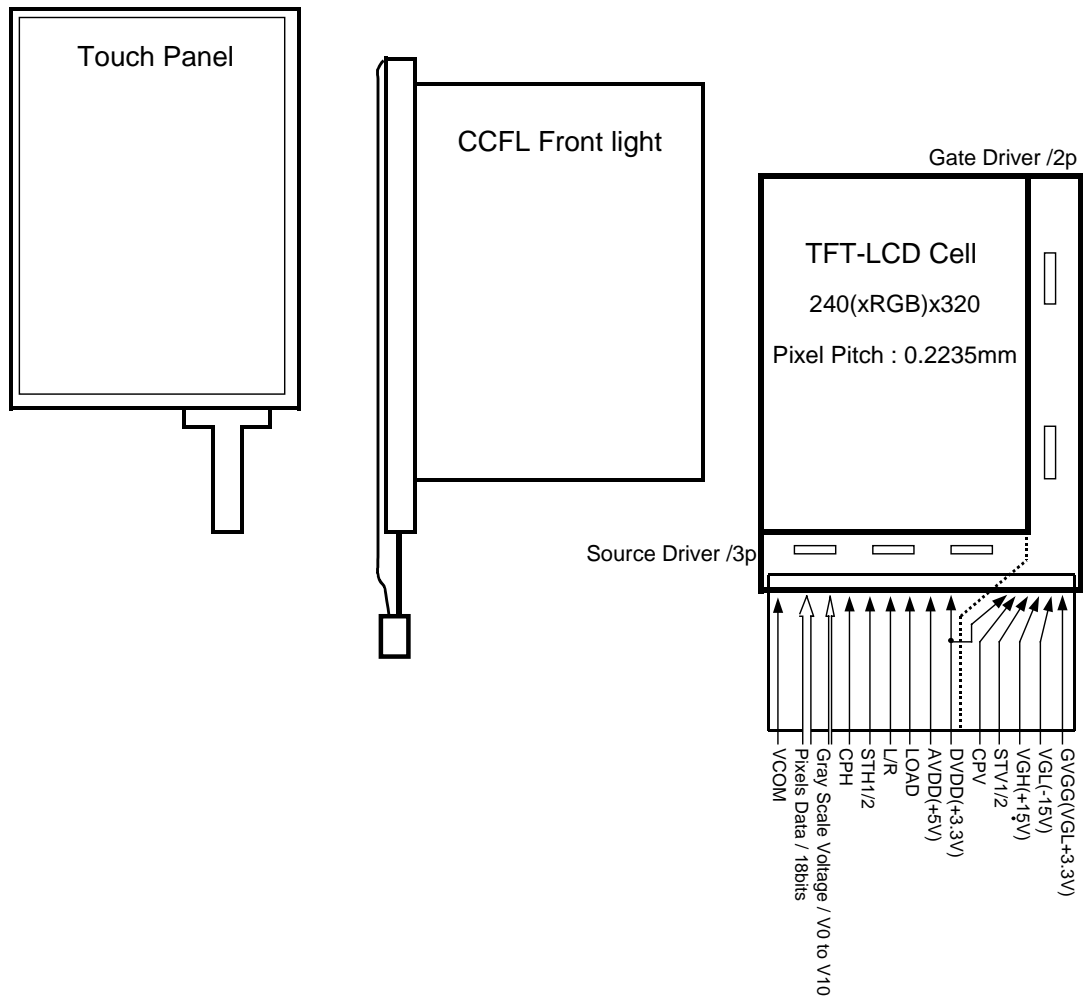

**Note : Mating Connector**

- LCD I/F FPC : Hirose / FH12-50S-0.5SH, Molex / 54132-5090
- CCFL Front Light : JST / SM02B-BHS-1
- Touch Panel : Hirose / FH12-10(4)SA-1SH(05)

**Application**

As an example of design for MPU; Strong ARM(SA-1110) and Original Panel Controller.

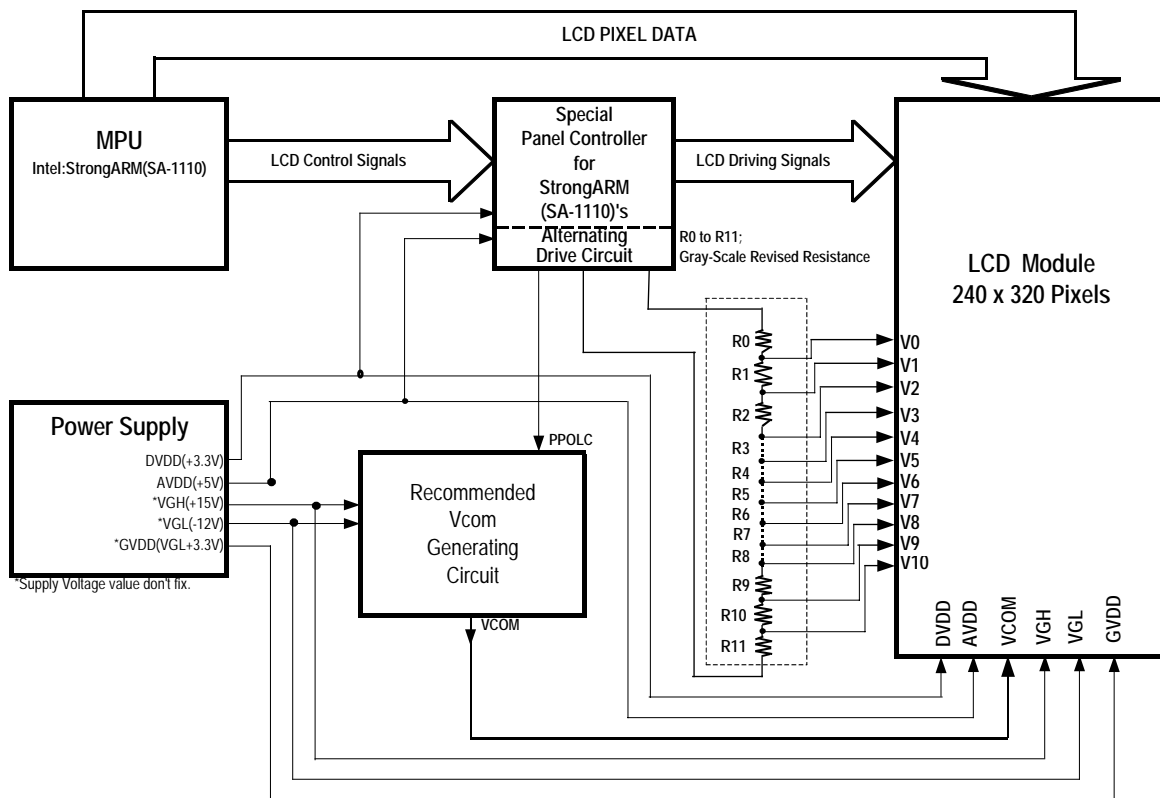

**Recommended VCOM circuit**

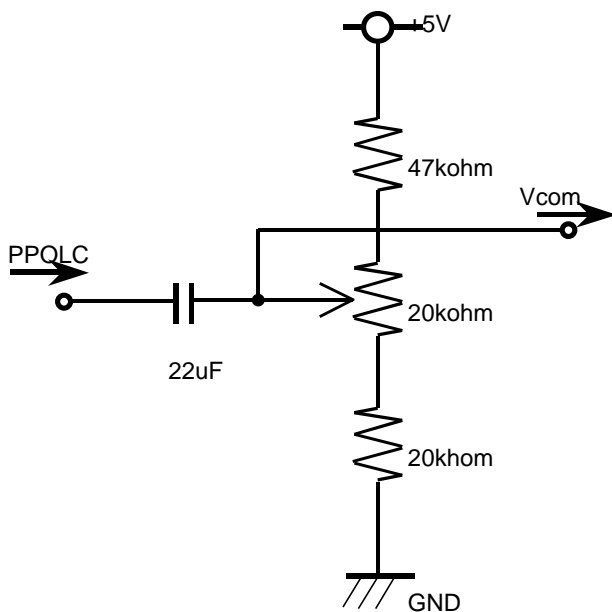

## Application

As an example of design for MPU and Media Q (MQ-1110/1132).

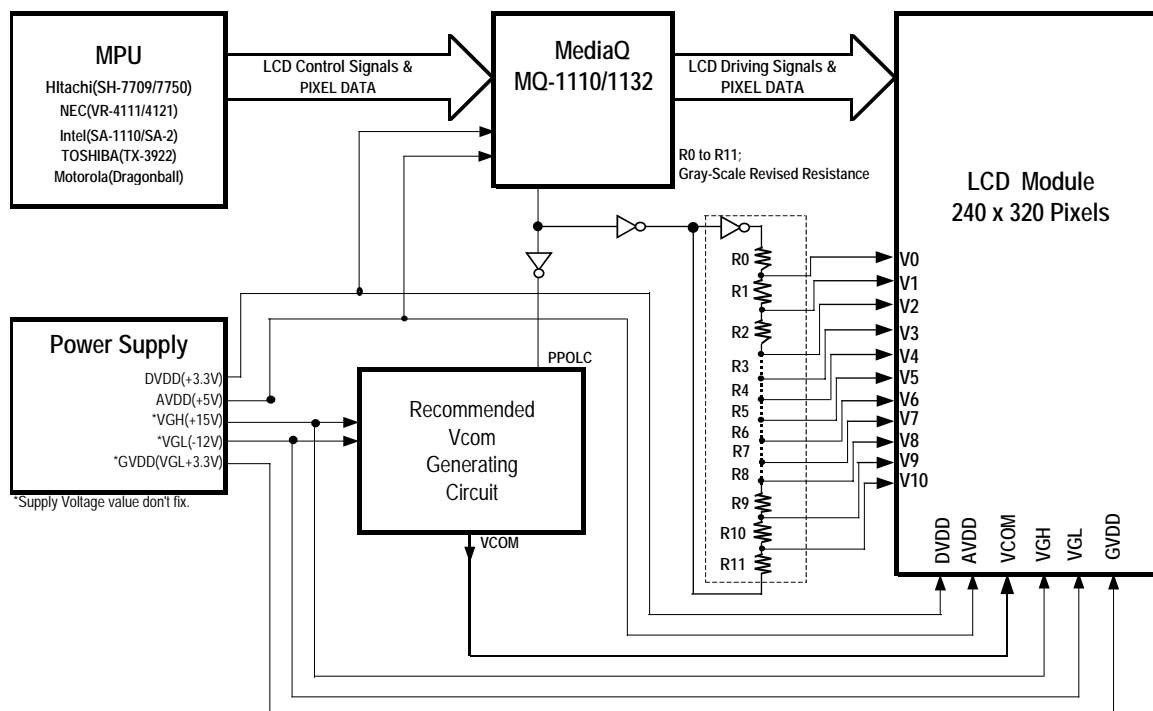

## PIN ASSIGNMENT BETWEEN MediaQ and LCD Module

Media Q		LCD Module	
Terminal No.	Symbol	Terminal No.	Symbol
---	+5V	1	AVDD
---	+5V	2	AVDD
---	FDE	3	STH1(DI/O)
FD18	R0	4	R0
FD19	R1	5	R1
FD20	R2	6	R2
FD21	R3	7	R3
FD22	R4	8	R4
FD23	R5	9	R5
FD10	G0	10	G0
FD11	G1	11	G1
FD12	G2	12	G2
FD13	G3	13	G3
FD14	G4	14	G4
FD15	G5	15	G5
---	V0	16	V0
---	V1	17	V1
---	V2	18	V2
---	V3	19	V3
---	V4	20	V4
---	V5	21	V5
---	V6	22	V6
---	V7	23	V7
---	V8	24	V8
---	V9	25	V9

Media Q		LCD Module	
Terminal No.	Symbol	Terminal No.	Symbol
---	V10	26	V10
---	+3.3V	27	DVDD
---	FHSYNC	28	LOAD
---	(Open)	29	STH2(DO/I)
---	+3.3V	30	L/R
---	FSCLK	31	CPH
FD2	B0	32	B0
FD3	B1	33	B1
FD4	B2	34	B2
FD5	B3	35	B3
FD6	B4	36	B4
FD7	B5	37	B5
---	GND	38	VSS
---	GND	39	VSS
---	---	40	Vcom
---	---	41	Vcom
---	(Open)	42	STV2
---	-9 V	43	GVDD(VCC)
---	GND	44	VSS
---	GND	45	U/D
---	FLCLK	46	CPV
---	-8.7V	47	DVDD
---	-12V	48	VGL(VEE)
---	+15V	49	VGH(VGG)
---	FVSYNC	50	STV1

Gray-Scale Revised Resistance value (Draft)

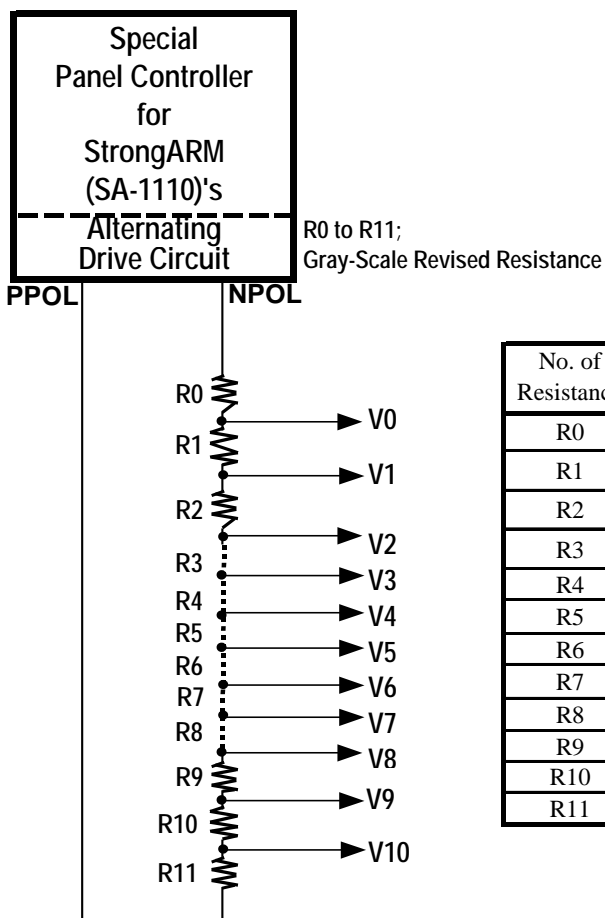

No. of Resistance	Tentative Value	Unit	Tolerance	Power Rating
R0	0	k ohm	0.5%	$\geq 1/16W$
R1	6.2	k ohm	0.5%	$\geq 1/16W$
R2	6.2	k ohm	0.5%	$\geq 1/16W$
R3	2.2	k ohm	0.5%	$\geq 1/16W$
R4	1.5	k ohm	0.5%	$\geq 1/16W$
R5	1.1	k ohm	0.5%	$\geq 1/16W$
R6	1.0	k ohm	0.5%	$\geq 1/16W$
R7	1.0	k ohm	0.5%	$\geq 1/16W$
R8	1.3	k ohm	0.5%	$\geq 1/16W$
R9	2.7	k ohm	0.5%	$\geq 1/16W$
R10	6.8	k ohm	0.5%	$\geq 1/16W$
R11	0	k ohm	0.5%	$\geq 1/16W$

Polarity of the Alternated signals (VCOM, V0, V10)

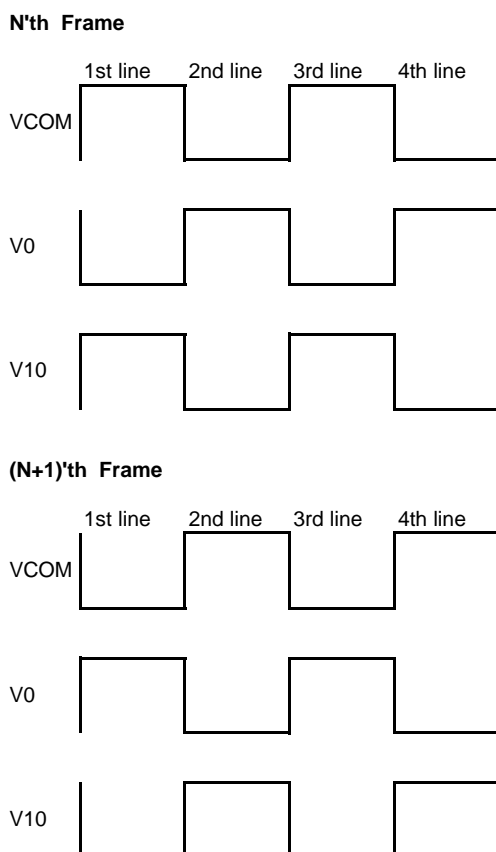

### TIMING CHART(LCD Interface)

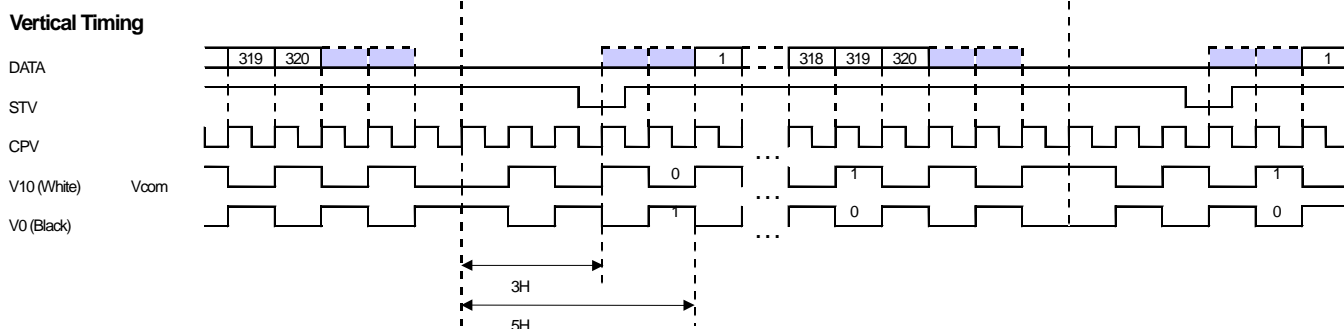
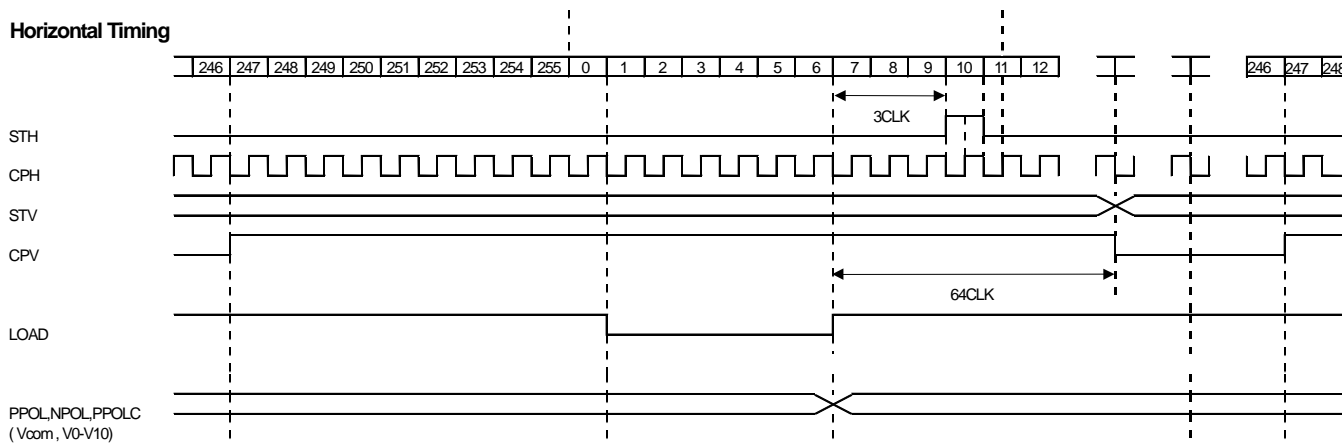

 Dummy line  
 LCD panel have 4 dummy line. (upper side : 2 line / lower side : 2 line)

Gate Driver output : 162  
 LCD panel use to 2 Gate Driver.

### Pixels Location

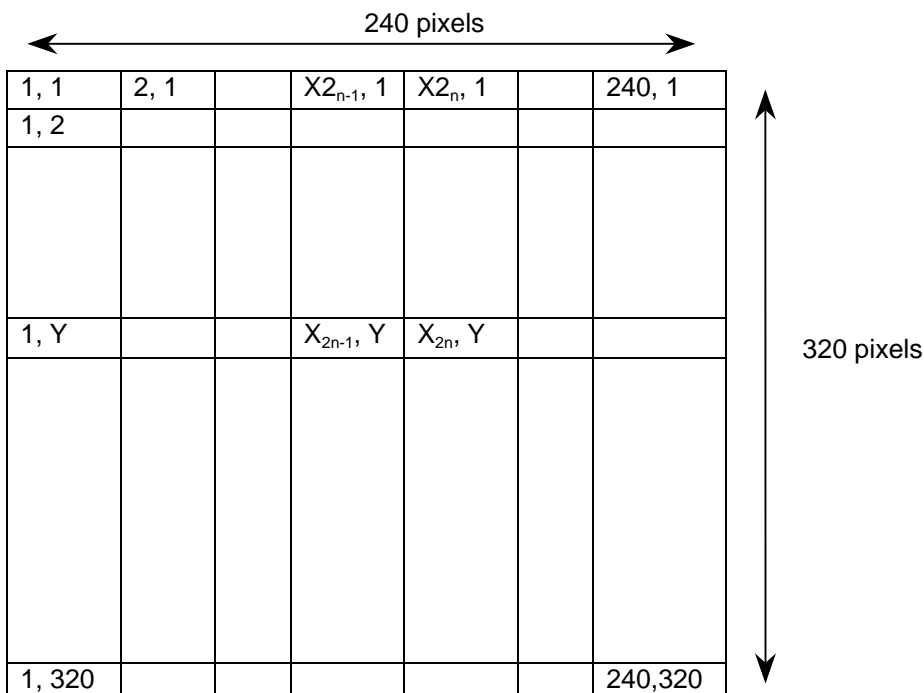

## AC TIMING CHART for input Signal of the recommended Panel Controller

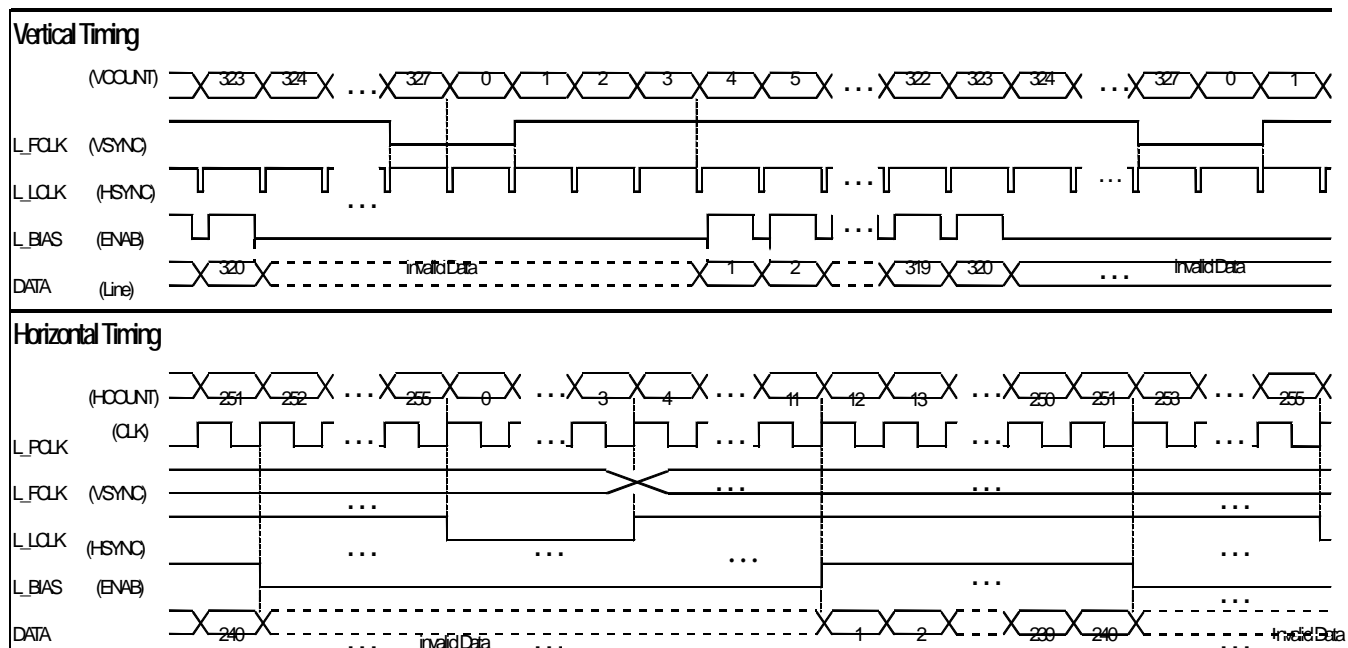
**MPU(StrongARMSA-1110) LCD Control Signals Output Timing (Toshiba's Requirement)****Horizontal Timing**

FH	16.7 to 18.5	KHz
H period	256	Pixels
	54 min.	Us
H disp area	240	Pixels
H sync width	4	Pixels
H back porch	8	Pixels
H front porch	4	Pixels
H sync pol	Neg.	

**Vertical Timing**

FV	51 to 56	KHz
V period	328	H(Line)
V disp area	320	H(Line)
V sync width	2	H(Line)
V back porch	3	H(Line)
V front porch	3	H(Line)
V sync pol	Neg.	
Pixels CLK	4.28 to 4.702	MHz



## Sequence of Power Supplies and Signals

Turn on or off the power and signal supply sequence is as follows.

Turn on ; DVDD -> logic signal -> AVDD, Vcom -> VGL, GVDD -> VGH

Turn off ; VGL -> GVDD, logic signal, DVDD, VGH -> AVDD, Vcom

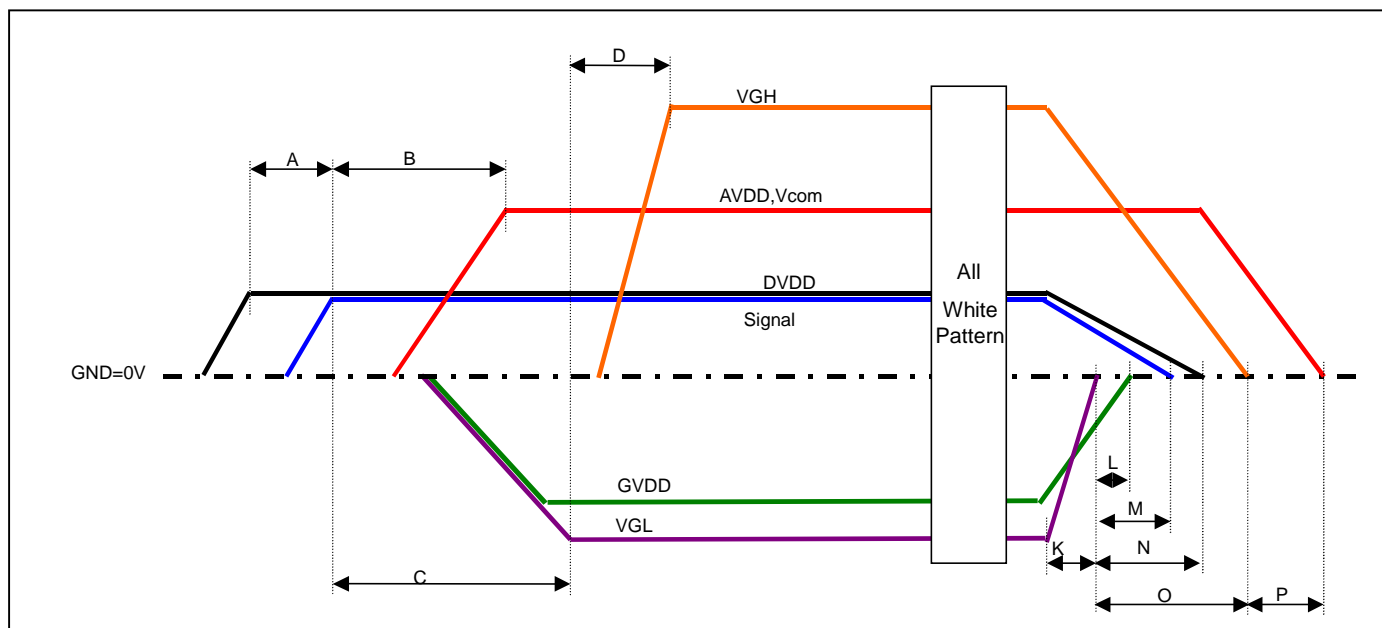

		Power Souse		Condition	Specifications	
Power on Sequence	1	DVDD				
	2	Signal	A	DVDD=3.3V >> Signal=3.3V	1ms to 10ms	
	3	AVDD, Vcom	B	Signal=3.3V >> AVDD=5.0V	0 to 10ms	
	4	GVDD	C	Signal=3.3V >> GVDD= - 8.7V	0 to 10ms	
	4	VGL	C	Signal=3.3V >> VGL= - 12V	0 to 10ms	
	5	VGH	D	VGL= - 12V >> VGH=15V	-10ms to 10ms	
Power off Sequence	1	Writing All white Pattern (Toshiba recommended)				
	2	VGL	K	VGL=100% >> VGL=0%	max.10ms	
	3	GVDD	L		-10ms to 10ms	
	3	Signal	M		-10ms to 10ms	
	3	DVDD	N		-10ms to 10ms	
	3	VGH	O		-10ms to 10ms	
	4	AVDD, Vcom	P		10ms to 20ms	

**CONNECTOR PIN ASSIGNMENT FOR INTERFACE****CN1 FPC (pin Assignment)**

(Mating Connector; 0.5mm Pitch : Example; Hirose/FH12-50S-0.5SH, Molex/54132-5090)

Terminal No.	Symbol	Function	I/O	Comment
1	AVDD	Power Supply (+5.0V)	Input	for LCD signal voltage
2	AVDD	Power Supply (+5.0V)	Input	for LCD signal voltage
3	STH1(DI/O)	Horizontal start pulse (Normal)	Input	L/R="H"; STH Signal Input, L/R="L"; Open
4	R0	Red Pixels DATA (LSB)	Input	
5	R1	Red Pixels DATA	Input	
6	R2	Red Pixels DATA	Input	
7	R3	Red Pixels DATA	Input	
8	R4	Red Pixels DATA	Input	
9	R5	Red Pixels DATA (MSB)	Input	
10	G0	Green Pixels DATA(LSB)	Input	
11	G1	Green Pixels DATA	Input	
12	G2	Green Pixels DATA	Input	
13	G3	Green Pixels DATA	Input	
14	G4	Green Pixels DATA	Input	
15	G5	Green Pixels DATA(MSB)	Input	
16	V0	Gray Scale Correction Voltage	Input	
17	V1	Gray Scale Correction Voltage	Input	
18	V2	Gray Scale Correction Voltage	Input	
19	V3	Gray Scale Correction Voltage	Input	
20	V4	Gray Scale Correction Voltage	Input	
21	V5	Gray Scale Correction Voltage	Input	
22	V6	Gray Scale Correction Voltage	Input	
23	V7	Gray Scale Correction Voltage	Input	
24	V8	Gray Scale Correction Voltage	Input	
25	V9	Gray Scale Correction Voltage	Input	
26	V10	Gray Scale Correction Voltage	Input	
27	DVDD	Power Supply (+3.3V)	Input	for Source Driver logic voltage
28	LOAD	Source Driver Data Load pulse	Input	
29	STH2(DO/I)	Horizontal start pulse (Reverse)	Input	L/R="H";Open, L/R="L";STH Signal Input
30	L/R	Horizontal Reverse Select Signal	Input	"H"Level=Normal, "L"Level=Reverse
31	CPH	Horizontal sampling clock	Input	for Source Driver
32	B0	Blue Pixels DATA(LSB)	Input	
33	B1	Blue Pixels DATA	Input	
34	B2	Blue Pixels DATA	Input	
35	B3	Blue Pixels DATA	Input	
36	B4	Blue Pixels DATA	Input	
37	B5	Blue Pixels DATA(LSB)	Input	
38	VSS	GND	-	
39	VSS	GND	-	
40	Vcom	Common Voltage	Input	
41	Vcom	Common Voltage	Input	
42	STV2	Vertical start pulse (Reverse)	Input	U/D="L";Open, U/L="H";STV Signal Input
43	GVDD(VCC)	Power Supply (VGL+3.3V)	Input	for Gate Driver logic voltage
44	VSS	GND	-	
45	U/D	Vertical Reverse Select Signal	Input	"L"Level=Normal, "H"Level=Reverse
46	CPV	Vertical shift clock	Input	for Gate Driver
47	DVDD	Power Supply (+3.3V)	Input	for Source Driver logic voltage
48	VGL(VVEE)	Power Supply(-12V)	Input	for LCD gate voltage(low)
49	VGH(VGG)	Power Supply(+15V)	Input	for LCD gate voltage(high)
50	STV1	Vertical start pulse (Normal)	Input	U/D="L";STV Signal Input, U/L="H";Open

**CN2 CCFL POWER SOURCE**

Connector : JST/BHSR-02VS-01

Mating Connector : JST/SM02B-BHS-1

Terminal No.	Symbol	Function
1	VFLH	CCFL POWER SUPPLY (HIGH VOLTAGE)
2	VFLL	CCFL POWER SUPPLY (LOW VOLTAGE)

Note 1) NC Terminal is open. (Don't use)

Note 2) See next page.

256k (k=1024) COLORS COMBINATION TABLE

	Display	R5 R4 R3 R2 R1 R0	G5 G4 G3 G2 G1 G0	B5 B4 B3 B2 B1 B0	Gray Scale Level
Basic Color	Black	L L L L L L L	L L L L L L L	L L L L L L L	-
	Blue	L L L L L L L	L L L L L L L	H H H H H H H	-
	Green	L L L L L L L	H H H H H H H	L L L L L L L	-
	Light Blue	L L L L L L L	H H H H H H H	H H H H H H H	-
	Red	H H H H H H H	L L L L L L L	L L L L L L L	-
	Purple	H H H H H H H	L L L L L L L	H H H H H H H	-
	Yellow	H H H H H H H	H H H H H H H	L L L L L L L	-
White	H H H H H H H	H H H H H H H	H H H H H H H	-	
Gray Scale of Red	Black	L L L L L L L	L L L L L L L	L L L L L L L	L 0
	Dark ↑ ↓ Light	L L L L L L H	L L L L L L L	L L L L L L L	L 1
		L L L L L H L	L L L L L L L	L L L L L L L	L 2
		: : :	: : :	: : :	L3... L60
		H H H H L H L	L L L L L L L	L L L L L L L	L61
		H H H H H L L	L L L L L L L	L L L L L L L	L62
	Red	H H H H H H H	L L L L L L L	L L L L L L L	Red L63
Gray Scale of Green	Black	L L L L L L L	L L L L L L L	L L L L L L L	L 0
	Dark ↑ ↓ Light	L L L L L L L	L L L L L L H	L L L L L L L	L 1
		L L L L L L L	L L L L L H L	L L L L L L L	L 2
		: : :	: : :	: : :	L3... L60
		L L L L L L L	H H H H L H L	L L L L L L L	L61
		L L L L L L L	H H H H H L L	L L L L L L L	L62
	Green	L L L L L L L	H H H H H H H	L L L L L L L	Green L63
Gray Scale of Blue	Black	L L L L L L L	L L L L L L L	L L L L L L L	L 0
	Dark ↑ ↓ Light	L L L L L L L	L L L L L L L	L L L L L L H	L 1
		L L L L L L L	L L L L L L L	L L L L H L L	L 2
		: : :	: : :	: : :	L3... L60
		L L L L L L L	L L L L L L L	H H H H L H L	L61
		L L L L L L L	L L L L L L L	H H H H H L L	L62
	Blue	L L L L L L L	L L L L L L L	H H H H H H H	Blue L63
Gray Scale of White & Black	Black	L L L L L L L	L L L L L L L	L L L L L L L	L 0
	Dark ↑ ↓ Light	L L L L L L H	L L L L L L H	L L L L L L H	L 1
		L L L L L H L	L L L L L H L	L L L L L H L	L 2
		: : :	: : :	: : :	L3... L60
		H H H H L H L	H H H H L H L	H H H H L H L	L61
		H H H H H L L	H H H H H L L	H H H H H L L	L62
	White	H H H H H H H	H H H H H H H	H H H H H H H	White L63

**FOR SAFETY**

LCD module is generally designed with precise parts to achieve light weighted thin mechanical dimensions.

In using our Modules, make certain that you fully understand and put into practice the warnings and safety precautions detailed in Engineering Information No.EE-N001,"CAUTIONS AND INSTRUCTIONS FOR TOSHIBA MATSUSHITA DISPLAY TECHNOLOGY CO.,LTD. LCD MODULES".

Refer to individual specifications and TECHNICAL DATA sheets (hereinafter called "TD") for more detailed technical information.

**1) SPECIAL PURPOSES**

A) Toshiba Matsushita Display Technology Co.,Ltd.'s Standard LCD Modules have not been customized for operation in extreme environments or for use in applications where performance failures could be life-threatening or otherwise catastrophic.

B) Since Toshiba Matsushita Display Technology Co.,Ltd.'s Standard LCD Modules have not been designed for operation in extreme environments, they must never be used in devices that will be exposed to abnormally high levels of vibration or shock which exceed Toshiba Matsushita Display Technology Co.,Ltd.'s published specification limits.

C) In addition, since Toshiba Matsushita Display Technology Co.,Ltd.'s Standard LCD Modules have not been designed for use in applications where performance failures could be life-threatening or catastrophic, they must never be installed in aircraft navigation control systems (such as, but not limited to Traffic Collision Avoidance System and Air Traffic Indicator), in military defense or weapons systems, in critical industrial process-control systems (e.g., those involved in the production of nuclear energy), or in critical medical device or patient life-support systems.

**2) DISASSEMBLING OR MODIFICATION**

DO NOT DISASSEMBLE OR MODIFY the module. It may damage sensitive parts inside LCD module, and may cause scratches or dust on the display.

Toshiba Matsushita Display Technology Co.,Ltd. does not warrant the module, if customer disassembled or modified it.

**3) BREAKAGE OF LCD PANEL**

DO NOT INGEST liquid crystal material, DO NOT INHALE this material, and DO NOT CONTACT the material with skin, if LCD panel is broken and liquid crystal material spills out.

If liquid crystal material comes into mouth or eyes, rinse mouth or eyes out with water immediately.

If this material contact with skin or cloths, wash it off immediately with alcohol and rinse thoroughly with water.

**4) GLASS OF LCD PANEL**

BE CAREFUL WITH CHIPS OF GLASS that may cause injuring fingers or skin, when the glass is broken.

**5) ELECTRIC SHOCK**

DISCONNECT POWER SUPPLY before handling LCD module.

DO NOT TOUCH the parts inside LCD module and the fluorescent lamp's connector or cables in order to prevent electric shock, because high voltage is supplied to these parts from the inverter unit while power supply is turned on.

**6) ABSOLUTE MAXIMUM RATINGS AND POWER PROTECTION CIRCUIT**

DO NOT EXCEED the absolute maximum rating values under the worst probable conditions caused by the supply voltage variation, input voltage variation, variation in parts' constants, environmental temperature, etc., otherwise LCD module may be damaged.

Employ protection circuit for power supply, whenever the specification or TD specifies it.

Suitable protection circuit should be applied for each system design.

**7) DISPOSAL**

When dispose LCD module, obey to the applicable environmental regulations.