

To: INVENTEC ELECTRONICS (NANJING) CO., LTD

APPROVAL SIGNATURE

SPECIFICATION (DRAFT)

FOR

Toshiba Matsushita Display Technology TFT-LCD MODULE

LTM024P339

SPECIFICATION No. : _____
NL-LTM024P339-06

DATE OF ISSUE 2003-06-09

(DATE OF EXPIRY : 2006-10-30)

Mobile-Use Marketing & Engineering Dept.
Mobile-Use LCD Div.
Toshiba Matsushita Display Technology Co.,Ltd.
1-9-2, Hatara-cho, Fukaya-shi, Saitama, 366-0032, JAPAN

Revision History

Date	Sheet (New)	Item	Old	New	Reason
2002-10-30	20	Reference Drive Circuit			Change
	21	List of External Components for Reference Driving Circuit			Addition
	22,23	Timing Chart (For LCD controller settings)			Addition
2003-05-29	23	Timing Chart (For LCD controller settings)			Decision
	21	List of External Components for Reference Driving Circuit	C316 ; 330uF/6.3V VR300 ; 200	C316 ; 330pF/6.3V VR300 ; 200K	Change the best value
2003-06-09	09	Dimensional Outline		(a)-(b)= Less than +/-0.5[mm]	Addition
	16	Interface Terminal		1)LCD-FPC z direction size =0.12+/-0.05[mm], 2)T/P-FPC z direction size =0.2+/-0.05[mm], 3)LED-FPC z direction size =0.2+/-0.05[mm]	Addition
	19	Touch Panel's characteristics		1)Resistance X/Y direction ; X=650+/-300[ohm] , Y=600+/-300[ohm] 2)The variation with temperature ; Less than 0.5%/°C 3)Flatness=Less than +/- 0.15[mm]	Addition
	25	Quality		Inspection area should be within viewing area.	Change
	26	Display Quality(LCD)		IAC and TMD will discuss it when inconspicuous defect(flicker, crosstalk, Newton ring etc)happen.	Addition

Caution and Handling Precaution

For your end user's safety, it is strongly advised that the items with " * " should be included in the instruction manual of the system which may be issued by your organization.

For Safety



Warning

- (1) Toshiba matsushita display technology co.,ltd.'s Standard LCD modules have not been customized for operation in extreme environments or for use in applications where performance failures could be life-threatening or otherwise catastrophic.
Since they must never be installed in aircraft navigation control systems (such as, but not limited to Traffic Collision System and Air traffic Indicator), in military defense or weapons systems, in critical industrial process-control systems (e.g., those involved in the production of nuclear energy), or in critical medical device or patient life-support systems.
- (2) DISCONNECT POWER SUPPLY before handling LCD module.
DO NOT TOUCH the parts inside LCD module in order to prevent electric shock, because high voltage is supplied to these parts from the inverter unit while power supply is turned on.



Caution

- (1) DO NOT DISASSEMBLE OR MODIFY the module.
Sensitive parts inside LCD module may be damaged, and dusts or scratches may mar the displays.
Toshiba matsushita display technology co.,ltd. does not warrant the modules, if customer disassembled or modified them.
- * (2) DO NOT INGEST liquid crystal material, DO NOT INHALE this material, and DO NOT PERMIT this material to contact the skin, if LCD panel is broken and liquid crystal material spills out.
In the event of inadvertent contact, immediately rinse the mouth or eyes with adequate water. If this material should inadvertently contact the skin or clothing, wash immediately with alcohol and then rinse thoroughly with water.
- * (3) BE CAREFUL WITH CHIPS OF GLASS that may cause injuring fingers or skin, when the glass is broken.
- (4) DO NOT EXCEED the absolute maximum rating values under the worst probable conditions caused by the supply voltage variation, input voltage variation, variation in parts' constants, ambient temperature, etc., otherwise LCD module may be damaged.
- (5) Suitable protection circuit should be applied for each system design.
It may cause overheat and/or burning if dusts or metal particles are on the PCBs in the LCD module.
- (6) Examine the power supply circuit protective device at the time of the LCD module failure according to the operation condition of your set. This LCD module has not any fuse.
Therefore, the case where there is no suitable power supply protection equipment, it is possible that the circuit of LCD module or your set is damaged by Over-current at the time of failure of a circuit.
- (7) Always comply with all applicable environmental regulations, when disposing of LCD.

For Designing the System

- (1) Make sure to design the enclosure that bending/twisting forces are not applied to LCD module during and after the installation into the system.
Make certain clearance between LCD module and system for not press I/F cable, FPC and pipe light guide etc..
- (2) Power supply lines should be designed as follows.
Power(DVDD) supplies should always be turned on before the input signals are supplied to LCD module, and the input signals should be disconnected before power supplies are turned off.
If the sequence does not satisfy specified conditions, it may cause miss-operation of the panel.
Refer to "2.4.2 Sequence of Power Supplies and Signals" for the detailed specification.
- (3) In case of severe environmental condition like outdoor usage, a proper transparent protective cover(lens) over LCD module is recommended to apply in order to prevent scratches, and invasion of dust, water, etc., from the system's window onto LCD module.
Ultra-violet ray cut filter is recommended to apply onto LCD module for outdoor operation. Strong ultra-violet ray may cause damage the panel.
- (4) Design the system not to display same pattern for a long time in order to prevent image sticking on the panel. Note that incorrect sequence of power supplies and input signals may cause the sticking on the panel, too.

For Installation in Assembly

- (1) The C-MOS LSIs (COG; Chip on glass) used in LCD module are very sensitive to ESD (Electro-static Discharge). Ambient humidity of working area is recommended to be higher than 50%(RH).
Person handling LCD modules should be grounded with wrist band. Tools like soldering iron and screw driver, and working benches should be grounded.
The grounding should be done through a resistor of 0.5-1MΩ in order to prevent spark of ESD.
- (2) When remove protection film from LCD panel, peel off the film slowly (more than three seconds) from the edge of the panel, using a soft-pointed tweezers covered by teflon or adherent tape.
- (3) Reduce dust level in working area. Especially the level of metal particle should be decreased.
Use finger stalls or soft and dust-free gloves in order to keep clean appearance of LCD module when handled for incoming inspection and assembly.
- (4) When LCD panel becomes dirty, wipe off the panel surface softly with absorbent cotton or another soft cloth.
If the dirt can not be wiped off, absorbent cotton wetted a little with alcohol can be used for wiping the panel.
Be careful not to spill this solvent into the inside of LCD module. Driver Ics and PCB area used inside LCD module may be damaged by the solvent.
- (5) AVOID THE CONDENSATION OF WATER
Wipe off a spot or spots of water or mist and chemicals of mist on LCD panel softly with absorbent cotton or another cloth as soon as possible if happened, otherwise discoloration or stain may be caused. If water invade into LCD module, it may cause LCD module damages.
- (6) Do not expose LCD module to the gas (which is not normally contained in the atmosphere), it may cause mis-operation or defects.
- (7) DO NOT APPLY MECHANICAL FORCES.
Do not bend or twist LCD module even momentary when LCD module is installed an enclosure of the system. Bending or twisting LCD module may cause its damages.
Make sure to design the enclosure that bending/twisting forces are not applied to LCD module when it is installed in the system.
Refrain from strong mechanical shock like dropping from the working bench or knocking against hard object.
These may cause glass of the panel crack, damage of FL or other mis-operation.
- (8) Refrain from excessive force like pushing the surface of LCD panel. This may cause damage of the panel or electrical parts.
- (9) Do not put heavy object such as tools, books, etc., and do not pile up LCD modules.
Be careful not to touch surface of the lightguide with any hard and sharp object. The lightguide is so soft that it can easily scratched, even the protect film covers it.
- (10) When inserting or disconnecting the connectors to LCD module, be sure not to apply force against FPC, otherwise internal connection of Glass and FPC may be damaged.
Do not fasten screws while putting cables like those for interface or FL between LCD module and the enclosure.
Make sure to insert the module FL connector to the inverter connector in correct position.
If incorrect, this may cause smoke or burn of electrical parts by high voltage of FL circuit.
- (11) Be careful not to pull the frontlight FL cables of the backlight in order to avoid mechanical damage in FL lamp and soldering area. Be careful not to pull or not to hurt the FPC (Flexible Printed Circuit) cables.
- (12) Power supplies should always be turned off in assembling process.
Do not connect or disconnect the power cables and connectors with power applied to LCD module. This may cause damage of module circuit.
The signal should be applied after power are turned on. And the signal should be removed before power supplies are turned off. (Refer to "For Designing The System"(2)).

- (13) The life of CCFL becomes shorter than MTBF indicated by the specifications when ambient temperature is lower than 25°C. (It even reaches to 1/10 to 1/20 in 0 °C.)

For Transportation and Storage

- (1) Do not store LCD module in high temperature, especially in high humidity for a long time (approximately more than one month).
It is recommended to store LCD module where the temperature is in the range of 0 to 35 °C and the relative humidity is lower than 70%.
- (2) Store LCD module without exposure to direct sunlight or fluorescent lamps in order to prevent the module from strong ultra violet ray.
- (3) Avoid condensation of water on LCD module, otherwise it may cause mis-operation or defects. Keep away LCD module from such ambient.
- (4) In case of transportation of storage after opening the original packing. LCD module are recommended to be repacked into the original packaging with the same method, especially with same kind of desiccant.

- CONTENTS -

Revision History	Sheet 1
Caution and Handling Precaution	2
1. Scope	7
2. Product Specifications	7
2.1 General Specifications		
2.2 Absolute Maximum Ratings	8
2.3 Mechanical Specifications	9
2.3.1 Weight		
2.3.2 Dimensional Outline		
2.4 Electrical Specifications	10
2.4.1 Circuit Diagram		
2.4.2 Sequence of Power Supplies and Signals	11
2.4.3 Timing Chart	12
2.4.4 Interface Connector	16
2.4.5 Colors Combination Table	17
3. Recommended Operating Conditions	18
4. Electrical Characteristics	19
4.1 Test Conditions	19
4.2 Specifications		
4.3 Reference Drive Circuit	20
4.4 List of External Components for Reference Driving Circuit	21
4.5 Timing (For LCD controller settings)	22
5. Optical Characteristics	24
5.1 Test Conditions		
5.2 Optical Specifications		
6. Quality	25
6.1 Test Conditions		
6.2 Dimensional Outline		
6.3 Appearance Test	25
6.3.1 Test Conditions		
6.3.2 Specifications		
6.4 Display Quality	26
6.4.1 Test Conditions		
6.4.2 Specifications		
6.5 Reliability Test	27
6.5.1 Test Conditions		
6.5.2 Specifications		
6.6 Labels	28
7. Packaging	29
8. Warranty	30
9. Regulation	30
10. Measuring Method	30
10.1 Measuring Systems		
10.2 Measuring Methods	32

1. Scope

This specification is applicable to Toshiba Matsushita Display Technology Co., Ltd.'s 6.18cm(2.4") diagonal size TFT-LCD module "LTM024P339" designed for mobile phone equipment.

2. Product Specifications

2.1 General Specifications

Item	Specifications
Display Mode	TN color(16 gray scales, 4096 colors) Reflective type, Normally white
Viewing Direction	(6 o'clock) (in direction of maximum contrast)
Driving Method	TFT active matrix
Input Signals	Power Supply; YVDD, YGVSS, YGVDD, CS, XVDD, COM Control Signals ;YST, /YST, YCK, /YCK, YSHUT, /YSHUT, XSWST, /XSWST, XCK, /XCK, XST, /XST, REF1, /REF1, DMA0, V5N, V9N, GMA5B, GMA5A, V9P, V5P, GMA10 Data Signals; DA[3:0], /DA[3:0], DB[3:0], /DB[3:0], DC[3:0], /DC[3:0], DD[3:0], /DD[3:0],
Active Area	37.08 (W) × 49.44 (H) (mm)
Viewing Area	39.08 (W) × 51.44 (H) (mm)
Response Area for Touch Panel	38.75 (W) × 51.14 (H) (mm)
Number of Pixels	240(xRGB) (W) × 320 (H) ¹⁾
Pixel Pitch	0.1545 (W) × 0.1545 (H) (mm) ¹⁾
Pixel Arrangement	RGB vertical stripes ¹⁾
Surface Treatment for Touch Panel	3H
Front Light	2 LEDS
Dimensional Outline	46.8 (W) × 70.4 (H) × 4.5 (D) (mm)

Note 1)

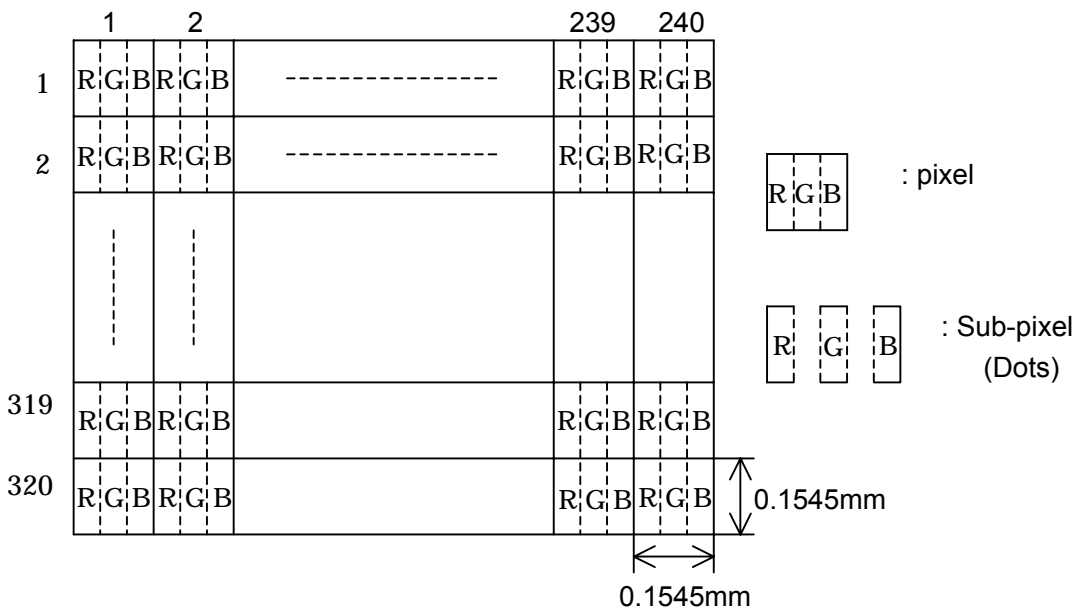

2.2 Absolute Maximum Ratings ¹⁾

Item	Symbol	Min.	Max.	Unit	Checked Terminal
Supply Voltage	VI_2	-2.5	5.0	V	YGVSS
	VI_3	-0.5	10.5	V	XCK,XST, XSWST,YST,YCK,YSHUT,D** ³⁾ REF1
	VI_5	-0.5	10.5	V	COM
	VI_10	-0.5	10.5	V	YVDD, XVDD
	VI_15	-0.5	15.75	V	YGVDD, CS
Supply Voltage for Touch Panel	V _{IT}	0	7	V	
Operating Ambient Temperature ²⁾	T _{OP}	0	50	°C	
Operating Ambient Humidity ²⁾	H _{OP}	10	90	%(RH)	
Storage Temperature ²⁾	T _{STG}	-25	+70	°C	
Storage Humidity ²⁾	H _{STG}	10	90	%(RH)	

Note 1) Do not exceed the maximum rating values under the worst probable conditions taking into account the supply voltage variation, input voltage variation, variation in part constants, and ambient temperature and so on. Otherwise the module may be damaged.

2) Wet bulb temperature should be 39°C Max, and no condensation of water. See figure below.

3) D** means D[3:0] , /D[3:0]

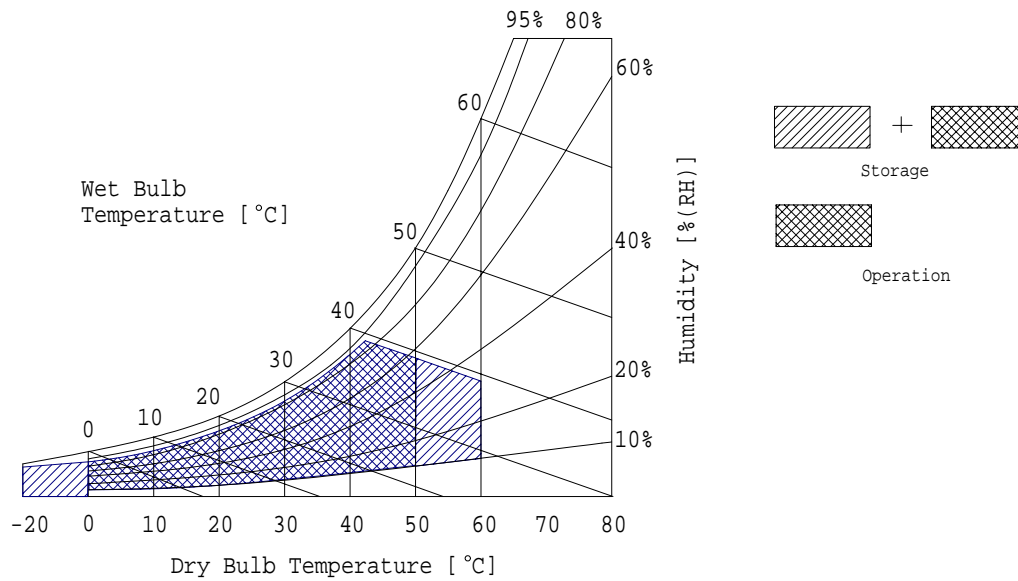

2.3 Mechanical Specifications

2.3.1 Weight

2.4g ± 3g

2.3.2 Dimensional Outline

Unit: mm

Standard Tolerance: ± 0.3

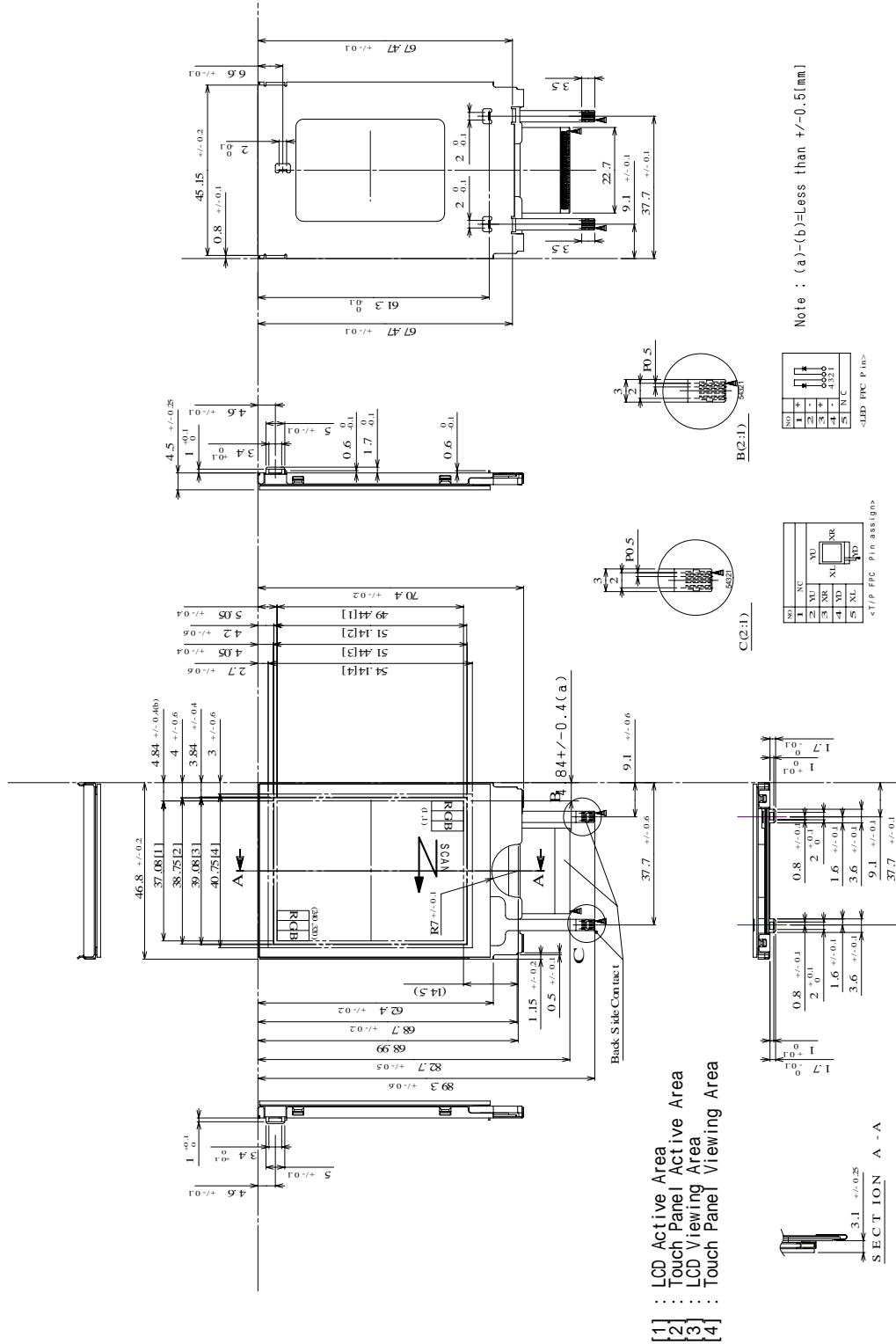

2.4 Electrical Specifications

2.4.1 Circuit Diagram

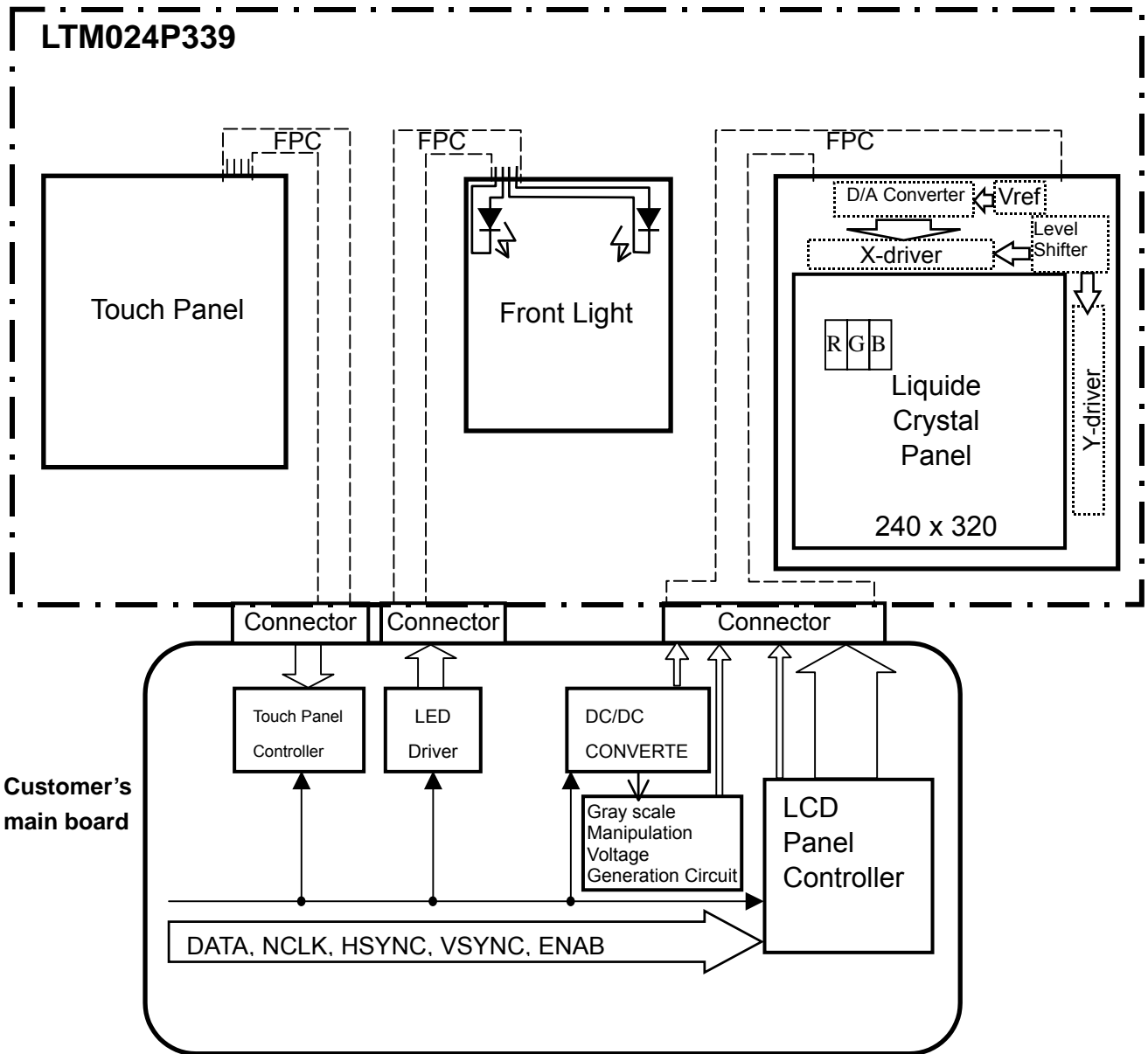

2.4.2 Sequence of Power Supplies and Signals

Turn on the power and signal supply sequence is as follows.

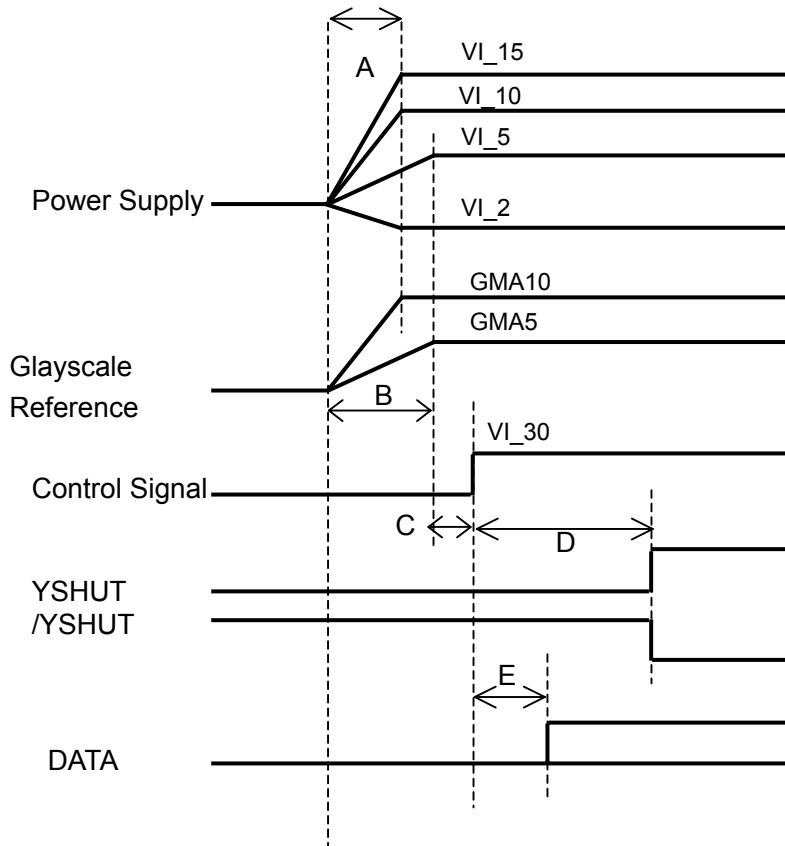

Item	Symbol	Signal	Min	Max	unit
A	VI_15	YGVDD,CS	0	30	ms
A	VI_10	YVDD, XVDD,GMA10	0	30	ms
A	VI_2	YGVSS	0	30	ms
A	---	GMA10	0	30	ms
B	VI_5	COM	---	30	ms
B	---	GMA5	---	30	ms
C	---	XCK,XST,XSWST,YCK,YST,YSWST	0	22.22 ¹⁾	ms
D	---	YSHUT	0	22.22 ¹⁾	ms
E	---	DATA	0	22.22 ¹⁾	ms

Note 1) Frame period.

2.4.3 AC Timing Chart for LCD Module

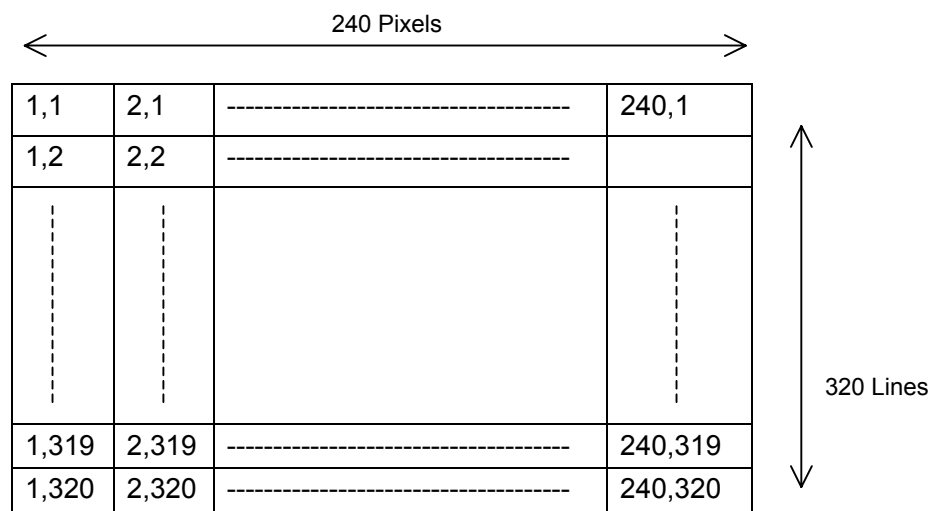
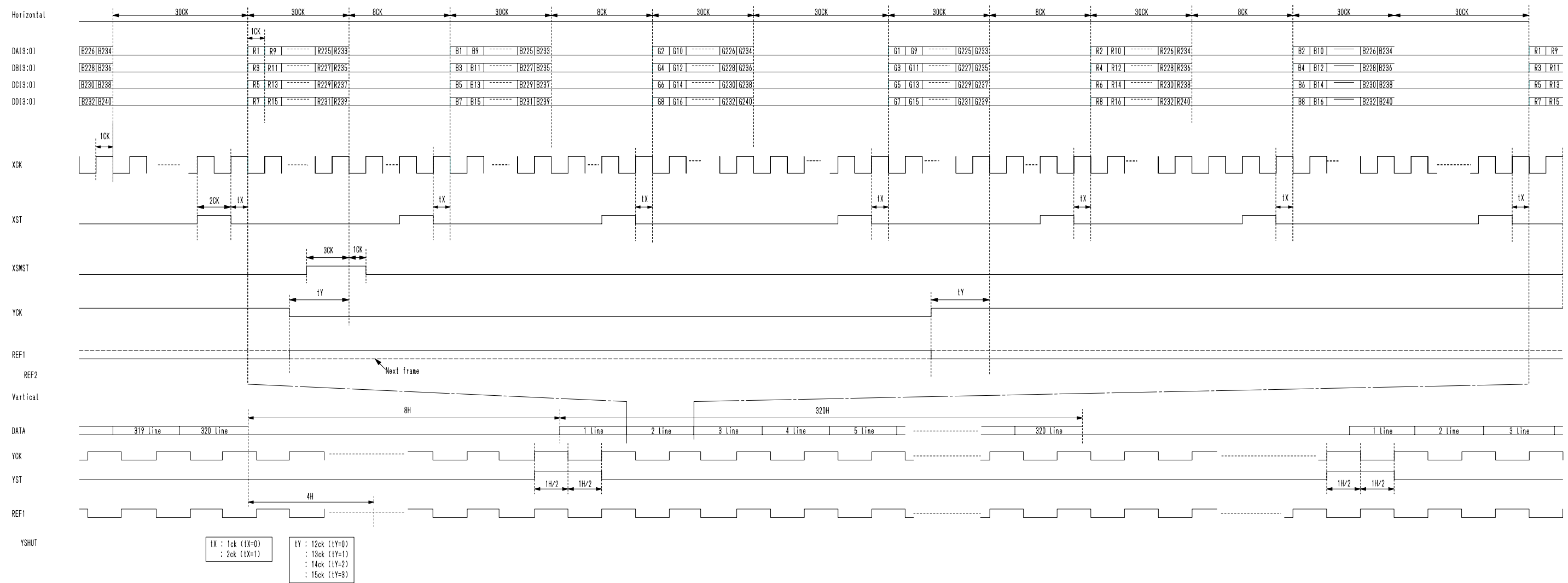

2.4.4 AC Timing for LCD Module

PIN	Item	symbol	Min.	Max.	unit
XST	rising time	tTLH	-	40	ns
	falling time	tTHL	-	40	ns
	XST rise => /XST fall time	tDLH	-15	15	ns
	XST fall => /XST rise time	tDHL	-15	15	ns
XCK	rising time	tTLH	-	40	ns
	falling time	tTHL	-	40	ns
	XCK rise => /XCK fall time	tDLH	-15	15	ns
	XCK fall => /XCK rise time	tDHL	-15	15	ns
DATA ¹⁾	rising time	tTLH	-	40	ns
	falling time	tTHL	-	40	ns
	D** rise => /D** fall time	tDLH	-15	15	ns
	D** fall => /D** rise time	tDHL	-15	15	ns
XSWST	rising time	tTLH	-	40	ns
	falling time	tTHL	-	40	ns
	XSWST rise => /XSWST fall time	tDLH	-15	15	ns
	XSWST fall => /XSWST rise time	tDHL	-15	15	ns
YST	rising time	tTLH	-	40	ns
	falling time	tTHL	-	40	ns
	YST rise => /YST fall time	tDLH	-15	15	ns
	YST fall => /YST rise time	tDHL	-15	15	ns
YCK	rising time	tTLH	-	40	ns
	falling time	tTHL	-	40	ns
	YCK rise => /YCK fall time	tDLH	-15	15	ns
	YCK fall => /YCK rise time	tDHL	-15	15	ns
DATA-CLK	XCK => DATA timing	tD_CK	-20	15	ns
	/XCK => /DATA timing	tD_CK	-20	15	ns
XST/XCK	XST setup time	tXSTsu	100	-	ns
	XST hold time	tXSThd	100	-	ns
YST/YCK	YSTU setup time	tYSTsu	1	-	μs
	YSTU hold time	tYSThd	1	-	μs
Note1) D** means DA[3:0],DB[3:0],DC[3:0],DD[3:0]					

PIN	Item	Symbol	Wave Form
XST	rising time	t _{TLH}	
	falling time	t _{THL}	
	XST rise => /XST fall time	t _{DLH}	
	XST fall => /XST rise time	t _{DHL}	
XCK	rising time	t _{TLH}	
	falling time	t _{THL}	
	XCK rise => /XCK fall time	t _{DLH}	
	XCK fall => /XCK rise time	t _{DHL}	
DATA ²⁾	rising time	t _{TLH}	
	falling time	t _{THL}	
	D** rise => /D** fall time	t _{DLH}	
	D** fall => /D** rise time	t _{DHL}	
XSWST	rising time	t _{TLH}	
	falling time	t _{THL}	
	XSWST rise => /XSWST fall time	t _{DLH}	
	XSWST fall => /XSWST rise time	t _{DHL}	

PIN	Item	Symbol	Wave Form
YST	rising time	tTLH	
	falling time	tTHL	
YCK	rising time	tTLH	
	falling time	tTHL	
DATA XCLK	timing between XCK and DATA	tD_CK (minus)	
		tD_CK (plus)	
XST XCK	XST/XCK setup/hold time	tXSTsu tXSThd	
YST YCK	YST/YCK setup/hold time	tYSTsu tYSThd	

2.4.4 Interface Terminal

FPC : 0.3mm pitch 70pins, z direction size 0.12+/-0.05[mm]

Mating Connector : FF0270SA1 (JAE)

Pin No.	Symbol	Connect to		Pin No.	Symbol	Connect to			
		Pin No.	Symbol			Pin No.	Symbol		
1	COM	Pow IC	2	COM	36	DB1	LCDC	82	DB1
2	/YST	LCDC	43	/YST	37	/DB2	LCDC	77	/DB2
3	YST	LCDC	44	YST	38	DB2	LCDC	78	DB2
4	/YCK	LCDC	46	/YCK	39	/DB3	LCDC	75	/DB3
5	YCK	LCDC	47	YCK	40	DB3	LCDC	76	DB3
6	YSHUT	LCDC	49	YSHUT	41	/DA0	LCDC	95	/DA0
7	/YSHUT	LCDC	48	/YSHUT	42	DA0	LCDC	96	DA0
8	YVDD	Pow IC	12	Ch3	43	/DA1	LCDC	93	/DA1
9	YVSS	GND	-	-	44	DA1	LCDC	94	DA1
10	YGVSS	Pow IC	34	Ch5	45	/DA2	LCDC	90	/DA2
11	YGVDD	Pow IC	13	Ch4	46	DA2	LCDC	92	DA2
12	CS	Pow IC	13	Ch4	47	/DA3	LCDC	86	/DA3
13	XSWST	LCDC	97	XSWST	48	DA3	LCDC	87	DA3
14	/XSWST	LCDC	98	/XSWST	49	XVSS	GND	-	-
15	XVDD	Pow IC	12	Ch3	50	XVDD	Pow IC	12	Ch3
16	XVSS	GND	-	-	51	/XCK	LCDC	103	/XCK
17	/DD0	LCDC	61	/DD0	52	XCK	LCDC	102	XCK
18	DD0	LCDC	62	DD0	53	/XST	LCDC	100	/XST
19	/DD1	LCDC	59	/DD1	54	XST	LCDC	99	XST
20	DD1	LCDC	60	DD1	55	GMA0	-	-	-
21	/DD2	LCDC	57	/DD2	56	V5N	-	-	-
22	DD2	LCDC	58	DD2	57	V9N	-	-	-
23	/DD3	LCDC	54	/DD3	58	GMA5B	-	-	-
24	DD3	LCDC	56	DD3	59	GMA5A	-	-	-
25	/DC0	LCDC	72	/DC0	60	V9P	-	-	-
26	DC0	LCDC	74	DC0	61	V5P	-	-	-
27	/DC1	LCDC	70	/DC1	62	GMA10	-	-	-
28	DC1	LCDC	71	DC1	63	REF1	LCDC	41	REF1
29	/DC2	LCDC	68	/DC2	64	/REF1	LCDC	42	/REF1
30	DC2	LCDC	69	DC2	65	XVSS	GND	-	-
31	/DC3	LCDC	66	/DC3	66	XVDD	Pow IC	12	Ch3
32	DC3	LCDC	67	DC3	67	CS	Pow IC	13	Ch4
33	/DB0	LCDC	84	/DB0	68	YGVDD	Pow IC	13	Ch4
34	DB0	LCDC	85	DB0	69	YGVSS	Pow IC	34	Ch5
35	/DB1	LCDC	81	/DB1	70	COM	Pow IC	2	COM

<Touch Panel I/F>

FPC : 0.5mm pitch 5pins, z direction size 0.2+/-0.05[mm]

Mating Connector : 04 6249 005 000 800 (KYOCERA ELCO)

<Front Light I/F>

FPC : 0.5mm pitch 5pins, z direction size 0.2+/-0.05[mm]

Mating Connector : 04 6249 005 000 800 (KYOCERA ELCO)

Touch Panel

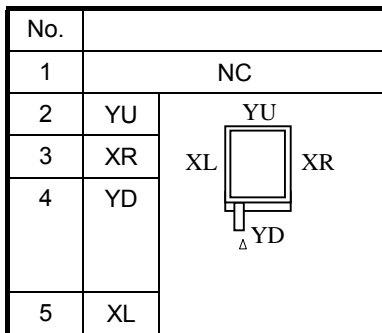

Front Light

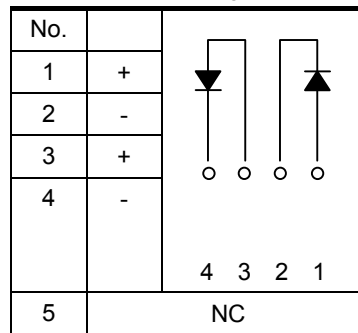

2.4.5 Colors Combination Table

	Display	R3	R2	R1	G3	G2	G1	B3	B2	B1	Gray Scale Level		
Basic Color	Black	L	L	L	L	L	L	L	L	L	-		
	Blue	L	L	L	L	L	L	H	H	H	-		
	Green	L	L	L	L	H	H	H	L	L	-		
	Light Blue	L	L	L	L	H	H	H	H	H	-		
	Red	H	H	H	H	L	L	L	L	L	-		
	Purple	H	H	H	H	L	L	L	H	H	-		
	Yellow	H	H	H	H	H	H	H	L	L	-		
	White	H	H	H	H	H	H	H	H	H	-		
Gray Scale of Red	Black	L	L	L	L	L	L	L	L	L	L 0		
	Dark	L	L	L	H	L	L	L	L	L	L	L 1	
		L	L	H	L	L	L	L	L	L	L	L 2	
		:	:	:	:	:	:	:	:	:	:	L3¼	
		:	:	:	:	:	:	:	:	:	:	L12	
	Light	H	H	L	H	L	L	L	L	L	L	L13	
		H	H	H	L	L	L	L	L	L	L	L14	
	Red	H	H	H	H	L	L	L	L	L	L	Red L15	
Gray Scale of Green	Black	L	L	L	L	L	L	L	L	L	L 0		
	Dark	L	L	L	L	L	L	L	H	L	L	L 1	
		L	L	L	L	L	L	H	L	L	L	L 2	
		:	:	:	:	:	:	:	:	:	:	L3¼	
		:	:	:	:	:	:	:	:	:	:	L12	
	Light	L	L	L	L	H	H	L	H	L	L	L13	
		L	L	L	L	H	H	H	L	L	L	L14	
	Green	L	L	L	L	H	H	H	H	L	L	Green L15	
Gray Scale of Blue	Black	L	L	L	L	L	L	L	L	L	L 0		
	Dark	L	L	L	L	L	L	L	L	L	H	L 1	
		L	L	L	L	L	L	L	L	L	H	L 2	
		:	:	:	:	:	:	:	:	:	:	L3¼	
		:	:	:	:	:	:	:	:	:	:	L12	
	Light	L	L	L	L	L	L	L	H	H	L	H	L13
		L	L	L	L	L	L	L	H	H	H	L	L14
	Blue	L	L	L	L	L	L	L	H	H	H	H	Blue L15
Gray Scale of White & Black	Black	L	L	L	L	L	L	L	L	L	L	L 0	
	Dark	L	L	L	H	L	L	L	H	L	L	H	L 1
		L	L	H	L	L	L	H	L	L	H	L	L 2
		:	:	:	:	:	:	:	:	:	:	:	L3¼
		:	:	:	:	:	:	:	:	:	:	:	L12
	Light	H	H	L	H	H	H	L	H	H	L	H	L13
		H	H	H	L	H	H	H	L	H	H	L	L14
	White	H	H	H	H	H	H	H	H	H	H	White L15	

Note1 L: Low level voltage, H: High level voltage

3. Recommended Operating Conditions ¹⁾

Item		Min.	Typ.	Max.	Unit	Remarks
LCD Supply Voltage	VI_2	-2.5	-2.0	-1.5	V	YGVSS
	VI_3	2.7	3.0	3.3	V	XCK,XST, XSWST,YST,YCK,YSHUT, D** ⁵⁾ , REF1
	VI_5	4.75	5.0	5.25	V	COM,GMA5P,GMA5N
	VI_10	9.5	10.0	10.5	V	YVDD, XVDD,GMA10
	VI_15	14.25	15.0	15.75	V	YGVDD, CS
LED Driving Current	(IF)	-	20	20	mA	
Touch Panel Supply Voltage	(VIT)	---	---	7	V	

Note 1) The module should be always operated within these ranges. The "Typ." shows the recommendable value.

4. Electrical Characteristics

4.1 Test Conditions

Ambient Temperature : T_a 25±5°C

Ambient Humidity : H_a 65±20%(RH)

Supply Voltage : Typical Value

Input Signal timing :

Signal Mode	Vertical			Horizontal			NCLK [MHz]	Note
	FV [Hz]	V-TOTAL [Line]	V-DISP [Line]	FH [KHz]	H-TOTAL [NCLK]	ENAB (H-DISP) [NCLK]		
QVGA	45	328	320	14.74	272	240	4.01	

4.2 Specifications ¹⁾

Item	Symbol	Min.	Typ.	Max.	Unit	Remarks
LCD Current Consumption	VI_10	---	3.2	5.4	mA	
	VI_15	---	4.8	30	uA	
	VI_2	---	4.8	30	uA	
LED Current Consumption	I_F	---	20	20	mA	
Power Consumption	LCD ²⁾	---	32	57	mW	@50 cd/m ²
	Frontlight	---	144	160	mW	

Note 1) The Typical value of LCD Current Consumption is measured in the following pattern.

1. White
2. Yellow
3. Purple
4. Red
5. Light Blue
6. Green
7. Blue
8. Black

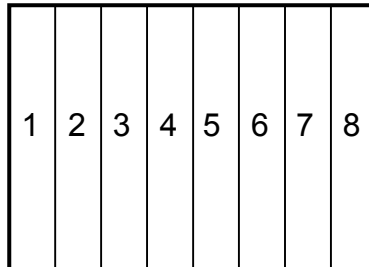

2) without Controller and Power IC

4.3 Touch Panel's characteristics

- 1) Resistance X/Y direction ; X=650+/-300[ohm] , Y=600+/-300[ohm]
- 2) The variation with temperature ; Less than 0.5%/°C
- 3) Flatness=Less than +/- 0.15[mm]

4.3 Reference Driving Circuit

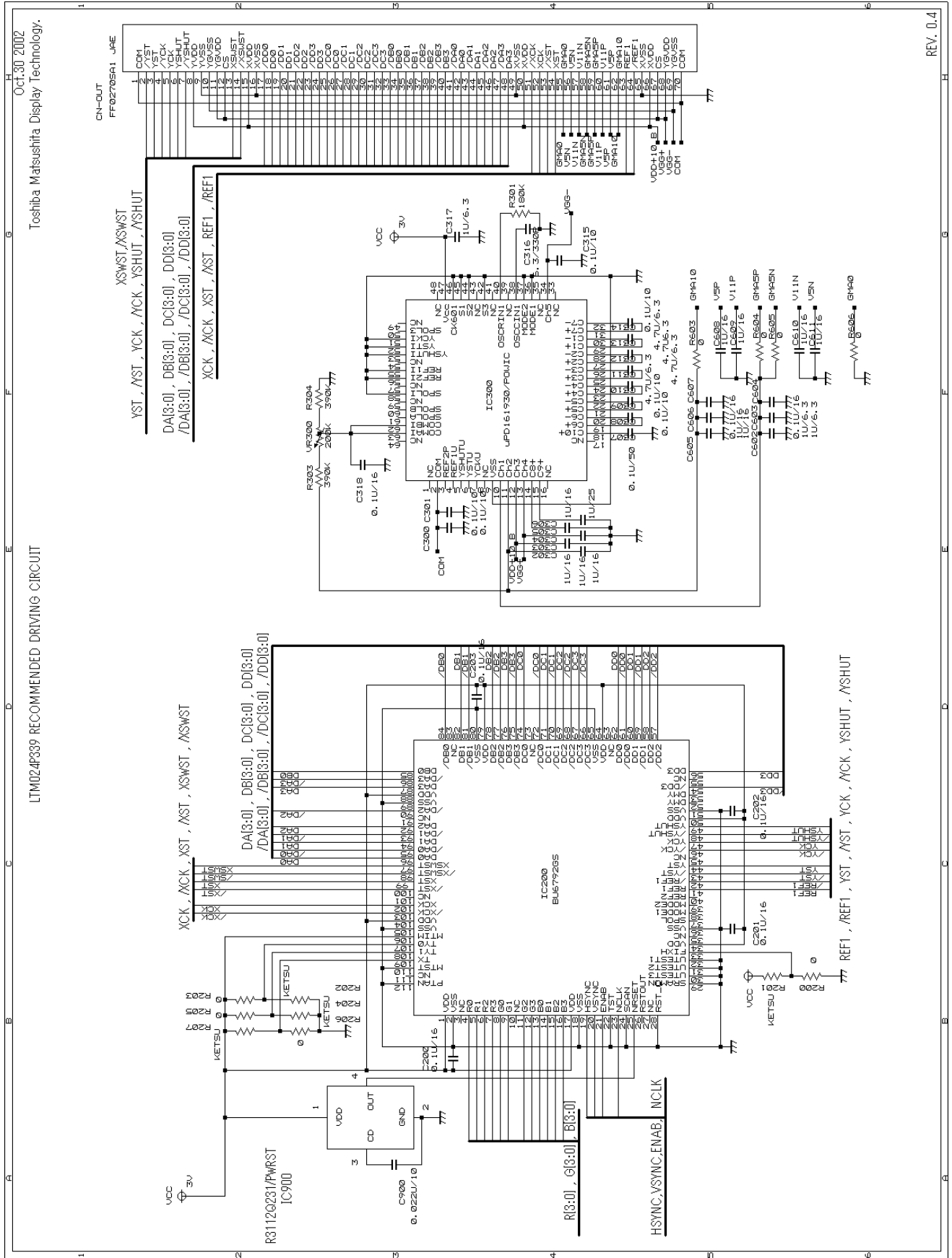

4.4 List of External Components for Reference Driving Circuit

Symbol	Type	Specification	Qty
CN03	Connector	FF0270SA1	1
IC200	LCD Controller	Rohm BU6792GS	1
IC300	Power IC	NEC uPD161930	1
IC900	Detector	Ricoh R3112Q231C	1
C200	Ceramic capacitor	0.1uF/16V/F	1
C201	Ceramic capacitor	0.1uF/16V/F	1
C202	Ceramic capacitor	0.1uF/16V/F	1
C203	Ceramic capacitor	0.1uF/16V/F	1
C300	Ceramic capacitor	0.1uF/10V/B	1
C301	Ceramic capacitor	0.1uF/10V/B	1
C302	Ceramic capacitor	1uF/16V/B	1
C303	Ceramic capacitor	1uF/16V/B	1
C304	Ceramic capacitor	1uF/16V/B	1
C305	Ceramic capacitor	1uF/16V/B	1
C306	Ceramic capacitor	1uF/25V/B	1
C307	Ceramic capacitor	0.1uF/50V/B	1
C308	Ceramic capacitor	0.1uF/10V/B	1
C309	Ceramic capacitor	0.1uF/10V/B	1
C310	Ceramic capacitor	4.7uF/6.3V/B	1
C311	Ceramic capacitor	4.7uF/6.3V/B	1
C312	Ceramic capacitor	4.7uF/6.3V/B	1
C313	Ceramic capacitor	4.7uF/6.3V/B	1
C314	Ceramic capacitor	0.1uF/10V/B	1
C315	Ceramic capacitor	0.1uF/10V/B	1
C316	Ceramic capacitor	330pF/6.3V	1
C317	Ceramic capacitor	1uF/6.3V/B	1
C318	Ceramic capacitor	0.1uF/16V/B	1
C602	Ceramic capacitor	0.1uF/16V/F	1
C603	Ceramic capacitor	1uF/6.3V/B	1
C604	Ceramic capacitor	1uF/6.3V/B	1
C605	Ceramic capacitor	0.1uF/16V/F	1
C606	Ceramic capacitor	1uF/16V/B	1
C607	Ceramic capacitor	1uF/16V/B	1
C608	Ceramic capacitor	1uF/16V/B	1
C609	Ceramic capacitor	1uF/16V/B	1
C610	Ceramic capacitor	1uF/16V/B	1
C611	Ceramic capacitor	1uF/16V/B	1
C900	Ceramic capacitor	0.022uF/10V/B	1
R200	Resistor	0	1
R201	Resistor	Not installed	1
R202	Resistor	Not installed	1
R203	Resistor	0	1
R204	Resistor	Not installed	1
R205	Resistor	0	1
R206	Resistor	0	1
R207	Resistor	Not installed	1
R301	Resistor	180 k	1
R303	Resistor	390 k	1
R304	Resistor	390 k	1
R603	Resistor	0	1
R604	Resistor	0	1
R605	Resistor	0	1
R606	Resistor	0	1
VR300	Resistor	200K	1

4.5 Timing Chart (For LCD controller settings)

Horizontal Data Timing

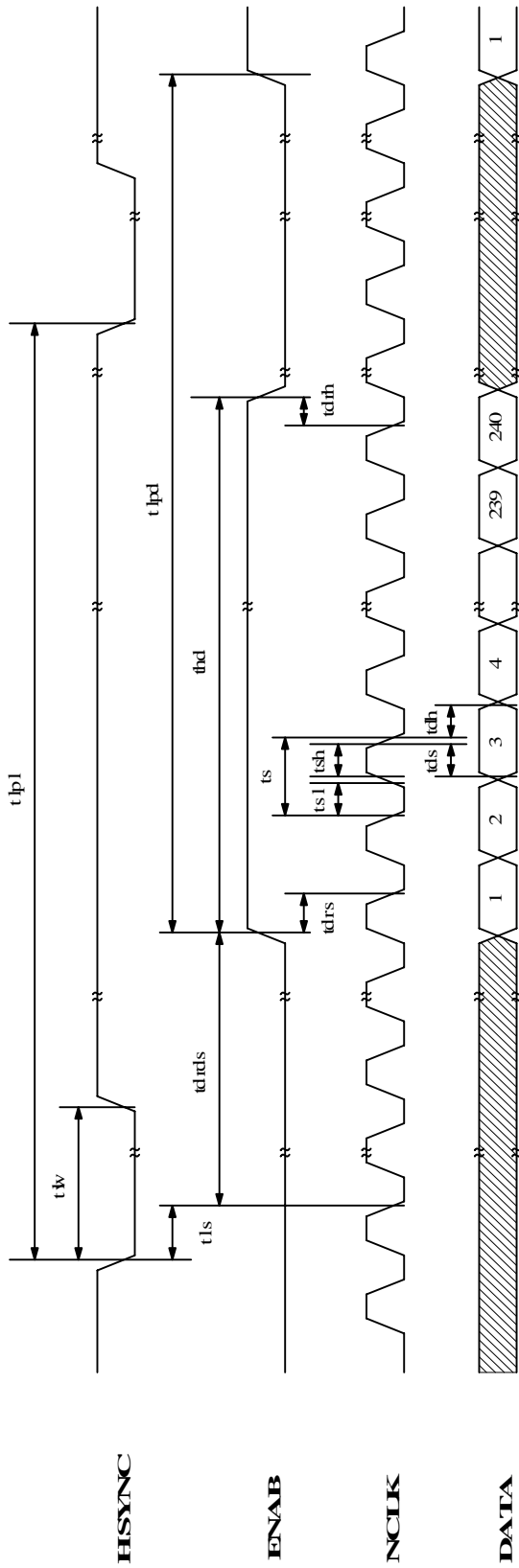

Vertical Data Timing

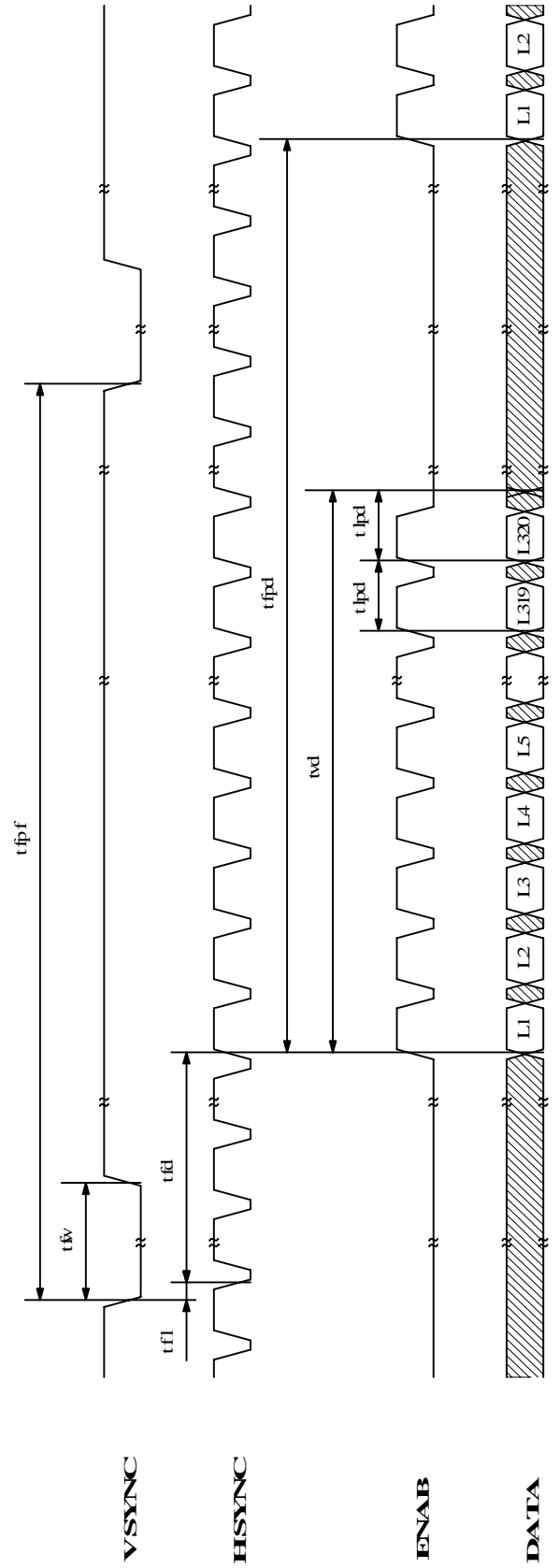

TIMING SPECIFICATION ^{1) 2) 3)} (LCD panel controller input signal)

Signal	Parameter	Symbol	Mn.	Typ.	Max.	Unit	Remarks
NCLK	Clock Period	t_s	244	249	295	ns	4)
	Clock Frequency	$1/t_s$	3.39	4.01	4.1	MHz	
	High Time	t_{sh}	80	$0.5 \times t_s$	-	ns	
	Low Time	t_{sl}	80	$0.5 \times t_s$	-	ns	
HSYNC	Setup to NCLK	t_{fs}	100	$0.5 \times t_s$	-	ns	
	Pulse Width	t_{fw}	$9 \times t_s$	$10 \times t_s$	$16 \times t_s$	-	
VSYNC	Pulse Width	t_{fv}	$2 \times t_{lpd}$	$2 \times t_{lpd}$	-	-	
	VSYNC to DATA	t_{fd}	$4 \times t_{lpd}$	$6 \times t_{lpd}$	-	-	
	Setup to HSYNC	t_{fl}	0	-	-	ns	
	Line Period	$t_{lpd}=t_{lpl}$	$272 \times t_s$	$272 \times t_s$	$272 \times t_s$	-	4)
				67.7		ms	
	Horizontal Display Time	t_{hd}	$240 \times t_s$	$240 \times t_s$	$240 \times t_s$	-	
	Frame Frequency	$1/t_{fpd}$	38	45	46	Hz	
	Frame Period	$t_{fpd}=t_{fpl}$	$328 \times t_{lpd}$	$328 \times t_{lpd}$	$328 \times t_{lpd}$	-	
	Vertical Display Time	t_{vd}	$320 \times t_{lpd}$	$320 \times t_{lpd}$	$320 \times t_{lpd}$	-	
	Setup	t_{ds}	20	$0.5 \times t_s$	-	ns	
	Hold	t_{dh}	20	$0.5 \times t_s$	-	ns	
ENAB	Setup	t_{drs}	20	$0.5 \times t_s$	-	ns	
	Hold	t_{drh}	20	$0.5 \times t_s$	-	ns	
	Display Start	t_{drds}	-	$16 \times t_s$	20	-	

Note 1) When ENAB is fixed to "H" level or "L" level after NCLK input, the panel is displayed as black. However, it may be occurred a flicker on the display.

Note 2) When NCLK is fixed to "H" level or "L" level, the panel becomes white stage after several seconds.

Note 3) Do not change t_s and t_{lpd} values in the operation. When t_s or t_{lpd} is changed, the panel is displayed as black.

Note 4) Please adjust LCD operating signal timing and LED driving frequency, to optimize the display quality. There is a possibility that flicker is observed by the interference of LCD operating signal timing and LED driving condition (especially driving frequency).

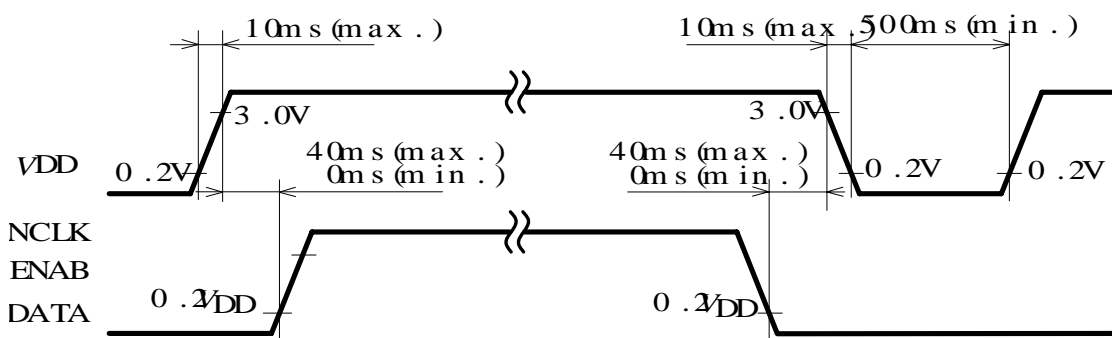
SEQUENCE OF POWER SUPPLIES AND SIGNALS

5. Optical Characteristics

5.1 Test Conditions

It is same as 4.1

The measuring method is shown in 11.

5.2 Optical Specifications ¹⁾

	Item	Symbol	Conditions	Specifications			Unit	Remark	
				Min.	Typ.	Max.			
F L O F F	Contrast Ratio	CR	$=0^\circ, =0^\circ$	3.0	10.0	---	---		
	Response Time	Rise	t_{ON}	$=0^\circ$	10->90%	---	---	50	ms
		Fall	t_{OFF}	$=0^\circ$	90->10%	---	---	50	ms
	Reflectance	R	Level=15 (White)	5	20	---	---	%	
	Chromaticity	Red	x_R	Red	0.33	0.42	0.51	---	
			y_R		0.21	0.30	0.39	---	
		Green	x_G	Green	0.21	0.30	0.39	---	
			y_G		0.35	0.44	0.53	---	
		Blue	x_B	Blue	0.11	0.20	0.29	---	
			y_B		0.13	0.22	0.31	---	
White		x_W	White	0.25	0.32	0.39	---		
		y_W		0.29	0.36	0.43	---		
F L O N	Contrast Ratio	CR	$=0^\circ, =0^\circ$	3.0	10.0	---	---		
	Viewing Angle		CR 2	= 180 °	20	---	---	0	
				= 0 °	20	---	---	0	
				= + 90 °	40	---	---	0	
				= - 90 °	30	---	---	0	
	Response Time	Rise	t_{ON}	$=0^\circ$	10->90%	---	---	50	ms
		Fall	t_{OFF}	$=0^\circ$	90->10%	---	---	50	ms
	Luminance	L	$\theta=0^\circ, \phi=0^\circ$ Level=L15 (White)	30	50	---	---	cd/m ²	$I_{FL}=20mA$
	Luminance Uniformity	LUNF	$\theta=0^\circ, \phi=0^\circ$ Gray Scale Level=L15 (White)	55	---	---	---	%	
	Chromaticity	Red	x_R	Red	0.31	0.40	0.49	-	
y_R			0.20		0.29	0.38	-		
Green		x_G	Green	0.21	0.30	0.39	-		
		y_G		0.28	0.37	0.46	-		
Blue		x_B	Blue	0.10	0.19	0.28	-		
		y_B		0.08	0.17	0.26	-		
White		x_W	White	0.24	0.31	0.38	-		
		y_W		0.24	0.31	0.38	-		

Note 1): Refer to "11. Measuring Method".

6. Quality

6.1 Test Conditions

- 1) Ambient Temperature : 25±5°C
- 2) Ambient Humidity : 65±20%(RH)
- 3) Illumination : Approximately 2000lx , 500 lx under the fluorescent lamp
- 4) Viewing Distance : Approximately 0.3m by the eyes of the inspector from the LCD module

6.2 Dimensional Outline

The products shall conform to the dimensions specified in 2.3.2.

6.3 Appearance Test

6.3.1 Test Conditions

- 1) Condition : Non-operating, operating (Pattern : L15 white raster)
Same as 6.1

6.3.2 Specifications

Item	Description																									
Cosmetics ¹⁾	Circular																									
	<table border="1"> <thead> <tr> <th>Average diameter(mm)</th> <th>Minimum Distance(mm)</th> <th>Maximum quantity</th> </tr> </thead> <tbody> <tr> <td>D≤0.15</td> <td>---</td> <td>Neglect</td> </tr> <tr> <td>0.15<D≤0.25</td> <td>15</td> <td>5</td> </tr> <tr> <td>0.25<D</td> <td>---</td> <td>0</td> </tr> </tbody> </table>	Average diameter(mm)	Minimum Distance(mm)	Maximum quantity	D≤0.15	---	Neglect	0.15<D≤0.25	15	5	0.25<D	---	0													
	Average diameter(mm)	Minimum Distance(mm)	Maximum quantity																							
	D≤0.15	---	Neglect																							
	0.15<D≤0.25	15	5																							
	0.25<D	---	0																							
	Liner																									
	<table border="1"> <thead> <tr> <th>Width(mm)</th> <th>Length(mm)</th> <th>Minimum Distance(mm)</th> <th>Maximum quantity</th> </tr> </thead> <tbody> <tr> <td>W≤0.03</td> <td>---</td> <td>---</td> <td>Neglect</td> </tr> <tr> <td rowspan="3">0.03<W≤0.15</td> <td>L≤0.5</td> <td>---</td> <td>Neglect</td> </tr> <tr> <td>0.5<L≤1.0</td> <td>15</td> <td>9</td> </tr> <tr> <td>1.0<L≤2.0</td> <td>15</td> <td>4</td> </tr> <tr> <td rowspan="2">0.15<W</td> <td>2.0<L</td> <td>---</td> <td>0</td> </tr> <tr> <td>---</td> <td>---</td> <td>0</td> </tr> </tbody> </table>	Width(mm)	Length(mm)	Minimum Distance(mm)	Maximum quantity	W≤0.03	---	---	Neglect	0.03<W≤0.15	L≤0.5	---	Neglect	0.5<L≤1.0	15	9	1.0<L≤2.0	15	4	0.15<W	2.0<L	---	0	---	---	0
	Width(mm)	Length(mm)	Minimum Distance(mm)	Maximum quantity																						
	W≤0.03	---	---	Neglect																						
0.03<W≤0.15	L≤0.5	---	Neglect																							
	0.5<L≤1.0	15	9																							
	1.0<L≤2.0	15	4																							
0.15<W	2.0<L	---	0																							
	---	---	0																							
T/P	Defect of surface coating : Diagonal≤1.0																									
	Blistering : Total thickness≤+0.4mm																									

Note 1) Inspection area should be within viewing area.

Average Diameter $D = (a+b) / 2$ (mm)

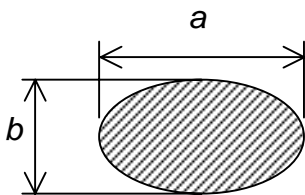

The definition of Length and Width

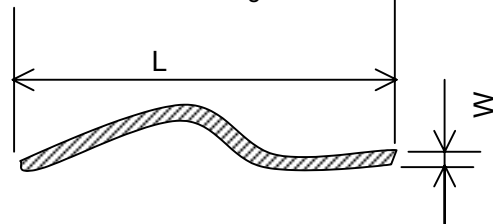

6.4 Display Quality(LCD)

6.4.1 Test Conditions

- 1) Inspection Area : Within active area
- 2) Driving Condition : Same as test conditions shown in 4.1 and 6.1
- 3) Test Pattern : White display pattern (gray scale level L15) and black display pattern (gray scale level L0)

6.4.2 Specifications

Item	Description / Specifications	LCD Patterns
Function	No display, Malfunction	
Display Quality ¹⁾	Missing line	R,G,B,W,Black
	Missing Sub-Pixels	Black
	1) Bright defects (Single) ; N 2pcs. 2) 3) 4) (Two adjacent) ;N 0set. (Three adjacent or more) ;N 0pcs.	
	2) Dark defects (Single) ; N 2pcs. 2) 3) 4) (Two adjacent) ;N 0set. (Three adjacent or more) ;N 0pcs.	
	3) Total defects ; N 4pcs.	R,G,B,W,Black
	Inconspicuous flicker, crosstalk, Newton's ring and other defects : neglect ⁴⁾	-
Black and White Spots/lines	Inconspicuous defects : neglect	-
Frontlight	Missing (Non-operating)	-

Note 1) Defects of both color filter and black matrix are counted as bright or dark defects.

Inspection area should be within the active area.

Note 2) Bright defect means a bright spot(sub-pixel) on the display pattern of gray scale L0(Black).

Dark defect means a dark spot(sub-pixel) on the display pattern of gray scale L15(R,G,B,White).

Note 3) Bright defect which can not be found by using 5%ND-Filter shall not be counted as a defect.

Note 4) INVENTEC ELECTRONICS(NANJING) CO., LTD and Toshiba Matsushita Display Technology Co., Ltd. will discuss it when inconspicuous defect(flicker, crosstalk, Newton ring etc)happen.

6.5 Reliability Test

6.5.1 Test Conditions

- 1) The module should be driven and inspected under normal test conditions.
- 2) The module should not have condensation of water (moisture) on the module.
- 3) The module should be inspected after two or more hours storage in normal conditions (15 - 35°C, 45 - 65%(RH)).
- 4) A module shall be used only for one test.

6.5.2 Specifications

The module shall have no failure in the following reliability test items.

Test Item	Test Conditions	Remark
High Temperature Operation ¹⁾	50°C 192 h	
High Temperature Storage ²⁾	70°C 192 h	
High Temperature and High Humidity operation ¹⁾	50°C 90% 192 h	
High Temperature and High Humidity Storage ²⁾	50°C 90% 192 h	
Low Temperature Operation ¹⁾	0°C 192 h	
Low Temperature Storage ^{2),3)}	-25°C 192 h	
Temperature Shock ^{2),3)}	-25°C ⇔ 70°C 30 min. 5min. 30 min. 50 cycles	

Note 1) Operating

Note 2) Non-Operating

Note 3) Except Front Light

Definitions of failure for judgment shall be as follows:

- 1) Function of the module should be maintained.
- 2) Current consumption should be smaller than the specified value.
- 3) Appearance and display quality should not have distinguished degradation.

6.6 Labels

(1) Product Label

Unit: mm

Serial number : ▲ 1E 0000001 T
 (1) (2) (3) (4)

(1) : Manufacturing code

(2) : Year code-end of the A.D

Month code-alphabet→ Jan. : A - Dec. : L

(Example: 1G→2001 JUL.)

(4) : Serial code

(decimal, 7 figures)

(6) : TOSHIBA MATSUSHITA DISPLAY TECHNOLOGY CO., LTD. internal code

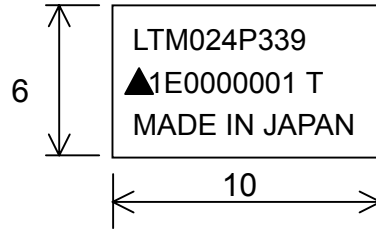

(2) Label Locations

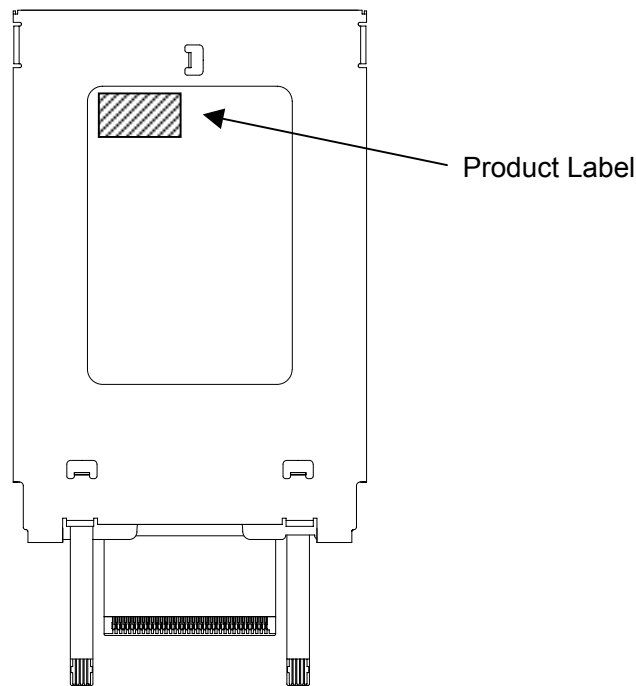

7. Packaging

7.1 Carton (internal package)

(1) Packaging Form

Corrugated cardboard box

(2) Packaging Method

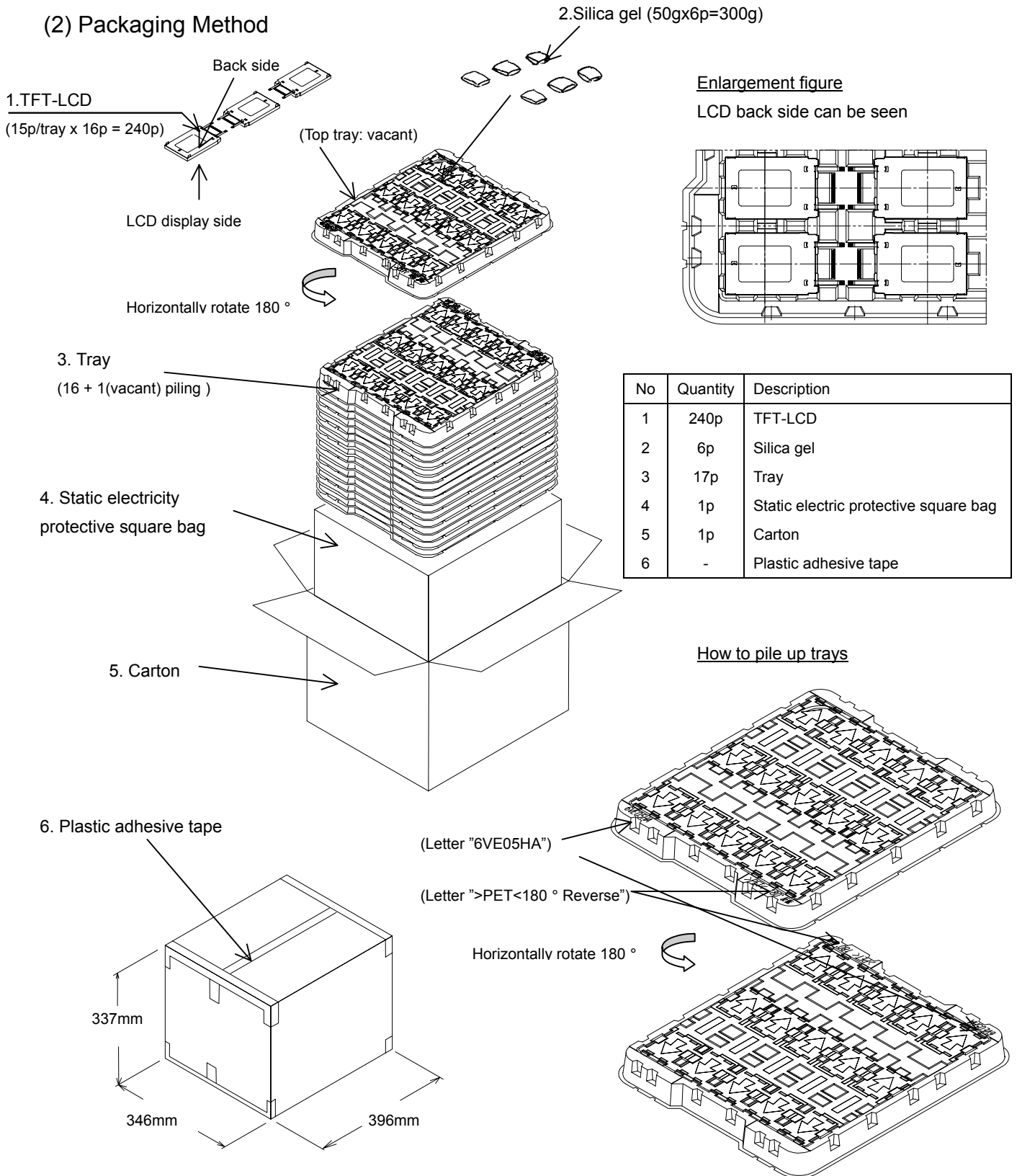

8. Warranty

Warranty clause will be decided separately.

9. Regulation

The set (which our LCD module is assembled into) to conform the regulations below, take measures in set side. Toshiba Matsushita Display Technology Co., Ltd. is not liable for the regulations to the complete set, nor can guarantee our LCD module conform the regulation by itself.

a) Examples of EMI Regulations

FCC : PART15 CLASS B

VCCI : CLASS B

CISPR : CLASS B

b) Examples of Safety Regulations

IEC 950

UL 1950

10. Measuring Method

10.1 Measuring System

1) Frontlight : ON

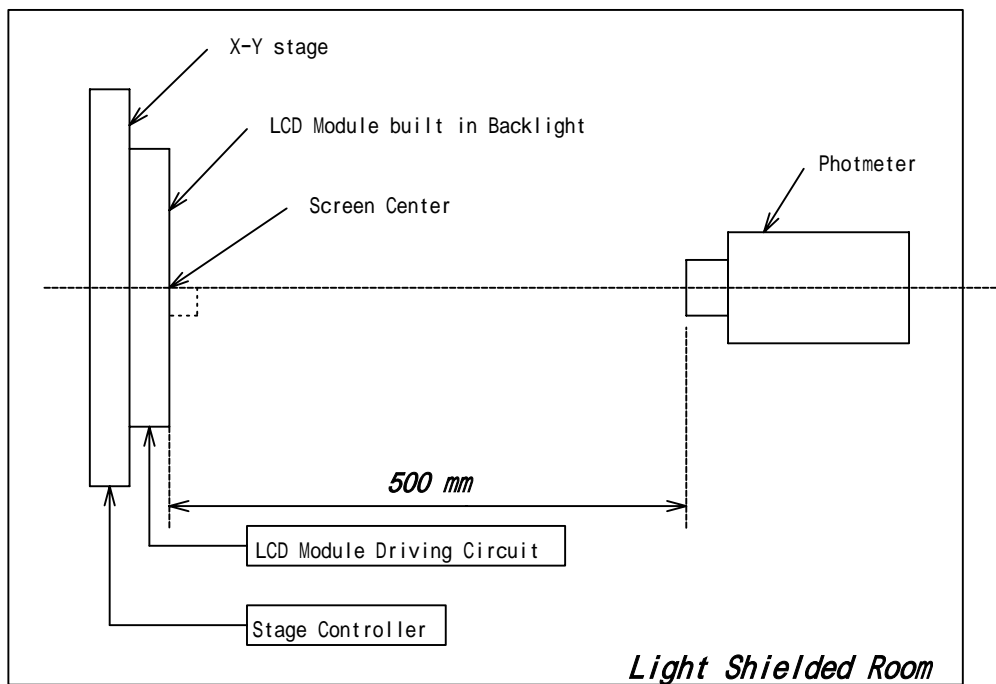

2) Frontlight : OFF

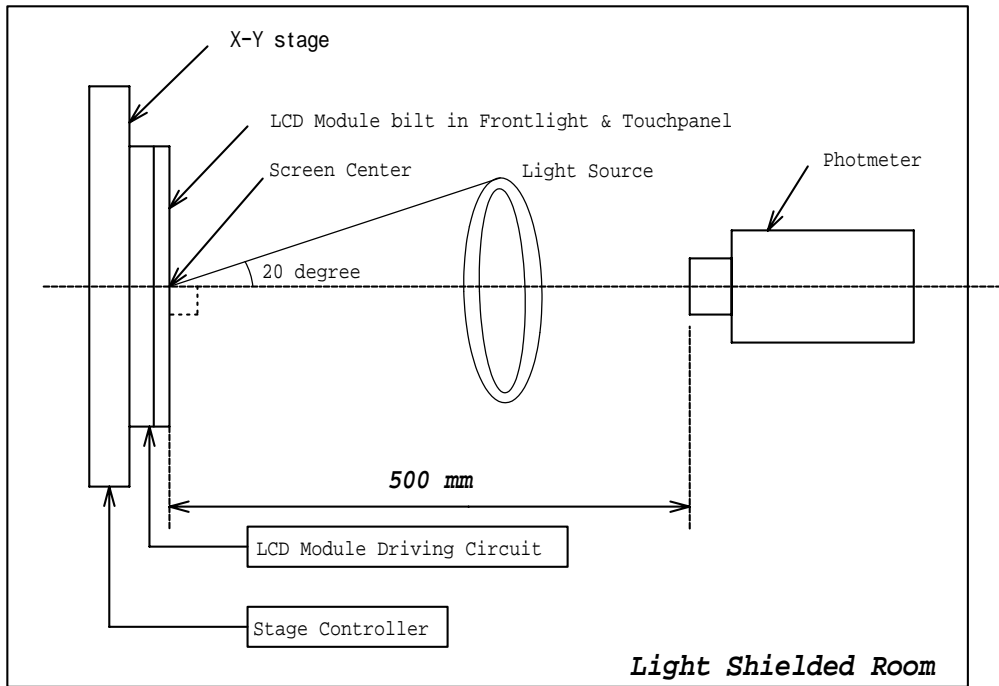

(1) The measurement point is the center of the active area except for the measurement of Luminance Uniformity.

(2) Photometer : BM-7/BM-5A TOPCON (Aperture 1deg.)

(3) Definition of θ and ϕ :

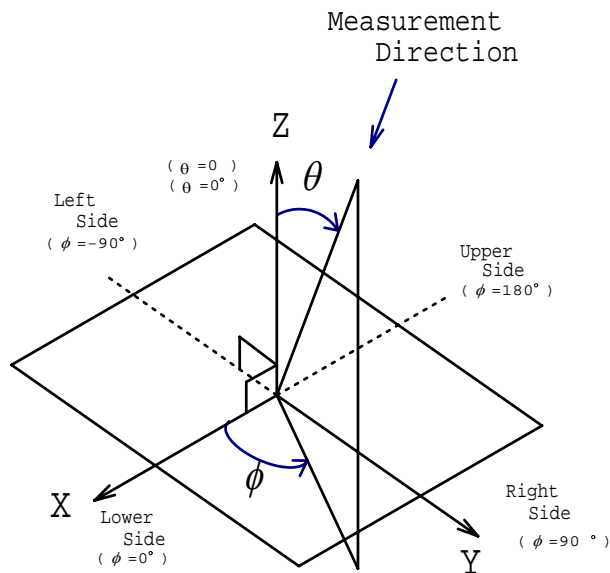

10.2 Measuring Methods

(1) Luminance:

The luminance of the center on a white raster (gray scale level L15) shall be measured.

(2) Contrast Ratio:

The contrast ratio can be calculated by the following expression.

$$\text{Contrast Ratio (CR)} = L15 / L0$$

L15 : Luminance on the white raster (gray scale level L15)

L0 : Luminance on the black raster (gray scale level L0)

(3) Viewing Angle

Viewing angle is defined as the angles (θ, ϕ), in which specified contrast ratio can be obtained.

(Refer to 11.1(3) for the axes.)

(4) Luminance Uniformity:

The Luminance should be measured at 9 positions on white raster(gray scale level L15).

Uniformity can be calculated by the following expression.

$$\text{Luminance Uniformity} = \frac{\text{Minimum Luminance}}{\text{Maximum Luminance}} \times 100\%$$

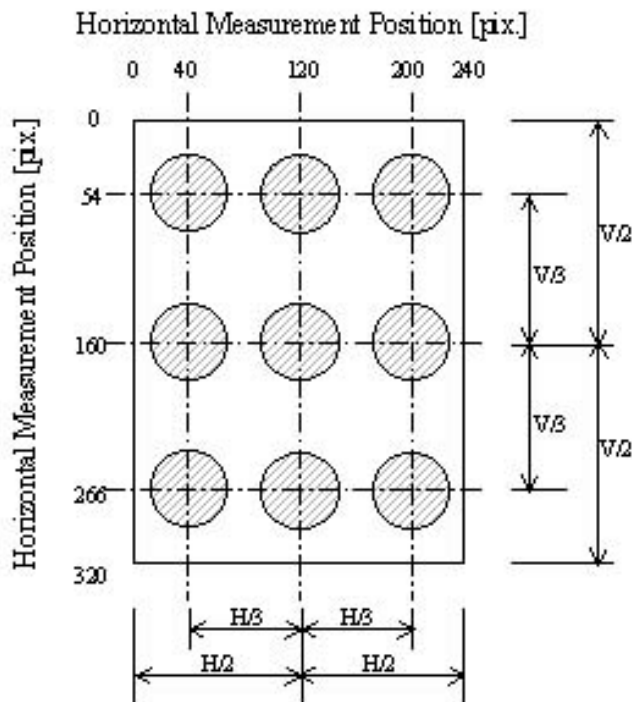

(5) Chromaticity :

The values(x,y) of chromaticity coordinates should be measured for the White, Red, Green and Blue Raster(gray scale level L15) each with a photometer.

(6) Response Time :

The response time (τ_r, τ_d) is measured with a photo detector (photodiode) which measures the light intensity of the pixels.

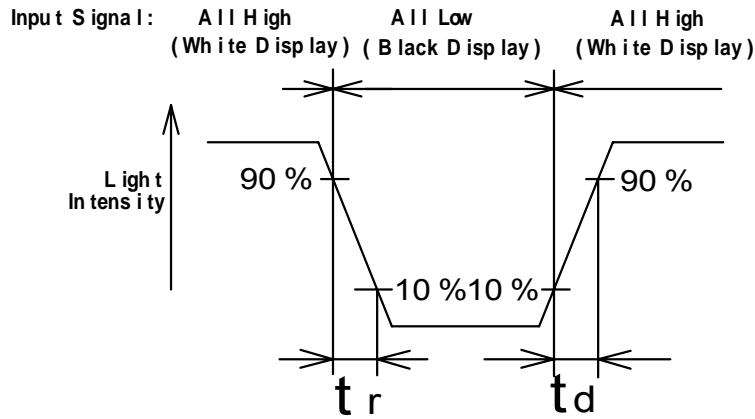

τ_r : Turn on time is the time for a photo detector output waveform to go from 90% value to 10% of its maximum.

τ_d : Turn off time is the time for a photo detector output waveform to go from 10% to 90% of its maximum.

Photodiode : S1223-01 HAMAMATSU PHOTONICS K.K.

White Display : White Raster (gray scale level L15)

Black Display : Black Raster (gray scale level L0)