

**FEATURES**

- (1) 11.1"WIDE-XGA+(1366x768 pixels) display size for notebook PC
- (2) LED Backlight ( LED 40pcs : 10 Serial & 4 Parallel connection )
- (3) Glare surface

**TENTATIVE****MECHANICAL SPECIFICATIONS**

Item	Specifications
Dimensional Outline (typ.)	255.0(W) x 159.9 (H) x 2.55/2.8(D) mm
Number of Pixels	1366 (W) x 768(H) pixels
Active Area	245.88(W) x 138.24(H) mm
Pixel Pitch	0.18(W) x 0.18(H)
Weight (approximately)	146 g
Backlight	LED

**ABSOLUTE MAXIMUM RATINGS**

Item	Min.	Max.	Unit	
Supply Voltage	(V <sub>DD</sub> )	-0.3	4.0	V
	(V <sub>LED</sub> )	0	5.0	V
LED Currency (I <sub>LED</sub> )	-	30	mA	
Input Signal Voltage (V <sub>IN</sub> )	-0.3	V <sub>DD</sub> +0.3	V	
Operating Temperature	0	50	°C	
Storage Temperature	-20	60	°C	
Storage Humidity	10	90	%(RH)	

**ELECTRICAL SPECIFICATION**

Item	Min.	Typ.	Max.	Unit	Remarks	
Supply Voltage	(V <sub>DD</sub> )	3.0	3.3	3.6	V	
Supply LED Currency	(I <sub>LED</sub> )	---	---	16	mA	
Common Mode Input Voltage	(V <sub>CM</sub> )	1.0	1.25	2.0	V	
Differential Input Amplitude	(V <sub>ID</sub> )	250	---	450	mV	
Current Consumption	*1 (I <sub>DD</sub> )	---	295		mA	
	*2 (I <sub>LED</sub> )	---	---	16	mA	
Power Consumption		---	3.1	---	W	I <sub>LED</sub> =16 mA

\*1 : 8 color bars pattern

\*2 : The current value of each row should be the same value.

**OPTICAL SPECIFICATION (T<sub>a</sub>=25°C)**

Item	Min.	Typ.	Max.	Unit	Remarks
Contrast Ratio (CR)	300	600	---	---	
Response Time	(t <sub>ON</sub> )+ (t <sub>OFF</sub> )	---	50	70	ms
Luminance (L)	---	240	---	cd/m <sup>2</sup>	I <sub>LED</sub> =16mA

\*The information contained herein is presented only as a guide for the applications of our products. No responsibility is assumed by Toshiba Matsushita Display technology or other rights of the third parties which may result from its use. No license is granted by implication or otherwise under any patent or patent rights of Toshiba Matsushita Display technology or others.

\*The information contained herein may be changed without prior notice. It is therefore advisable to contact Toshiba Matsushita Display technology before proceeding with the design of equipment incorporating this product.

# TENTATIVE

**DIMENSIONAL OUTLINE**  
(Front side)

Unit : mm  
Standard tolerance : ±0.5

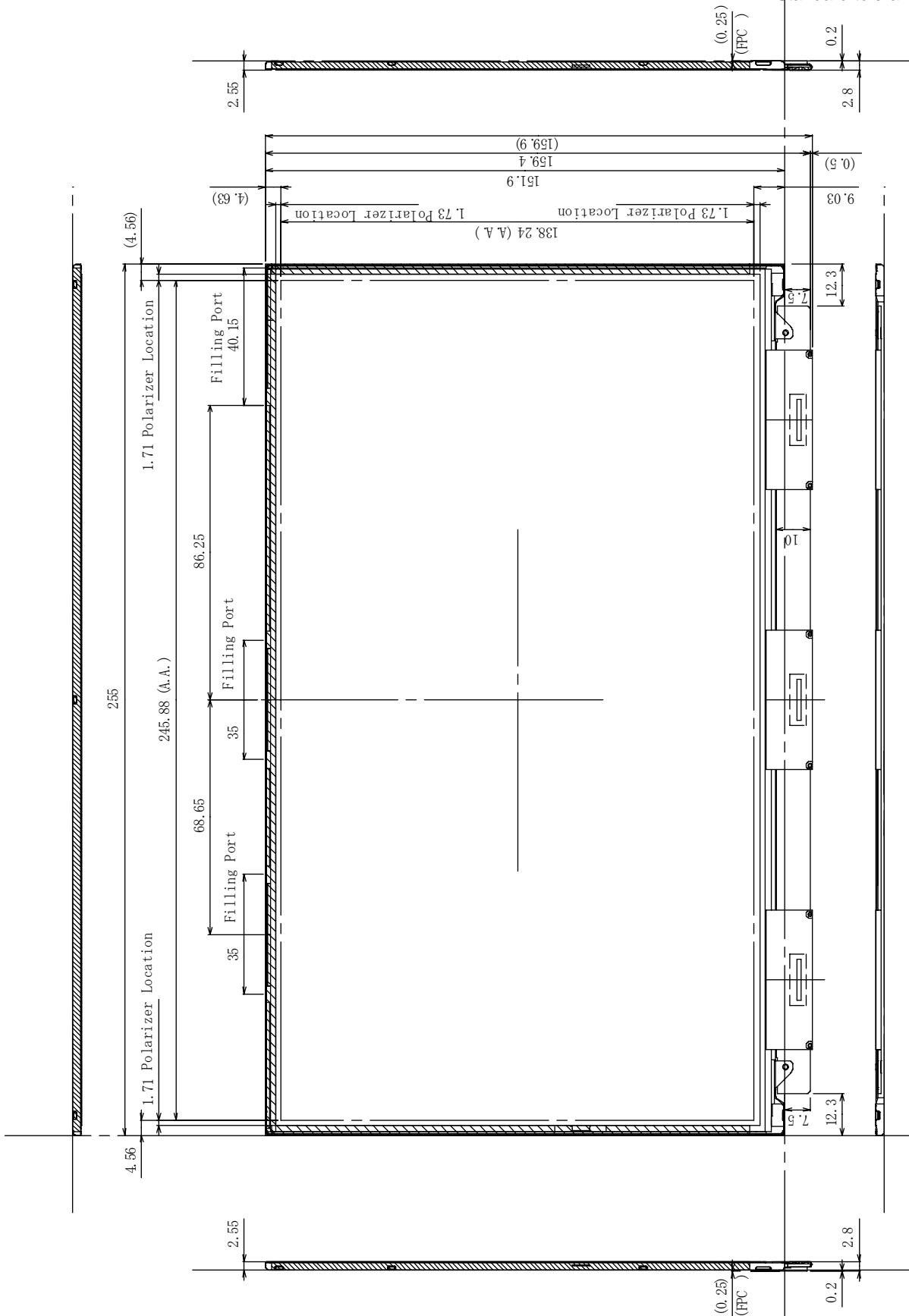

**DIMENSIONAL OUTLINE**  
(Back side)

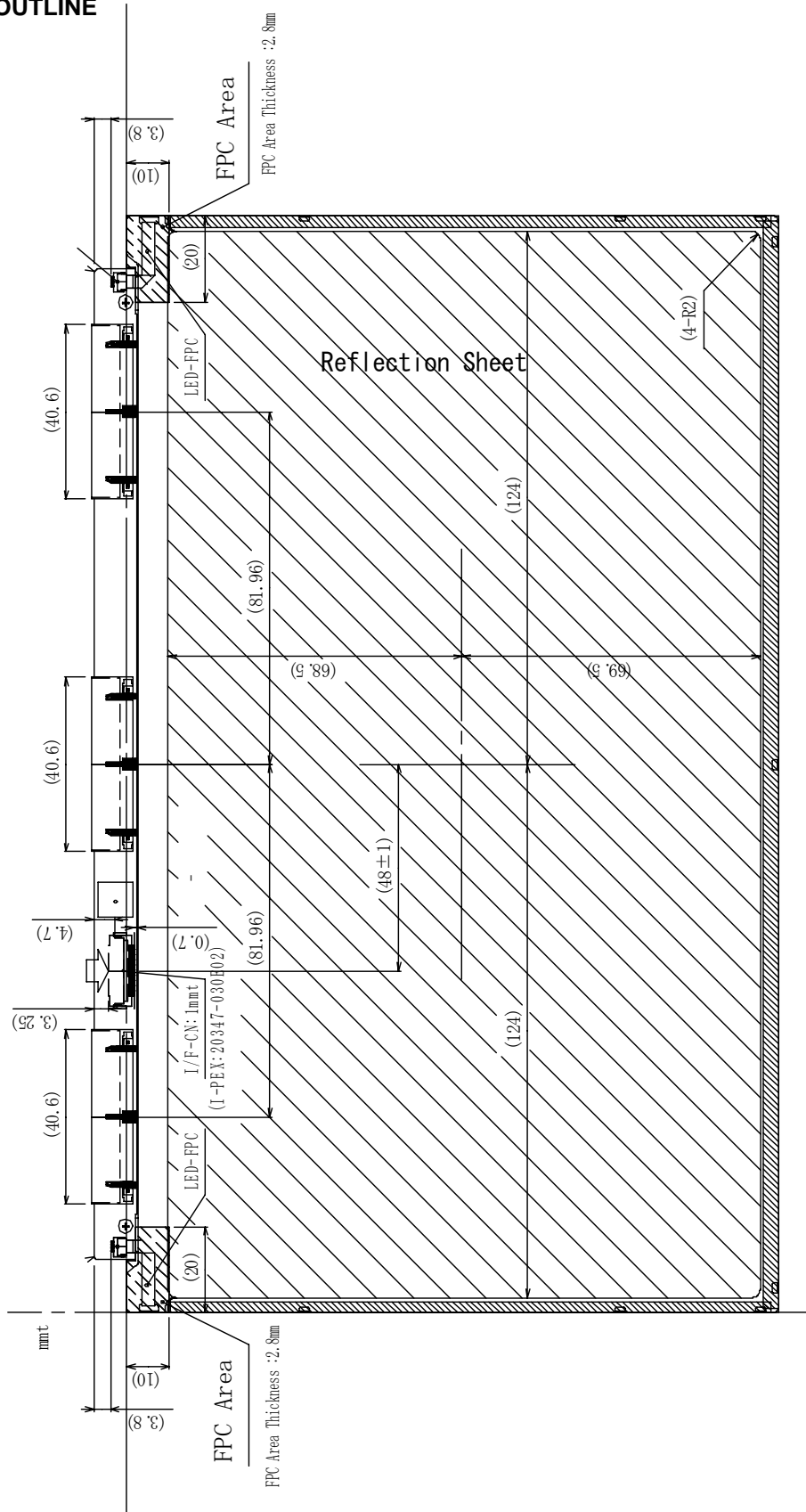

Note 1) Never push LCD back side. If LCD back side was pressed, It may cause damage of the back light system.

**BLOCK DIAGRAM**

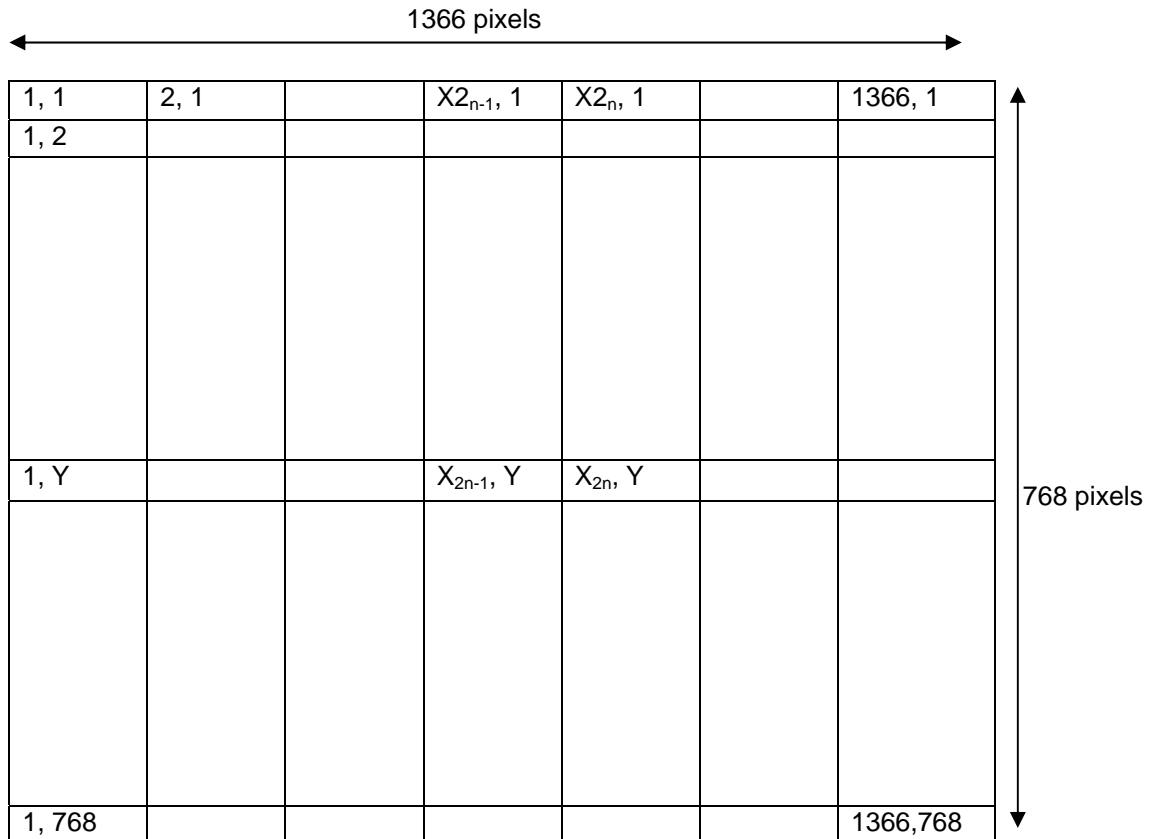
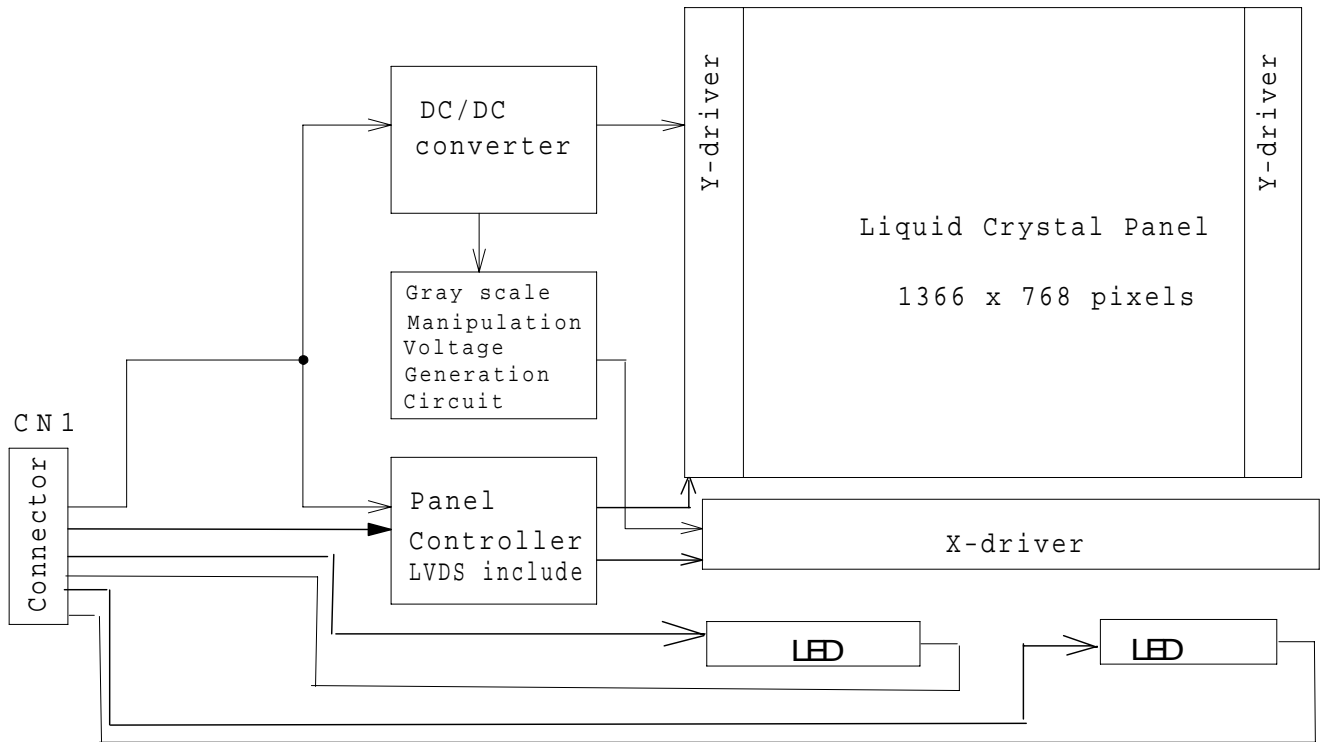

## TIMING CHART

### (1) Vertical Timing

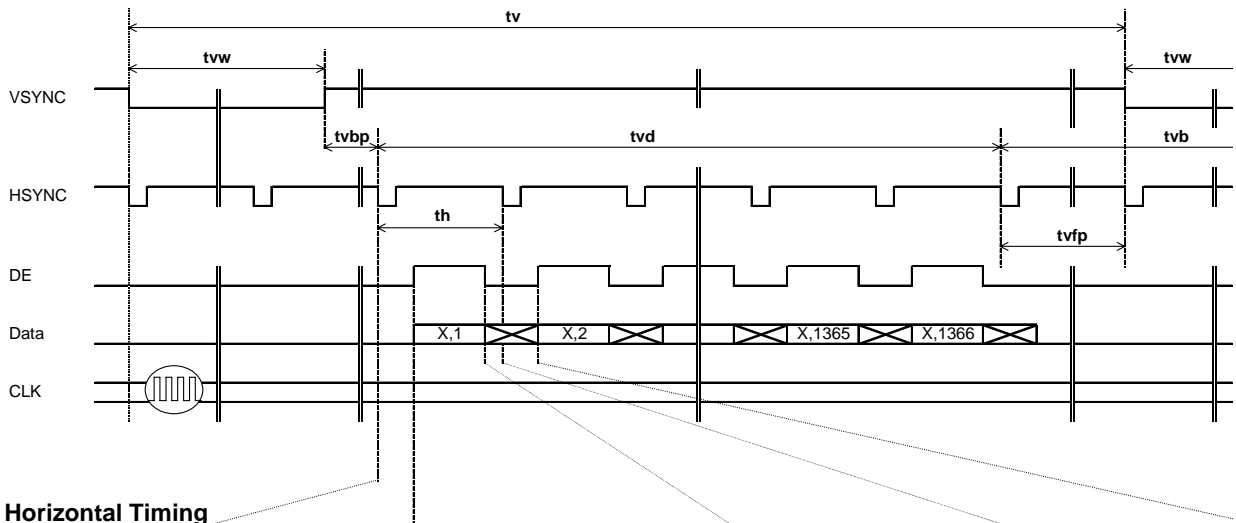

### (2) Horizontal Timing

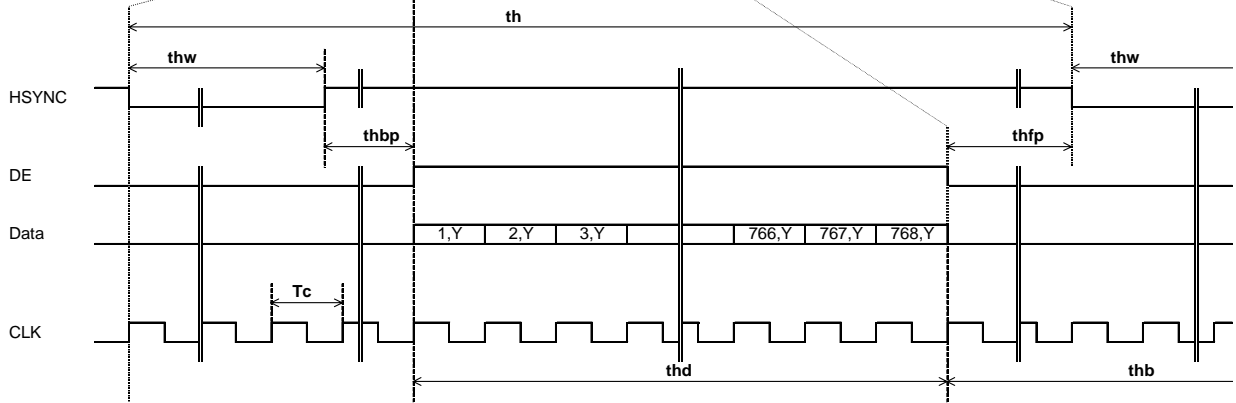

**TIMING SPECIFICATION** <sup>1) 2) 3) 4) 5) 6)</sup>

Item	Symbol	min.	typ.	max.	unit
Horizontal Scanning Term	th	1656 x tc	1664 x tc		clock
		20.70	21.47		μs
H-sync Pulse Width	thw	8 x tc	128 x tc	-	clock
Horizontal Front Porch	thfp	8 x tc	64 x tc	-	clock
Horizontal Back Porch	thbp	8 x tc	106 x tc	-	clock
Horizontal Display Term	thd	1366 x tc	1366 x tc	1366 x tc	clock
Horizontal blanking	thb	290 x tc	298 x tc		clock
Frame Period	tv	774 x th	776 x th		line
		16.02	16.66		ms
V-sync Pulse Width	tw	1 x th	1 x th	-	line
Vertical blanking	td	6 x tc	8 x tc	-	line
Vertical Front Porch	tfp	1 x th	1 x th	-	line
Vertical Back Porch	tbp	4 x th	6 x th	-	line
Vertical Data Sync Period	tds	2 x th	27 x th	-	line
Vertical Display Term	td	768 x th	768 x th	768 x th	line
Clock Period	tc	12.50	12.903		ns
			77.5	80	MHz

Note 1) Refer to "Timing Chart" and LVDS specifications in TIA/EIA-644.

Note 2) If DE is fixed to "H" or "L" level for certain period while NCLK is supplied, the panel displays black with some flicker.

Note 3) If NCLK is fixed to "H" or "L" level for certain period while DE is supplied, the panel may be damaged.

Note4)  $tvb = tw + tfp + tbp$   
 $thb = thw + thfp + thbp$

Note5) In case of using the long frame period, the deterioration of display quality, noise etc. may be occurred.

Note6) NCLK count of each Horizontal Scanning Time should be always the same.

V-Blanking period should be "n" X "Horizontal Scanning Time". (n: integer)

Frame period should be always the same.

## CONNECTOR PIN ASSIGNMENT FOR INTERFACE

### CN1 INPUT SIGNAL

Connector : 20347-030E-02/I-PEX

Mating Connector : 20345-\*30T-##/I-PEX

Terminal No.	Symbol	Function
1	V <sub>ss</sub>	GND
2	RxIN0-	Negative LVDS differential data input (R0-R5,G0)
3	RxIN0+	Positive LVDS differential data input (R0-R5,G0)
4	RxIN1-	Negative LVDS differential data input (G1-G5, B0-B1)
5	RxIN1+	Positive LVDS differential data input (G1-G5, B0-B1)
6	RxIN2-	Negative LVDS differential data input (B2-B5, HSYNC, VSYNC, DE)
7	RxIN2+	Positive LVDS differential data input (B2-B5, HSYNC, VSYNC, DE)
8	CLK-	Clock Signal(-)
9	CLK+	Clock Signal(+)
10	NC	Non-Connection
11	V <sub>ss</sub>	GND
12	V <sub>ss</sub>	GND
13	V <sub>ss</sub>	GND
14	V <sub>ss</sub>	GND
15	V <sub>ss</sub>	GND
16	V <sub>DD</sub>	Power Supply : +3.3V
17	V <sub>DD</sub>	Power Supply : +3.3V
18	V <sub>DD</sub>	Power Supply : +3.3V
19	V <sub>DD</sub>	Power Supply : +3.3V
20	V <sub>DD</sub>	Power Supply : +3.3V
21	NC	Non-Connection
22	VDC11	LED Cathode (Negative)
23	VDC12	LED Cathode (Negative)
24	VDC21	LED Cathode (Negative)
25	VDC22	LED Cathode (Negative)
26	NC	Non-Connection
27	VAC1	LED Anode (Positive)
28	VAC1	LED Anode (Positive)
29	VAC2	LED Anode (Positive)
30	VAC2	LED Anode (Positive)

Note 1) Please connect GND pin to ground. Don't use it as no-connect nor connection with high impedance.

Note 2) Please connect NC to nothing. Don't connect it to ground nor to other signal input.

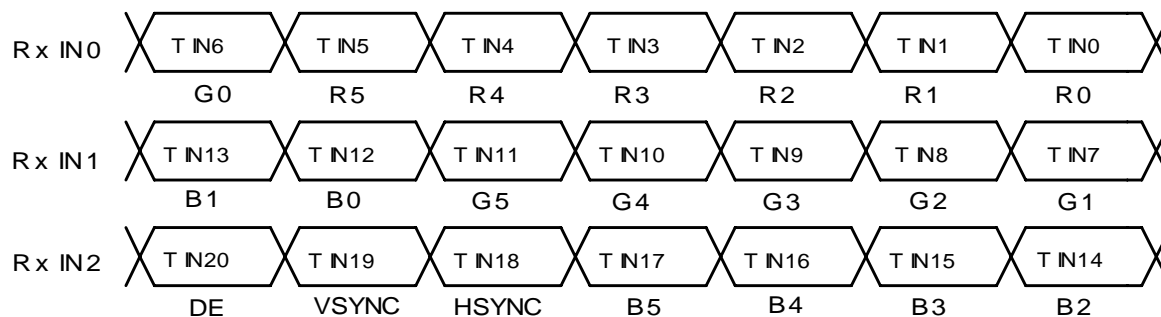

EQUIVALENT CIRCUIT OF LED

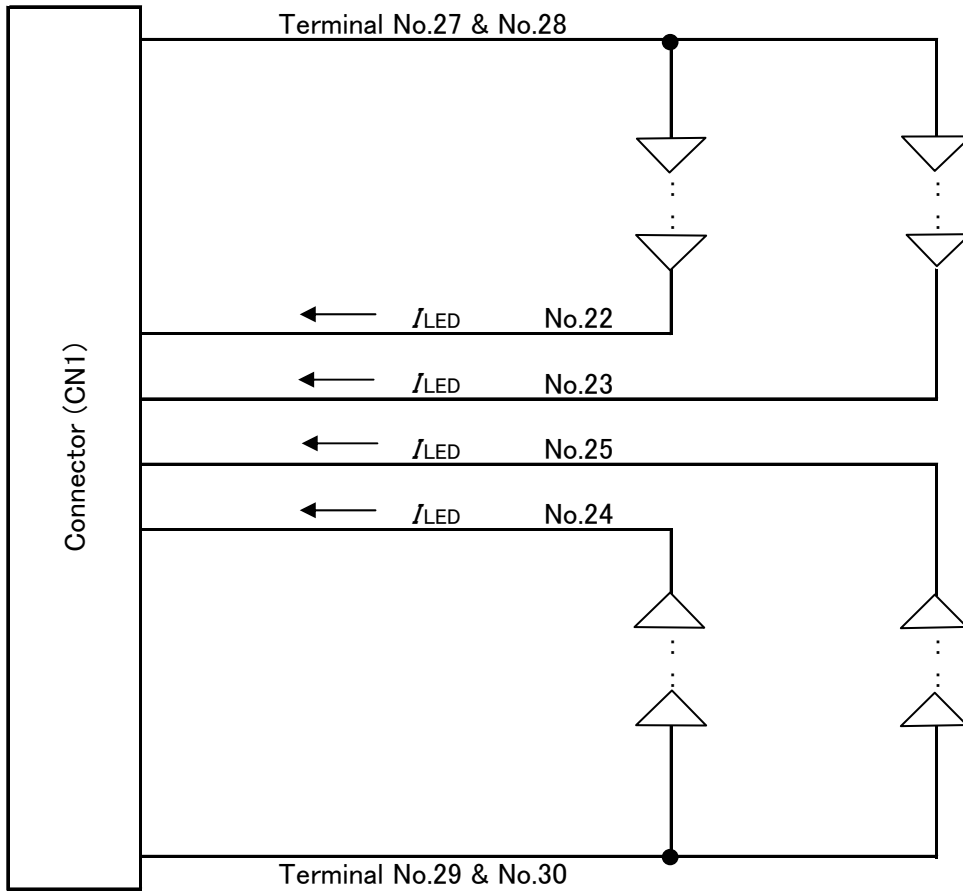



256k (k=1024) COLORS COMBINATION TABLE

	Display	R5 R4 R3 R2 R1 R0	G5 G4 G3 G2 G1 G0	B5 B4 B3 B2 B1 B0	Gray Scale Level
Basic Color	Black	L L L L L L L	L L L L L L L	L L L L L L L	-
	Blue	L L L L L L L	L L L L L L L	H H H H H H H	-
	Green	L L L L L L L	H H H H H H H	L L L L L L L	-
	Light Blue	L L L L L L L	H H H H H H H	H H H H H H H	-
	Red	H H H H H H H	L L L L L L L	L L L L L L L	-
	Purple	H H H H H H H	L L L L L L L	H H H H H H H	-
	Yellow	H H H H H H H	H H H H H H H	L L L L L L L	-
Gray Scale of Red	Black	L L L L L L L	L L L L L L L	L L L L L L L	L 0
	Dark ↑ ↓ Light	L L L L L L H	L L L L L L L	L L L L L L L	L 1
		L L L L L H L	L L L L L L L	L L L L L L L	L 2
		⋮	⋮	⋮	L3... L60
		H H H H L H	L L L L L L L	L L L L L L L	L61
		H H H H H L	L L L L L L L	L L L L L L L	L62
	Red	H H H H H H H	L L L L L L L	L L L L L L L	Red L63
Gray Scale of Green	Black	L L L L L L L	L L L L L L L	L L L L L L L	L 0
	Dark ↑ ↓ Light	L L L L L L L	L L L L L L H	L L L L L L L	L 1
		L L L L L L L	L L L L L H L	L L L L L L L	L 2
		⋮	⋮	⋮	L3... L60
		L L L L L L L	H H H H L H	L L L L L L L	L61
		L L L L L L L	H H H H H L	L L L L L L L	L62
	Green	L L L L L L L	H H H H H H H	L L L L L L L	Green L63
Gray Scale of Blue	Black	L L L L L L L	L L L L L L L	L L L L L L L	L 0
	Dark ↑ ↓ Light	L L L L L L L	L L L L L L L	L L L L L H L	L 1
		L L L L L L L	L L L L L L L	L L L L H L	L 2
		⋮	⋮	⋮	L3... L60
		L L L L L L L	L L L L L L L	H H H H L H	L61
		L L L L L L L	L L L L L L L	H H H H H L	L62
	Blue	L L L L L L L	L L L L L L L	H H H H H H H	Blue L63
Gray Scale of White & Black	Black	L L L L L L L	L L L L L L L	L L L L L L L	L 0
	Dark ↑ ↓ Light	L L L L L H	L L L L L H	L L L L L H	L 1
		L L L L H L	L L L L H L	L L L L H L	L 2
		⋮	⋮	⋮	L3... L60
		H H H H L H	H H H H L H	H H H H L H	L61
		H H H H H L	H H H H H L	H H H H H L	L62
	White	H H H H H H H	H H H H H H H	H H H H H H H	White L63

**FOR SAFETY**

LCD module is generally designed with precise parts to achieve light weighted thin mechanical dimensions. In using our Modules, make certain that you fully understand and put into practice the warnings and safety precautions detailed in Engineering Information No.EE-D-001A,"CAUTIONS AND INSTRUCTIONS FOR TOSHIBA MATSUSHITA DISPLAY TECHNOLOGY CO., LTD LCD MODULES". Refer to individual specifications and TECHNICAL DATA sheets (hereinafter called "TD") for more detailed technical information.

**1) SPECIAL PURPOSES**

- A) Toshiba Matsushita Display technology's Standard LCD Modules have not been customized for operation in extreme environments or for use in applications where performance failures could be life-threatening or otherwise catastrophic.
- B) Since Toshiba Matsushita Display technology's Standard LCD Modules have not been designed for operation in extreme environments, they must never be used in devices that will be exposed to abnormally high levels of vibration or shock which exceed Toshiba Matsushita Display technology's published specification limits.
- C) In addition, since Toshiba Matsushita Display technology Standard LCD Modules have not been designed for use in applications where performance failures could be life-threatening or catastrophic, they must never be installed in aircraft navigation control systems (such as, but not limited to Traffic Collision Avoidance System and Air Traffic Indicator), in military defense or weapons systems, in critical industrial process-control systems (e.g., those involved in the production of nuclear energy), or in critical medical device or patient life-support systems.

**2) DISASSEMBLING OR MODIFICATION**

DO NOT DISASSEMBLE OR MODIFY the module. It may damage sensitive parts inside LCD module, and may cause scratches or dust on the display. Toshiba Matsushita Display technology does not warrant the module, if customer disassembled or modified it.

**3) BREAKAGE OF LCD PANEL**

DO NOT INGEST liquid crystal material, DO NOT INHALE this material, and DO NOT CONTACT the material with skin, if LCD panel is broken and liquid crystal material spills out. If liquid crystal material comes into mouth or eyes, rinse mouth or eyes out with water immediately. If this material contact with skin or cloths, wash it off immediately with alcohol and rinse thoroughly with water.

**4) GLASS OF LCD PANEL**

BE CAREFUL WITH CHIPS OF GLASS that may cause injuring fingers or skin, when the glass is broken.

**5) ELECTRIC SHOCK**

DISCONNECT POWER SUPPLY before handling LCD module. DO NOT TOUCH the parts inside LCD module and the fluorescent lamp's connector or cables in order to prevent electric shock, because high voltage is supplied to these parts from the inverter unit while power supply is turned on.

**6) ABSOLUTE MAXIMUM RATINGS AND POWER PROTECTION CIRCUIT**

DO NOT EXCEED the absolute maximum rating values under the worst probable conditions caused by the supply voltage variation, input voltage variation, variation in parts' constants, environmental temperature, etc., otherwise LCD module may be damaged. Employ protection circuit for power supply, whenever the specification or TD specifies it. Suitable protection circuit should be applied for each system design.

**7) DISPOSAL**

When dispose LCD module, obey to the applicable environmental regulations.