

All information is subject to change without notice. Please read bottom notes.

FEATURES:(1)10.4" VGA color display with High Luminance (400cd/m²)
 (2)Wide Viewing Angle (Vertical:100, Horizontal:120)
 (3)Built in Long Life Lamps (50,000 h)

TENTATIVE**MECHANICAL SPECIFICATIONS**

Item	Specifications
Dimensional Outline (typ.)	238.5(W) x 177.5(H) x 12max(D) mm
Number of Pixels	640(W) x 480(H) pixels
Active Area	211.2(W) x 158.4(H) mm
Pixel Pitch	0.33(W) x 0.33(H)
Weight (approximately)	TBDg
Backlight	Twin CCFLs, Sidelight type

ABSOLUTE MAXIMUM RATINGS

Item	Min.	Max.	Unit	
Supply Voltage	(V _{DD})	-0.3	6.5	V
	(V _{FL})	0	2.0	kV(rms)
FL Driving Frequency (f _{FL})	0	100	kHz	
Input Signal Voltage (V _{IN})	-0.3	V _{DD} +0.3	V	
Operating Temperature	(0)	(50)	°C	
Storage Temperature	-20	(60)	°C	
Storage Humidity (Max. wet bulb temperature = 39°C)	10	90	%(RH)	

ELECTRICAL SPECIFICATION (Ta=25°C)

Item	Min.	Typ.	Max.	Unit	Remarks	
Supply Voltage	(V _{DD})	4.75	5.0	5.25	V	V _{DD} :5V
		3.0	3.3	3.6	V	V _{DD} :3.3V
	(V _{FL})	---	(TBD)	---	V(rms)	
FL Start Voltage	(TBD)	---	---	V(rms)	Ta=0°C	
High Level Input Voltage (V _{IH})	0.7 V _{DD}	---	V _{DD}			
Low Level Input Voltage (V _{IL})	0	---	0.3 V _{DD}	V		
Current Consumption	*1 (I _{DD})	---	(TBD)	---	mA	
	*2 (I _{FL})	3.0	6.0	6.5	mA(rms)	
*1*2 Power Consumption	---	(TBD)	---	W	I _{FL} =6.0mA(rms) V _{DD} :3.3V	

*1 : 8 color bars pattern

*2 : Except the efficiency of FL inverter

OPTICAL SPECIFICATION (Ta=25°C)

Item	Min.	Typ.	Max.	Unit	Remarks
Contrast Ratio (CR)	100	300	---	---	
Viewing Angle (CR ≥ 10)	(Upper+Lower)	---	100	---	°
	(Left+Right)	---	120	---	°
Response Time	(τ _r)	---	---	50	ms
	(τ _f)	---	---	50	ms
Luminance	---	(400)	---	cd/m ²	I _{FL} =6.0mA(rms)
Lamp Life Time (MTBF)*3 *4		50,000		h	

*3 : Conditions ; Ta=25°C, I_{FL}=6.0mA(rms), continuous lighting

*4 : Definitions of failure ; 1) Lcd luminance becomes half of the minimum value. 2) Lamp doesn't light normally.

*The information contained herein is presented only as a guide for the applications of our products. No responsibility is assumed by Toshiba Matsushita Display Technology or other rights of the third parties which may result from its use. No license is granted by implication or otherwise under any patent or patent rights of Toshiba Matsushita Display Technology or others.

*The information contained herein may be changed without prior notice. It is therefore advisable to contact Toshiba Matsushita Display Technology before proceeding with the design of equipment incorporating this product.

BLOCK DIAGRAM

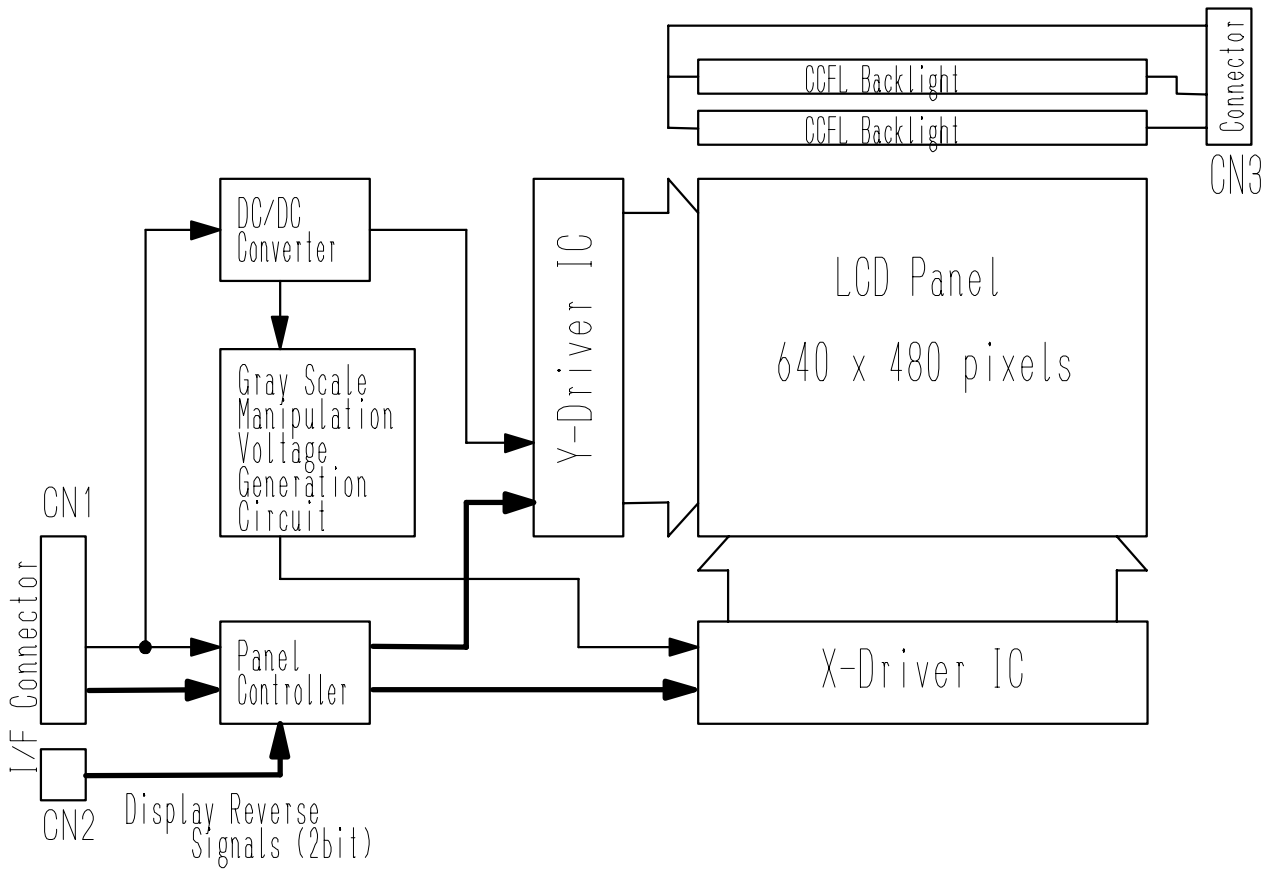

SEQUENCE OF POWER SUPPLIES AND SIGNALS

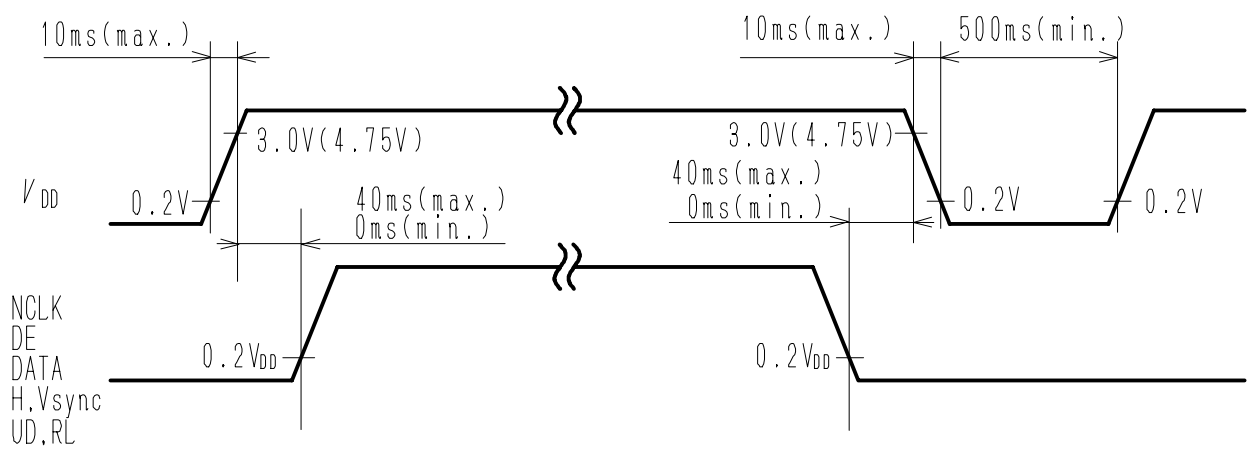

TIMING CHART

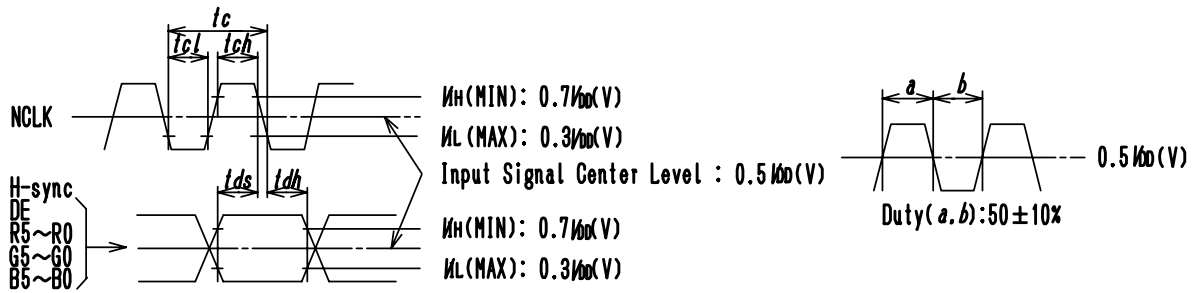
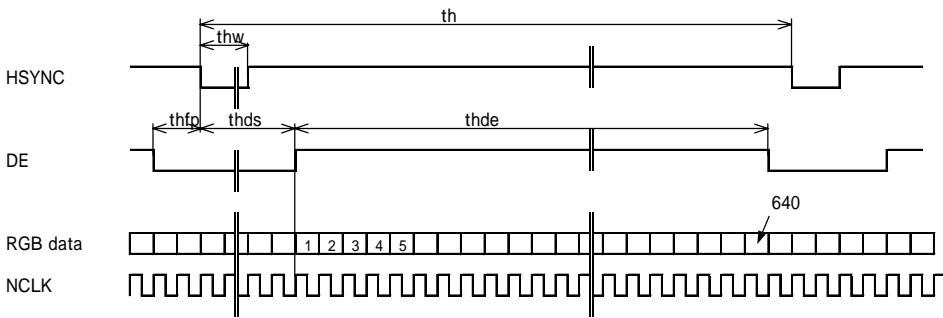
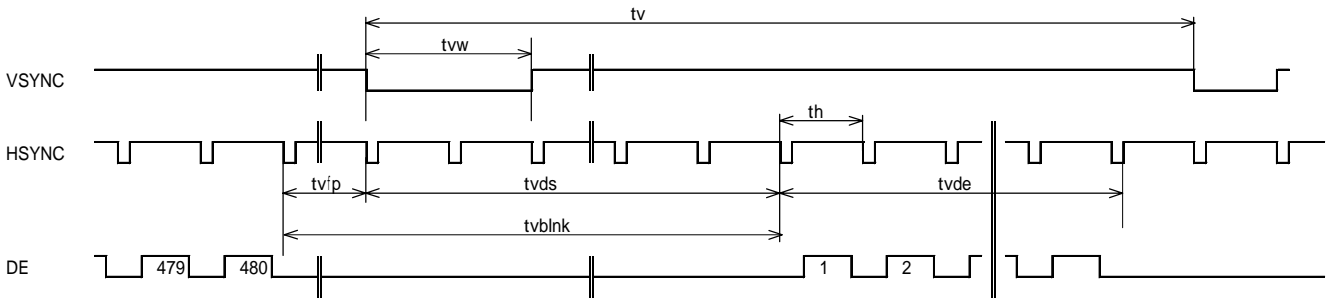

TIMING SPECIFICATION ^{1) 2) 3) 4) 5) 6)}

Item	Symbol	min.	typ.	Max.	unit
Frame Period	<i>tv</i>	TBD	525	TBD	<i>th</i>
Vertical blanking Term	<i>tvblnk</i>	TBD	45	TBD	<i>th</i>
V-sync Pulse Width	<i>tvw</i>	2	-	-	<i>th</i>
Vertical Front Porch	<i>tvfp</i>	2	-	-	<i>th</i>
Vertical Data Sync Period	<i>tvds</i>	6	-	-	<i>th</i>
Vertical Display Term	<i>tvde</i>	480	480	480	<i>th</i>
Horizontal Period	<i>th</i>	TBD	800	TBD	<i>tc</i>
Horizontal blanking Term	<i>thblnk</i>	TBD	160	TBD	<i>tc</i>
H-sync Pulse Width	<i>thw</i>	8	-	-	<i>tc</i>
Horizontal Front Porch	<i>thfp</i>	8	-	-	<i>tc</i>
Horizontal Data Sync Period	<i>thds</i>	16	-	-	<i>tc</i>
Horizontal Display Term	<i>thde</i>	640	640	640	<i>tc</i>
Clock Period	<i>tc</i>	TBD	39.7	-	ns
Clock "H" Time	<i>tch</i>	7.0	-	-	ns
Clock "L" Time	<i>tcl</i>	7.0	-	-	ns
Data Setup Time	<i>tds</i>	2.0	-	-	ns
Data Hold Time	<i>tdh</i>	4.0	-	-	ns

Note 1) If NCLK is fixed to "H" or "L" level for certain period while DE is supplied, the panel may be damaged.

Note 2) Please adjust LCD operating signal timing and FL driving frequency, to optimize the display quality.

There is a possibility that flicker is observed by the interference of LCD operating signal timing and FL driving condition (especially driving frequency), even if the condition satisfies above timing specifications and recommended operating conditions shown in 3.

Note3) Do not make *tv*, *th* and *tvds* fluctuate.

Note4) In case of using the long frame period, the deterioration of display quality, noise etc. may be occurred.

Note5) NCLK count of each Horizontal Scanning Time should be always the same.

V-Blanking period should be "*n*" X "Horizontal Scanning Time". (*n*: integer)

Frame period should be always the same.

CONNECTOR PIN ASSIGNMENT FOR INTERFACE

CN1 INPUT SIGNAL

Connector : DF14H-30P-1.25H / HIROSE ELECTRIC CO., LTD.

Mating Connector : DF14-30S-1.25C, Contact Pin : DF14-2628SCF

Terminal No.	Symbol	Function
1	GND	
2	NCLK	SAMPLING CLOCK
3	H-Sync	HORIZONTAL SYNC.
4	V-Sync	VERTICAL SYNC.
5	GND	
6	R0 ²⁾	RED DISPLAY DATA (LSB)
7	R1 ²⁾	RED DISPLAY DATA
8	R2 ²⁾	RED DISPLAY DATA
9	R3 ²⁾	RED DISPLAY DATA
10	R4 ²⁾	RED DISPLAY DATA
11	R5 ²⁾	RED DISPLAY DATA (MSB)
12	GND	
13	G0 ²⁾	GREEN DISPLAY DATA (LSB)
14	G1 ²⁾	GREEN DISPLAY DATA
15	G2 ²⁾	GREEN DISPLAY DATA
16	G3 ²⁾	GREEN DISPLAY DATA
17	G4 ²⁾	GREEN DISPLAY DATA
18	G5 ²⁾	GREEN DISPLAY DATA (MSB)
19	GND	
20	B0 ²⁾	BLUE DISPLAY DATA (LSB)
21	B1 ²⁾	BLUE DISPLAY DATA
22	B2 ²⁾	BLUE DISPLAY DATA
23	B3 ²⁾	BLUE DISPLAY DATA
24	B4 ²⁾	BLUE DISPLAY DATA
25	B5 ²⁾	BLUE DISPLAY DATA (MSB)
26	DE	DATA ENABLE
27	GND	
28	VDD	+3.3V (+5.0V)POWER SUPPLY
29	VDD	+3.3V (+5.0V)POWER SUPPLY
30	GND	

CN2 INPUT SIGNAL

Connector : DF14H-2P-1.25H / HIROSE ELECTRIC CO., LTD.

Mating Connector : DF14-2S-1.25C, Contact Pin : DF14-2628SCF

Terminal No.	Symbol	Function
1	U D	VERTICAL REVERSE("L" level or Open ; normal, "H" level ; reverse)
2	R L	HORIZONTAL REVERSE ("L" level or Open ; normal, "H" level ; reverse)

CN3 / 4 CCFL POWER SOURCE

Connector : BHR-04VS-1 / JAPAN SOLDERLESS TERMINAL MFG CO., LTD.

Mating Connector³⁾ : SM04(4.0)B-BHS-1 / JAPAN SOLDERLESS TERMINAL MFG CO., LTD.

Terminal No.	Symbol	Function
1	VFLH1	CCFL Power Supply (high voltage)
2	VFLH2	CCFL Power Supply (high voltage)
3	NC ¹⁾	Non Connection (open)
4	VFLL	CCFL Power Supply (low voltage)

Note 1) NC terminal should be open.

Note 2) See next page.

Note 3) Take away terminal No.3 of the mating connector. If does not take away, it may cause smoke burn of electrical parts by high voltage.

256k (k=1024) COLORS COMBINATION TABLE

	Display	R5 R4 R3 R2 R1 R0	G5 G4 G3 G2 G1 G0	B5 B4 B3 B2 B1 B0	Gray Scale Level
Basic Color	Black	L L L L L L	L L L L L L	L L L L L L	-
	Blue	L L L L L L	L L L L L L	H H H H H H	-
	Green	L L L L L L	H H H H H H	L L L L L L	-
	Light Blue	L L L L L L	H H H H H H	H H H H H H	-
	Red	H H H H H H	L L L L L L	L L L L L L	-
	Purple	H H H H H H	L L L L L L	H H H H H H	-
	White	H H H H H H	H H H H H H	H H H H H H	-
Gray Scale of Red	Black	L L L L L L	L L L L L L	L L L L L L	L 0
	Dark ↑ ↓ Light	L L L L L H	L L L L L L	L L L L L L	L 1
		L L L L H L	L L L L L L	L L L L L L	L 2
		: :	: :	: :	L3... L60
		H H H H L H	L L L L L L	L L L L L L	L61
		H H H H H L	L L L L L L	L L L L L L	L62
	Red	H H H H H H	L L L L L L	L L L L L L	Red L63
Gray Scale of Green	Black	L L L L L L	L L L L L L	L L L L L L	L 0
	Dark ↑ ↓ Light	L L L L L L	L L L L L H	L L L L L L	L 1
		L L L L L L	L L L L H L	L L L L L L	L 2
		: :	: :	: :	L3... L60
		L L L L L L	H H H H L H	L L L L L L	L61
		L L L L L L	H H H H H L	L L L L L L	L62
	Green	L L L L L L	H H H H H H	L L L L L L	Green L63
Gray Scale of Blue	Black	L L L L L L	L L L L L L	L L L L L L	L 0
	Dark ↑ ↓ Light	L L L L L L	L L L L L L	L L L L L H	L 1
		L L L L L L	L L L L L L	L L L L H L	L 2
		: :	: :	: :	L3... L60
		L L L L L L	L L L L L L	H H H H L H	L61
		L L L L L L	L L L L L L	H H H H H L	L62
	Blue	L L L L L L	L L L L L L	H H H H H H	Blue L63
Gray Scale of White & Black	Black	L L L L L L	L L L L L L	L L L L L L	L 0
	Dark ↑ ↓ Light	L L L L L H	L L L L L H	L L L L L H	L 1
		L L L L H L	L L L L H L	L L L L H L	L 2
		: :	: :	: :	L3... L60
		H H H H L H	H H H H L H	H H H H L H	L61
		H H H H H L	H H H H H L	H H H H H L	L62
	White	H H H H H H	H H H H H H	H H H H H H	White L63

RELIABILITY TEST

TEST CONDITIONS

- 1) The module should be driven and inspected under normal test conditions.
- 2) The module should not have condensation of water (moisture) on the module.
- 3) The module should be inspected after two or more hours storage in normal conditions (15 - 35°C, 45 - 65%(RH)).
- 4) A module shall be used only for one test.

SPECIFICATIONS

The module shall have no failure in the following reliability test items.

Test Item	Test Conditions	Result
High Temperature Operation ¹⁾	65°C 192 h	TBD
High Temperature Storage ²⁾	80°C 192 h	TBD
High Temperature High Humidity operation ¹⁾	50°C 80% 192 h	TBD
Low Temperature Operation ¹⁾	-10°C 192 h	TBD
Low Temperature Storage ²⁾	-20°C 192 h	TBD
Temperature Shock ²⁾	-20°C ⇔ 80°C 0.5h 0.5h 50 cycles	TBD
Mechanical Vibration ²⁾	10 - 200 - 10Hz sweep/cycle, 1.5×9.8m/s ² constant, X.Y.Z each directions, 0.5h each	TBD
Mechanical Shock ²⁾	50×9.8m/s ² , 20ms, ±X, ±Y, ±Z direction, one time each	TBD

Note 1) Operating

Note 2) Non-Operating

Definitions of failure for judgment shall be as follows:

- 1) Function of the module should be maintained.
- 2) Current consumption should be smaller than the specified value.
- 3) Appearance and display quality should not have distinguished degradation.
- 4) Luminance should be larger than 50% of the minimum value specified in OPTICAL SPECIFICATION.

**FOR SAFETY**

LCD module is generally designed with precise parts to achieve light weighted thin mechanical dimensions. In using our Modules, make certain that you fully understand and put into practice the warnings and safety precautions detailed in Engineering Information No.EE-N001,"CAUTIONS AND INSTRUCTIONS FOR TOSHIBA LCD MODULES". Refer to individual specifications and TECHNICAL DATA sheets (hereinafter called "TD") for more detailed technical information.

1) SPECIAL PURPOSES

A) Toshiba Matsushita Display Technology's Standard LCD Modules have not been customized for operation in extreme environments or for use in applications where performance failures could be life-threatening or otherwise catastrophic.

B) Since Toshiba Matsushita Display Technology's Standard LCD Modules have not been designed for operation in extreme environments, they must never be used in devices that will be exposed to abnormally high levels of vibration or shock which exceed Toshiba Matsushita Display Technology's published specification limits.

C) In addition, since Toshiba Matsushita Display Technology Standard LCD Modules have not been designed for use in applications where performance failures could be life-threatening or catastrophic, they must never be installed in aircraft navigation control systems (such as, but not limited to Traffic Collision Avoidance System and Air Traffic Indicator), in military defense or weapons systems, in critical industrial process-control systems (e.g., those involved in the production of nuclear energy), or in critical medical device or patient life-support systems.

2) DISASSEMBLING OR MODIFICATION

DO NOT DISASSEMBLE OR MODIFY the module. It may damage sensitive parts inside LCD module, and may cause scratches or dust on the display.

Toshiba Matsushita Display Technology does not warrant the module, if customer disassembled or modified it.

3) BREAKAGE OF LCD PANEL

DO NOT INGEST liquid crystal material, DO NOT INHALE this material, and DO NOT CONTACT the material with skin, if LCD panel is broken and liquid crystal material spills out.

If liquid crystal material comes into mouth or eyes, rinse mouth or eyes out with water immediately.

If this material contact with skin or cloths, wash it off immediately with alcohol and rinse thoroughly with water.

4) GLASS OF LCD PANEL

BE CAREFUL WITH CHIPS OF GLASS that may cause injuring fingers or skin, when the glass is broken.

5) ELECTRIC SHOCK

DISCONNECT POWER SUPPLY before handling LCD module.

DO NOT TOUCH the parts inside LCD module and the fluorescent lamp's connector or cables in order to prevent electric shock, because high voltage is supplied to these parts from the inverter unit while power supply is turned on.

6) ABSOLUTE MAXIMUM RATINGS AND POWER PROTECTION CIRCUIT

DO NOT EXCEED the absolute maximum rating values under the worst probable conditions caused by the supply voltage variation, input voltage variation, variation in parts' constants, environmental temperature, etc., otherwise LCD module may be damaged.

Employ protection circuit for power supply, whenever the specification or TD specifies it.

Suitable protection circuit should be applied for each system design.

7) DISPOSAL

When dispose LCD module, obey to the applicable environmental regulations.