

FEATURES

- (1) a-Si TFT-LCD for portable DVD.
- (2) Analog RGB input.
- (3) High luminance & wide viewing angle.
- (4) Slim, thin, and light weight design.

TENTATIVE

GENERAL SPECIFICATIONS

Items	Specifications	Note
Screen size	18cm (7-Type) diagonal screen	
Display mode	TN full color, Transmissive type	Normally white
Contents	TFT-cell, Driver-ICs, Backlight-unit	
Viewing direction	6 o'clock (in direction of maximum CR)	Refer to figure A (Next sheet)
Driving method	a-Si TFT active matrix, Line sequential scanning Non-Interlace drive	
Input signal	Sync.	Horizontal/Vertical start pulse and clock Vertical (gate) enable
	Signal	Specified analog RGB signals (H-line inverted)
	Common	H-line alternate signal
Number of pixels	480(W) x 234(H)	Note 1
Number of sub-pixels	1440(W) x 234(H)	Note 1
Pixel pitch	0.321(W) x 0.370(H)	[unit: mm]
Pixel arrangement	RGB stripe	Note 1
Dimensional outline	166.0(W) x 100.0(H) x 7.0(D) (typ.)	[unit: mm]
Active area	154.08 (W) x 86.58 (H)	[unit: mm]
Backlight	FL side light (L type 1 lamp)	
Surface treatment	Anti-glare coating on LCD panel surface. Wide view film	
Weight	175 (typ.)	[unit: g]

Note 1: Pixel arrangement

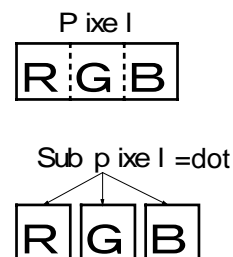
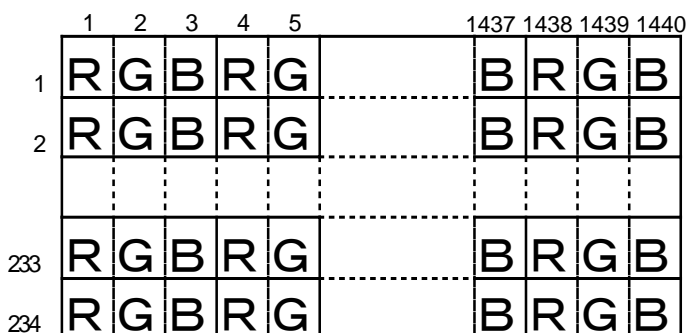

*The information contained herein is presented only as a guide for the applications of our products. No responsibility is assumed by Toshiba Matsushita Display Technology Co., Ltd. or other rights of the third parties which may result from its use. No license is granted by implication or otherwise under any patent or patent rights of Toshiba Matsushita Display Technology Co., Ltd. or others.

*The information contained herein may be changed without prior notice. It is therefore advisable to contact Toshiba Matsushita Display Technology Co., Ltd. before proceeding with the design of equipment incorporating this product.

Figure A: Viewing direction

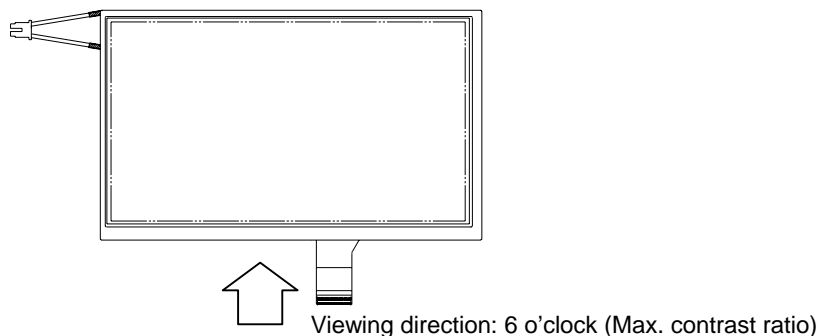
**ABSOLUTE MAXIMUM RATINGS** (Note 1)

Items		Symbol	Conditions	Min.	Max.	Unit	Remarks
Supply voltage		VDD	Ta=25°C	-0.3	6.5	V	
		VEE	Ta=25°C	-0.3	6.5	V	
		VGON	Ta=25°C	-0.3	45.0	V	VSS=0
		VSS	Ta=25°C	VGON-45.0	VGON+0.3	V	
		VFL	Ta=25°C	-	3000	V(rms)	
Input signal voltage	Analog	VANA	Ta=25°C	-0.3	VEE+0.3	V	Note 4
	Logic	VIN	Ta=25°C	-0.3	VDD+0.3	V	Note 5
	Common	VCOM	Ta=25°C	-10.0	13.0	V	
Operating temperature		Top	-	-20	70	°C	Note 2, 3
Operating humidity		Hop	-	-	90	%(RH)	
Storage temperature		Tstg	-	-30	80	°C	Note 3
Storage humidity		Hstg	-	-	95	%(RH)	

Note 1: Do not exceed the maximum rating values under the worst probable conditions taking into account the supply voltage variation, input voltage variation, variation in part constants, and ambient temperature and so on. Otherwise the module may be damaged.

Note 2: The temperature of the module rises under the influence of the backlight. Please design that all parts of this module do not to exceed maximum operation temperature (Top).

Note 3: The temperature on TFT-LCD panel surface.

Note 4: Terminals; VB, R, G, B

Note 5: Terminals; CLK1, CLK2, CLK3, STH1, STH2, OEH, MODE, RL, CPV, STV1, STV2, OEV1, OEV2, OEV3, U/D

CIRCUIT BLOCK DIAGRAM

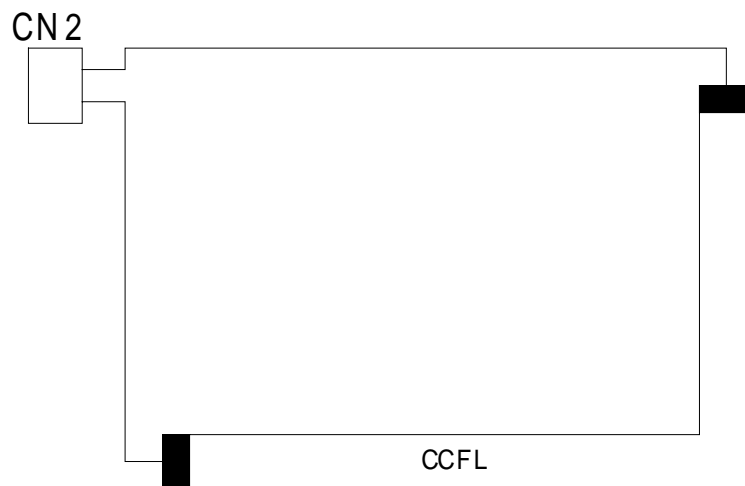
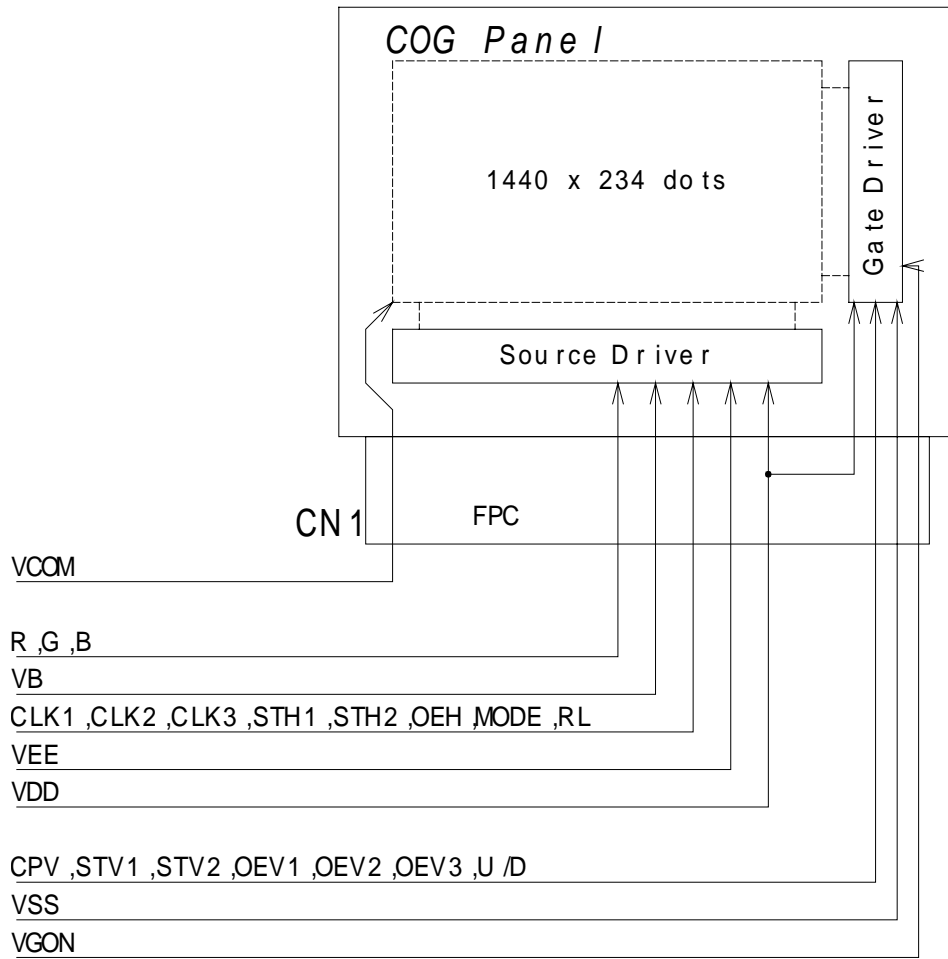

VIDEO SIGNAL TIMING CHART

NTSC (Full scan mode)

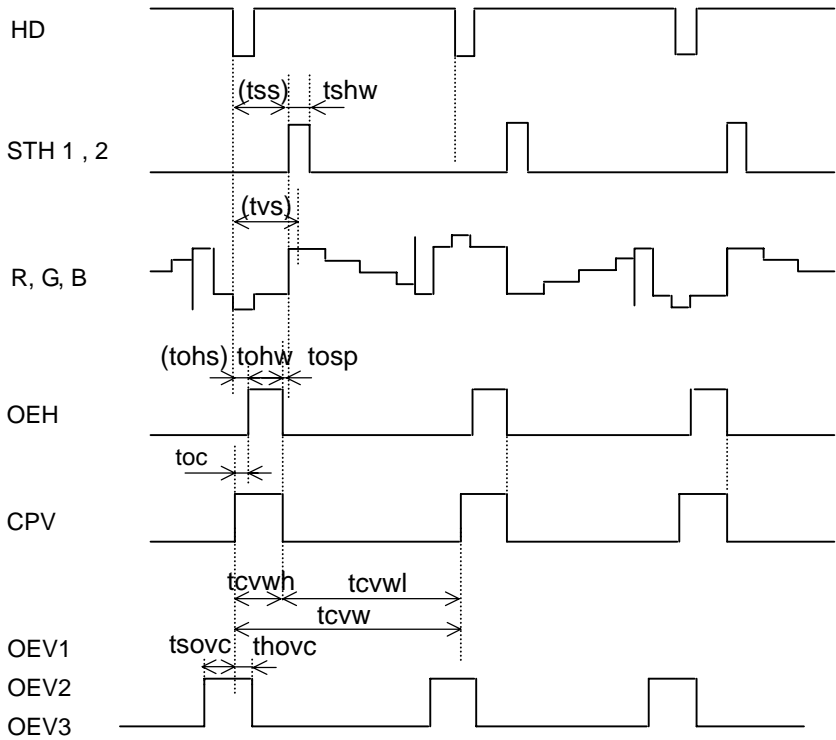
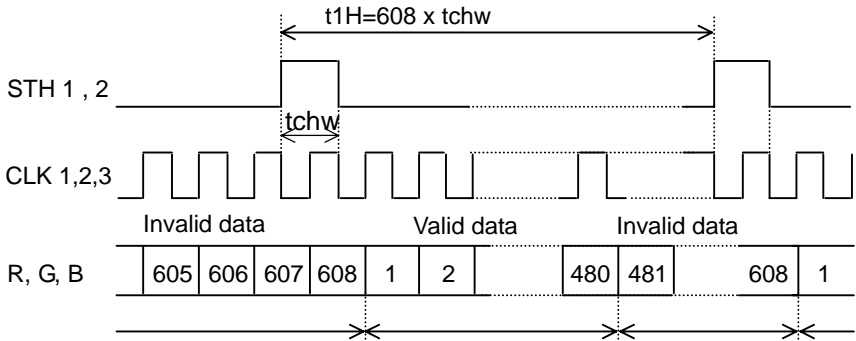
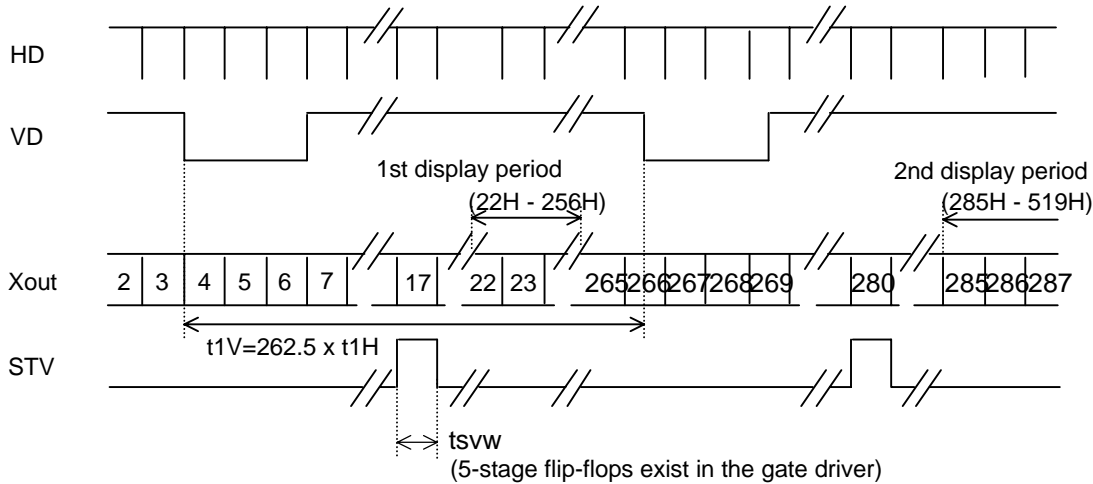

Note: At the time of a power on sequence, OEV should hold on "Hi" at least 1 frame period (t1V), after STV and CPV are inputted.

CONTROL SIGNAL TIMING CHART

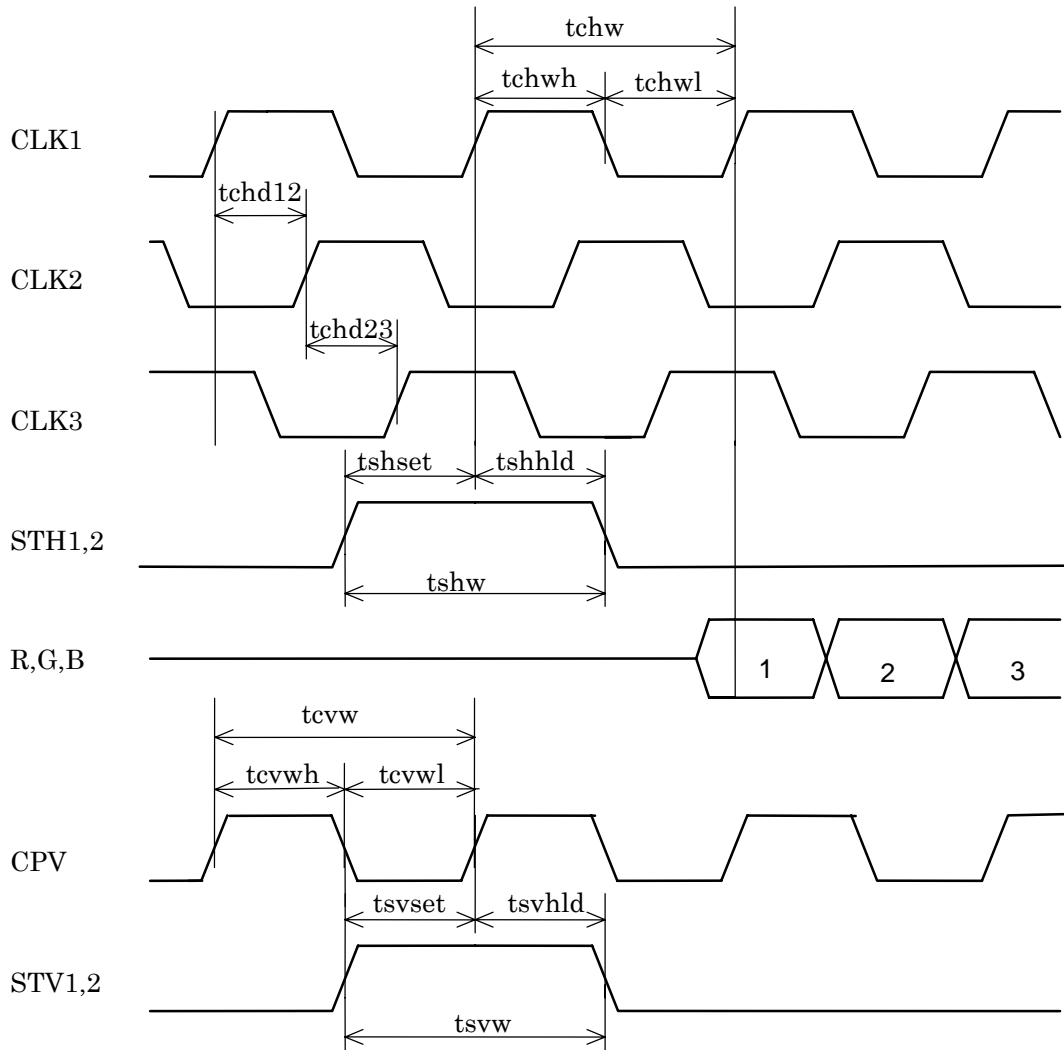

TIMING SPECIFICATION

NTSC (Full scan mode)

Signal	Parameter	Symbol	Min.	Typ.	Max.	Unit	Remarks
	Frame frequency	1/t1v	57.143	59.939	62.852	Hz	
	Frame period	t1V	262.5 x t1H	262.5 x t1H	262.5 x t1H	-	
	1 Line scanning period	t1H	608 x tchw 60.6	608 x tchw 63.5	608 x tchw 66.6	- μs	
CLK1, CLK2, CLK3	Period	tchw	100.0	104.6	108.6	ns	
	Frequency	1/tchw	9.20	9.56	9.95	MHz	
	Pulse delay	tchd	31.4	34.9	38.4	ns	tchd12,tchd23
	Pulse width (Hi)	tchwh	47.1	52.3	57.5	ns	
	Pulse width (Lo)	tchwl	47.1	52.3	57.5	ns	
STH1, STH2	Rising of STH to HD	tss	1.45	9.85	10.96	μs	Reference value
	Pulse width	tshw	30.0	104.6	208.0*	ns	*tshset=tshhld
	Setup	tshset	10.0	52.3	-	ns	
	Hold	tshhld	20.0	52.3	-	ns	
R,G,B	Video input to HD	tvS	1.59	10.00	11.11	μs	Reference value
OEH	Rising of OEH to HD	tohs	-	1.4	1.9	μs	Reference value
	Falling of OEH to STH	tosp	0.0	0.5	-	μs	
	Pulse width	tohw	7.5	8.0	8.5	μs	
CPV	Period	tcvw	10.0	63.5	-	μs	
	Rising of CPV to OEH	toc	1.5	2.3	-	μs	
	Pulse width (Hi)	tcvwh	5.0	10.3	58.5	μs	
	Pulse width (Lo)	tcvwl	5.0	53.2	58.5	μs	
OEV1, OEV2, OEV3,	Rising of OEV to CPV	tsovc	1.0	1.5	2.0	μs	
	Falling of OEV to CPV	thovc	2.0 x tchw	3.0 x tchw	4.0 x tchw	-	
STV1, STV2	Pulse width	tsvw	5.0	63.5	126.0**	μs	**tsvset=tsvhld
	Setup	tsvset	2.00	31.75	-	μs	
	Hold	tsvhld	2.00	31.75	-	μs	

INTERFACE PIN ASSIGNMENT

CN1: INPUT SIGNAL

FPC: 0.5mm pitch

Mating connector: IL-FPR series/Japan Aviation Electronics Industry, Limited

Pin No.	Symbol	Functions	Remarks
1	VCOM	Voltage applied to color filter substrate	
2	STH1	Source scanning start signal 1	Note 2
3	VB	Source output current adjustment	
4	R	Red video signal	
5	G	Green video signal	
6	B	Blue video signal	
7	OEH	Source driver output enable	
8	VDD	Power line for logic (3.3V)	
9	MODE	Sampling mode change (H: Simultaneous, L: Sequential)	Note 3
10	CLK1	Source driver clock input 1	Note 3
11	CLK2	Source driver clock input 2	Note 3
12	CLK3	Source driver clock input 3	Note 3
13	RL	Right / Left scanning change	Note 2
14	STH2	Source scanning start signal 2	Note 2
15	VEE	Power line for source driver IC (5.0V)	
16	GND	Ground (0V)	
17	VCOM	Voltage applied to color filter substrate	
18	STV2	Gate scanning start signal 2	Note 1
19	OEV3	Gate driver output enable 3	
20	OEV2	Gate driver output enable 2	
21	OEV1	Gate driver output enable 1	
22	CPV	Gate driver scanning clock pulse	
23	U/D	Up/Down scanning change	Note 1
24	STV1	Gate scanning start signal 1	Note 1
25	NC	Non connect	
26	VSS	Gate driver negative voltage (-13.0V)	
27	GND	Ground (0V)	
28	VDD	Power line for logic (3.3V)	
29	NC	Non connect	
30	VGON	Gate driver positive voltage (17.0V)	

CN2: CCFL POWER SOURCE

Connector: BHSR-02VS-1 / J.S.T. Mfg. Co., Ltd.

Mating connector: SM02B-BHSS-1 / J.S.T. Mfg. Co., Ltd.

No.	Symbol	Functions	I/O	Remarks
1	V _{FLL}	FL power supply for backlight (GND)	Input	White
2	V _{FLH}	FL power supply for backlight (HOT)	Input	Red

Note 1: Switch scanning direction of UP/DOWN as follows:

	UD	STV1	STV2	Remarks
Up to down	Lo	Output	Input	usual
Down to up	Hi	Input	Output	

Up to down

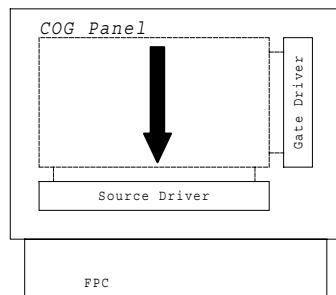

Down to up

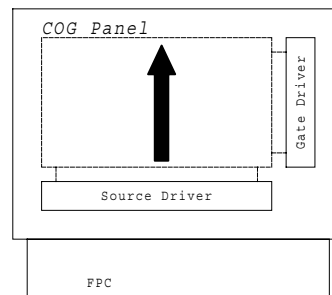

Note 2: Switch scanning direction of RIGHT/LEFT as follows:

	RL	STH1	STH2	Remarks
Left to right	Hi	Input	Output	usual
Right to left	Lo	Output	Input	

Left to right

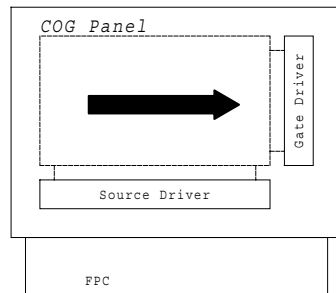

Right to left

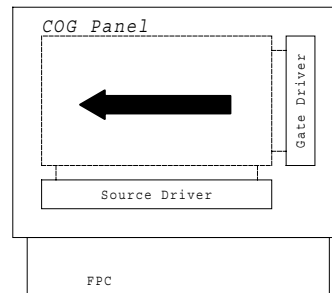

Note 3: Set source sampling mode as follows:

	MODE	CLK1	CLK2	CLK3
Sequential sampling	Lo	Input	Input	Input
Synchronous sampling	Hi	Input	Hi	Hi

SEQUENCE FOR POWER ON/OFF AND SIGNAL ON/OFF

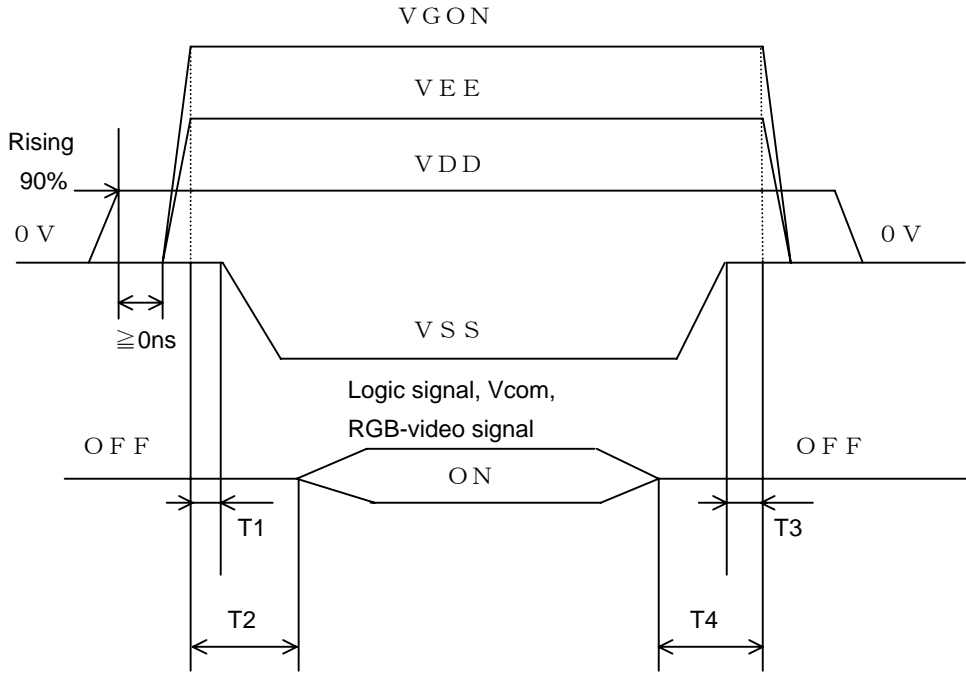

- 1) $10\text{ms} \leq T1 < T2, 0 < T3 < T4 \leq 10\text{ms}$
- 2) Please use the schottky barrier diode as follows;

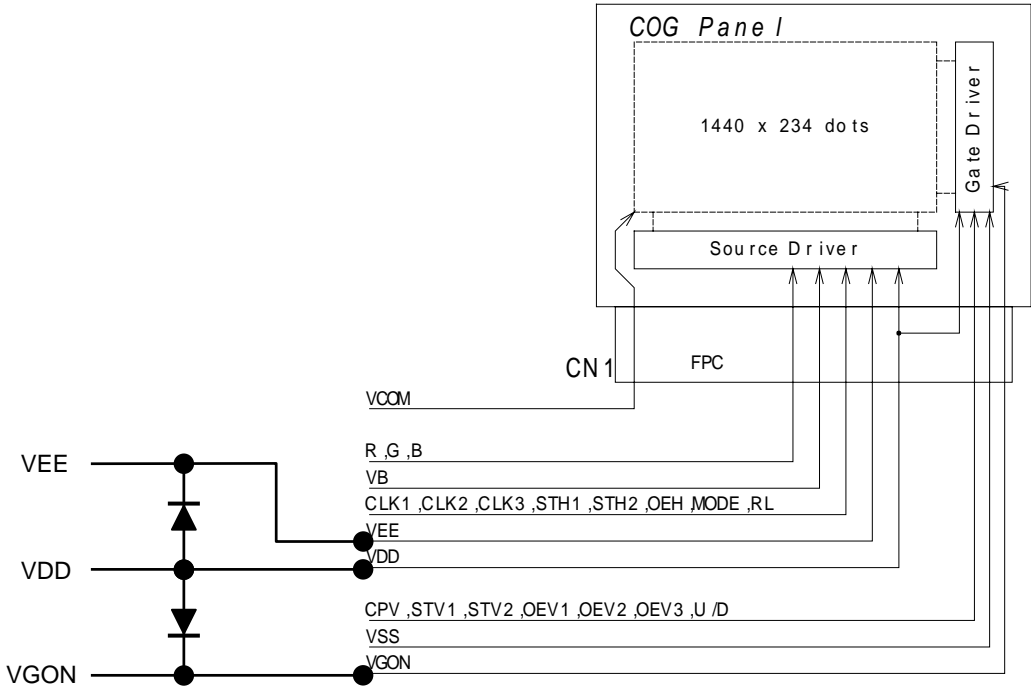

ELECTRICAL SPECIFICATION (Ta=25°C) (RECOMMENDED OPERATING CONDITION) (Note 1)

Items		Symbol	Min.	Typ.	Max.	Unit	Remarks
Supply voltage		VDD	2.7	3.3	3.6	V	
		VEE	4.5	5.0	5.5	V	
		VGON	16.0	17.0	18.0	V	
		VSS	-14.0	-13.0	-12.0	V	
		V _{FL}	-	600	-	V(rms)	I _{FL} =6.5mA(rms) Note 2
Source output current adjustment		VB	1.8	2.0	2.2	V	VEE=-5.0V VSPP=3.5V VCPP=7.0V
Input signal voltage	Logic low level	VIL	0.0	-	0.2 x VDD	V	
	Logic high level	VIH	0.80 x VDD	-	VDD	V	
	Video black (+)	VSB+	(0.20)	0.75	(VSW+)	V	R,G,B, VEE=-5.0V Note 3
	Video white (+)	VSW+	(VSB+)	4.25	(4.80)	V	R,G,B, VEE=-5.0V Note 3
	Video black (-)	VSB-	(VSW-)	4.25	(4.80)	V	R,G,B, VEE=-5.0V Note 3
	Video white (-)	VSW-	(0.20)	0.75	(VSB-)	V	R,G,B, VEE=-5.0V Note 3
	Video amplitude	VSPP	-	3.5	VEE-0.4	V(p-p)	R,G,B Note 3
	Video center	VSC	2.3	VEE/2	2.7	V	R,G,B Note 3
	VCOM amplitude	VCPP	3.0	7.0	9.0	V(p-p)	Note 3
	VCOM center	VCOMC	-0.5	0.5	1.5	V	Note 3, Note 4
	(VSPP+VCPP)/2	-	-	-	5.5	V	Note 3
FL driving frequency		f _{FL}	30	40	80	kHz	Note 5
FL starting voltage		V _{SFL}	1900	-	-	V(rms)	-20°C Note 6
Supply current		IDD	-	1.79	3.60	mA	VDD=3.3V Note 7
		IEE	-	19.60	39.20	mA	VEE=-5.0V, VB=2.0V, Note 7
		IGH	-	0.12	1.00	mA	VGON=17.0V Note 7
		ISS	-1.00	-0.30	-	mA	VSS=-13.0V Note 7
		I _{FL}	3.0	6.5	7.0	mA(rms)	

Note 1 : The recommended operating conditions show the ranges in which the device can operate normally. Operation beyond the limit of the recommended operating conditions is not assured, even though operating conditions are within the limit of the absolute maximum ratings.

Note 2: FL input current values are reference.

Note 3: R, G, B and VCOM should be inverted every 1H as follows (an example of input timing).

VCOM driving circuit should be designed with 50Ω or less output impedance.

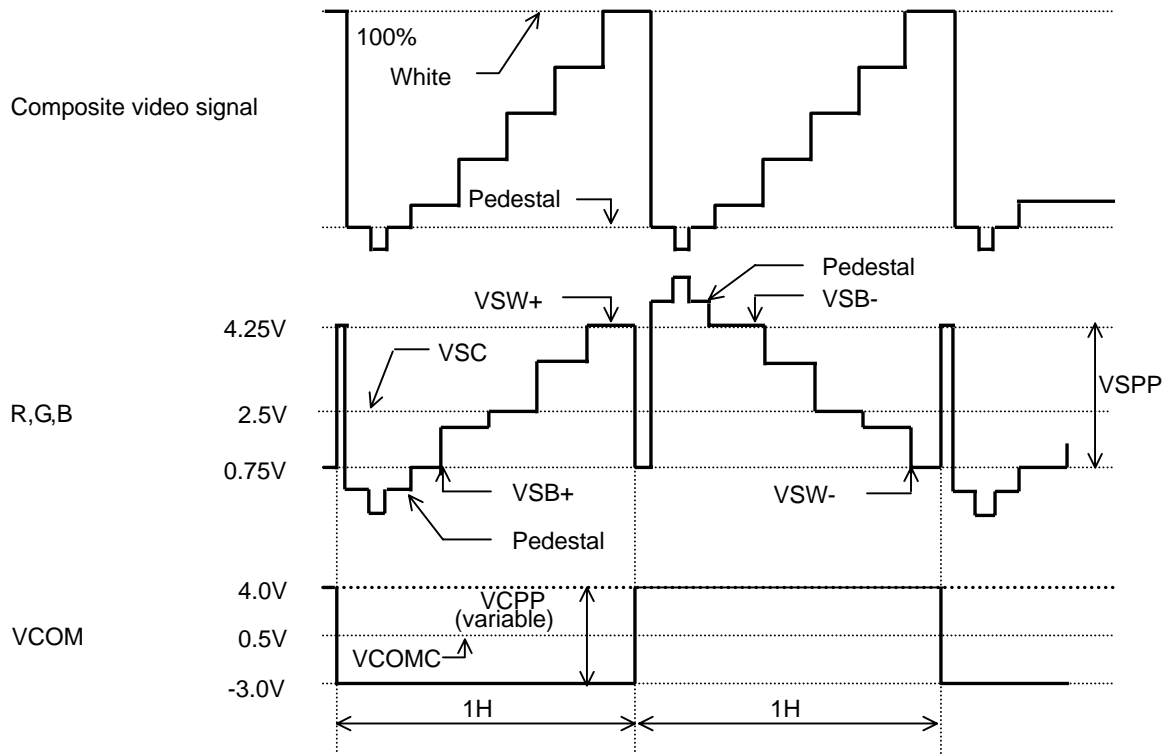

Note 4: Adjust for minimum flicker.

Note 5: Recommended for Horizontal frequency: 40.0kHz

Note 6: Initial value.

Note 7: Not peak current value but continuous one.

OPTICAL SPECIFICATION ($T_a=25^{\circ}\text{C}$)

Characteristics	Symbol	Condition			Standard value			Unit	Measuring method
		θ	ϕ	C.	MIN.	TYP.	MAX.		
Luminance	L	0°	0°	/	300	400	-	cd/m ²	$I_{FL}=6.5\text{mA(rms)}$
Contrast ratio	Cmax	best angle			100	300	-	-	
White color chromaticity	x	0°	0°	/	0.275	0.315	0.355	-	
	y	0°	0°	/	0.300	0.340	0.380	-	
Brightness uniformity	-	0°	0°	/	0.7	-	-	-	
Vertical viewing angle	θ_U	-	0°	≥ 10	20	30	-	°	
	θ_D	-	0°	≥ 10	40	60	-	°	
Horizontal viewing angle	ϕ_L	0°	-	≥ 10	45	60	-	°	
	ϕ_R	0°	-	≥ 10	45	60	-	°	
Response time	τ_r	0°	0°	/	-	11	22	ms	
	τ_d	0°	0°	/	-	22	44	ms	
Backlight life	-	-	-	-	(10000)	-	-	h	Continuous lighting Note 1

Note 1: Period till Brightness falls 50% from the initial value. Reference value at continuous lighting.

**FOR SAFETY**

LCD module is generally designed with precise parts to achieve light weighted thin mechanical dimensions. In using our Modules, make certain that you fully understand and put into practice the warnings and safety precautions detailed in Engineering Information No.EE-N001,"CAUTIONS AND INSTRUCTIONS FOR TOSHIBA LCD MODULES". Refer to individual specifications and TECHNICAL DATA sheets (hereinafter called "TD") for more detailed technical information.

1) SPECIAL PURPOSES

A) Toshiba's Standard LCD Modules have not been customized for operation in extreme environments or for use in applications where performance failures could be life-threatening or otherwise catastrophic.

B) Since Toshiba's Standard LCD Modules have not been designed for operation in extreme environments, they must never be used in devices that will be exposed to abnormally high levels of vibration or shock which exceed Toshiba's published specification limits.

C) In addition, since Toshiba Standard LCD Modules have not been designed for use in applications where performance failures could be life-threatening or catastrophic, they must never be installed in aircraft navigation control systems (such as, but not limited to Traffic Collision Avoidance System and Air Traffic Indicator), in military defense or weapons systems, in critical industrial process-control systems (e.g., those involved in the production of nuclear energy), or in critical medical device or patient life-support systems.

2) DISASSEMBLING OR MODIFICATION

DO NOT DISASSEMBLE OR MODIFY the module. It may damage sensitive parts inside LCD module, and may cause scratches or dust on the display.

Toshiba does not warrant the module, if customer disassembled or modified it.

3) BREAKAGE OF LCD PANEL

DO NOT INGEST liquid crystal material, DO NOT INHALE this material, and DO NOT CONTACT the material with skin, if LCD panel is broken and liquid crystal material spills out.

If liquid crystal material comes into mouth or eyes, rinse mouth or eyes out with water immediately.

If this material contact with skin or cloths, wash it off immediately with alcohol and rinse thoroughly with water.

4) GLASS OF LCD PANEL

BE CAREFUL WITH CHIPS OF GLASS that may cause injuring fingers or skin, when the glass is broken.

5) ELECTRIC SHOCK

DISCONNECT POWER SUPPLY before handling LCD module. DO NOT TOUCH the parts inside LCD module in order to prevent electric shock, because high voltage is supplied to these parts while power supply is turned on.

6) ABSOLUTE MAXIMUM RATINGS AND POWER PROTECTION CIRCUIT

DO NOT EXCEED the absolute maximum rating values under the worst probable conditions caused by the supply voltage variation, input voltage variation, variation in parts' constants, environmental temperature, etc., otherwise LCD module may be damaged.

Employ protection circuit for power supply, whenever the specification or TD specifies it.

Suitable protection circuit should be applied for each system design.

7) DISPOSAL

When dispose LCD module, obey to the applicable environmental regulations.

