

PRODUCT INFORMATION

LTA065A041F
(a-Si TFT)

【feature】

TENTATIVE

- (1) a-Si TFT-LCD, USE:FA, AMS
- (2) 640(W) x 3(RGB) x 480(H) vertical stripes, Highly minute
- (3) "Transmitting type", High brightness, High contrast, Wide view angle
- (4) Digital 6 bit RGB input interface
- (5) COG(Chip On Glass) composition
- (6) LCD drive circuit is built in, but inverter for backlight is not built in.

【Mechanical Specification】

| CHARACTERISTIC ITEM | SPECIFICATION |
|-------------------------------------|---------------------------------------------|
| Module outer dimension (TYP.) note1 | 151.0 (W) x 115.5 (H) x 10.0 (D) mm |
| Number of dots | 640 (W) x 3 (RGB) x 480 (H) |
| Color-filter-array | RGB vertical stripes |
| Pitch of dots | 0.0685 (W) x 0.2055 (H) |
| Effective display area | 131.52 (W) x 98.64 (H) mm |
| Gray scales | 64 |
| Front surface treatment | AG coat (with WV film) |
| Backlight | CCFL with 3 wave-length spectrum (L-type) |
| Consumption power note2 | 4.2 W |
| Weight (TYP.) | 205 g |

note1...The lug (FPC, lump harness and connector) is not included.

note2...The loss of inverter efficiency is not included.

【Environmental Conditions Specification】

| ITEM | CONDITION | SPECIFICATION | REMARK |
|-----------------|---------------|---------------|--------|
| Operating Temp. | Panel surface | -10 ~ 60°C | note1 |
| Storage Temp. | Panel surface | -20 ~ 70°C | |

note1...This value guarantees only operation, but doesn't guarantee all the contents of Electro-optical specification.

Electro-optical specification can be guaranteed at the condition that ambient temperature is 25°C.

【Electro-optical Specification (Ta=25°C)】

| CHARACTERISTICS | SYMBOL | CONDITION | | | STANDARD VALUE | | | UNIT | REMARK |
|-----------------------------|------------|------------|--------|-----------|----------------|-------|-------|-------------------|--------|
| | | θ | ϕ | C | MIN. | TYP. | MAX. | | |
| (1)Brightness | B | 0° | 0° | - | 300 | 400 | - | cd/m ² | note1 |
| | | | | | 240 | 340 | - | cd/m ² | note2 |
| (2)Contrast Ratio | Cmax | Best Angle | | | 100 | 250 | - | - | |
| (3)White color chromaticity | X | 0° | 0° | - | 0.270 | 0.310 | 0.350 | - | |
| | Y | 0° | 0° | - | 0.280 | 0.320 | 0.360 | - | |
| (4)Brightness uniformity | - | 0° | 0° | - | 0.7 | - | - | - | |
| (5)Vertical viewing Angle | θ U | - | 0° | ≥ 10 | 40 | 60 | - | ° | note3 |
| | θ D | - | 0° | ≥ 10 | 20 | 30 | - | ° | |
| (6)Horizontal Viewing Angle | Φ L | 0° | - | ≥ 10 | 45 | 60 | - | ° | |
| | Φ R | 0° | - | ≥ 10 | 45 | 60 | - | ° | |
| (7)Response Time | τ r | 0° | 0° | - | - | 10 | 20 | ms | |
| | τ d | 0° | 0° | - | - | 15 | 30 | ms | |

note1...Fluorescent lamp current is 7.0mA.

note2...Fluorescent lamp current is 6.0mA.

note3...The reversal direction is 12 o' clock.

*The information contained herein is presented only as a guide for the applications of our products. No responsibility is assumed by Toshiba Matsushita Display Technology Co.,Ltd. or other rights of the third parties which may result from its use. No license is granted by implication or otherwise under any patent or patent rights of Toshiba Matsushita Display Technology Co.,Ltd. or others.

*The information contained herein may be changed without prior notice. It is therefore advisable to contact Toshiba Matsushita Display Technology Co.,Ltd. before proceeding with the design of equipment incorporating this product.

【Interface】

Signal interface (CN1)

Use Connector: IL-FHR-B40S-HF (0.5 mm pitch 40 pin Solder plating processing) (JAE)

| Pin No. | SYMBOL | FUNCTION | Comment |
|---------|--------|----------------------------------------|------------------------------------------------|
| 1 | VDD | +3.3V Power Supply | |
| 2 | VDD | +3.3V Power Supply | |
| 3 | VDD | +3.3V Power Supply | |
| 4 | VDD | +3.3V Power Supply | |
| 5 | GND | Signal Ground | |
| 6 | GSX1 | Display period compensation signal | It opens, when performing the usual operation. |
| 7 | GND | Signal Ground | |
| 8 | DOFF1 | Non-display period compensation signal | It opens, when performing the usual operation. |
| 9 | GND | Signal Ground | |
| 10 | DE | Data Enable Signal | |
| 11 | GND | Signal Ground | |
| 12 | VS | Vertical Sync. | |
| 13 | GND | Signal Ground | |
| 14 | HS | Horizontal Sync. | |
| 15 | GND | Signal Ground | |
| 16 | B5 | Blue Data | Blue picture display data |
| 17 | B4 | Blue Data | |
| 18 | B3 | Blue Data | |
| 19 | B2 | Blue Data | |
| 20 | B1 | Blue Data | |
| 21 | B0 | Blue Data | |
| 22 | GND | Signal Ground | |
| 23 | G5 | Green Data | Green picture display data |
| 24 | G4 | Green Data | |
| 25 | G3 | Green Data | |
| 26 | G2 | Green Data | |
| 27 | G1 | Green Data | |
| 28 | G0 | Green Data | |
| 29 | GND | Signal Ground | |
| 30 | R5 | Red Data | Red picture display data |
| 31 | R4 | Red Data | |
| 32 | R3 | Red Data | |
| 33 | R2 | Red Data | |
| 34 | R1 | Red Data | |
| 35 | R0 | Red Data | |
| 36 | GND | Signal Ground | |
| 37 | GND | Signal Ground | |
| 38 | CLK | Dot Clock | Pick up each signal at negative edge |
| 39 | GND | Signal Ground | |
| 40 | GND | Signal Ground | |

【Absolute Maximum Ratings】

| CHARACTERISTICS | SYMBOL | CONDITION | MIN. | MAX. | UNIT | REMARKS |
|---------------------------------------------|--------|-----------|------|---------|--------|---------|
| Logic voltage | VI | Ta=25°C | -0.3 | 4.5 | V | |
| Supply voltage | VDD | Ta=25°C | -0.3 | VDD+0.3 | V | |
| Back light input voltage | - | - | - | 3000 | Vrms | |
| Storage temperature (at panel surface) | Tstg | - | -20 | 70 | °C | |
| Storage Humidity (at panel surface) | Hstg | - | 10 | 90 | % (RH) | |

【Electrical Specification】

| CHARACTERISTICS | | SYMBOL | MIN. | TYP. | MAX. | UNIT | REMARKS |
|--------------------------|---------------------|--------|-------------|-------|-------------|-------|---------|
| Power Voltage | input voltage | VDD | +3.15 | +3.30 | +3.45 | V | |
| | Current consumption | IDD | — | 240 | 350 | mArms | note 1 |
| Input low voltage | | VIL | 0.0 | — | $0.3 * VDD$ | V | |
| Input high voltage | | VIH | $0.7 * VDD$ | — | VDD | V | |
| Allowable Ripple voltage | | VRP | — | — | 100 | mVp-p | |

note1…Effective value (mArms) at VDD=3.3V

Typical value under 8-color-bar displaying condition.

Please consult, when there is inrush current exceeding 500mA at the time of a power supply injection.

● Sequence for Power-on/off and signal on/off

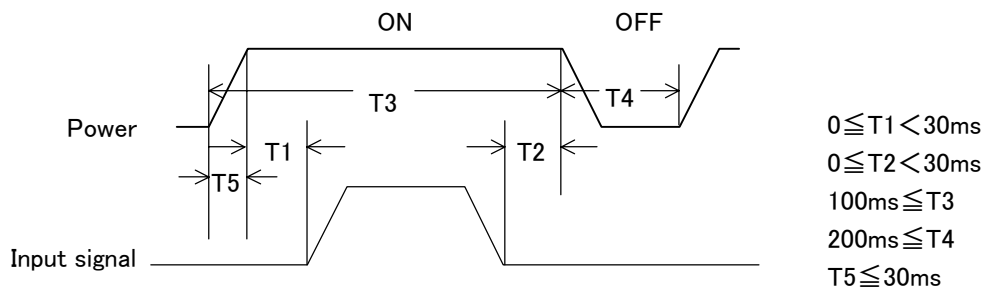

note…The time regulations from T1 to T5 are defined as a changing point 10% of the amplitude of “Input signal“ and “Power”, and 90%.

● In case handling

Make sure to turn off the power when you plug the cable to the input connector and pull the cable out from the connector.

【Electrical Specification (continuation)】

●Timing characteristics of input signals

| Characteristics | | SYMBOL | MIN. | TYP. | MAX. | PAL Drive note 1 | UNIT | REMARKS |
|-----------------------------------------------------|----------------|--------|------|--------|------|---------------------|------|---------|
| CLK Clock | frequency | Fck | — | 25.175 | — | 25.175 | MHz | |
| | Period | Clk | — | 39.72 | — | 39.72 | us | |
| | High Time | Tch | 12 | — | — | MIN : 12 | ns | |
| | Low Time | Tcl | 12 | — | — | MIN : 12 | ns | |
| DATA Data | Setup Time | Tds | 5 | — | — | MIN : 5 | ns | |
| | Hold Time | Tdh | 10 | — | — | MIN : 10 | ns | |
| DE Data Enable | Setup Time | Tes | 5 | — | — | MIN : 5 | ns | |
| | Hold Time | Teh | 10 | — | — | MIN : 10 | ns | |
| Hs Horizontal Sync. | Setup Time | Ths | 5 | — | — | MIN : 5 | ns | |
| | Hold Time | Thh | 10 | — | — | MIN : 10 | ns | |
| | Period | Th | 700 | 800 | 832 | 800 | clk | |
| | Pulse Width | Thp | 4 | 96 | — | 96 | clk | |
| | Front Porch | Thf | — | 13 | — | 13 | clk | |
| | Back Porch | Thb | 7 | 51 | — | 51 | clk | |
| Vs Vertical Sync. | Period | Tv | 516 | 525 | 534 | 625 | th | |
| | | | 16.2 | 16.7 | 17.6 | 19.875 | ms | |
| | Pulse Width | Tvp | 1 | 2 | — | 2 | th | |
| | Front Porch | Tvf | — | 11 | — | 25 | th | |
| | Back Porch | Thb | 4 | 32 | — | 38 | th | |
| GSX1 Display period correction signal | Start Position | Thgs | — | — | — | 738 | clk | note 2 |
| | Pulse Width | Thgsw | — | — | — | 990 | clk | |
| DOFF1 Non-display period correction signal | Start Position | Thdo | — | — | — | 800 | clk | note 2 |
| | Pulse Width | Thdow | — | — | — | 800 | clk | |

The timing of a clock signal is defined by the connector input terminal part.

note 1…PAL drive does not guarantee about the timing which does not follow above.

A flicker and quality of image may deteriorate a little by PAL drive. Please include in your set and check enough.

note 2…The start position of each correction signal is defined as the regulation from falling of DE signal before 1Hs of DE signal removed.

【Electrical Specification(continuation)】

- Timing diagram (PAL drive)

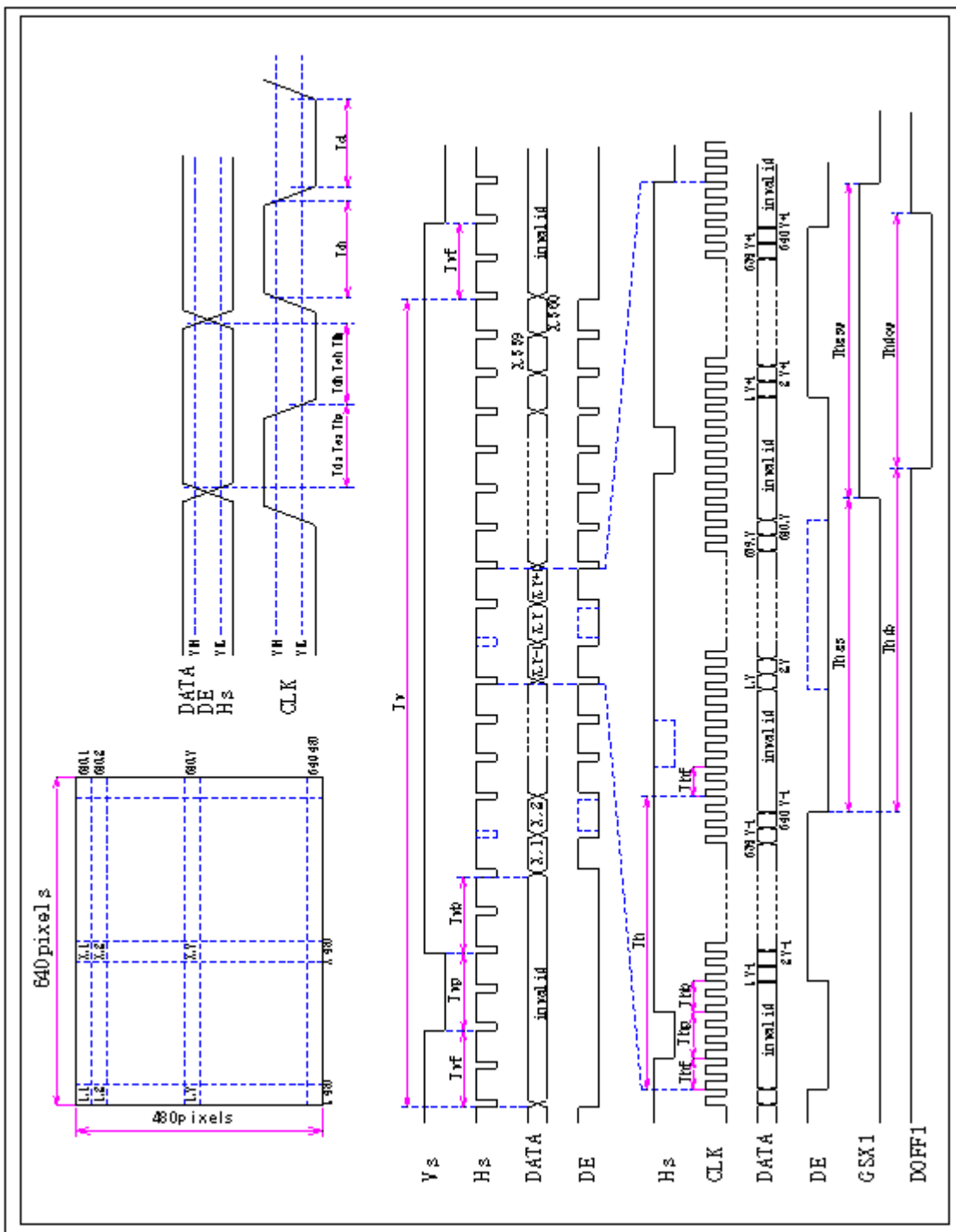

note...DE Signal is defined as above timing concerning to the sync. signal of Vs and Hs. This LCD module is designed to be synchronized only by DE signal even when Vs and Hs are inputted. Therefore, make DE signal be low level by all means for the blanking period that effective data aren't inputted

【Electrical Specification(continuation)】

● Input signal and display color, gray scale

| | Display | Data Signal(0:Low level 1:High level) | | | | | | | | | | | | | | | | | |
|---------------------|--------------|---------------------------------------|----|----|----|----|----|----|----|----|----|----|----|----|----|----|----|----|----|
| | | R5 | R4 | R3 | R2 | R1 | R0 | G5 | G4 | G3 | G2 | G1 | G0 | B5 | B4 | B3 | B2 | B1 | B0 |
| Basic color | Black | 0 | 0 | 0 | 0 | 0 | 0 | 0 | 0 | 0 | 0 | 0 | 0 | 0 | 0 | 0 | 0 | 0 | 0 |
| | Blue | 0 | 0 | 0 | 0 | 0 | 0 | 0 | 0 | 0 | 0 | 0 | 0 | 1 | 1 | 1 | 1 | 1 | 1 |
| | Red | 1 | 1 | 1 | 1 | 1 | 1 | 0 | 0 | 0 | 0 | 0 | 0 | 0 | 0 | 0 | 0 | 0 | 0 |
| | Purple | 1 | 1 | 1 | 1 | 1 | 1 | 0 | 0 | 0 | 0 | 0 | 0 | 1 | 1 | 1 | 1 | 1 | 1 |
| | Green | 0 | 0 | 0 | 0 | 0 | 0 | 1 | 1 | 1 | 1 | 1 | 1 | 0 | 0 | 0 | 0 | 0 | 0 |
| | Light blue | 0 | 0 | 0 | 0 | 0 | 0 | 1 | 1 | 1 | 1 | 1 | 1 | 1 | 1 | 1 | 1 | 1 | 1 |
| | Yellow | 1 | 1 | 1 | 1 | 1 | 1 | 1 | 1 | 1 | 1 | 1 | 1 | 0 | 0 | 0 | 0 | 0 | 0 |
| | White | 1 | 1 | 1 | 1 | 1 | 1 | 1 | 1 | 1 | 1 | 1 | 1 | 1 | 1 | 1 | 1 | 1 | 1 |
| Gray scale of red | Black | 0 | 0 | 0 | 0 | 0 | 0 | 0 | 0 | 0 | 0 | 0 | 0 | 0 | 0 | 0 | 0 | 0 | 0 |
| | Dark | 0 | 0 | 0 | 0 | 0 | 1 | 0 | 0 | 0 | 0 | 0 | 0 | 0 | 0 | 0 | 0 | 0 | 0 |
| | ↑ | 0 | 0 | 0 | 0 | 1 | 0 | 0 | 0 | 0 | 0 | 0 | 0 | 0 | 0 | 0 | 0 | 0 | 0 |
| | ⋮ | | | | : | | | | | | | | | | | | : | | |
| | ↓ | 1 | 1 | 1 | 1 | 0 | 1 | 0 | 0 | 0 | 0 | 0 | 0 | 0 | 0 | 0 | 0 | 0 | 0 |
| | Bright Red | 1 | 1 | 1 | 1 | 1 | 0 | 0 | 0 | 0 | 0 | 0 | 0 | 0 | 0 | 0 | 0 | 0 | 0 |
| Gray scale of green | Black | 0 | 0 | 0 | 0 | 0 | 0 | 0 | 0 | 0 | 0 | 0 | 0 | 0 | 0 | 0 | 0 | 0 | 0 |
| | Dark | 0 | 0 | 0 | 0 | 0 | 0 | 0 | 0 | 0 | 0 | 1 | 0 | 0 | 0 | 0 | 0 | 0 | 0 |
| | ↑ | 0 | 0 | 0 | 0 | 0 | 0 | 0 | 0 | 0 | 0 | 1 | 0 | 0 | 0 | 0 | 0 | 0 | 0 |
| | ⋮ | | | | : | | | | | | | | | | | | : | | |
| | ↓ | 0 | 0 | 0 | 0 | 0 | 0 | 1 | 1 | 1 | 1 | 0 | 1 | 0 | 0 | 0 | 0 | 0 | 0 |
| | Bright Green | 0 | 0 | 0 | 0 | 0 | 0 | 1 | 1 | 1 | 1 | 1 | 0 | 0 | 0 | 0 | 0 | 0 | 0 |
| Gray scale of blue | Black | 0 | 0 | 0 | 0 | 0 | 0 | 0 | 0 | 0 | 0 | 0 | 0 | 0 | 0 | 0 | 0 | 0 | 0 |
| | Dark | 0 | 0 | 0 | 0 | 0 | 0 | 0 | 0 | 0 | 0 | 0 | 0 | 0 | 0 | 0 | 0 | 0 | 1 |
| | ↑ | 0 | 0 | 0 | 0 | 0 | 0 | 0 | 0 | 0 | 0 | 0 | 0 | 0 | 0 | 0 | 0 | 1 | 0 |
| | ⋮ | | | | : | | | | | | | | | | | | : | | |
| | ↓ | 0 | 0 | 0 | 0 | 0 | 0 | 0 | 0 | 0 | 0 | 0 | 0 | 1 | 1 | 1 | 1 | 0 | 1 |
| | Bright Blue | 0 | 0 | 0 | 0 | 0 | 0 | 0 | 0 | 0 | 0 | 0 | 0 | 1 | 1 | 1 | 1 | 1 | 0 |
| | | | | | | | 0 | 0 | 0 | 0 | 0 | 0 | 1 | 1 | 1 | 1 | 1 | 1 | |

note...This LCD module can display 262,144 colors because the each of R,G,B signals has 6bits' information which represents 64 step brightness levels.

【Electrical Specification(continuation)】

● Block diagram

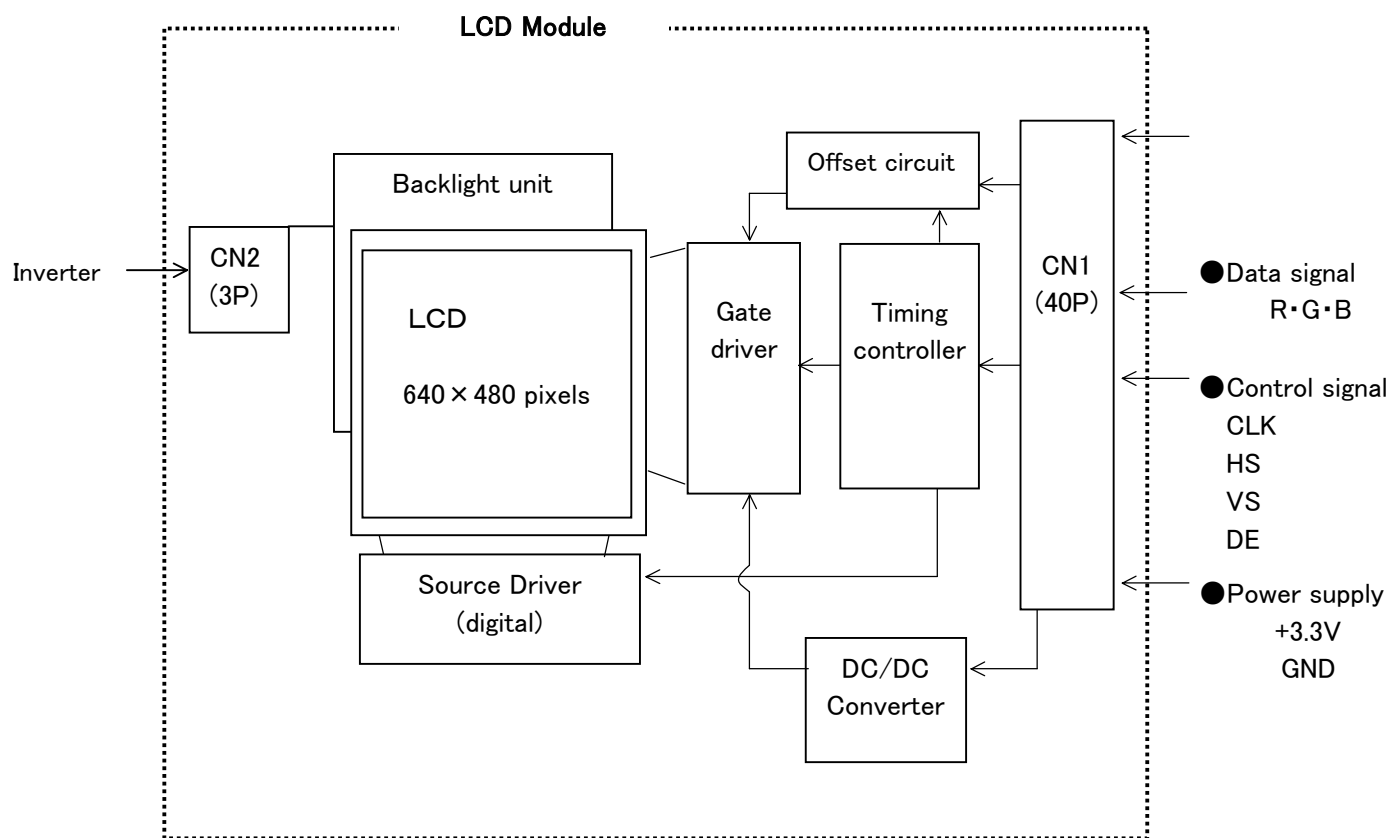

【Backlight】

| CHARACTERISTICS | SYMBOL | MIN | TYP | MAX | UNIT | REMARKS |
|-----------------------------|--------|-------|------|------|-------|-----------|
| Lamp current | IL | 4.0 | 7.0 | 7.5 | mArms | |
| Lamp voltage | VL | — | 480 | — | Vrms | |
| Lamp power consumption | PL | — | 3.36 | — | Wrms | |
| Possible lighting frequency | FL | 40 | — | 60 | kHz | |
| Starting voltage | VS | — | — | 1700 | Vrms | Ta=-10°C |
| Life time | — | 30000 | — | — | Hour | at IL=7mA |
| | | 50000 | — | — | | at IL=6mA |

Attention)

- *1 Panel surface temperature should be kept less than contents of "Absolute Maximum Ratings".
- *2 Inverter should be designed to be subject to the conditions below:
 - (1) Both the area and the peak under the positive and negative cycles of the waveform of the lamp current and lamp voltage should be symmetric.
(The symmetric ratio should be larger than 90%)
 - (2) There should not be any spikes in the waveform.
 - (3) The waveform should be close to a sine wave whenever possible.
 - (4) Lamp current should not exceed the "MAX" value under the "Operating Temperature"(It is prohibited to exceed the "MAX" value even if it is operated in the non-guaranteed temperature). When lamp current exceed the maximum value for a longtime, it may cause a smoking and ignition. Therefore, it is recommended that the inverter have the current limited circuit that is used as a protection circuit and/or the lamp current-controlled inverter.
 - (5) Please check the lamp current not to exceed the "MAX" value in the inverter open/short test.
 - (6) The "MIN" of "Lamp current " is the necessary value which must not be applied to the product for an stable working condition.
Please pay attention to keep the "MIN" of "Lamp current" for a light dimmer.
- *3 The lamp frequency should be selected as different as possible from display horizontal synchronous signal (Including harmonic frequency of this scanning frequency) to avoid "Beat "interference which may be observed on the screen as horizontal stripes like moving wave.
This phenomenon is caused by interference between lamp (CCFL) lighting frequency and LCD horizontal synchronous signal.
- *4 "Life time" is defined as a lamp maker's warranty value which applied to CCFL only.
"Life time" is defined as the lamp brightness decrease to 50% original brightness at IL=MAX; continuous lighting, Ta=25°C.
- *5 Values of "Lamp Voltage", "Lamp power consumption" and "Starting voltage" are defined on condition of the LCD module derived by Toshiba Matsushita Display Technology Co.,Ltd. standard inverter (Harison HIU-742A; 16.5pF).
The "MAX" of "Starting voltage "means the minimum voltage to light normally in the LCD module.
However this isn't the values that we can assure stability of starting lamp on condition that the module is installed in your set.
It is careful that "Starting voltage" is changed by an increase of stray capacitance in your set, inverter method, value of ballast capacitor in your inverter and so on.
Especially, the value of "Starting voltage" is higher in low temperature condition than in normal temperature condition, because impedance of CCFL is increased.
So, please check your set in low temperature condition.

*6 Please do not bring the high voltage wire into contact with metallic frame and the GND lead wire, so as to ensure the safety and decrease the difference of brightness.

*7 Inverter output voltage should be stopped automatically and simultaneously when open-circuit or short-circuit happened between the inverter output and CCFL. (Please design the inverter which has shutdown function in case of no load for inverter output.) Continuous voltage output from the inverter under the open or short circuit may cause excessive leak current and overheat.

However inverter output voltage is required to remain for on-condition at least 3 seconds, because CCFL needs 1 or 2 seconds as start-up time.

*8 "Starting Voltage" and "Lamp voltage" are defined as follows.

(1) Starting voltage

*Use inverter : HIU-742A; 16.5pF

(2) Lamp voltage

*Use inverter : HIU-742A; 16.5pF

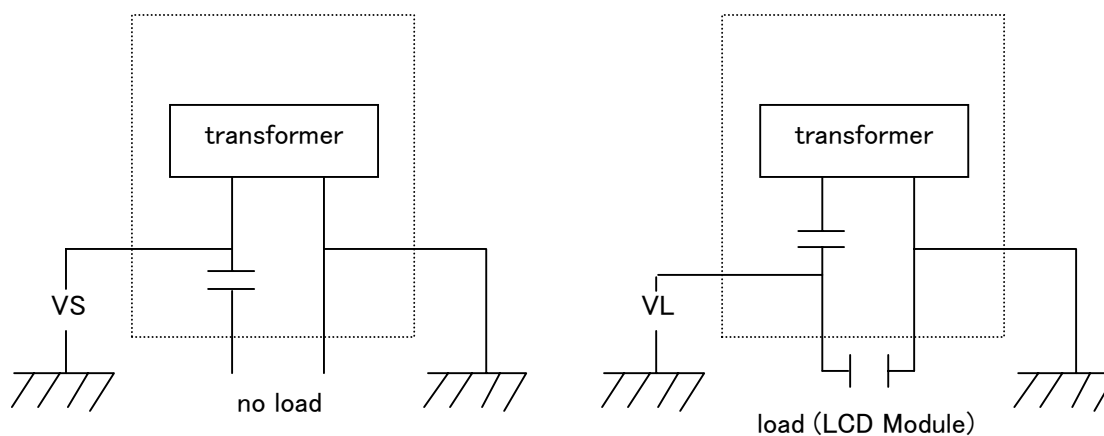

Lamp connector (CN2)

Use Connector : BHR-03VS-1 (JST)

| Pin No. | SYMBOL | FUNCTION | REMARKS |
|---------|--------|----------------------------------|---------------------|
| 1 | H | CCFL Power supply (High Voltage) | cable color : Red |
| 2 | NC | - | - |
| 3 | L | CCFL power supply (Ground) | cable color : Black |

Caution and Handling Precaution

For your end user's safety, it is strongly advised that the items with "※" should be included in the instruction manual of the system which may be issued by your organization.

For Safety



Warning

1) SPECIAL PURPOSES

- a) Toshiba Matsushita Display Technology's Standard LCD modules have not been customized for operation in extreme environments or for use in applications where performance failures could be life-threatening or otherwise catastrophic.
- b) Since they have not been designed for operation in extreme environments, they must never be used in devices that will be exposed to temperatures above 50 degrees Celsius or below 0 degrees Celsius, to X-ray or Gamma-ray radiation, or to abnormally high levels of vibration or shock which exceed Toshiba Matsushita Display Technology's specification limits.
- c) In addition, since Toshiba Matsushita Display Technology's Standard LCD modules have not been designed for use in applications where performance failures could be life-threatening or catastrophic, they must never be installed in aircraft navigation control systems (such as, but not limited to Traffic Collision Avoidance System and Air Traffic Indicator), in military defense or weapons systems, in critical industrial process-control systems (e.g., those involved in the production of nuclear energy), or in critical medical device or patient life-support systems.

2) ELECTRIC SHOCK

DISCONNECT POWER SUPPLY before handling LCD modules. In order to prevent electric shock, DO NOT TOUCH the electrode part, cables, connectors, and the fluorescent lamp's (hereinafter called "FL") circuit part of a module in which FL tubes are built in as a light source of a backlight or a front light. High voltage is supplied to these parts while power supply is turned on.

3) FL CABLE CONNECTION

Make sure to insert the module FL connector to the inverter connector in correct position and correct polarity. If incorrect, this may cause smoke or burn of electrical parts by high voltage of FL circuit. If there is a possibility that the connector has been inserted incorrectly, re-insert the connector only after you confirm the module and FL power is completely off. When disconnecting the connector, do not pull on the cable.

DO NOT USE the mating FL connector which Toshiba Matsushita Display Technology does not specify. Otherwise, Toshiba Matsushita Display Technology shall not be liable for any damages caused by the connector.



Caution

1)※ DISASSEMBLING OR MODIFICATION

DO NOT DISASSEMBLE OR MODIFY the modules.

Sensitive parts inside LCD module may be damaged, and dusts or scratches may mar the displays. Toshiba Matsushita Display Technology does not warrant the modules, if customer disassembled or modified them.

2)※ BREAKAGE OF LCD PANEL

DO NOT INGEST liquid crystal material, DO NOT INHALE this material, and DO NOT PERMIT this material to contact the skin, if glass of LCD panel is broken.

If liquid crystal material contacts the skin, mouth or clothing, take the following actions immediately

In case contact to the eye or mouth, rinse with large amount of running water for more than 15 minutes. In case contact to the skin or clothing, wipe it off immediately and wash with soap and large amount of running water for more than 15 minutes. The skin or clothing may be damaged if liquid crystal material is left adhered.

In case ingestion, rinse out the mouth well with water. After spewing up by drinking large amount of water, get medical treatment.

3)※ GLASS OF LCD PANEL

BE CAREFUL WITH CHIPS OF GRASS that may cause injuring fingers or skin, when the glass is broken. Since FL is also made of glass, when FL is built in, handle it with due caution as well.

4) ABSOLUTE MAXIMUM RATINGS

DO NOT EXCEED the absolute maximum rating values under the worst probable conditions caused by the supply voltage variation, input voltage variation, variation in parts' constants, environmental temperature, etc., otherwise LCD module may be damaged.

5) POWER PROTECTION CIRCUIT

Employ protection circuit for power supply, whenever the specification specifies it. A suitable protection circuit should be applied, based on each system design.

6) DISPOSAL

Always comply all applicable environmental regulations, when disposing of LCD module.

7) EDGES OF PARTS

Be careful with handling the metal frame (bezel) of a module. Even though burr disposal treatment is performed, it may cause injuring. Be careful with edges of glass parts and touch panel identically. For designing the system, give special consideration that the wiring and parts do not touch those edges.

8)※ LUMINANCE DECREASE OF FL

When FL becomes extremely dark and its color changes from white to pink, stop the use of the module immediately. FL, at the end of its life with its discharge color turns into pink as the characteristics of FL, may adversely affect the module at the end part of FL due to temperature raising caused by depletion of the mercury which is contained in FL tube, or may have a possibility of breakage.

For Designing the System

2-1 DESIGNING ENCLOSURE

1) MECHANICAL DIMENSIONS

Refer to the individual specification for LCD module's mechanical dimensions.

2) MOUNTING HOLES

LCD module should be assembled to the system by using all mounting holes specified in the individual specification with the specified screws.

In addition, some modules may not be necessary to use all the mounting holes. Make comprehensive judgments on the entire system.

3)※ BENDING / TWISTING

Make sure to design the enclosure that bending/twisting forces are not applied to LCD module during and after the installation into the system.

4) GASES FROM SETTING MATERIAL

Some plastic materials and shock absorbing materials (rubber) used in the system may generate gases that may cause the deterioration of the polarizer laminated on LCD's panel or internal parts of the module. Prior confirmation is required.

5) GASES FROM PACKAGING MATERIAL

Some materials used for packaging (for which sulfuric acid is used in the recycling process) generate gases that may cause the deterioration of the polarizer laminated on LCD's panel or internal parts of the module. Prior confirmation is required.

2-2 DESIGNING POWER SUPPLIES AND INPUT SIGNALS TO LCD MODULE

1) CAPACITY OF POWER SUPPLY

Refer to individual specification for details for capacity of power supply, and apply some protection circuit including fuses for power supply lines.

2) SEQUENCE OF POWER SUPPLIES AND INPUT SIGNALS

Power supply lines should be designed as follows.

Power supplies should always be turned on before the input signals are applied to LCD module, and the input signals should be disconnected before power supplies are turned off.

The detailed sequence of power supplies and signals are described in the individual specification.

In addition, refer to individual specifications for unused terminals.

3) FL CABLE CONNECTION

Make sure to connect correctly high-voltage wire and low-voltage wire between FL tube and inverter unit.

If high-voltage wire and low-voltage wire are connected incorrectly, it may cause insufficient brightness or unstable operation of FL, and smoke or burn of the parts.

4) PREVENTION OF IMAGE STICKING

Design the system not to display same pattern for a long time in order to prevent image sticking on the panel. Note that incorrect sequence of power supplies and input signals may cause the sticking on the panel, too.

5) GROUNDING OF METAL FRAME

Grounding of metal frame of LCD module is generally effective to prevent radiation interference from the system design.

However, the necessity of grounding, or effective grounding method should be dependent on each system design.

2-3 DESIGNING FOR BETTER VISIBILITY

1) PANEL ANGLE

Visibility of LCD module deeply depends on the viewing directions. The position and the angle of LCD module in the system should be designed so that the best visibility can be obtained at the actual usage.

2) WINDOW OPENING

Dimensions of window opening of the system's enclosure should be designed as smaller than "Viewing Area" and larger than "Active Area" specified in individual specification in order to obtain better appearance.

3) PROTECTIVE COVER

In case of severe environmental condition like outdoor usage, a proper transparent protective cover(lens) over LCD module is recommended to apply in order to prevent scratches, and invasion of dust, water, etc., from the system's window onto LCD module.

Ultra-violet ray cut filter is recommended to apply onto LCD module for outdoor operation. Strong ultra-violet ray may cause damage the panel. However, in that case, transmittance-luminance will decrease. Careful selection of material is required.

2-4 DESIGNING FL POWER SUPPLY CIRCUIT

Input FL starting voltage(VSFL) should be longer than two seconds. If it were not, it may cause unstable operation of FL.

Inverter should be design to stop output when the inverter is no-load to FL tubes (due to breakage of FL, etc.) to prevent high-voltage generation.

When high voltage is applied to FL continuously without normal operation of FL (due to output leakage within FL wiring circuit, etc.) it may cause smoke or burn. To prevent excess current, design the inverter with a protection circuit such as a current limiter (excess current detection) to stop inverter output.

For Installation in Assembly

3-1 ESD (ELECTRO-STATIC DISCHARGE) PREVENTION

The C-MOS LSIs used in LCD module is very sensitive to ESD. The following caution should be taken when installing LCD module to an enclosure of the system in order to prevent damage of C-MOS LSIs used in LCD module.

1) HUMIDITY

Ambient humidity of working area is recommended to be higher than 50%RH in order to avoid ESD.

2) GROUNDING

2-1) Grounded electro-conductive mats are recommended to be covered on the floor of working area and surface of working benches.

2-2) The grounding should be done through a resistor of 0.5-1M ohms in order to prevent spark of ESD.

2-3) Person handling LCD modules should be grounded with wrist band.

2-4) Tools like soldering iron and screw drivers and working benches should be grounded.

3) IONIZER

Using ionizer (an antistatic blower) is recommended at working area in order to reduce electro-static voltage.

4) REMOVING PROTECTION FILM

When removing protection film from LCD panel, peel off the film slowly (more than three seconds) from the edge of the panel with round-ended tweezers or adhesive tape while blowing with ionizer toward the peeling face to minimize ESD which may damage electrical circuit.

5) **Be careful with touching metal portion of testing instruments in order to prevent unnecessary ESD.**

6) **Do not touch the electrode area of PCB and electrical parts like LSI, capacitor, connector pin, etc.**

3-2 DUST AND STAIN PREVENTION

1) WORKING AREA

Reduce dust level in working area. Especially the level of metal particle should be decreased, otherwise electrical circuit in LCD module may be damaged due to short circuit by metal particles.

2) PROTECTION FILM

LCD module may be shipped with "protection film" on LCD panel in order to prevent from scratches and dust.

It is recommended to remove the film at later process of assembling.

3) FINGER PRINT

Use finger stalls or soft and dust-free gloves in order to keep clean appearance of LCD module when handled for incoming inspection and assembly.

4)※ WIPING OFF DUST ON THE PANEL

When LCD panel becomes dirty, wipe the panel surface off softly with absorbent cotton or another soft cloth.

If necessary, breathe upon the panel surface and then wipe off immediately and softly again.

If the dirt can not be wiped off, follow the instructions described in individual specification.

Be careful not to spill organic solvents into the inside of LCD module. The solvents may damage driver IC and PCB area used inside module.

The polarizer laminated to LCD panel and adhesives may be damaged by the solvents, so do not use any organic solvents for wiping off LCD panel.

5) ADHESIVE ON LCD PANEL

Be careful not to attach adhesive, grease, etc., on LCD panel, because it is difficult to remove them without any damages on LCD panel.

6)※ WATER SPOTS ON THE PANEL

Avoid the dewing or water condensation.

Wipe off a spot or spots of water or mist on LCD panel softly with absorbent cotton or another cloth as soon as possible if happened, otherwise discoloration or stain may be caused.

3-3 BENDING / TWISTING OF LCD MODULE DURING ASSEMBLY

1) INSTALLING LCD MODULE TO THE ENCLOSURE

Do not bend or twist LCD module even momentary when LCD module is installed into an enclosure of the system.

2) FASTENING SCREWS

Fasten screws for mounting holes uniformly, otherwise bending / twisting force may be applied to LCD module.

3) INTERFACE / FL CABLES

Do not fasten screws, with catching interface cables or FL cables between LCD module and the enclosure. This may cause bending of LCD module, or become the cause of a failure by damaging cables.

3-4 MECHANICAL FORCES

1)※ STRONG MECHANICAL SHOCK

Refrain from strong mechanical shock like dropping from the working bench or knocking against hard object. These may cause panel crack, damage of FL or other mis-operation.

2)※ EXCESSIVE FORCE

Refrain from excessive force like pushing the surface of LCD panel. This may cause scratches or breakage of the panel, or a failure of the module.

3)※ SCRATCHES ON THE PANEL

Do not put heavy object such as tools, books, etc., and do not pile up LCD modules.

Be careful not to touch surface of the polarizer laminated to the panel with any hard and sharp object. The polarizer is so soft that it can be easily scratched, even the protect film covers it.

4) CONNECTORS

When inserting or disconnecting the connectors to LCD module, be sure not to apply force against PCB nor connecting cables, otherwise internal connection of PCB and TAB drivers may be damaged.

5) FL CABLES

Be careful not to pull the FL cables in order to avoid mechanical damage in FL lamp and soldering area. While mounting, do not bind or twist the FL cables, or the Lamp current may not be applied as designed.

3-5 OPERATION

Be sure that the following caution should be taken under assembly and inspection of the system.

1) POWER SUPPLY

Power supplies should always be turned off in connecting process.

Do not connect or disconnect the power cables and connectors with power applied to LCD module.

2) INPUT SIGNAL

The signal should be applied after power supplies are turned on.

The signal should be removed before power supplies are turned off.

The detailed sequence of power supplies and signals are described in individual specifications.

For Transportation and Storage

1) TEMPERATURE

Do not store LCD modules in high temperature, especially in high humidity for a long time (approximately more than one month).

It is strongly recommended to store LCD modules where the temperature is in the range of 0 to 35 degrees Celsius and the humidity is lower than 70%.

2) LOW TEMPERATURE

Liquid crystal material may be coagulated and LCD panel may be damaged at the lower temperature than storage temperature range described in individual specification.

3) ULTRA VIOLET RAY

Store LCD module without exposure to direct sunlight or fluorescent lamps in order to prevent the module from strong ultra violet ray.

4) CLEANLINESS

Keep the module in clean place, because any dust, hard particle may damage the polarizer, or dust invades the inside of the module.

5)※ CONDENSATION OF WATER

Avoid condensation of water on LCD module, otherwise it may cause mis-operation or defects. Keep away LCD module from such ambient.

6) PACKAGING

In case of transportation or storage after opening the original packaging, LCD modules are recommended to be repacked into the original packaging with the same method, especially with same kind of desiccant.

