



ELECTRONICS

Approval

TO : Quanta
DATE : Mar. 31. 1999

SAMSUNG TFT-LCD
MODEL NO. : LT150X3-124

NOTE :

The information described in this SPEC is preliminary and can be changed without prior notice.

PREPARED BY : Application Engineering Group

SAM SUNG ELECTRONICS CO., LTD.

Doc.No.	LT150X3-124	Rev.No	04-001-G-990331	Page	1 / 26
----------------	-------------	---------------	-----------------	-------------	--------

CONTENTS

Revision History	----- (3)
General Description	----- (4)
1. Absolute Maximum Ratings	----- (5)
1.1 Absolute Ratings of environment	
1.2 Electrical Absolute Ratings	
2. Optical Characteristics	----- (7)
3. Electrical Characteristics	----- (10)
3.1 TFT LCD Module	
3.2 Backlight Unit	
4. Block Diagram	----- (13)
4.1 TFT LCD Module	
4.2 Backlight Unit	
5. Input Terminal Pin Assignment	----- (14)
5.1 Input Signal & Power	
5.2 LVDS Interface	
5.3 Backlight Unit	
5.4 Timing Diagrams of LVDS For Transmitting	
5.5 Input Signals, Basic Display Colors and Gray Scale of Each Color.	
5.6 Pixel format	
6. Interface Timing	----- (19)
6.1 Timing Parameters	
6.2 Timing Diagrams of interface Signal	
6.3 Power ON/OFF Sequence	
7. Outline Dimension	----- (21)
8. General Precautions	----- (22)
9. Packing	----- (24)
10. Marking & Others	----- (25)

REVISION HISTORY

Approval

Date	Rev.No.	Page	Summary
Mar. 03.1999	000	13	General SPEC of LT150X3 -124 was first issued. Startup Voltage changed (0°C) 1250 --> 1300Vrms Note(5) changed
	001	5 7 10 15 24 25	Approval SPEC of LT150X3 -124 Weight : 685(max) --> 690(max) Brightness : 110(min), 130(typ) ---> 120(min), 150(typ) Current of power supply : Max current changed 540mA -> 545mA Error correction(Flat Link Interface) Add Packing Add Marking & Others

Doc.No.

LT150X3-124

Rev.No

04-001-G-990331

Page

3 / 26

GENERAL DESCRIPTION

DESCRIPTION

LT150X3-124 is a color active matrix TFT (Thin Film Transistor) liquid crystal display (LCD) that uses amorphous silicon TFT as a switching devices. This model is composed of a TFT LCD panel, a driver circuit and a backlight system. The resolution of a 15.0" contains 1,024 x 768 pixels and can display up to 262,144 colors. 6 O'clock direction is the Optimum viewing angle.

FEATURES

- Thin and lght weight
- High contrast ratio
- XGA ((1024x768) pixels) resolution
- Low power consumption
- DE (Data enable) only mode.
- 3.3V LVDS (FPD Link) Interface with 1 pixel / clock

APPLICATIONS

- Notebook PC and desktop monitors
- Display terminals for AV application products
- Monitors for Industrial machine
- If the usage of this product is not for PC application, but for others, please contact SEC

GENERAL INFORMATION

ITEM	SPECIFICATION	UNIT	NOTE
Display area	304.128(H)X228.096(V) (15.0"diagonal)	mm	
Driver element	a-si TFT active matrix		
Display colors	262,144		
Number of pixel	1024 x 768	pixel	
Pixel arrangement	RGB vertical stripe		
Pixel pitch	0.297(H) x 0.297(V) (TYP.)	mm	
Display Mode	Normally white		
Surface treatment	Haze 12, Hard-Coating 3H		

Mechanical Information

ITEM		MIN.	TYP.	MAX.	NOTE
Module size	Horizontal (H)	315.5	315.8	316.1	mm
	Vertical (V)	240.2	240.5	240.8	mm
	Depth (D)	6.9	7.2	7.5	mm
Weight		-	-	690	g

1. ABSOLUTE MAXIMUM RATINGS

1.1 ENVIRONMENTAL ABSOLUTE RATINGS

ITEM	SYMBOL	MIN.	MAX.	UNIT	NOTE
Storage temperate	T_{STG}	-25	60	°C	(1)
Operating temperate (Temperature of glass surface)	T_{OPR}	0	50	°C	(1)
Shock (nonoperating)	S_{nop}	-	220	G	(2),(4)
Vibration (nonoperating)	V_{nop}	-	1.5	G	(3),(4)

Note (1) Temperature and relative humidity range are shown in the figure below.

95 % RH Max. ($40\text{ °C} \geq T_a$)

Maximum wet - bulb temperature at 39 °C or less. ($T_a > 40\text{ °C}$) No condensation

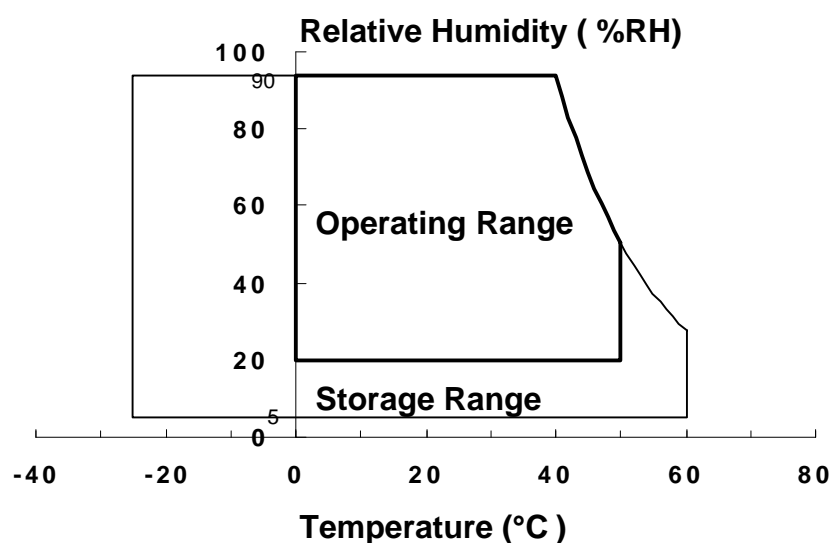

(2) 2ms, half sine wave, one time for $\pm X$, $\pm Y$, $\pm Z$.

(3) 10 - 300 Hz, Sweep rate 10 min, 30 min for X, Y, Z.

(4) At testing Vibration and Shock, the fixture in holding the Module to be tested have to be hard and rigid enough so that the Module would not be twisted or bent by the fixture.

1.2 ELECTRICAL ABSOLUTE RATINGS

(1) TFT LCD MODULE

VDD =3.3V, Vss=GND= 0V

ITEM	SYMBOL	MIN.	MAX.	UNIT	NOTE
Power Supply Voltage	VDD	Vss -0.3	VDD +0.3	V	
Logic Input Voltage	VIN	Vss -0.3	VDD +0.3	V	

Note 1) Within Ta = (25 ± 2 °C)

(2) BACK-LIGHT UNIT

Ta = 25 ± 2 °C

ITEM	SYMBOL	MIN.	MAX.	UNIT	NOTE
Lamp Current	IL	3.0	7.0	mArms	(1)
Lamp frequency	FL	35	80	kHz	(1)

Note 1) Permanent damage to the device may occur if maximum values are exceeded
 Functional operation should be restricted to the conditions described under normal operating condition

2. OPTICAL CHARACTERISTICS

The following items are measured under stable conditions. The optical characteristics should be measured in a dark room or equivalent state with the methods shown in Note (5).
Measuring equipment : TOPCON BM-5A

* Ta = 25 ± 2 °C, V_{DD}=3.3V, fv= 60Hz, fdCLK=65MHz, (IL = 5 mA)

ITEM	SYMBOL	CONDITION	MIN.	TYP.	MAX.	UNIT	NOTE	
Contrast Ratio (5 Points)	CR	$\phi = 0,$ $\theta = 0$ Normal Viewing Angle	150	-	-		(1), (2), (5)	
Response Time at Ta	Rising		T _R	-	10	20	msec	(1), (3)
	Falling		T _F	-	30	50		
Average Luminance of White (5 Points)	Y _{L,AVE}			120	150	-	cd/m ²	(1), (4)
Color Chromaticity (CIE)	Red		R _X	0.550	0.580	0.610		(1), (5)
			R _Y	0.320	0.350	0.380		
	Green		G _X	0.280	0.310	0.340		
			G _Y	0.500	0.530	0.560		
	Blue		B _X	0.120	0.150	0.180		
			B _Y	0.120	0.150	0.180		
	White	W _X	0.280	0.310	0.340			
		W _Y	0.310	0.340	0.370			
Viewing Angle	Hor.	θ_L	45	-	-	Degrees		
		θ_R	45	-	-			
	Ver.	ϕ_H	10	-	-			
		ϕ_L	30	-	-			
13 Points White Variation	δ_L		-	-	1.75		(6)	

Note 1) Definition of Viewing Angle : Viewing angle range(10 ° C/R)

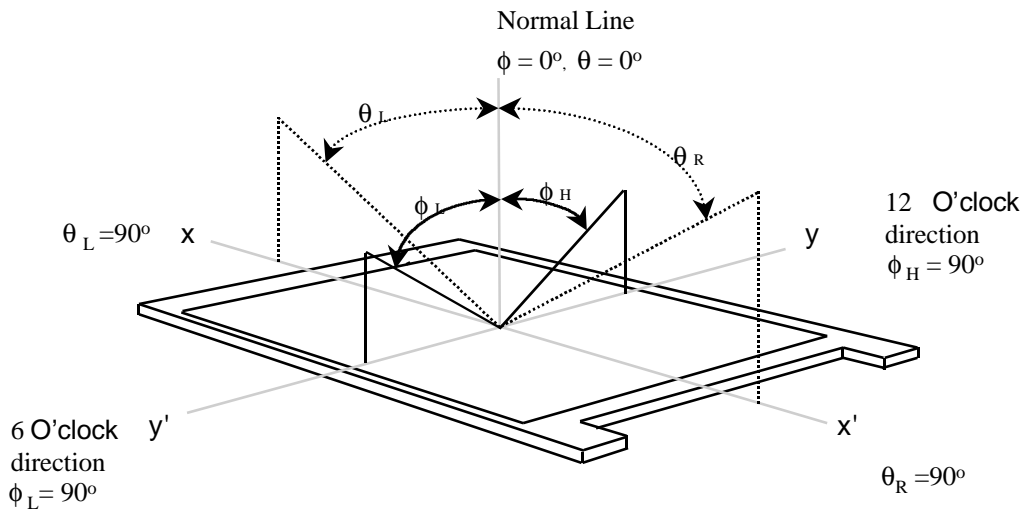

Note 2) Definition of Contrast Ratio (CR) : Ratio of gray max (Gmax) ,gray min (Gmin) at 5 points(4, 5, 7, 9, 10)

$$CR = \frac{CR(4) + CR(5) + CR(7) + CR(9) + CR(10)}{5}$$

POINTS : (4), (5), (7), (9), (10) at FIGURE OF NOTE 6)

Note 3) Definition of Response time :

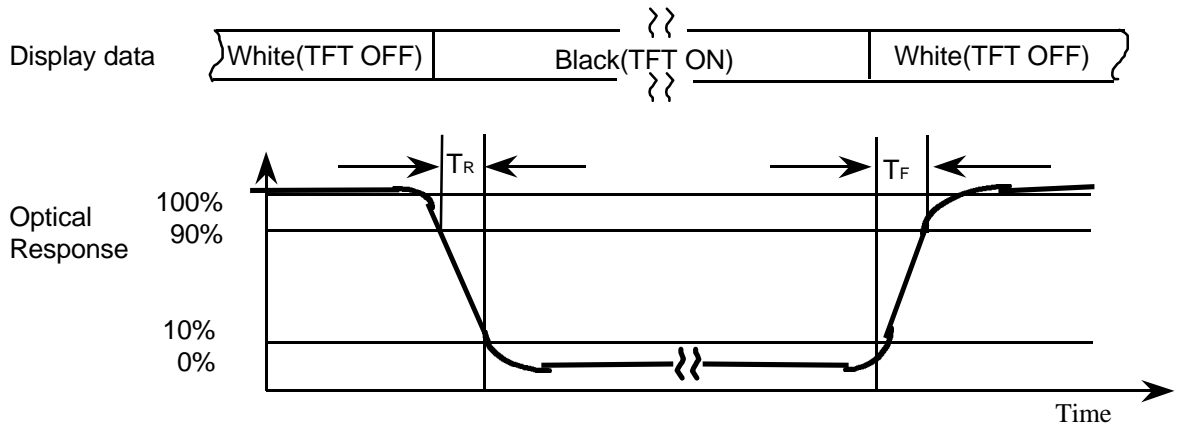

Note 4) Definition of Average Luminance of White : measure the luminance of white at 5 points.

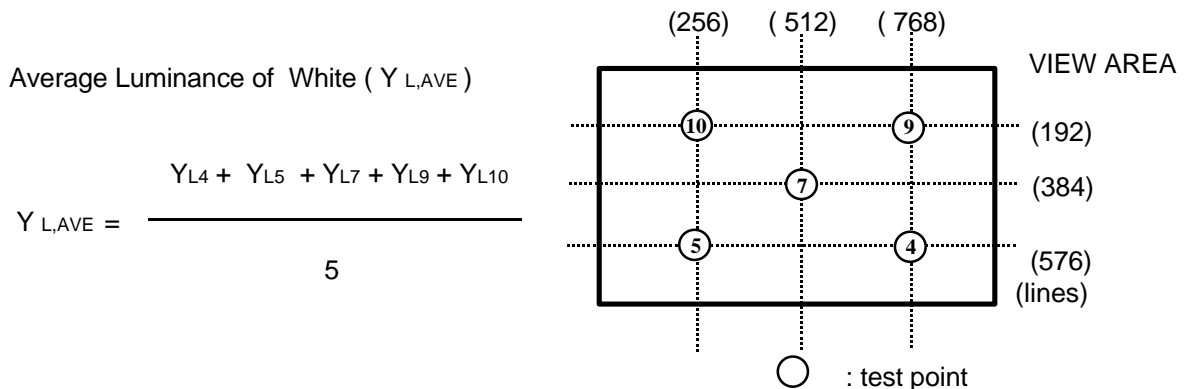

Average Luminance of White ($Y_{L,AVE}$)

$$Y_{L,AVE} = \frac{Y_{L4} + Y_{L5} + Y_{L7} + Y_{L9} + Y_{L10}}{5}$$

Note 5) After stabilizing and leaving the panel alone at a given temperature for 30 min , the measurement should be executed. Measurement should be executed in a stable, windless, and dark room. 30 min after lighting the backlight. This should be measured in the center of screen.
 Lamp current : 5.0mA
 Environment condition : $T_a = 25 \pm 2 \text{ }^\circ\text{C}$

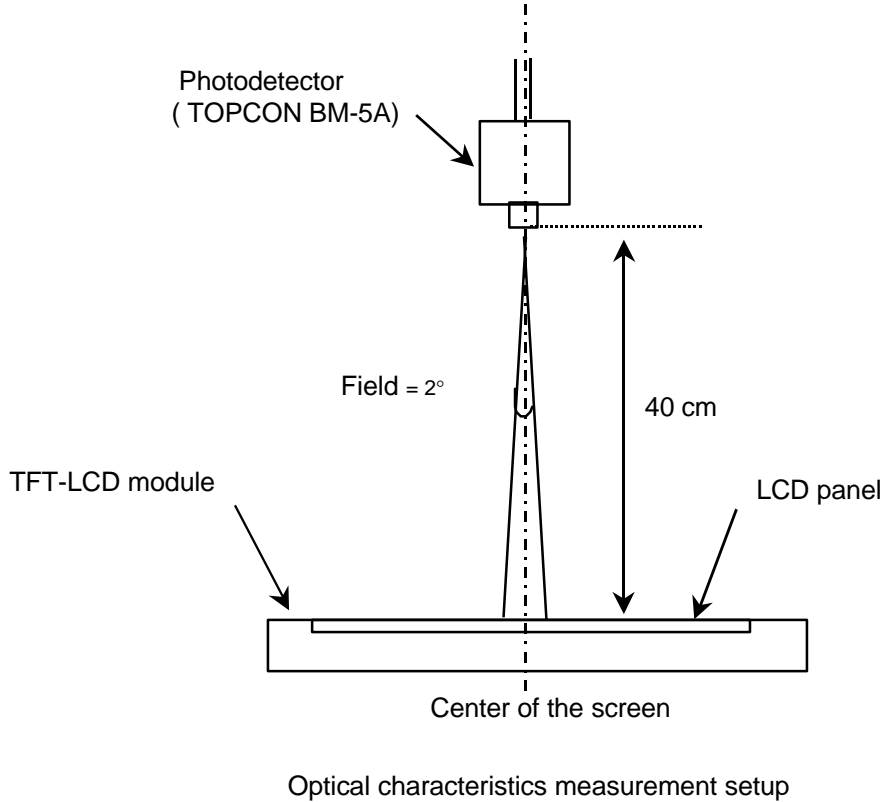

Note 6) Definition of 13 points white variation (δ_L), CR variation (C_{VER}) [① ~ ⑬]

$$\delta_L = \frac{\text{Maximum luminance of 13 points}}{\text{Minimum luminance of 13 points}}$$

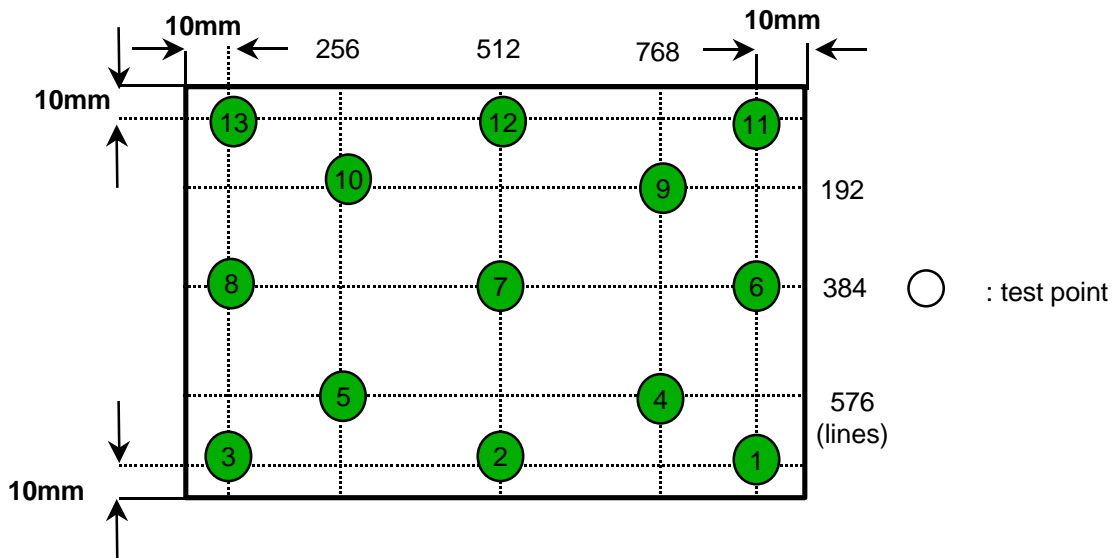

3. ELECTRICAL CHARACTERISTICS

Approval

3.1 TFT LCD MODULE

Ta= 25 ± 2 °C

ITEM		SYMBOL	MIN	TYP	MAX	UNIT	NOTE
Voltage of Power Supply		V _{DD}	3.0	3.3	3.6	V	
Differential Input Voltage for LVDS Receiver Threshold	High	V _{IH}	-	-	+100	mV	V _{CM} =+1.2V
	Low	V _{IL}	-100	-	-	mV	
Vsync Frequency		f _V	-	60	-	Hz	
Hsync Frequency		f _H	-	48.2	-	KHz	
Main Frequency		f _{DCLK}	-	65	-	MHz	
Rush Current		I _{RUSH}	-	-	1.5	A	(4)
Current of Power Supply	White	I _{DD}	-	250	-	mA	(2),(3)*a
	Mosaic		-	303	-	mA	(2),(3)*b
	V.stripe		-	520	545	mA	(2),(3)*c

- Note (1) Display data pins and timing signal pins should be connected.(GND=0V)
 (2) f_V=60Hz, f_{DCLK} =65MHZ, V_{DD} = 3.3V , DC Current.
 (3) Power dissipation pattern

*a) White Pattern

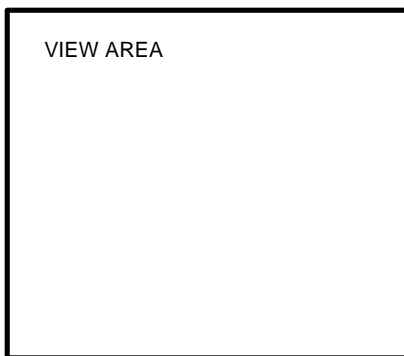

*b) Mosaic Pattern

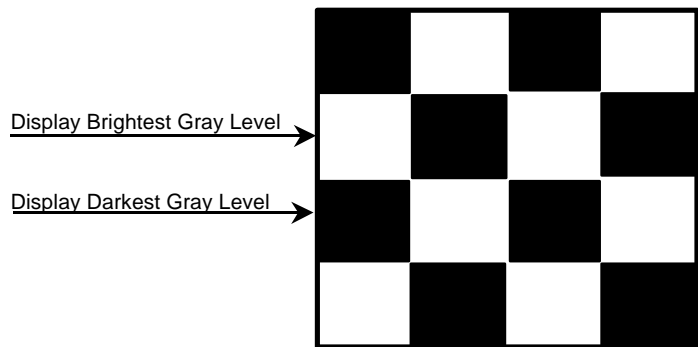

*c) Vertical stripe pattern(Vertical line at the width of 2 pixels)

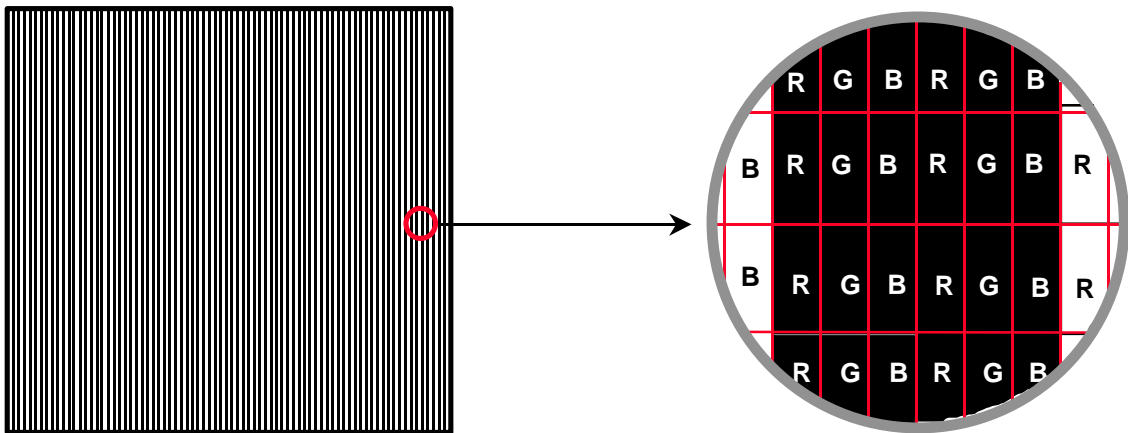

4) Rush current measurement condition

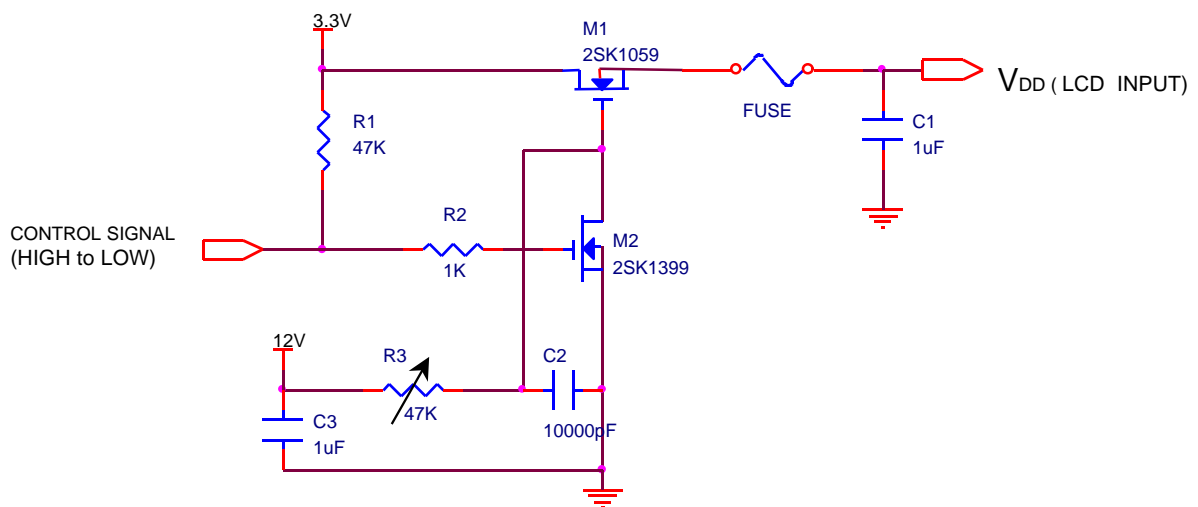

V_{DD} rising time is 470us

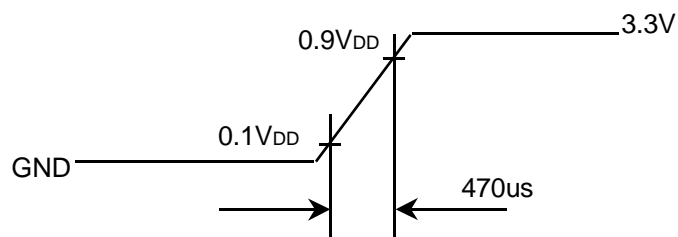

3.2 BACK-LIGHT UNIT

The backlight system is an edge - lighting type with a single CCFT (Cold Cathode Fluorescent Tube).
The characteristics of a single lamp are shown in the following tables.

INVERTER : SIC-130T

LAMP : KLN6308G2952980

Ta= 25 ± 2 °C

ITEM	SYMBOL	MIN	TYP	MAX	UNIT	NOTE
Lamp Current	I _L	3.0	5.0	6.0	mArms	(1)
Lamp Voltage	V _L	-	670	-	V _{rms}	I _L =5.0mA
Frequency	f _L	40	-	60	KHz	(2)
Power Consumption	P _L	-	3.35	-	W	(3) I _L =5.0mA
Operating Life Time	Hr	10,000	-	-	Hour	(4)
Startup Voltage	V _s	-	-	1100 (25 °C)	V _{rms}	(5)
				1300 (0 °C)		

Note) The waveform of the inverter output voltage must be area symmetric and the design of the inverter must have specifications for the modularized lamp.

The performance of the backlight, for example life time or brightness, is much influenced by the characteristics of the DC-AC inverter for the lamp. So all the parameters of an inverter should be carefully designed so as not to produce too much leakage current from high-voltage output of the inverter.

When you design or order the inverter, please make sure that a poor lighting caused by the mismatch of the backlight and the inverter(miss lighting, flicker, etc.) never occur. When you confirm it, the module should be operated in the same condition as it is installed in your instrument.

Note (1) Lamp current is measured with a high frequency current meter as shown below.

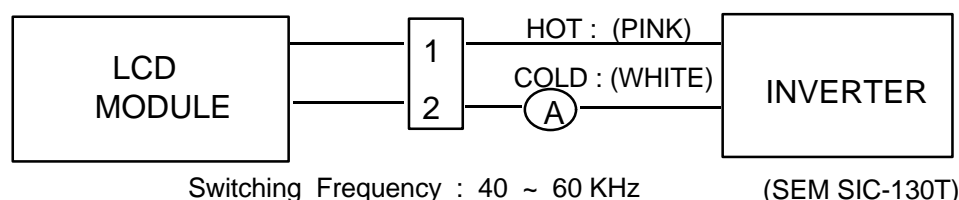

(2) Lamp frequency may produce interference with horizontal synchronous frequency and this may cause line flow on the display. Therefore lamp frequency should be detached from the horizontal synchronous frequency and its harmonics as far as possible in order to avoid interference.

(3) refer to I_L × V_L to calculate.

(4) Life time (Hr) of a lamp can be defined as the time in which it continues to operate under the condition Ta= 25 ± 2 °C and I_L = 5.0 mArms until one of the following event occurs.

1. When the brightness becomes 50% or lower than the original.

2. When the Effective ignition length becomes 80% or lower than the original value.

(Effective ignition length is defined as an area that has less than 70% brightness compared to the brightness in the center point.)

(5) The inverter open voltage - this voltage should be measured after ballast capacitor- have to be larger than the lamp startup voltage, otherwise backlight may has blinking for a moment after turns on or not be turned on.

If an inverter has shutdown function it should keep its open voltage for longer than 1 second even if lamp connector open.

4. BLOCK DIAGRAM

4.1 TFT LCD Module

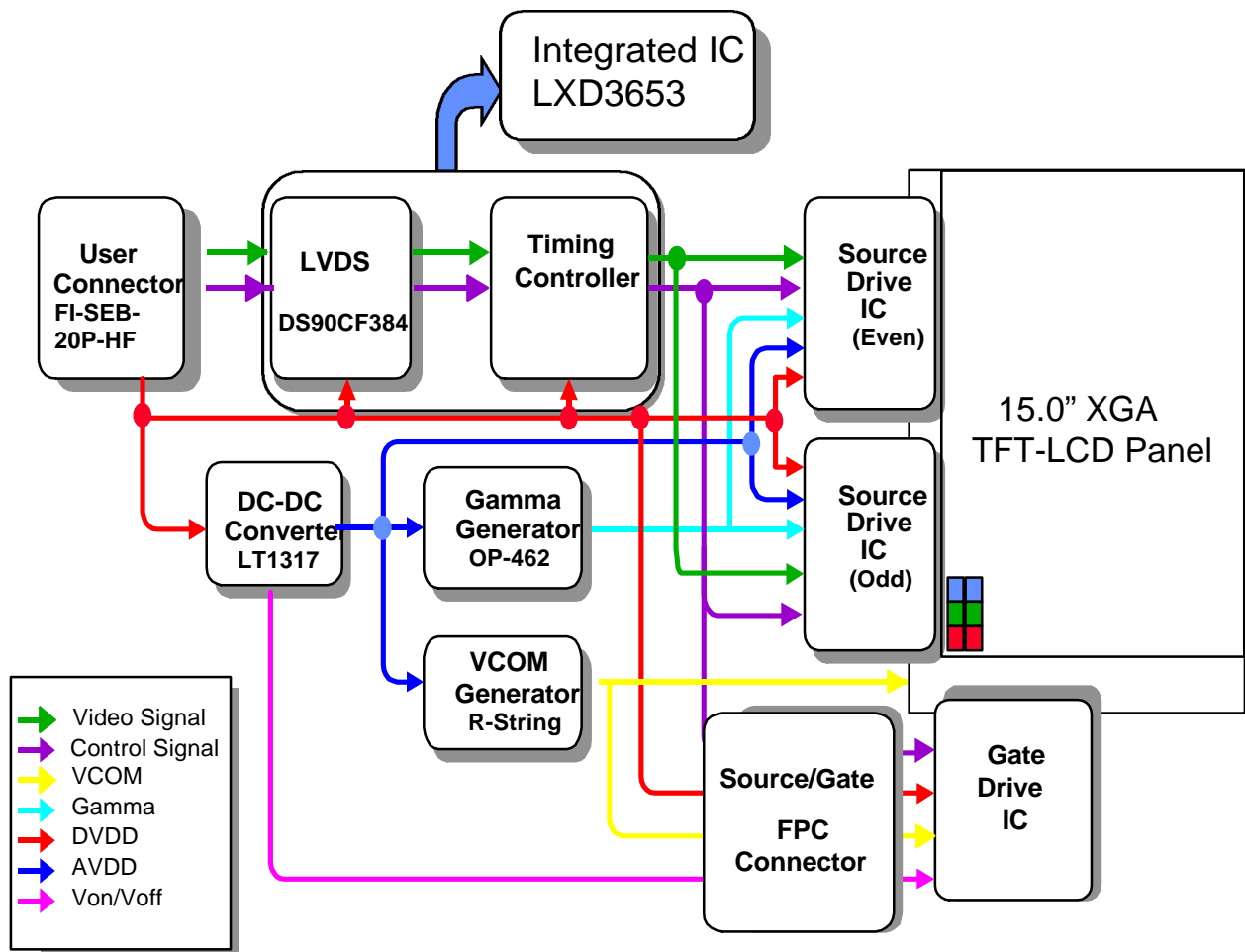

4.2 BACK-LIGHT UNIT

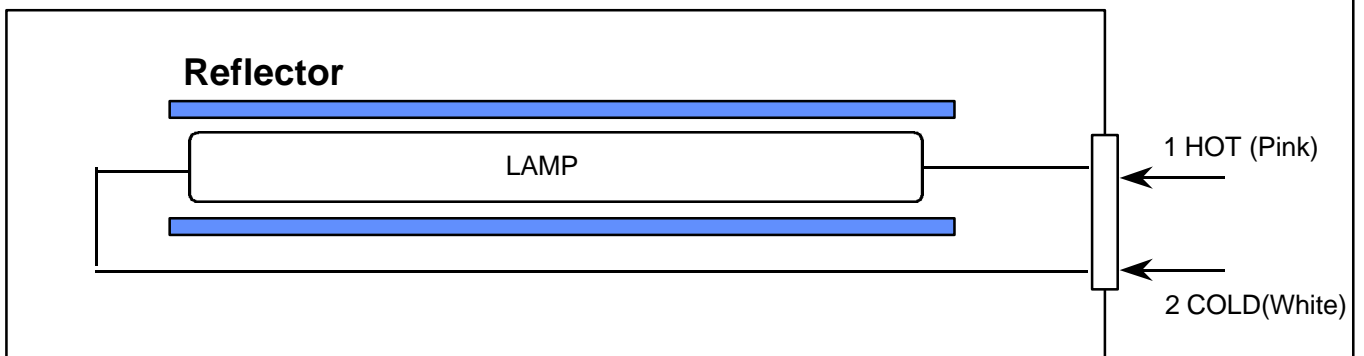

Note) The output of the inverter may change according to the material of the reflector.

5. INPUT TERMINAL PIN ASSIGNMENT

5.1. Input Signal & Power (LVDS, Connector : JAE FI-SEB20P-HF10-E1500
Mating Connector : JAE FI-SE20M-HF)

PIN NO	SYMBOL	FUNCTION	POLARITY	REMARK
1	VDD	POWER SUPPLY +3.3V		
2	VDD	POWER SUPPLY +3.3V		
3	GND	GROUND		
4	GND	GROUND		
5	RxIN0-	LVDS Differential Data INPUT	Negative	R0~R5 G0
6	RxIN0+	LVDS Differential Data INPUT	Positive	
7	GND	GROUND		
8	RxIN1-	LVDS Differential Data INPUT	Negative	G1~G5 B0~B1
9	RxIN1+	LVDS Differential Data INPUT	Positive	
10	GND	GROUND		
11	RxIN2-	LVDS Differential Data INPUT	Negative	B2~B5,DE Hsync,Vsync
12	RxIN2+	LVDS Differential Data INPUT	Positive	
13	GND	GROUND		
14	RxCLKIN-	LVDS Differential Data INPUT	Negative	
15	RxCLKIN+	LVDS Differential Data INPUT	Positive	
16	GND	GROUND		
17	NC	No Connection		
18	NC	No Connection		
19	GND	GROUND		
20	GND	GROUND		

5.2 LVDS Interface : Transmitter DS90CF383 (National Semiconductor) or Compatible

Pin No.	Name	RGB Signal	Pin No.	Name	RGB Signal
51	TxIN0	R0	14	TxIN14	G5
52	TxIN1	R1	15	TxIN15	B0
54	TxIN2	R2	19	TxIN18	B1
55	TxIN3	R3	20	TxIN19	B2
56	TxIN4	R4	22	TxIN20	B3
3	TxIN6	R5	23	TxIN21	B4
4	TxIN7	G0	24	TxIN22	B5
6	TxIN8	G1	27	TxIN24	Hsync
7	TxIN9	G2	28	TxIN25	Vsync
11	TxIN12	G3	30	TxIN26	DE
12	TxIN13	G4	31	TxCLKIN	Clock

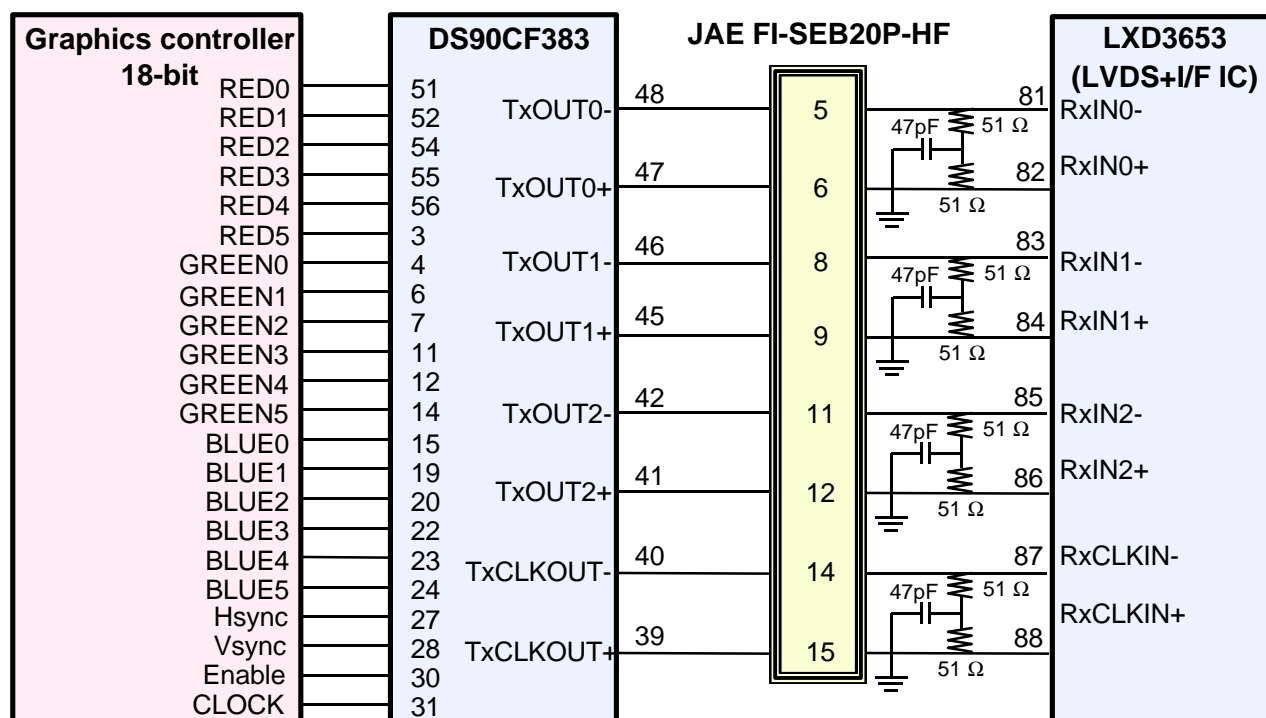
FLAT LINK INTERFACE

Note : The LCD Module uses 2 51ohm resistors and 47pF between positive and negative lines of each receiver input.

5.3 BACK LIGHT UNIT

Connector : JST BHSR - 02VS -1
Mating Connector : SM02B-BHSS-1(JST)

Pin NO.	Symbol	Color	Function
1	HOT	Pink	High Voltage
2	COLD	White	Low Voltage

5.4 Timing Diagrams of LVDS For Transmission

LVDS Receiver : LXD3653(including I/F IC)

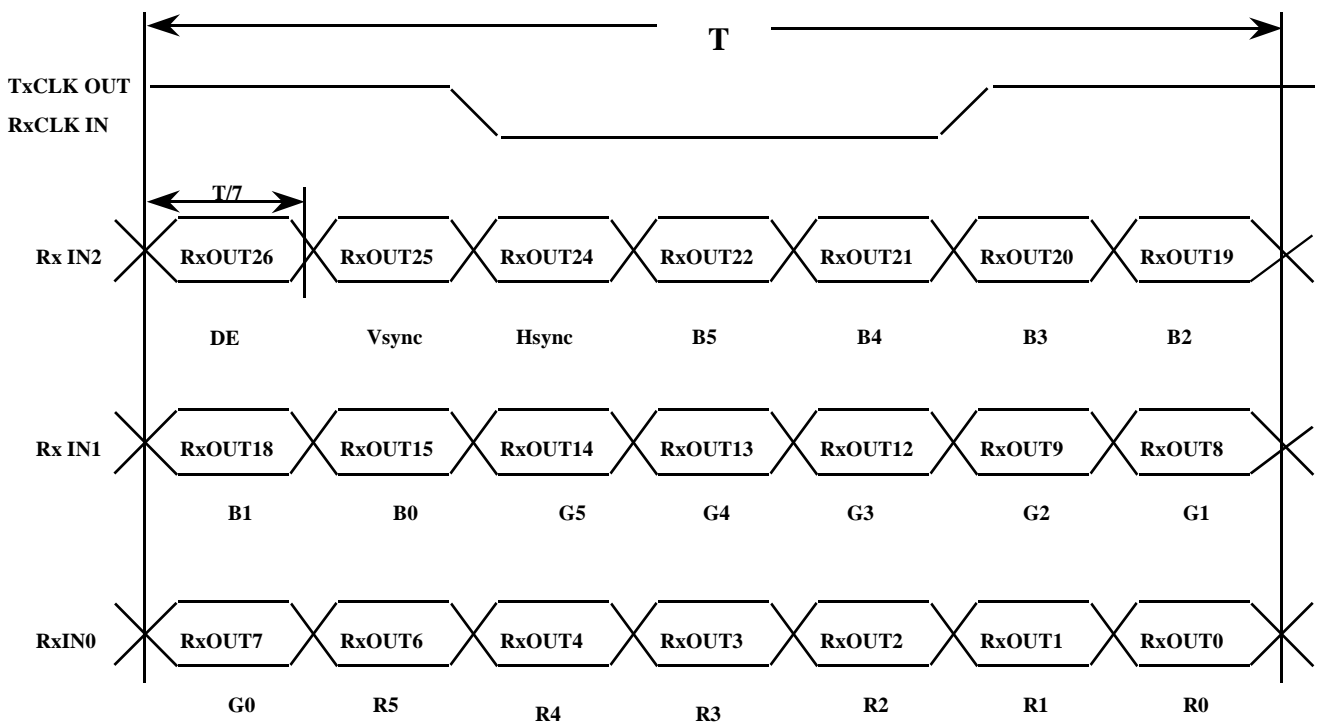

5.5 Input Signals, Basic Display Colors and Gray Scale of Each Color

COLOR	DISPLAY	DATA SIGNAL																	GRAY SCALE LEVEL
		RED					GREEN					BLUE							
		R0	R1	R2	R3	R4	R5	G0	G1	G2	G3	G4	G5	B0	B1	B2	B3	B4	
BASIC COLOR	BLACK	0	0	0	0	0	0	0	0	0	0	0	0	0	0	0	0	0	-
	BLUE	0	0	0	0	0	0	0	0	0	0	0	0	1	1	1	1	1	-
	GREEN	0	0	0	0	0	0	1	1	1	1	1	1	0	0	0	0	0	-
	CYAN	0	0	0	0	0	0	1	1	1	1	1	1	1	1	1	1	1	-
	RED	1	1	1	1	1	1	0	0	0	0	0	0	0	0	0	0	0	-
	MAGENTA	1	1	1	1	1	1	0	0	0	0	0	0	1	1	1	1	1	-
	YELLOW	1	1	1	1	1	1	1	1	1	1	1	1	0	0	0	0	0	-
WHITE	1	1	1	1	1	1	1	1	1	1	1	1	1	1	1	1	1	-	
GRAY SCALE OF RED	BLACK	0	0	0	0	0	0	0	0	0	0	0	0	0	0	0	0	0	R0
	DARK jè	1	0	0	0	0	0	0	0	0	0	0	0	0	0	0	0	0	R1
		0	1	0	0	0	0	0	0	0	0	0	0	0	0	0	0	0	R2
		:	:	:	:	:	:	:	:	:	:	:	:	:	:	:	:	:	R3-R60
		:	:	:	:	:	:	:	:	:	:	:	:	:	:	:	:	:	
	jé LIGHT	1	0	1	1	1	1	0	0	0	0	0	0	0	0	0	0	0	R61
		0	1	1	1	1	1	0	0	0	0	0	0	0	0	0	0	0	R62
RED	1	1	1	1	1	1	0	0	0	0	0	0	0	0	0	0	0	R63	
GRAY SCALE OF GREEN	BLACK	0	0	0	0	0	0	0	0	0	0	0	0	0	0	0	0	0	G0
	DARK jè	0	0	0	0	0	0	1	0	0	0	0	0	0	0	0	0	0	G1
		0	0	0	0	0	0	0	1	0	0	0	0	0	0	0	0	0	G2
		:	:	:	:	:	:	:	:	:	:	:	:	:	:	:	:	:	G3-G60
		:	:	:	:	:	:	:	:	:	:	:	:	:	:	:	:	:	
	jé LIGHT	0	0	0	0	0	0	1	0	1	1	1	1	0	0	0	0	0	G61
		0	0	0	0	0	0	0	1	1	1	1	1	0	0	0	0	0	G62
GREEN	0	0	0	0	0	0	1	1	1	1	1	1	0	0	0	0	0	G63	
GRAY SCALE OF BLUE	BLACK	0	0	0	0	0	0	0	0	0	0	0	0	0	0	0	0	0	B0
	DARK jè	0	0	0	0	0	0	0	0	0	0	0	0	1	0	0	0	0	B1
		0	0	0	0	0	0	0	0	0	0	0	0	0	1	0	0	0	B2
		:	:	:	:	:	:	:	:	:	:	:	:	:	:	:	:	:	B3-B60
		:	:	:	:	:	:	:	:	:	:	:	:	:	:	:	:	:	
	jé LIGHT	0	0	0	0	0	0	0	0	0	0	0	0	1	0	1	1	1	B61
		0	0	0	0	0	0	0	0	0	0	0	0	0	1	1	1	1	B62
BLUE	0	0	0	0	0	0	0	0	0	0	0	0	1	1	1	1	1	B63	

Note 1) Definition of gray :

Rn: Red gray, Gn: Green gray, Bn: Blue gray (n=gray level)

Note 2) Input signal: 0 =Low level voltage, 1=High level voltage

5.6 Pixel Format in the display

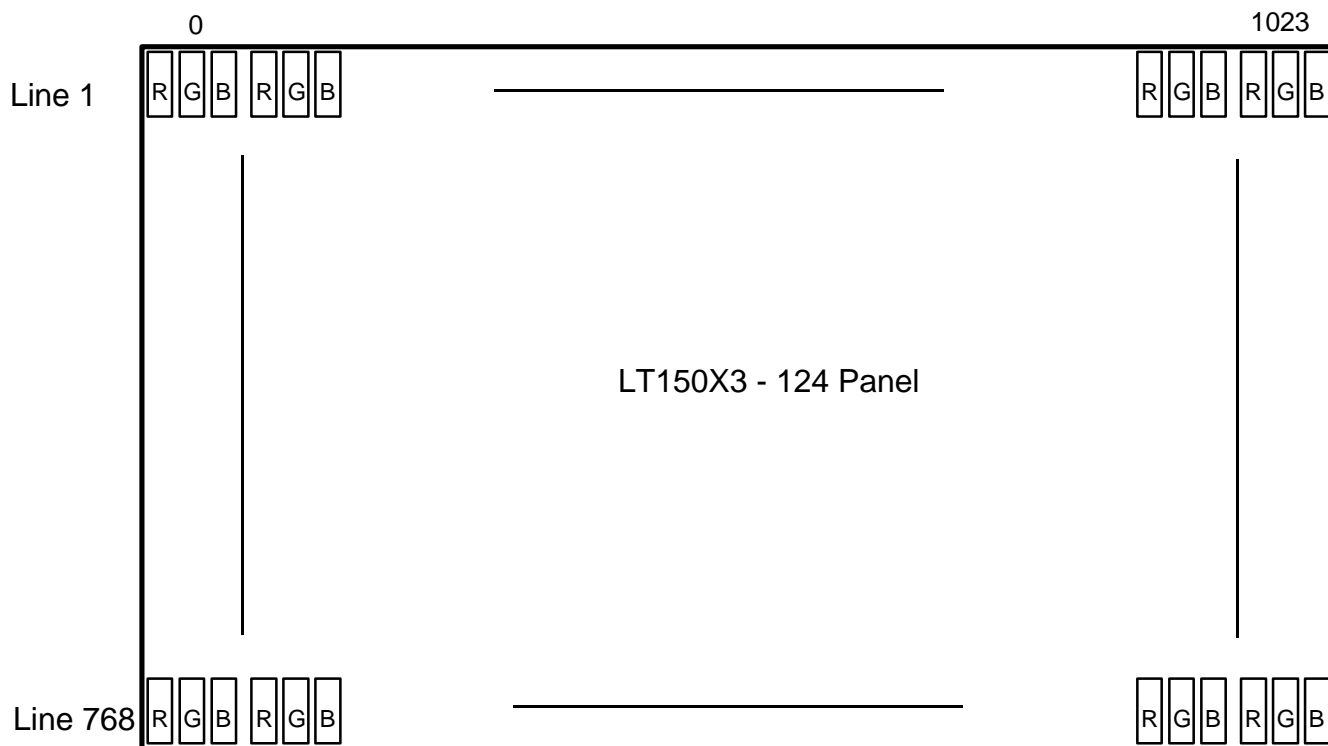

6. INTERFACE TIMING

6.1 Timing Parameters

Signal	Item	Symbol	MIN	TYP	MAX	Unit	Note
Frame Frequency	Cycle	T_V	-	806	-	lines	
Vertical Active Display Term	Display Period	T_{VD}	-	768	-	lines	
One Line Scanning Time	Cycle	T_H	-	1344	-	clocks	
Horizontal Active Display Term	Display Period	T_{HD}	-	1024	-	clocks	

6.2 Timing diagrams of interface signal

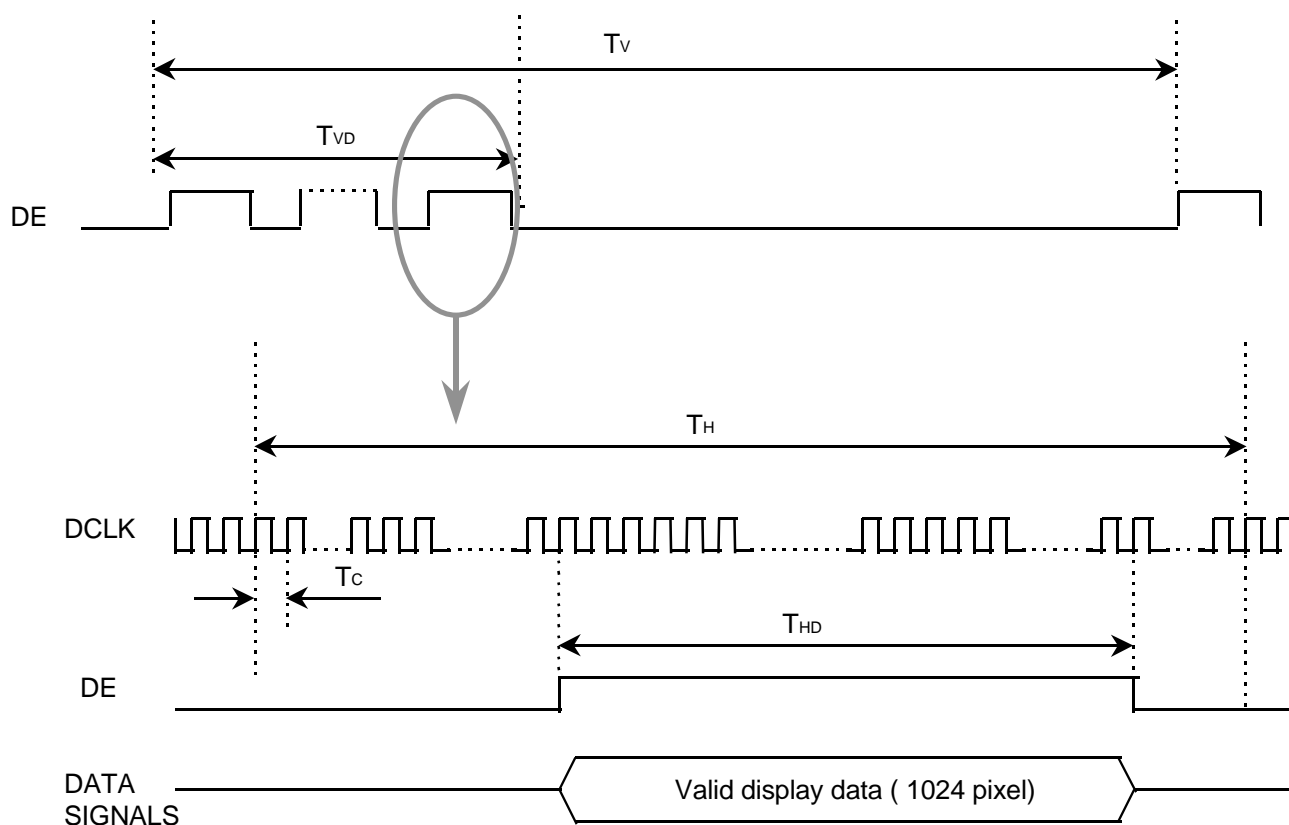

Note : All input condition(level&timing) for FPD85310 are the same with those of NS DS90CF384 or compatible.

6.3 Power ON/OFF Sequence

: To prevent a latch-up or DC operation of the LCD module, the power on/off sequence shall be as shown below.

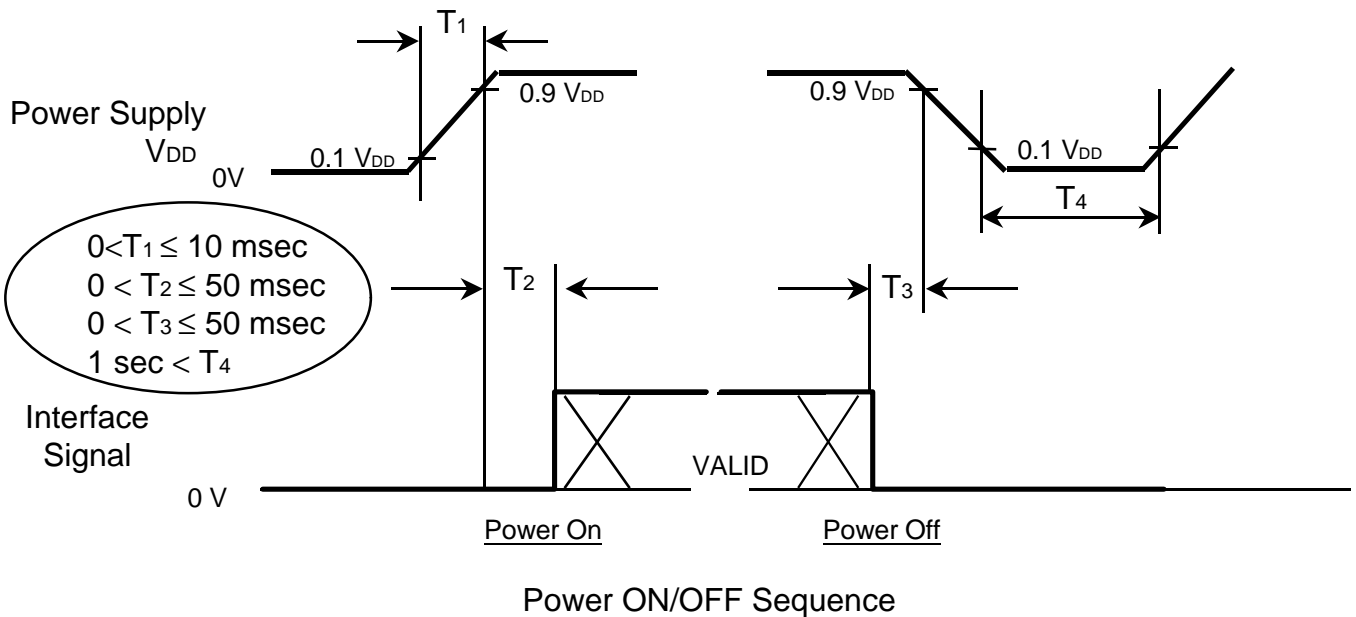

NOTE.

- (1) The supply voltage of the external system for the module input should be the same as the definition of V_{DD} .
- (2) Apply the lamp voltage within the LCD operation range. When the backlight turns on before the LCD operation or the LCD turns off before the backlight turns off, the display may momentarily become white.
- (3) In case of $V_{DD} = \text{off level}$, please keep the level of input signals on the low or keep a high impedance.
- (4) T_4 should be measured after the module has been fully discharged between power off and on period.
- (5) Interface signal shall not be kept at high impedance when the power is on.

8. GENERAL PRECAUTIONS

1. Handling

- (a) When the module is assembled, It should be attached to the system firmly using every mounting holes. Be careful not to twist and bend the modules.
- (b) Refrain from strong mechanical shock and / or any force to the module. In addition to damage, this may cause improper operation or damage to the module and CCFT backlight.
- (c) Note that polarizers are very fragile and could be easily damaged. Do not press or scratch the surface harder than a HB pencil lead.
- (d) Wipe off water droplets or oil immediately. If you leave the droplets for a long time, Staining and discoloration may occur.
- (e) If the surface of the polarizer is dirty, clean it using some absorbent cotton or soft cloth.
- (f) The desirable cleaners are water, IPA(Isoprophyl Alcohol) or Hexane. Do not use Ketone type materials(ex. Acetone), Ethyl alcohol, Toluene, Ethyl acid or Methyl chloride. It might permanent damage to the polarizer due to chemical reaction.
- (g) If the liquid crystal material leaks from the panel, it should be kept away from the eyes or mouth . In case of contact with hands, legs or clothes, it must be washed away thoroughly with soap.
- (h) Protect the module from static , it may cause damage to the C-MOS Gate Array IC.
- (i) Use fingerstalls with soft gloves in order to keep display clean during the incoming inspection and assembly process.
- (j) Do not disassemble the module.
- (k) Do not pull or fold the lamp wire.
- (l) Do not adjust the variable resistor which is located on the back side.
- (m) Pins of I/F connector shall not be touched directly with bare hands.

2. STORAGE

- (a) Do not leave the module in high temperature, and high humidity for a long time.
It is highly recommended to store the module with temperature from 0 to 35 °C and relative humidity of less than 70%.
- (b) Do not store the TFT-LCD module in direct sunlight.
- (c) The module shall be stored in a dark place. It is prohibited to apply sunlight or fluorescent light during the store.

3. OPERATION

- (a) Do not connect, disconnect the module in the “ Power On” condition.
- (b) Power supply should always be turned on/off by following item 6.3 “ Power on/off sequence “.
- (c) Module has high frequency circuits. Sufficient suppression to the electromagnetic interference shall be done by system manufacturers. Grounding and shielding methods may be important to minimize the interference.
- (d) The cable between the backlight connector and its inverter power supply shall be a minimized length and be connected directly . The longer cable between the backlight and the inverter may cause lower luminance of lamp(CCFT) and may require higher startup voltage(Vs).

4. OTHERS

- (a) Ultra-violet ray filter is necessary for outdoor operation.
- (b) Avoid condensation of water. It may result in improper operation or disconnection of electrode.
- (c) Do not exceed the absolute maximum rating value. (the supply voltage variation, input voltage variation, variation in part contents and environmental temperature, so on)
Otherwise the module may be damaged.
- (d) If the module displays the same pattern continuously for a long period of time, it can be the situation when the image “sticks” to the screen.
- (e) This module has its circuitry PCB's on the rear side and should be handled carefully in order not to be stressed.

9. Packing

9.1 CARTON(Internal Packing)

(1) Packing Form

Corrugated fiberboard box and corrugated foam as shock absorber

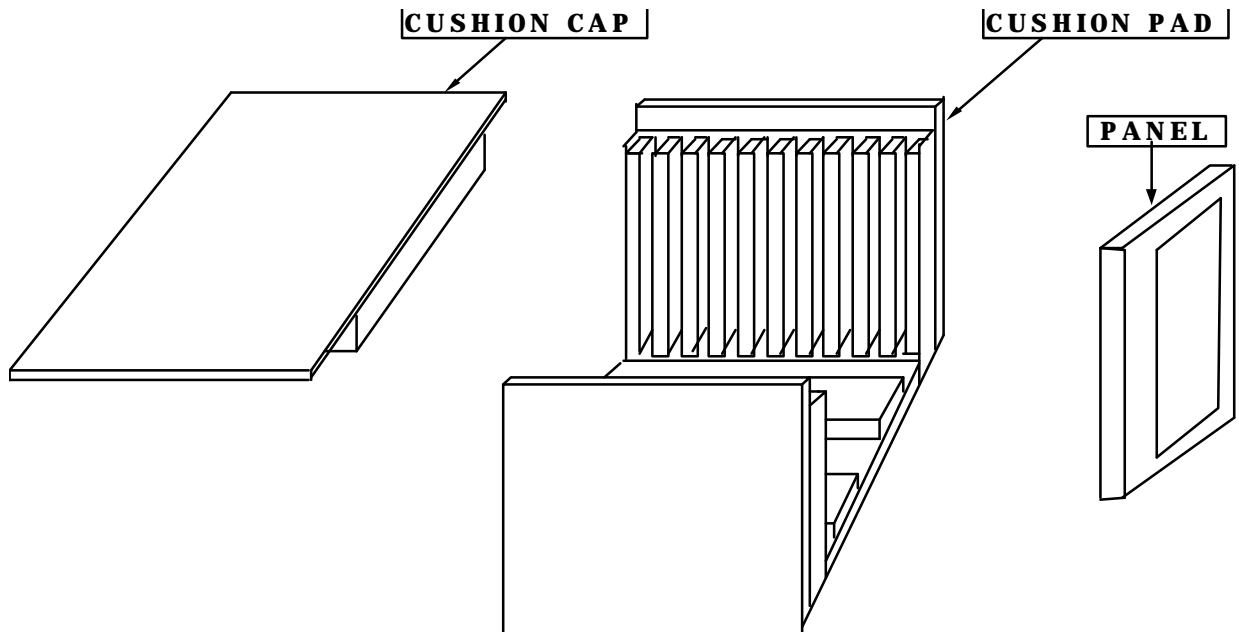

(2) Packing Method

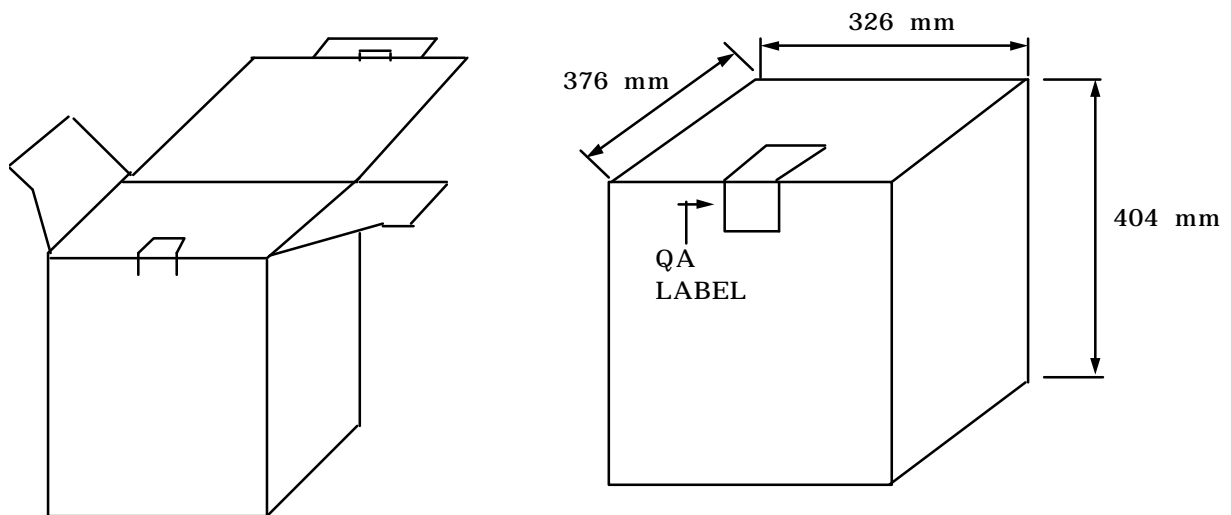

Note (1) Acceptance number of piling : 10 sets

(2) Carton size : 376 (W) X 326 (D) X 404 (H)

(3)Packing Material

NO.	Parts name	Quantity
1.	Static electric protective sack	10 pcs
2.	Packing case (inner box) include shock absorber	1 set
3.	Pictorial marking	2 pics
4.	Desiccant (50g)	1
5.	Carton	1 set

10. Marking & Others

A nameplate bearing followed by is affixed to a shipped product at the specified location on each product.

(1)Parts number : LT150X3-124

(2)Revision : One letter

(3)Control Code : One letter

(4)Lot number : 2 0 A 000 A -00

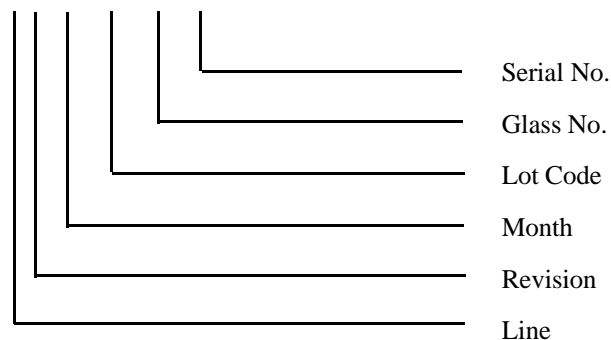

(5) Nameplate Indication

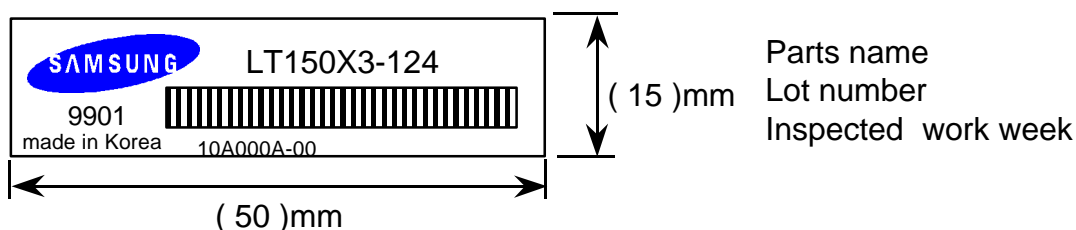

High voltage caution label

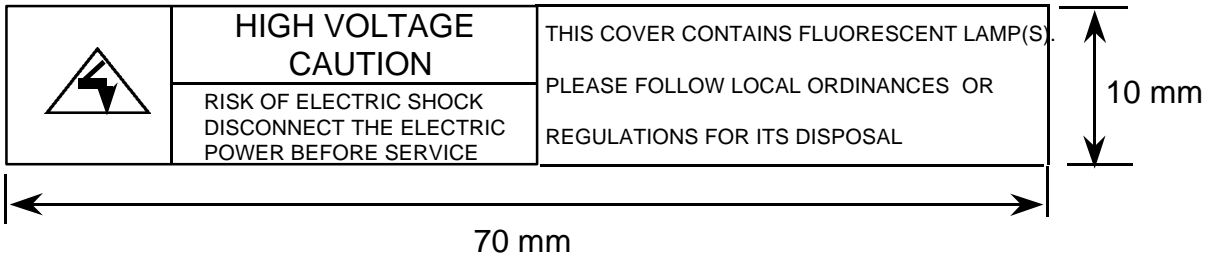

(6) Packing box attach

