



ELECTRONICS

Approval

TO :
DATE : Mar. 05, 1999

SAMSUNG TFT-LCD
MODEL NO. : LT121SU-121

NOTE :

Any Modification of Spec is not allowed without SEC' permission

PREPARED BY : Application Engineering Group

SAMSUNG ELECTRONICS CO., LTD.

Doc.No.	LT121SU-121	Rev.No	04-003-S-990305	Page	1 / 23
----------------	-------------	---------------	-----------------	-------------	--------

CONTENTS

Revision History	----- (3)
General Description	----- (4)
1. Absolute Maximum Ratings	----- (5)
1.1 Environmental Absolute Ratings	
1.2 Electrical Absolute Ratings	
2. Optical Characteristics	----- (7)
3. Electrical Characteristics	----- (10)
3.1 TFT LCD Module	
3.2 Backlight Unit	
4. Block Diagram	----- (13)
4.1 TFT LCD Module	
4.2 Backlight Unit	
5. Input Terminal Pin Assignment	----- (14)
5.1 Input Signal & Power	
5.2 LVDS Transmitter : SN75LVDS8(Ti) or Compatible	
5.3 Input Signals, Basic Display Colors and Gray Scale of Each Color.	
5.4 Backlight Unit	
5.5 Pixel format	
6. Interface Timing	----- (18)
6.1 Timing Parameters	
6.2 Timing Diagrams of interface Signal	
6.3 Power ON/OFF Sequence	
7. Outline Dimension	----- (21)
8. General Precautions	----- (22)

REVISION HISTORY

Approval

Date	Rev.No.	Page	Summary
May.22.1998	000	All	LT121SU-121 model was First issued
Nov.19.1998	001	07	Optical Characteristics Average Luminance of White 100cd(typ) / 5.5mA ---> 120cd(typ) / 5.5mA
		18	Interface Timing Gate Array High, Low Level changed High : 2.0V → 0.8Vdd Low : 0.8 V → 0.2Vdd
Feb.23.1999	002	ALL	Model name was changed : LT121SU-121 ---> LT121SU-122
		5	Test condition of shock & vibration were updated
		7	Color coordinates were confirmed
		10	Current consumption value was confirmed
		19	Timing diagram of interface signals was updated
Mar.05.1999	003	21	Outline dimension drawing is updated
		ALL	Model name was changed: LT121SU-122 ---> LT121SU-121

Doc.No.

LT121SU-121

Rev.No

04-003-S-990305

Page

3 / 23

GENERAL DESCRIPTION

DESCRIPTION

LT121SU-121 is a color active matrix TFT (Thin Film Transistor) liquid crystal display (LCD) that uses amorphous silicon TFT as a switching devices. This model is composed of a TFT LCD panel, a driver circuit and a backlight system. The resolution of a 12.1" contains 800 x 600 pixels and can display up to 262,144 colors. 6 O'clock direction is the Optimum viewing angle.

FEATURES

- Thin and light weight
- High contrast ratio
- SVGA (800x600 pixels) resolution
- Low power consumption
- Sync & DE (Data enable) mode.
- 3.3V Power Supply
- 3.3V LVDS interface with 1pixel/clock

APPLICATIONS

- Notebook PC and desktop monitors
- Display terminals for AV application products
- Monitors for Industrial machine
- If the usage of this product is not for PC application, but for others, please contact SEC

GENERAL INFORMATION

ITEM	SPECIFICATION	UNIT	NOTE
Display area	246.0(H)X184.5(V) (12.1" diagonal)	mm	
Driver element	a-si TFT active matrix		
Display colors	262,144		
Number of pixel	800 x 600	pixel	
Pixel arrangement	RGB vertical stripe	mm	
Pixel pitch	0.3075(H) x 0.3075(V) (TYP.)		
Display Mode	Normally white		
Surface treatment	HAZE 25, HARD-COATING (3H)		

Mechanical Information

ITEM		MIN.	TYP.	MAX.	NOTE
Module size	Horizontal (H)	274.5	275.0	275.5	
	Vertical (V)	198.5	199.0	199.5	
	Depth (D)	-	-	5.5	
Weight		-	-	430g	

1. ABSOLUTE MAXIMUM RATINGS

1.1 ENVIRONMENTAL ABSOLUTE RATINGS

ITEM	SYMBOL	MIN.	MAX.	UNIT	NOTE
Storage temperate	T_{STG}	-25	60	°C	(1)
Operating temperate (Temperature of glass surface)	T_{OPR}	0	50	°C	(1)
Shock (nonoperating)	S_{nop}	-	330cm/s 60G	G	(2),(4)
Vibration (nonoperating)	V_{nop}	-	1.5	G	(3),(4)

Note (1) Temperature and relative humidity range are shown in the figure below.

95 % RH Max. ($40\text{ }^{\circ}\text{C} \geq T_a$)

Maximum wet - bulb temperature at $39\text{ }^{\circ}\text{C}$ or less. ($T_a > 40\text{ }^{\circ}\text{C}$) No condensation

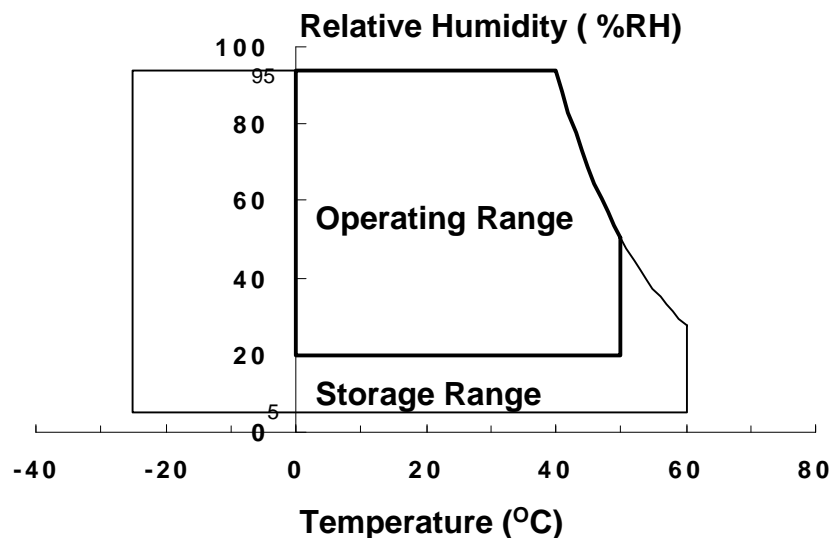

(2) (330cm/s, 2ms) ms, Half sine wave, one time for X , Y , Z .

(60G, 11ms), Square wave, one time for X , Y , Z .

(3) (5) - (150) - (5) Hz, Sweep rate (1.0) min, (120) min for X, Y, Z.

(4) At testing Vibration and Shock, the fixture in holding the Module to be tested have to be hard and rigid enough so that the Module would not be twisted or bent by the fixture.

1.2 ELECTRICAL ABSOLUTE RATINGS

(1) TFT LCD MODULE

VDD =3.3V, Vss=GND= 0V

ITEM	SYMBOL	MIN.	MAX.	UNIT	NOTE
Power Supply Voltage	VDD	VSS -0.3	VDD +0.3	V	
Logic Input Voltage	VIN	VSS -0.3	VDD +0.3	V	

Note 1) Within Ta = 25 ± 2 °C

(2) BACK-LIGHT UNIT

Ta = 25 ± 2 °C

ITEM	SYMBOL	MIN.	MAX.	UNIT	NOTE
Lamp Current	IL	3.0	6.5	mArms	(1)
Lamp frequency	FL	40	80	kHz	(1)

Note 1) Permanent damage to the device may occur if maximum values are exceeded
 Functional operation should be restricted to the conditions described under normal operating condition

2. OPTICAL CHARACTERISTICS

The following items are measured under stable conditions. The optical characteristics should be measured in a dark room or equivalent state with the methods shown in Note (5).

Measuring equipment : TOPCON BM-5A

* Ta = 25°C , VDD=3.3V, fv= 60Hz, fdCLK=40MHz, IL = 5.5mA

ITEM	SYMBOL	CONDITION	MIN.	TYP.	MAX.	UNIT	NOTE	
Contrast Ratio (5 Points)	CR	$\theta = 0$ Normal Viewing Angle	120	-	-		(1), (2), (5)	
Response Time at Ta	Rising		T _R	-	20	30	msec	(1), (3)
	Falling		T _F	-	30	50		
Average Luminance of White (5 Points)	Y _{LAVE}			90	110	-	cd/m ²	(1), (4) at 5.0mA
Color Chromaticity (CIE)	Red		R _x	0.564	0.594	0.624		(1), (5) Measuring Equipment : PR-650
			R _y	0.315	0.345	0.375		
	Green		G _x	0.288	0.318	0.348		
			G _y	0.465	0.495	0.525		
	Blue		B _x	0.126	0.156	0.186		
			B _y	0.117	0.147	0.177		
	White	W _x	0.283	0.313	0.343			
		W _y	0.299	0.329	0.359			
Viewing Angle	Hor.	θ_L	45	-	-	Degrees		
		θ_R	45	-	-			
	Ver.	ϕ_H	15	-	-			
		ϕ_L	30	-	-			
13 Points White Variation	δ_L		-	-	50%		(6)	

Note 1) Definition of Viewing Angle : Viewing angle range($10 < C/R$)

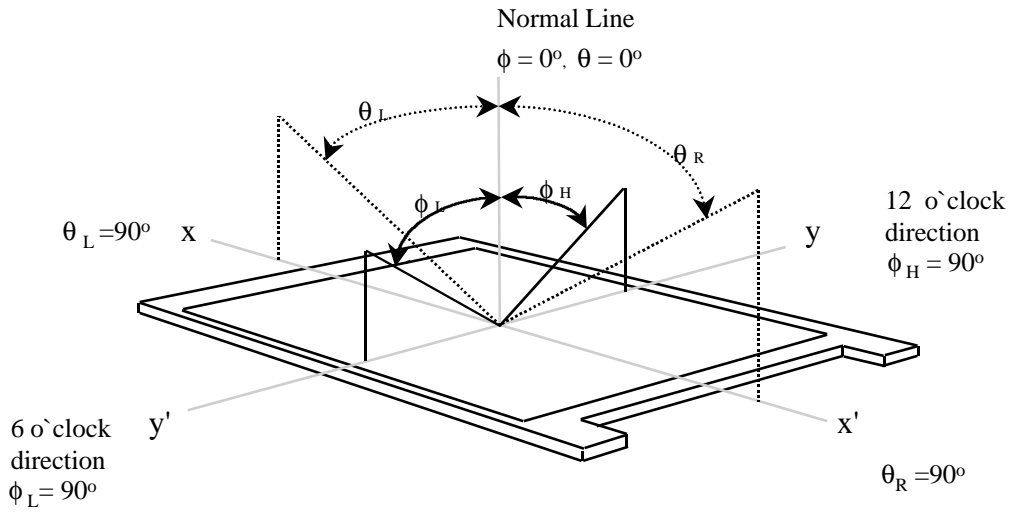

Note 2) Definition of Contrast Ratio (CR) : Ratio of gray max (Gmax) ,gray min (Gmin) at 5 points(4, 5, 7, 9, 10)

$$CR = \frac{CR(4) + CR(5) + CR(7) + CR(9) + CR(10)}{5}$$

POINTS : (4), (5), (7), (9), (10) at FIGURE OF NOTE 6)

Note 3) Definition of Response time :

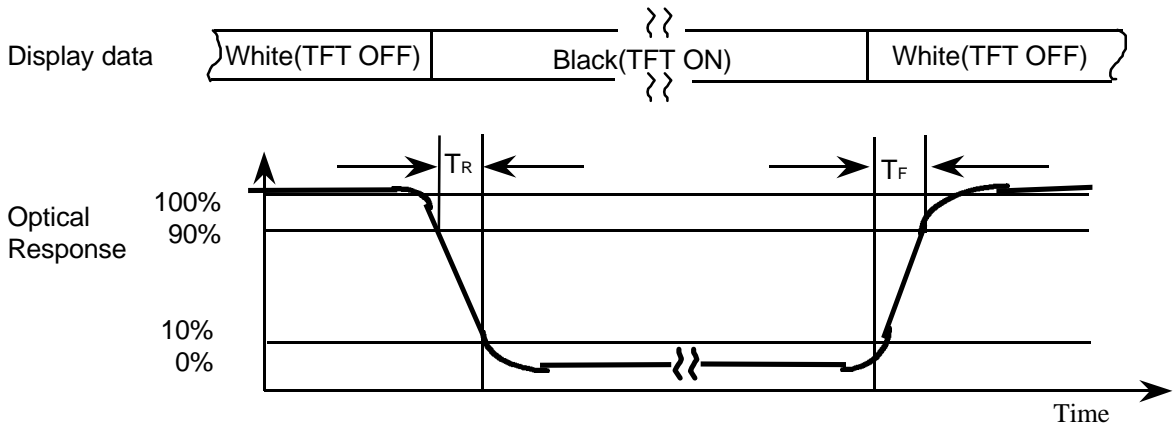

Note 4) Definition of Average Luminance of White : measure the luminance of white at 5 points.

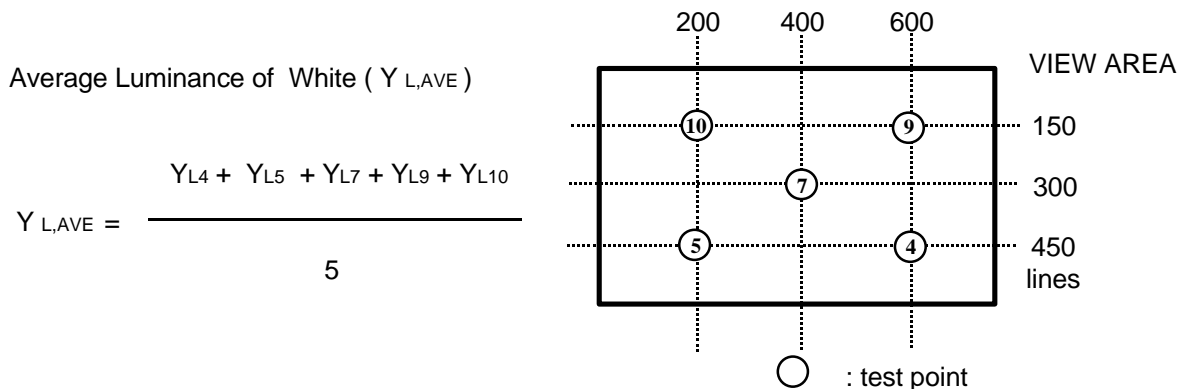

Average Luminance of White ($Y_{L,AVE}$)

$$Y_{L,AVE} = \frac{Y_{L4} + Y_{L5} + Y_{L7} + Y_{L9} + Y_{L10}}{5}$$

Note 5) After stabilizing and leaving the panel alone at a given temperature for 30 min , the measurement should be executed. Measurement should be executed in a stable, windless, and dark room. 30 min after lighting the backlight. This should be measured in the center of screen.
 Lamp current : 5.0mA
 Environment condition : $T_a = 25^{\circ}\text{C} \pm 2^{\circ}\text{C}$

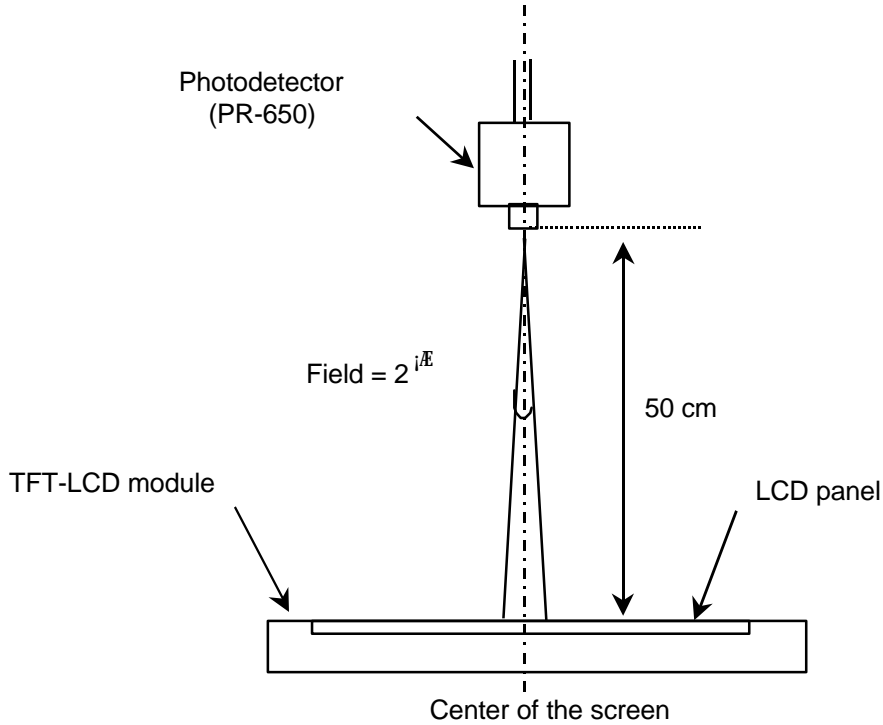

Optical characteristics measurement setup

Note 6) Definition of 13 points white variation (δ_w), CR variation (C_{VER}) [① ~ ⑬]

$$\delta L = \frac{\text{Maximum luminance of 13 points}}{\text{Minimum luminance of 13 points}}$$

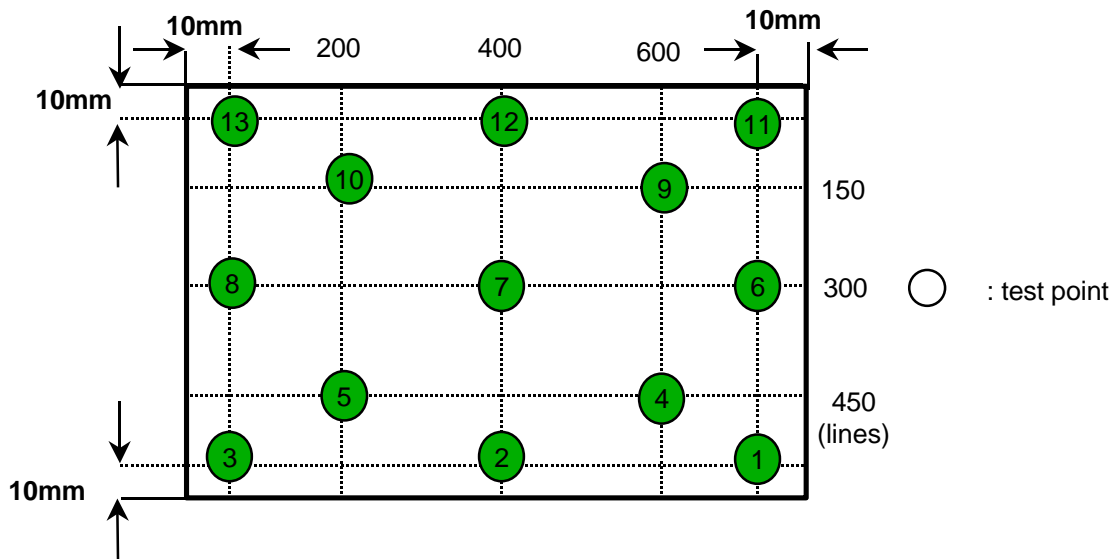

3. ELECTRICAL CHARACTERISTICS

3.1 TFT LCD MODULE

 $T_a = 25 \pm 2 \text{ } ^\circ\text{C}$

ITEM	SYMBOL	MIN	TYP	MAX	UNIT	NOTE	
Voltage of Power Supply	V_{DD}	3.0	3.3	3.6	V		
Differential Input Voltage for LVDS Receiver Threshold	High	V_{IH}	-	-	+100	mV	$V_{CM} = +1.2V$
	Low	V_{IL}	-100	-	-	mV	
Vsync Frequency	f_V	-	60	-	Hz		
Hsync Frequency	f_H	-	37.9	-	KHz		
Main Frequency	f_{DCLK}	38	40	42	MHz		
Rush Current	I_{RUSH}	-	-	1.5	A	(4)	
Current of Power Supply	White	I_{DD}	-	220	-	mA	(2),(3)*a
	Mosaic		-	250	-	mA	(2),(3)*b
	V.stripe		-	340	360	mA	(2),(3)*c

Note (1) Display data pins and timing signal pins should be connected.(GND=0V)

(2) $f_V = 60\text{Hz}$, $f_{DCLK} = 40\text{MHz}$, $V_{DD} = 3.3V$, DC Current.

(3) Power dissipation pattern

*a) White Pattern

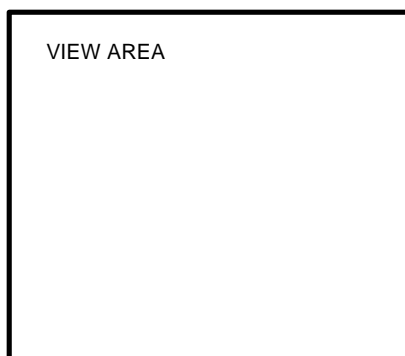

*b) Mosaic Pattern

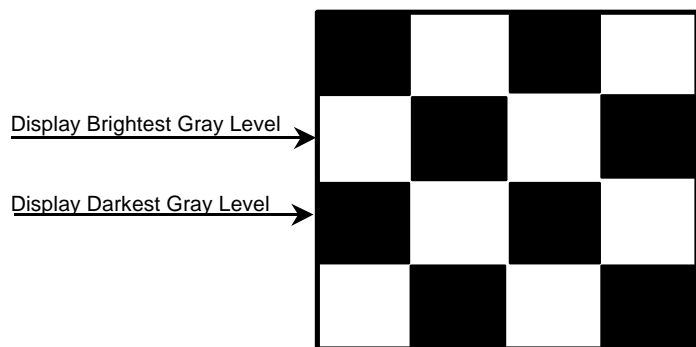

*c) Vertical stripe pattern

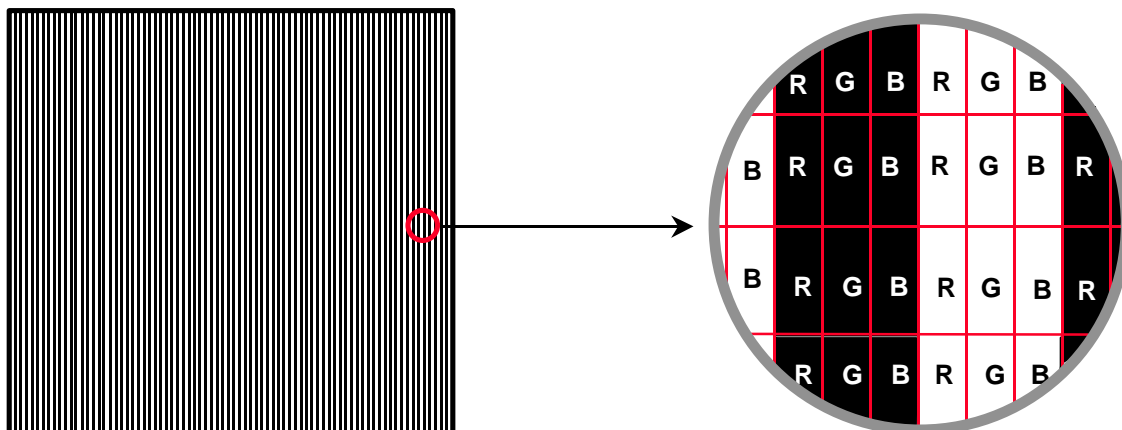

4) Rush current measurement condition

Vdd rising time : 470µs

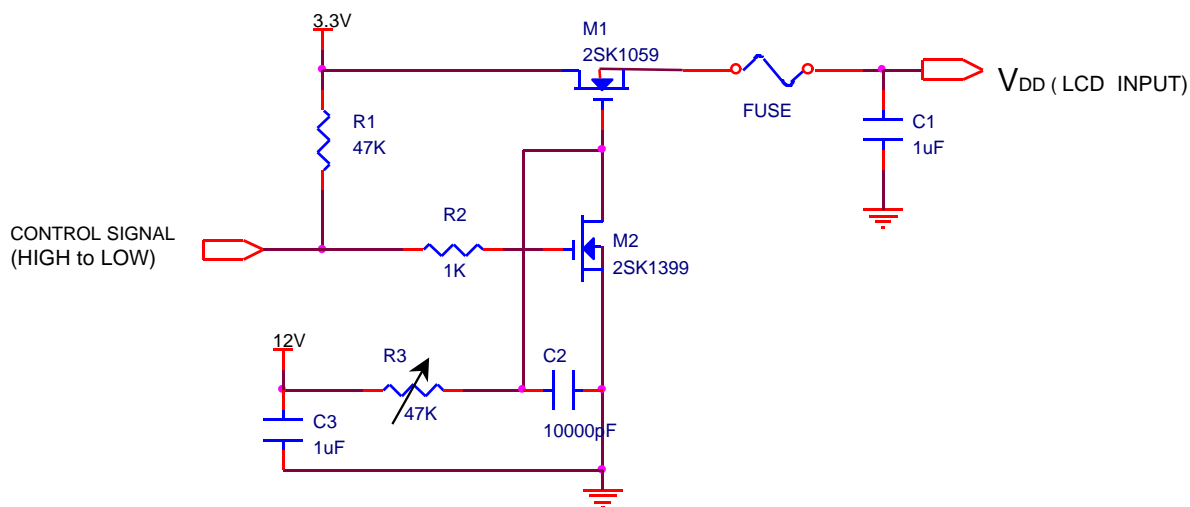

Vdd rising time is 470us

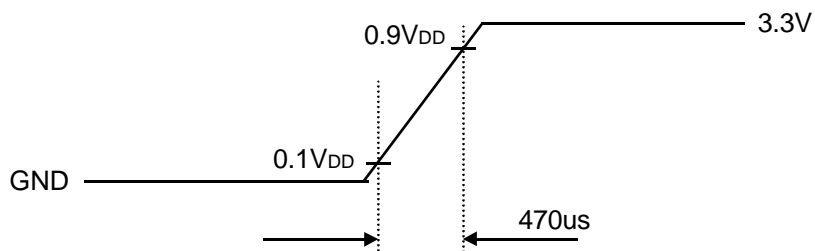

3.2 BACK-LIGHT UNIT

The backlight system is an edge - lighting type with a single CCFT (Cold Cathode Fluorescent Tube).
The characteristics of a single lamp are shown in the following tables.

INVERTER : SEM SIC-130

$T_a = 25 \pm 2 \text{ } ^\circ\text{C}$

ITEM	SYMBOL	MIN	TYP	MAX	UNIT	NOTE
Lamp Current	I_L	3.0	5.0	6.0	mArms	(1)
Lamp Voltage	V_L	-	660	-	Vrms	$I_L = 5.0\text{mA}$
Frequency	f_L	40	-	60	KHz	(2)
Power Consumption	P_L	-	3.3	-	W	(3) $I_L = 5.0\text{mA}$
Operating Life Time	Hr	10,000	-	-	Hour	(4)
Startup Voltage	V_s	-	-	1050 (25 °C)	Vrms	(5)
				1400 (0 °C)		

Note) The waveform of the inverter output voltage must be area symmetric and the design of the inverter must have specifications for the modularized lamp.

The performance of the backlight, for example life time or brightness, is much influenced by the characteristics of the DC-AC inverter for the lamp. So all the parameters of an inverter should be carefully designed so as not to produce too much leakage current from high-voltage output of the inverter. When you design or order the inverter, please make sure that a poor lighting caused by the mismatch of the backlight and the inverter (miss lighting, flicker, etc.) never occur. When you confirm it, the module should be operated in the same condition as it is installed in your instrument.

Note (1) Lamp current is measured with a high frequency current meter as shown below.

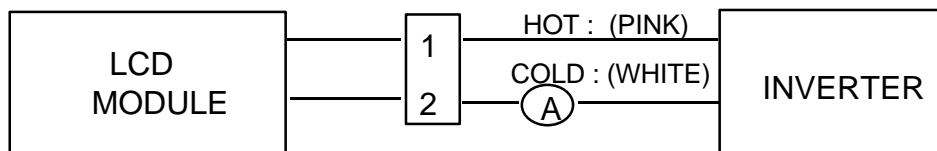

No 2 Pin is VLow.

(2) Lamp frequency may produce interference with horizontal synchronous frequency and this may cause line flow on the display. Therefore lamp frequency should be detached from the horizontal synchronous frequency and its harmonics as far as possible in order to avoid interference.

(3) refer to I_L ; V_L to calculate.

(4) Life time (Hr) of a lamp can be defined as the time in which it continues to operate under the condition $T_a = 25 \pm 2 \text{ } ^\circ\text{C}$ and $I_L = 6.0 \text{ mArms}$ until one of the following event occurs.

1. When the brightness becomes 50% or lower than the original.

2. When the Effective ignition length becomes 80% or lower than the original value.

(Effective ignition length is defined as an area that has less than 70% brightness compared to the brightness in the center point.)

(5) The voltage above this value should be applied to the lamp for more than 1 second to startup. Otherwise the lamp may not be turned on.

4. BLOCK DIAGRAM

4.1 TFT LCD Module

Connector : JAE FI-SEB20P-HF

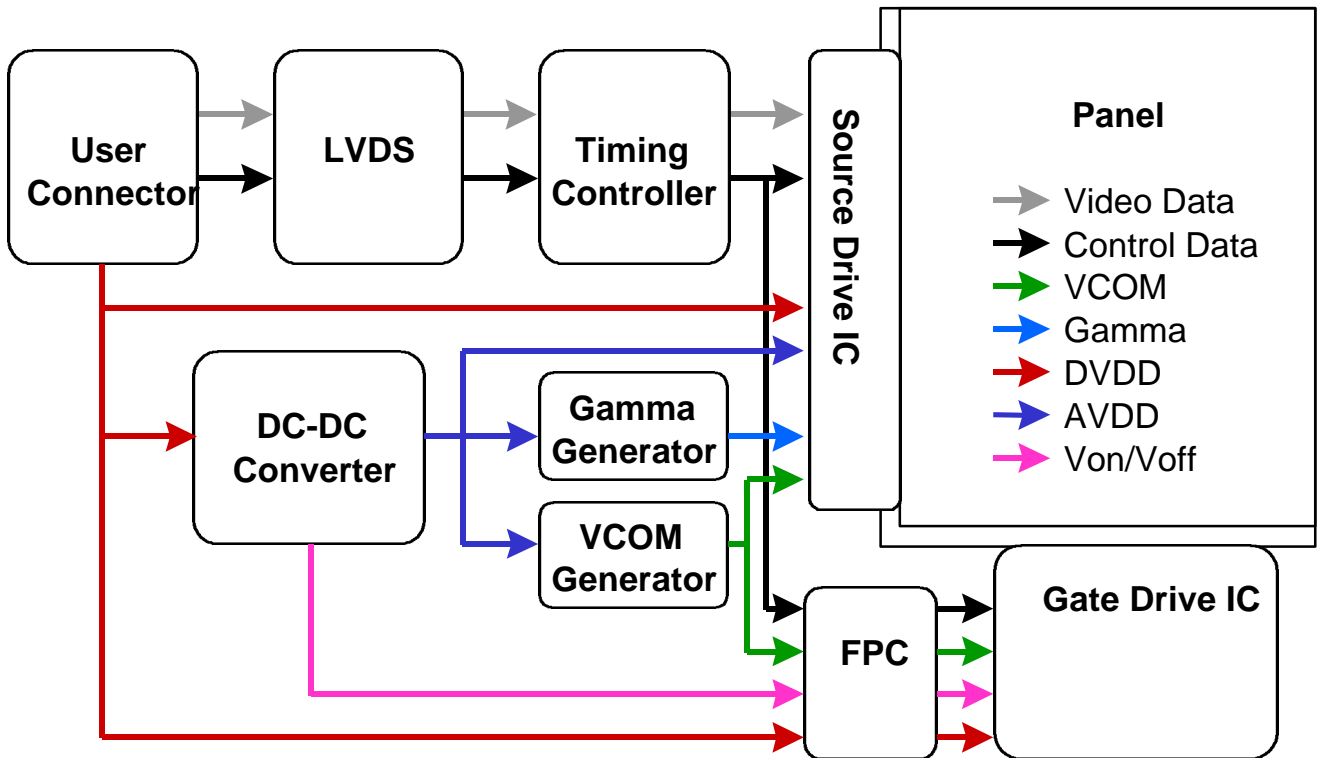

4.2 BACK-LIGHT UNIT

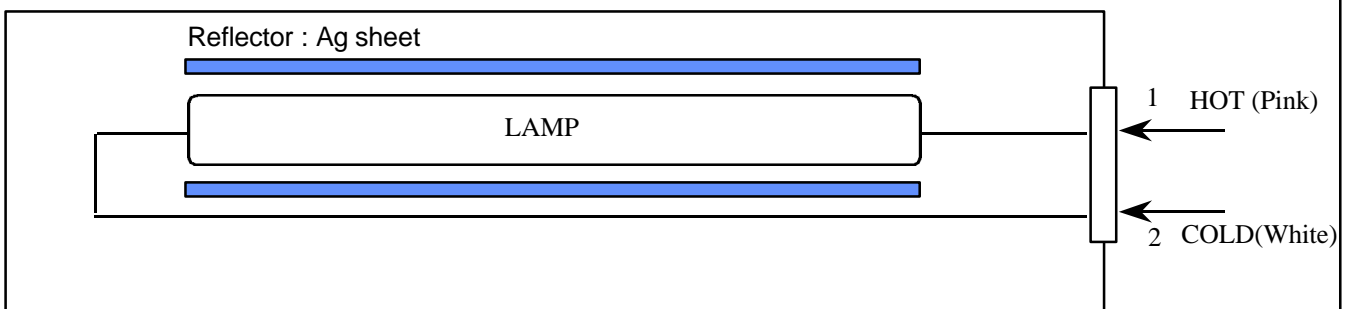

Note) The output of the inverter may change according to the material of the reflector.

5. INPUT TERMINAL PIN ASSIGNMENT

Approval

5.1. Input Signal & Power (LVDS, Connector : JAE, F1-SEB20P-HF10
Mating Connector : FI-SE20MR or FI-SE20M)

Pin NO.	Symbol	Function	Polarity	Remark
1	V _{DD}	Power Supply +3.3V		Pixel clock (40MHz)
2	V _{DD}			
3	GND	Power Ground		
4	GND			
5	Y0M	Receiver Signal(-)	Negative	
6	Y0P	Receiver Signal(+)	Positive	
7	GND	Power Ground		
8	Y1M	Receiver Signal(-)	Negative	
9	Y1P	Receiver Signal(+)	Positive	
10	GND	Power Ground		
11	Y2M	Receiver Signal(-)	Negative	
12	Y2P	Receiver Signal(+)	Positive	
13	GND	Power Ground		
14	CLKOUTM	clock Signal(-)	Negative	
15	CLKOUTP	clock Signal(+)	Positive	
16	GND	Power Ground		
17	N.C.			
18	N.C.			
19	GND	Power Ground		
20	GND			

5.2 LVDS Transmitter : SN75LVDS83(Ti) or Compatible

Pin No.	Name	RGB Signal	Pin No.	Name	RGB Signal
51	D0	R0	14	D14	G5
52	D1	R1	15	D15	B0
54	D2	R2	19	D19	B1
55	D3	R3	20	D20	B2
56	D4	R4	22	D22	B3
3	D6	R5	23	D23	B4
4	D7	G0	24	D24	B5
6	D8	G1	27	D27	Hsync
7	D9	G2	28	D28	Vsync
11	D12	G3	30	D30	DE
12	D13	G4	31	CLKIN	Clock

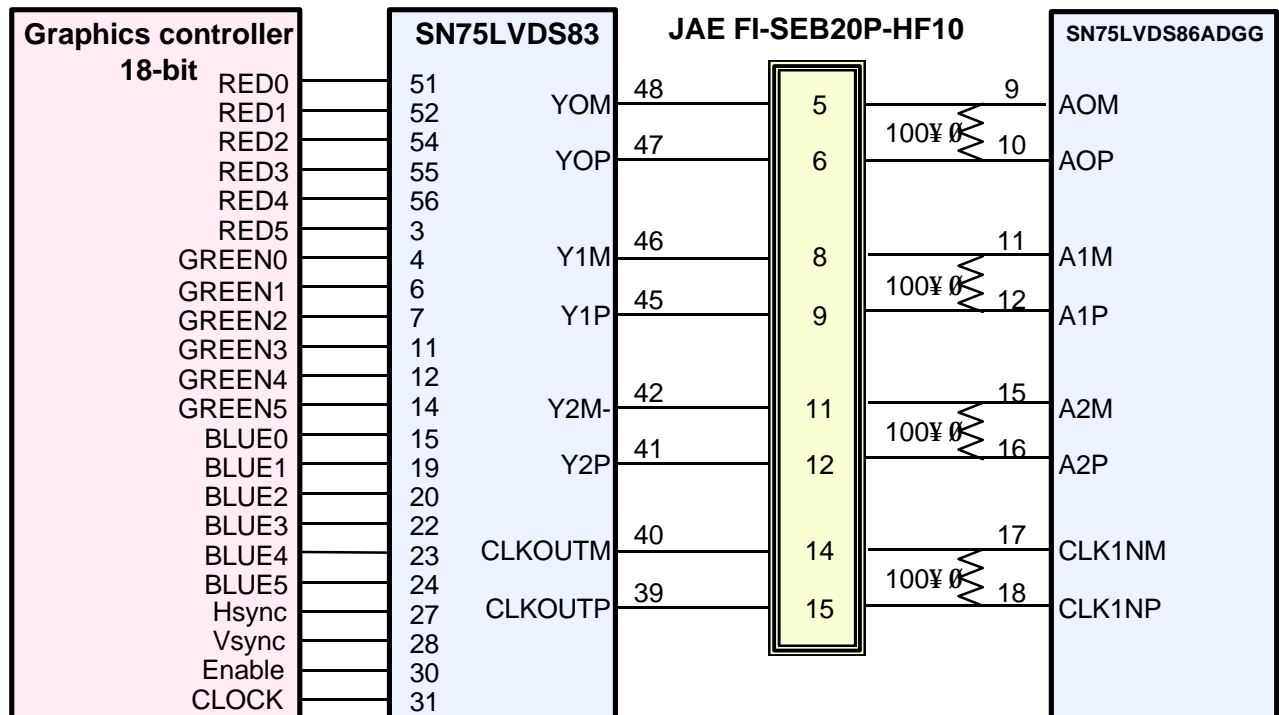
FLAT LINK INTERFACE

Note : The LCD Module uses a 100ohm resistor between positive and negative lines of each receiver input.

5.3 Input Signals, Basic Display Colors and Gray Scale of Each Color

COLOR	DISPLAY	DATA SIGNAL																	GRAY SCALE LEVEL	
		RED					GREEN					BLUE								
		R0	R1	R2	R3	R4	R5	G0	G1	G2	G3	G4	G5	B0	B1	B2	B3	B4		B5
BASIC COLOR	BLACK	0	0	0	0	0	0	0	0	0	0	0	0	0	0	0	0	0	0	-
	BLUE	0	0	0	0	0	0	0	0	0	0	0	0	1	1	1	1	1	1	-
	GREEN	0	0	0	0	0	0	1	1	1	1	1	1	0	0	0	0	0	0	-
	CYAN	0	0	0	0	0	0	1	1	1	1	1	1	1	1	1	1	1	1	-
	RED	1	1	1	1	1	1	0	0	0	0	0	0	0	0	0	0	0	0	-
	MAGENTA	1	1	1	1	1	1	0	0	0	0	0	0	1	1	1	1	1	1	-
	YELLOW	1	1	1	1	1	1	1	1	1	1	1	1	0	0	0	0	0	0	-
WHITE	1	1	1	1	1	1	1	1	1	1	1	1	1	1	1	1	1	1	-	
GRAY SCALE OF RED	BLACK	0	0	0	0	0	0	0	0	0	0	0	0	0	0	0	0	0	0	R0
	DARK jè	1	0	0	0	0	0	0	0	0	0	0	0	0	0	0	0	0	0	R1
		0	1	0	0	0	0	0	0	0	0	0	0	0	0	0	0	0	0	R2
		:	:	:	:	:	:	:	:	:	:	:	:	:	:	:	:	:	:	R3-R60
		:	:	:	:	:	:	:	:	:	:	:	:	:	:	:	:	:	:	
	jé LIGHT	1	0	1	1	1	1	0	0	0	0	0	0	0	0	0	0	0	0	R61
		0	1	1	1	1	1	0	0	0	0	0	0	0	0	0	0	0	0	R62
RED	1	1	1	1	1	1	0	0	0	0	0	0	0	0	0	0	0	0	R63	
GRAY SCALE OF GREEN	BLACK	0	0	0	0	0	0	0	0	0	0	0	0	0	0	0	0	0	0	G0
	DARK jè	0	0	0	0	0	0	1	0	0	0	0	0	0	0	0	0	0	0	G1
		0	0	0	0	0	0	0	1	0	0	0	0	0	0	0	0	0	0	G2
		:	:	:	:	:	:	:	:	:	:	:	:	:	:	:	:	:	:	G3-G60
		:	:	:	:	:	:	:	:	:	:	:	:	:	:	:	:	:	:	
	jé LIGHT	0	0	0	0	0	0	1	0	1	1	1	1	0	0	0	0	0	0	G61
		0	0	0	0	0	0	0	1	1	1	1	1	0	0	0	0	0	0	G62
GREEN	0	0	0	0	0	0	1	1	1	1	1	1	0	0	0	0	0	0	G63	
GRAY SCALE OF BLUE	BLACK	0	0	0	0	0	0	0	0	0	0	0	0	0	0	0	0	0	0	B0
	DARK jè	0	0	0	0	0	0	0	0	0	0	0	0	1	0	0	0	0	0	B1
		0	0	0	0	0	0	0	0	0	0	0	0	0	1	0	0	0	0	B2
		:	:	:	:	:	:	:	:	:	:	:	:	:	:	:	:	:	:	B3-B60
		:	:	:	:	:	:	:	:	:	:	:	:	:	:	:	:	:	:	
	jé LIGHT	0	0	0	0	0	0	0	0	0	0	0	0	1	0	1	1	1	1	B61
		0	0	0	0	0	0	0	0	0	0	0	0	0	1	1	1	1	1	B62
BLUE	0	0	0	0	0	0	0	0	0	0	0	0	1	1	1	1	1	1	B63	

Note 1) Definition of gray :

Rn: Red gray, Gn: Green gray, Bn: Blue gray (n=gray level)

Note 2) Input signal: 0 =Low level voltage, 1=High level voltage

5.4 BACK LIGHT UNIT

Connector : JST BHSR - 02VS -01

Pin NO.	Symbol	Color	Function
1	HOT	Pink	High Voltage
2	COLD	White	Low Voltage

5.5 Pixel Format in the display

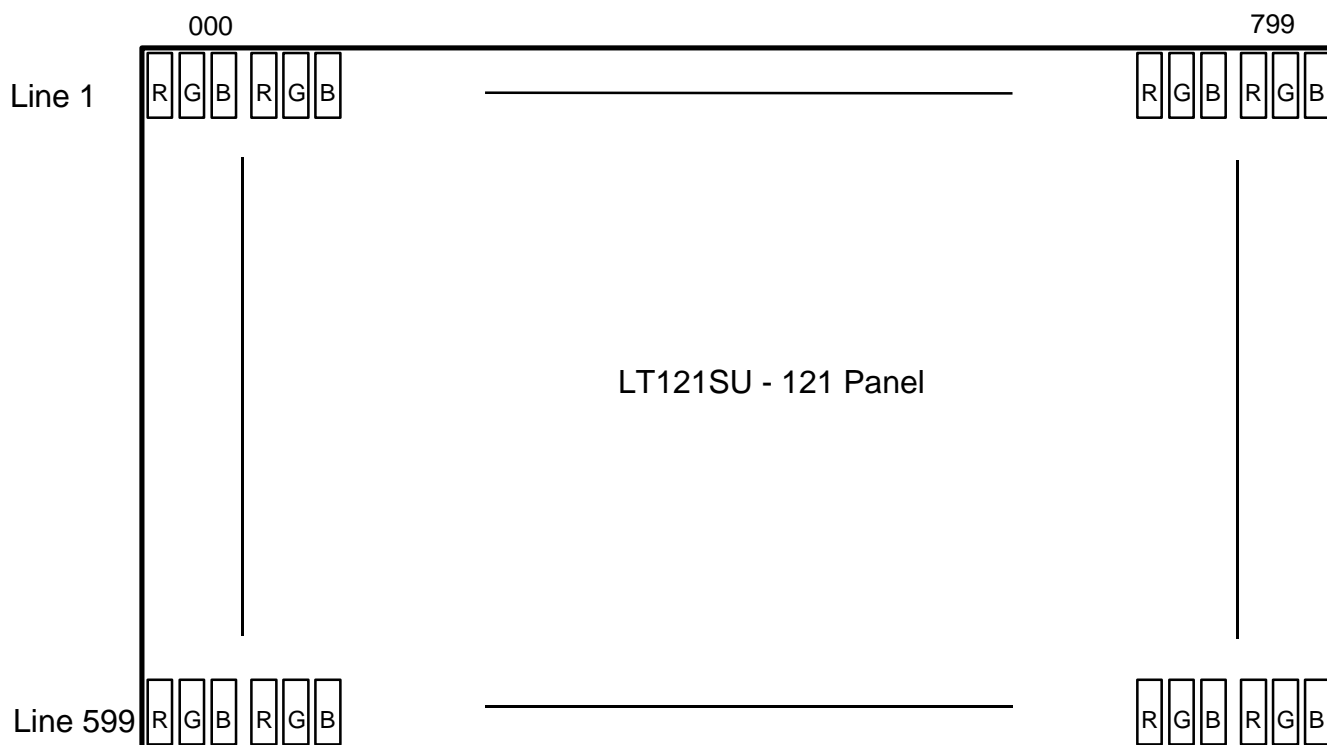

6. INTERFACE TIMING

6.1 Timing Parameters

Signal	Item	Symbol	MIN	TYP	MAX	Unit	Note
Clock	Frequency	$1 / T_C$	38	40	42	MHz	
	High Time	T_{CH}	5	-	-	nsec	
	Low Time	T_{CL}	5	-	-	nsec	
Data	Setup Time	T_{DS}	5	-	-	nsec	
	Hold Time	T_{DH}	5	-	-	nsec	
Data Enable	Setup Time	T_{ES}	5	-	-	nsec	(1)
Frame Frequency	Cycle	T_V	620	628	664	lines	
Vertical Active Display Term	Display Period	T_{VD}	-	600	-	lines	
One Line Scanning Time	Cycle	T_H	1024	1056	1056	clocks	(2)
Horizontal Active Display Term	Display Period	T_{HD}	-	800	-	clocks	

Note (1) When the VGA controller sets DE only mode, Hsync and Vsync should be set low logic level or ground.

(2) The duration of DE [DTMG] signal must be longer than 1 clock period at every horizontal sync. period

6.2 Timing diagrams of interface signal

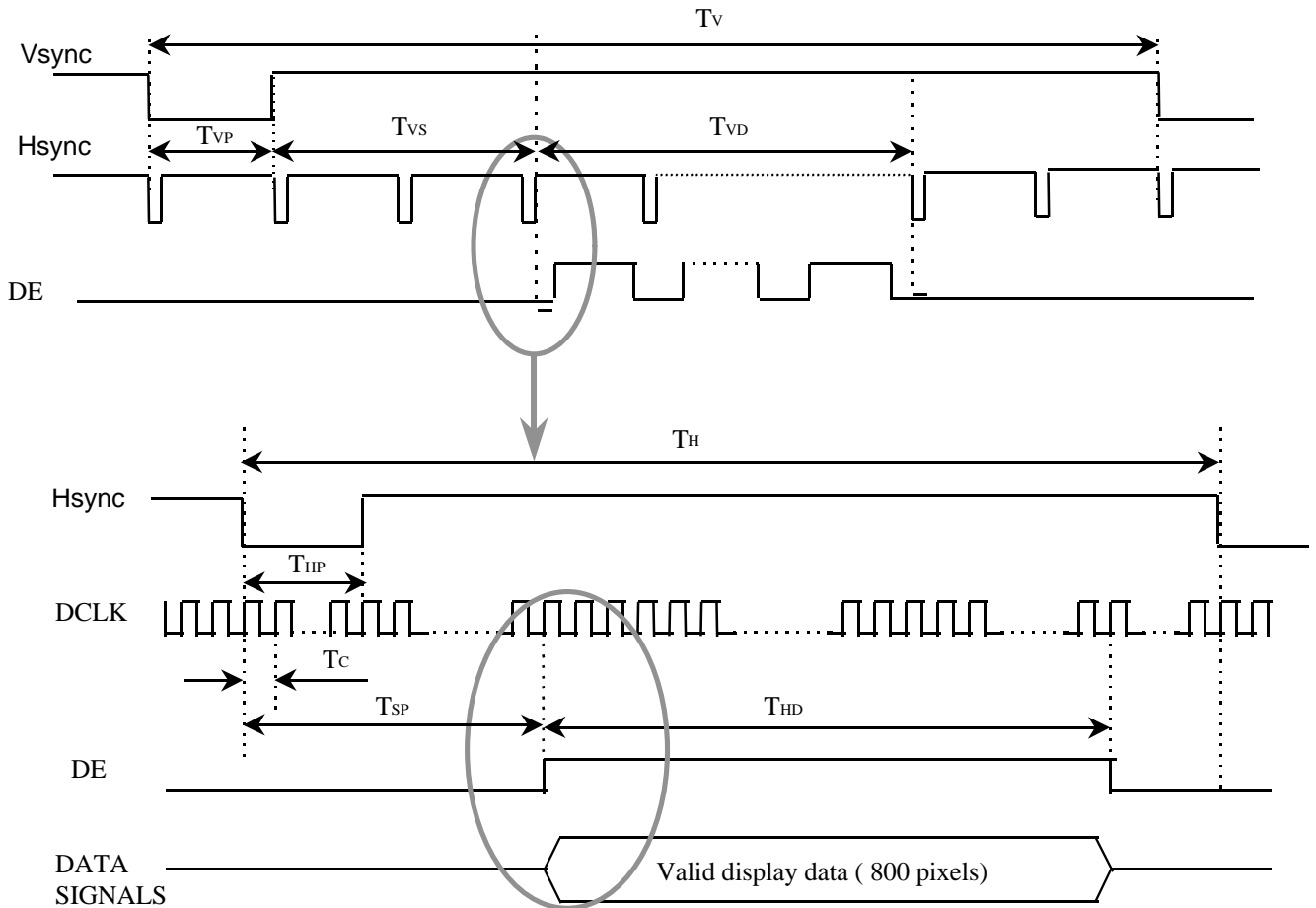

- Signal Transition Timing

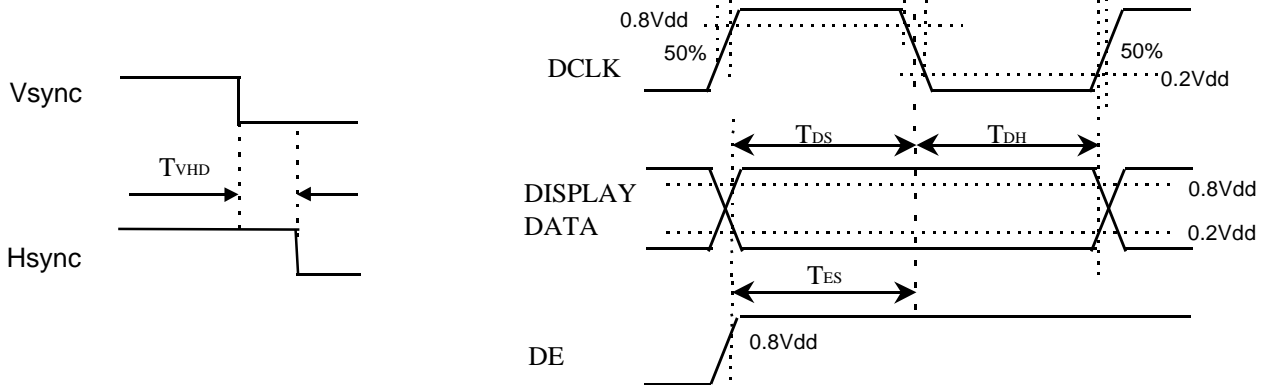

6.3 Power ON/OFF Sequence

: To prevent a latch-up or DC operation of the LCD module, the power on/off sequence shall be as shown below.

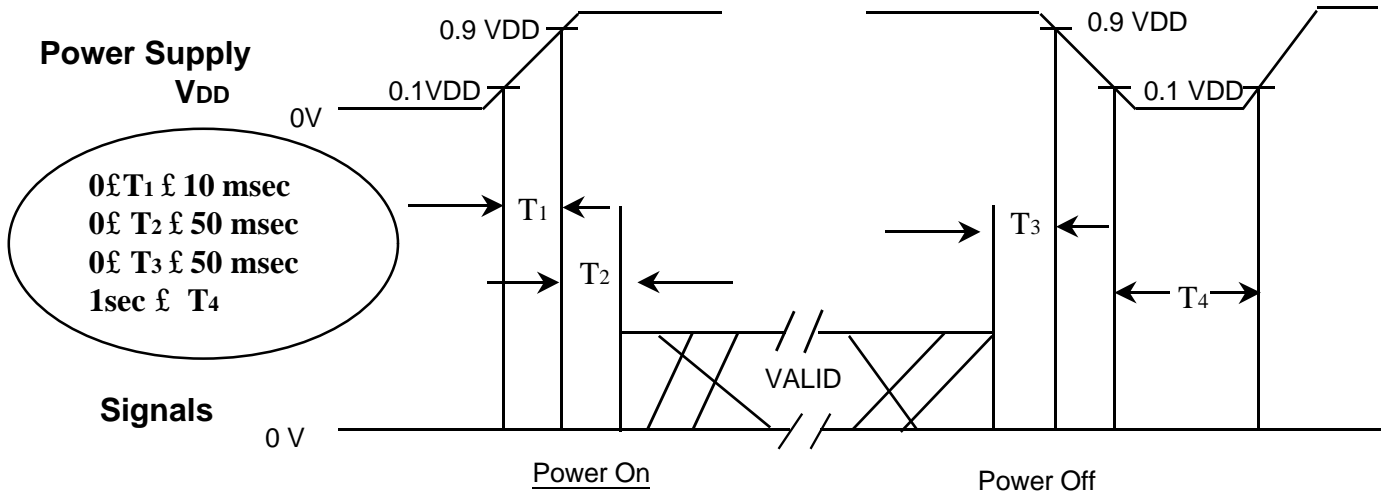

NOTE.

- (1) The supply voltage of the external system for the module input should be the same as the definition of VDD.
- (2) Apply the lamp voltage within the LCD operation range. When the backlight turns on before the LCD operation or the LCD turns off before the backlight turns off, the display may momentarily become white.
- (3) In case of VDD = off level, please keep the level of input signals on the low or keep a high impedance.
- (4) T4 should be measured after the module has been fully discharged between power off and on period.
- (5) Interface signal shall not be kept at high impedance when the power is on.

7. Mechanical Outline Dimension

Approval

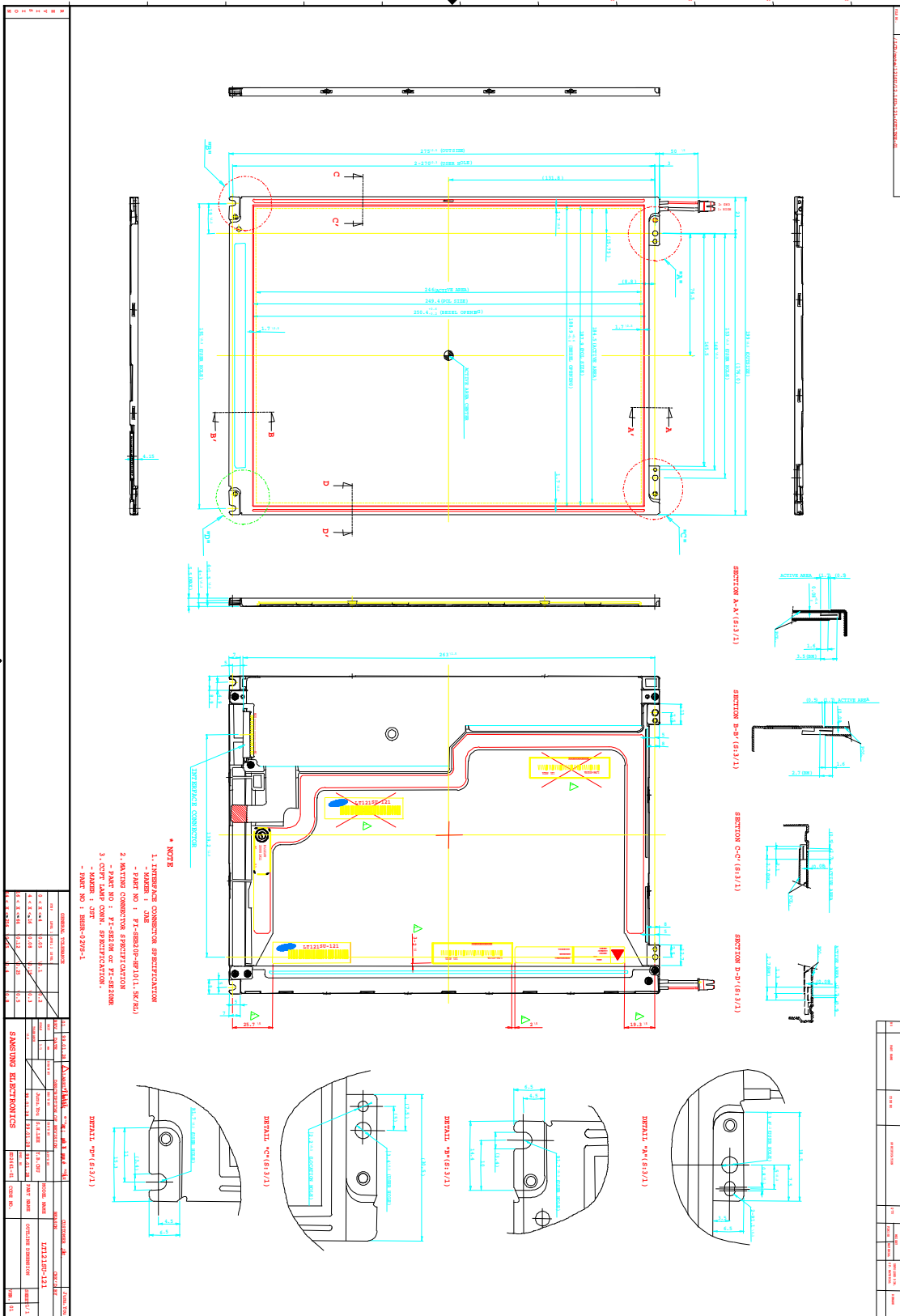

8. GENERAL PRECAUTIONS

1. Handling

- (a) When the module is assembled, It should be attached to the system firmly using every mounting holes. Be careful not to twist and bend the modules.
- (b) Refrain from strong mechanical shock and / or any force to the module. In addition to damage, this may cause improper operation or damage to the module and CCFT backlight.
- (c) Note that polarizers are very fragile and could be easily damaged. Do not press or scratch the surface harder than a HB pencil lead.
- (d) Wipe off water droplets or oil immediately. If you leave the droplets for a long time, Staining and discoloration may occur.
- (e) If the surface of the polarizer is dirty, clean it using some absorbent cotton or soft cloth.
- (f) The desirable cleaners are water, IPA(Isoprophyl Alcohol) or Hexane. Do not use Ketone type materials(ex. Acetone), Ethyl alcohol, Toluene, Ethyl acid or Methyl chloride. It might permanent damage to the polarizer due to chemical reaction.
- (g) If the liquid crystal material leaks from the panel, it should be kept away from the eyes or mouth . In case of contact with hands, legs or clothes, it must be washed away thoroughly with soap.
- (h) Protect the module from static , it may cause damage to the C-MOS Gate Array IC.
- (i) Use fingerstalls with soft gloves in order to keep display clean during the incoming inspection and assembly process.
- (j) Do not disassemble the module.
- (k) Do not pull or fold the lamp wire.
- (l) Do not adjust the variable resistor which is located on the back side.
- (m) Protection film for polarizer on the module shall be slowly peeled off just before use so that the electrostatic charge can be minimized.
- (n) Pins of I/F connector shall not be touched directly with bare hands.

2. STORAGE

- (a) Do not leave the module in high temperature, and high humidity for a long time. It is highly recommended to store the module with temperature from 0 to 35 ; and relative humidity of less than 70%.
- (b) Do not store the TFT-LCD module in direct sunlight.
- (c) The module shall be stored in a dark place. It is prohibited to apply sunlight or fluorescent light during the store.

3. OPERATION

- (a) Do not connect,disconnect the module in the “ Power On” condition.
- (b) Power supply should always be turned on/off by following item 6.3 “ Power on/off sequence “.
- (c) Module has high frequency circuits. Sufficient suppression to the electromagnetic interference shall be done by system manufacturers. Grounding and shielding methods may be important to minimize the interference.
- (d) The cable between the backlight connector and its inverter power supply shall be a minimized length and be connected directly . The longer cable between the backlight and the inverter may cause lower luminance of lamp(CCFT) and may require higher startup voltage(Vs).

4. OTHERS

- (a) Ultra-violet ray filter is necessary for outdoor operation.
- (b) Avoid condensation of water. It may result in improper operation or disconnection of electrode.
- (c) Do not exceed the absolute maximum rating value. (the supply voltage variation, input voltage variation, variation in part contents and environmental temperature, so on) Otherwise the module may be damaged.
- (d) If the module displays the same pattern continuously for a long period of time,it can be the situation when the image “sticks” to the screen.
- (e) This module has its circuitry PCB's on the rear side and should be handled carefully in order not to be stressed.