

PREPARED BY : DATE	<h1>SHARP</h1> <p>MOBILE LIQUID CRYSTAL DISPLAY GROUP SHARP CORPORATION</p> <h2>SPECIFICATION</h2>	SPEC No. LD-20411
APPROVED BY : DATE		FILE No.
		ISSUE : Apr. 23. 2008
		PAGE : 21 pages
		APPLICABLE GROUP MOBILE LIQUID CRYSTAL DISPLAY GROUP

DEVICE SPECIFICATION FOR
TFT-LCD Module
 MODEL No.
LQ190E1LW02

These parts have corresponded with the RoHS directive.

CUSTOMER'S APPROVAL

DATE _____

BY _____

PRESENTED

BY *K. Shiono*

K. Shiono
 General manager
 ENGINEERING DEPARTMENT
 MOBILE LIQUID CRYSTAL DISPLAY DIVISION III
 MOBILE LIQUID CRYSTAL DISPLAY GROUP
 SHARP CORPORATION

1. Application

This specification sheets applies to the color TFT-LCD module LQ190E1LW02.

These specification sheets are the proprietary product of SHARP CORPORATION ("SHARP") and include materials protected under copyright of SHARP. Do not reproduce or cause any third party to reproduce them in any form or by any means, electronic or mechanical, for any purpose, in whole or in part, without the express written permission of SHARP.

The application example published in this specification sheets is used to explain a typical application example that uses the product of our company. It is not the one to permit the guarantee or the execution right to the execution of an industrial property and other right according to this technological material. Moreover, SHARP assumes no responsibility for any problem related to the third party and the industrial property, etc. occurring by having used the product of our company.

The device listed in these specification sheets was designed and manufactured for use in general electronic equipment.

In case of using the device for applications such as control and safety equipment for transportation (controls of aircraft, trains, automobiles, etc.), rescue and security equipment and various safety related equipment which require higher reliability and safety, take into consideration that appropriate measures such as fail-safe functions and redundant system design should be taken.

Do not use the device for equipment that requires an extreme level of reliability, such as aerospace applications, telecommunication equipment (trunk lines), nuclear power control equipment and medical or other equipment for life support.

SHARP assumes no responsibility for any damage resulting from the use of the device which does not comply with the instructions and the precautions specified in these specification sheets .

Confirm "11. Handling Precautions " item when you use the device.

Contact and consult with a SHARP sales representative for any questions about this device.

2. Overview

This module is a color active matrix LCD module incorporating amorphous silicon TFT (Thin Film Transistor). It is composed of a color TFT-LCD panel, driver ICs, control circuit, power supply circuit and a back light unit. Graphics and texts can be displayed on a 1280 × RGB × 1024 dots panel with about 16,777,216 colors by using LVDS (Low Voltage Differential Signaling) and supplying +5.0V DC supply voltages for TFT-LCD panel driving and supply voltage for backlight.

It is a wide viewing-angle-module and color filters (NTST72%) of excellent color performance.

Backlight-driving DC/AC inverter is not built in this module.

3. Mechanical Specifications

Parameter	Specifications	Unit
Display size	48 (19.0") Diagonal	cm
Active area	376.32 (H) × 301.056 (V)	mm
Pixel format	1280 (H) × 1024 (V)	Pixel
	(1 pixel = R+G+B dots)	
Aspect ratio	5:4	
Pixel pitch	0.294 (H) × 0.294 (V)	mm
Pixel configuration	R, G, B vertical stripe	
Display mode	Normally black	
Unit outline dimensions *1	404.2(W) × 330.0(H) × 20.0(D)TYP	mm
Mass	2,800 (max)	g
Surface treatment (Haze value)	Anti-glare coating : (Haze value 40%, Hardness 2H)	

*1.Note: excluding back light cables and connectors.

The thickness of module (D) doesn't contain the projection.

Outline dimensions are shown in Fig.1.

4. Input Terminals

4-1. TFT-LCD panel driving

CN1 (Interface signals and +5.0V power supply)

- Using connectors : FI-X30SSL-HF (Japan Aviation Electronics Industry, Limited)
 Corresponding connectors : FI-X30M (FPC type) (Japan Aviation Electronics Industry, Limited)
 : FI-X30H (Wire type), FI-X30HL(Wire type with lock)
 : FI-X30C (Coaxial cable type), FI-X30C2L(Coaxial cable type with luck)
- Using LVDS receiver : Type contained in a control IC
 (DS90CF386 (NS Corporation) or equivalent)

Corresponding LVDS Transmitter : DS90CF383, C385 (NS Corporation) or equivalent)

Pin No.	Symbol	Function	Remark
1	RxO0-	Receiver signal of LVDS (O0-)	LVDS
2	RxO0+	Receiver signal of LVDS (O0+)	LVDS
3	RxO1-	Receiver signal of LVDS (O1-)	LVDS
4	RxO1+	Receiver signal of LVDS (O1+)	LVDS
5	RxO2-	Receiver signal of LVDS (O2-)	LVDS
6	RxO2+	Receiver signal of LVDS (O2+)	LVDS
7	GND	GND	
8	RxOC-	Receiver signal of LVDS (OC-)	LVDS
9	RxOC+	Receiver signal of LVDS (OC+)	LVDS
10	RxO3-	Receiver signal of LVDS (O3-)	LVDS
11	RxO3+	Receiver signal of LVDS (O3+)	LVDS
12	RxE0-	Receiver signal of LVDS (E0-)	LVDS
13	RxE0+	Receiver signal of LVDS (E0+)	LVDS
14	GND	GND	
15	RxE1-	Receiver signal of LVDS (E1-)	LVDS
16	RxE1+	Receiver signal of LVDS (E1+)	LVDS
17	GND	GND	
18	RxE2-	Receiver signal of LVDS (E2-)	LVDS
19	RxE2+	Receiver signal of LVDS (E2+)	LVDS
20	RxEC-	Receiver signal of LVDS (EC-)	LVDS
21	RxEC+	Receiver signal of LVDS (EC+)	LVDS
22	RxE3-	Receiver signal of LVDS (E3-)	LVDS
23	RxE3+	Receiver signal of LVDS (E3+)	LVDS
24	GND	GND	
25	SEL LVDS	Selection of LVDS mapping	
26	N.C.		
27	N.C.		
28	Vcc	+5V power supply	
29	Vcc	+5V power supply	
30	Vcc	+5V power supply	

Note: There is a possibility that trouble occurs in initial and long-term reliability when using it besides corresponding connector.

4-2. Data Mapping

1) 8 bit input

【Note 1】 pin assignment with LVDS_SET pin

Transmitter: DS90CF383, C385 (NS Corporation) or equivalent

Transmitter		25pin SELLVDS	
Pin No	Data	= H (3.3V)	= L (GND) or Open
51	TA0	R0 (LSB)	R2
52	TA1	R1	R3
54	TA2	R2	R4
55	TA3	R3	R5
56	TA4	R4	R6
3	TA5	R5	R7 (MSB)
4	TA6	G0 (LSB)	G2
6	TB0	G1	G3
7	TB1	G2	G4
11	TB2	G3	G5
12	TB3	G4	G6
14	TB4	G5	G7 (MSB)
15	TB5	B0 (LSB)	B2
19	TB6	B1	B3
20	TC0	B2	B4
22	TC1	B3	B5
23	TC2	B4	B6
24	TC3	B5	B7 (MSB)
27	TC4	(NA)	(NA)
28	TC5	(NA)	(NA)
30	TC6	DE	DE
50	TD0	R6	R0 (LSB)
2	TD1	R7 (MSB)	R1
8	TD2	G6	G0 (LSB)
10	TD3	G7 (MSB)	G1
16	TD4	B6	B0 (LSB)
18	TD5	B7 (MSB)	B1
25	TD6	(NA)	(NA)

< SELLVDS = H >

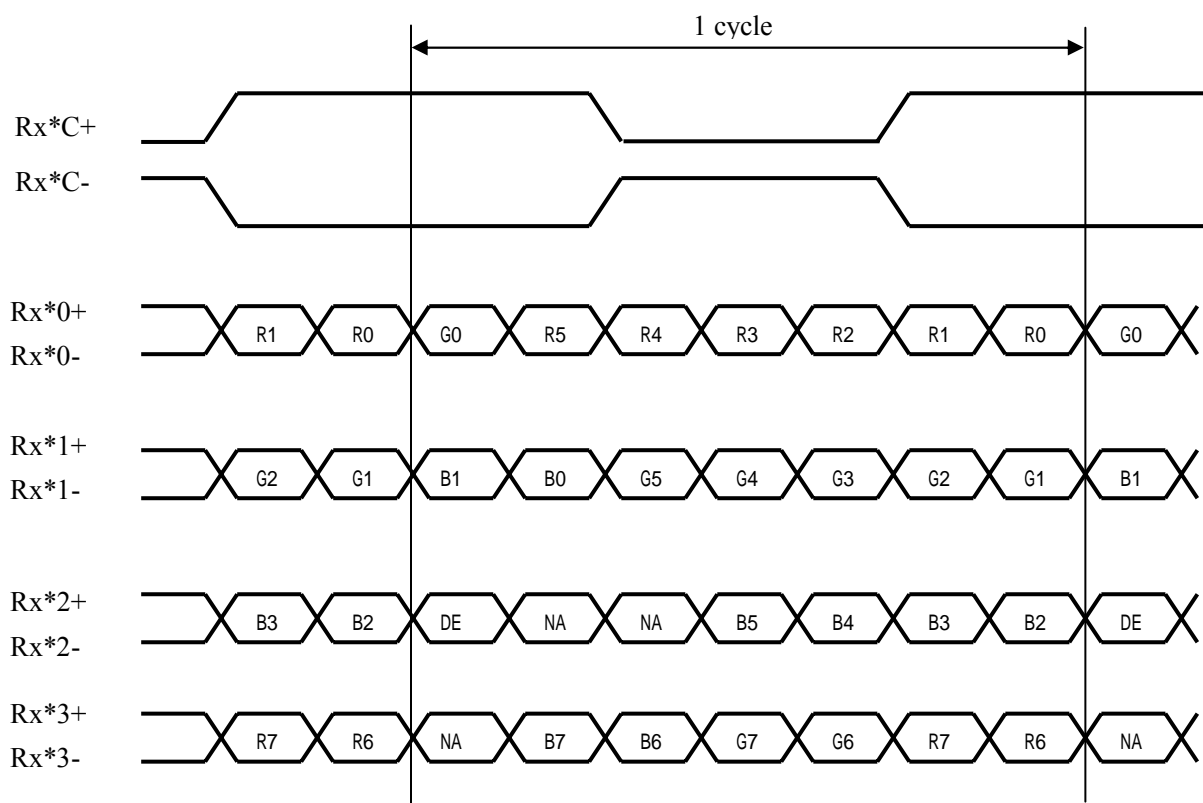

* : 0 or D

DE : Display Enable

NA : Not Available

< SELLVDS=L or Open >

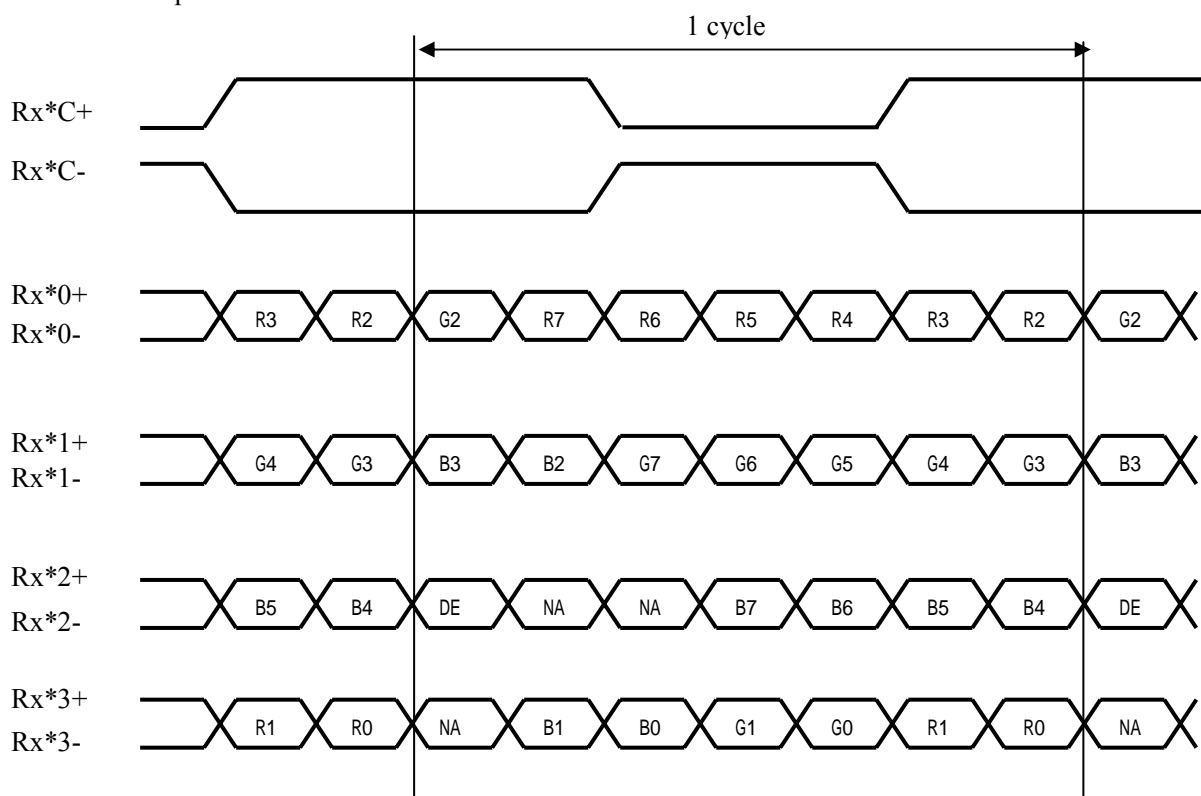

* : or E

DE : Display Enable

NA : Not Available

LVDS Interface block diagram

(Computer Side)

(TFT-LCD side)

① SEL LVDS=H (25 pin=3.3[V])

ODD DATA

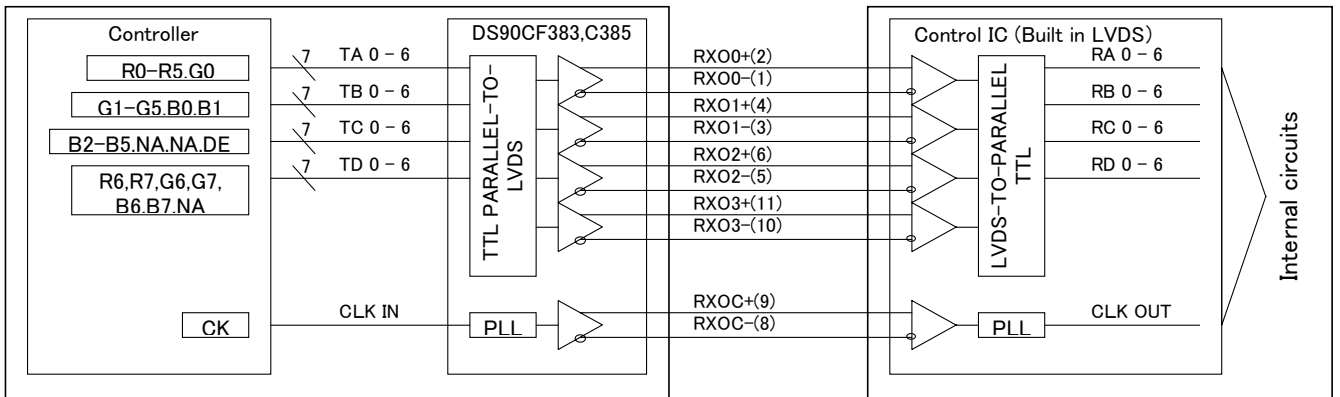

EVEN DATA

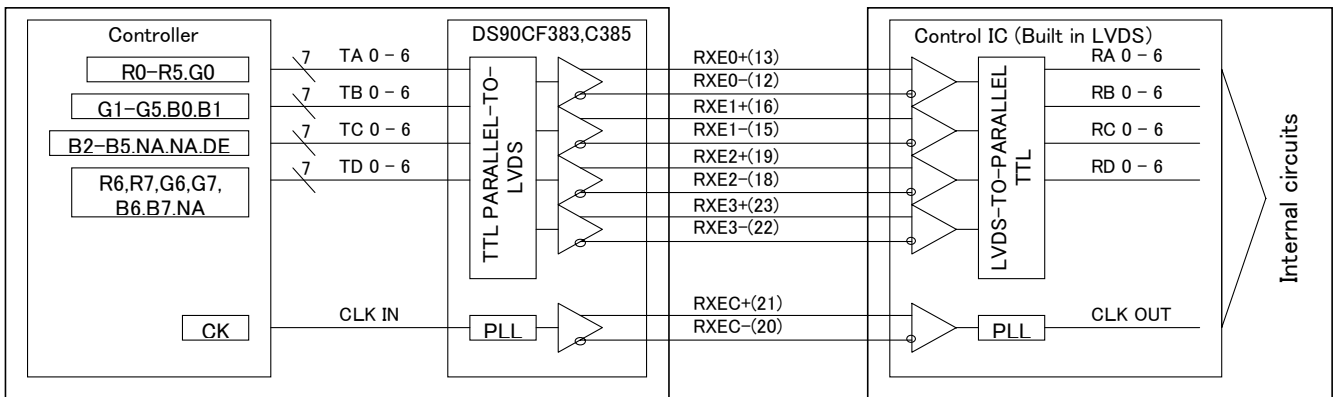

② SEL LVDS=L (25 pin=GND or OPEN)

ODD DATA

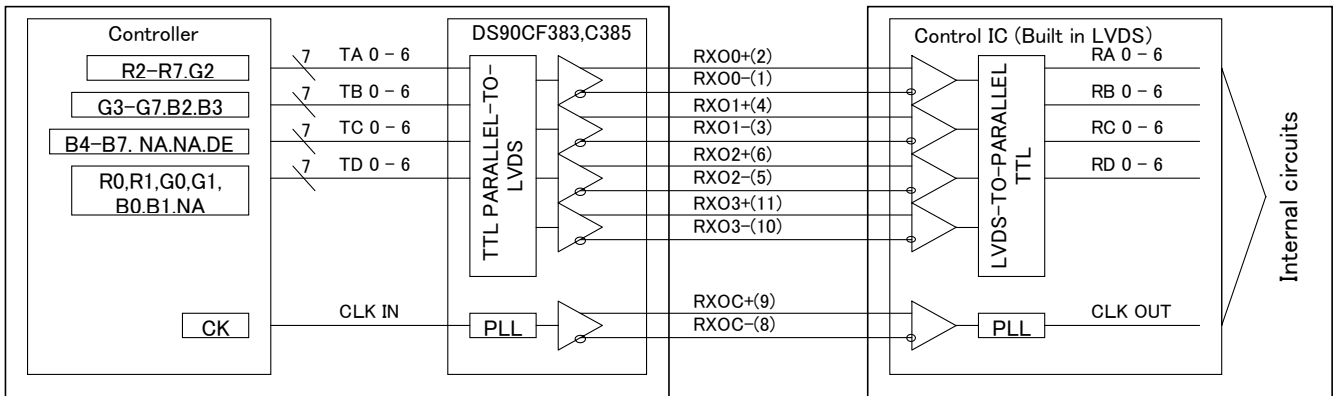

EVEN DATA

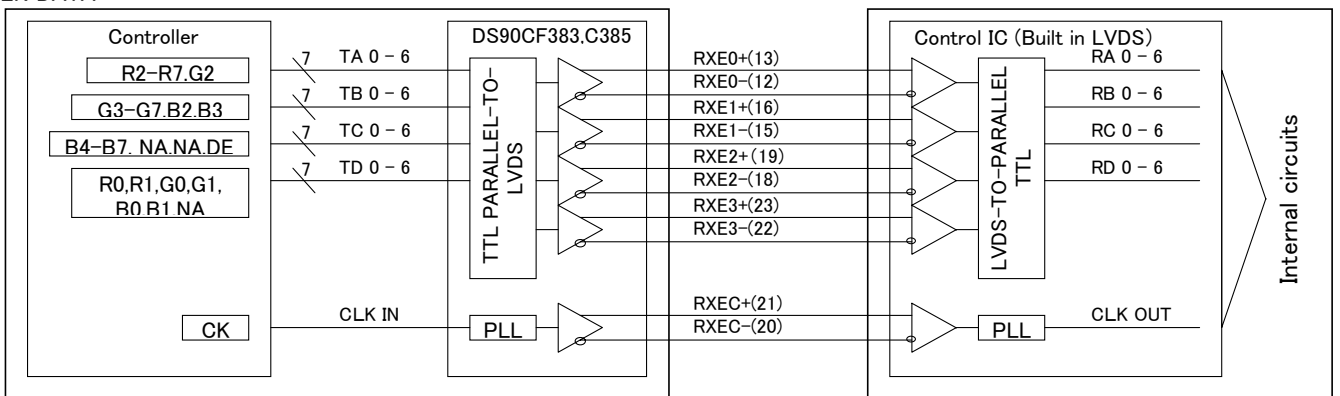

* NA: Not Available
* SEL_LVDS=H

Figure 1

4-3. Backlight

CN-A ~ D

Using connector : BHR-03VS-1 : White (JST)

: BHR-03VL-1 : Yellow (JST)

Corresponding connector : SM02(8.0)B-BHS-1R-TB (JST)

Pin no.	symbol	Function	Color of FL cable	
			CN-A/C	CN-B/D
1	V_{HIGH}	Power supply for lamp (High voltage side)	Pink	Orange
2				
3	V_{LOW}	Power supply for lamp (Low voltage side)	Blue	Gray
Color of connector			White	Yellow

5. Absolute Maximum Ratings

Parameter	Symbol	Condition	Terminal Symbol	Ratings	Unit	Remark
Supply voltage	V_{CC}	$T_a=25$	V_{CC}	-0.3 ~ +6.0	V	【Note1】
Input voltage	V_{I1}	$T_a=25$	LVDS input signal	-0.3 ~ +3.6	V	
	V_{I2}	$T_a=25$	SELLVDS	-0.3 ~ +3.6	V	
Lamp input voltage	V_{HIGH}	-	$V_{HIGH}(CN-A \sim D)$	0 ~ +3000	V _{rms}	【Note1,2】
Storage temperature	T_{STG}	Ambient	-	-25 ~ +60		【Note1】
Operating temperature	T_{OPA}	Ambient	-	0 ~ +60 (Panel surface)		【Note1】

【Note1】 Humidity : 90%RH Max. ($T_a \leq 40$)

Maximum wet-bulb temperature at 39 or less. ($T_a > 40$)

No condensation.

【Note2】 Do not keep the high voltage when the lamp does not work.

【Note3】 There is a possibility of causing deterioration in the irregularity and others of the screen and the display fineness when preserving or using it in more than 60 .

6. Electrical Characteristics

6-1. TFT-LCD panel driving

Ta = +25

Parameter		Symbol	Min.	Typ.	Max.	Unit	Remark
Supply voltage		V _{CC}	+4.75	+5.0	+5.25	V	【Note3】
Current dissipation	V _{CC} =5.0V	I _{CC}	-	750	1400	mA	【Note4】
Input voltage for LVDS	LVDS signal	V _L	0	-	2.4	V	
Permissible input ripple voltage		V _{RP}	-	-	100	mVp-p	V _{CC} =+3.3V
Differential input threshold voltage	High	V _{TH}	-	-	V _{CM} +100	mV	V _{CM} =+1.2V
	Low	V _{TL}	V _{CM} -100	-	-	mV	【Note1】
Input voltage	High	V _{IH}	2.2	-	3.3	V	【Note2】
	Low	V _{IL}	0	-	0.8	V	
Input current	High	I _{OH}	-	-	400	μA	V _{I2} =+3.3V 【Note2】
	Low	I _{OL}	-10	-	+10	μA	V _{I2} =0V 【Note2】
Terminal resistor		R _T	-	100	-		Differential input

【Note1】 V_{CM} : Common mode voltage of LVDS driver.

【Note2】 SELLVDS

【Note3】 On-off condition for supply voltage

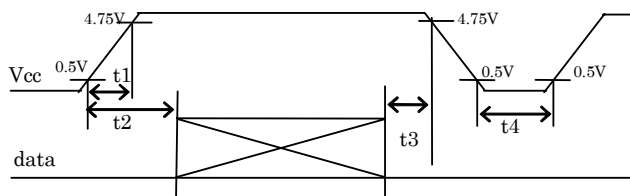

0 < t1 20ms 0 < t2 40ms
0 < t3 40ms 0.5s t4

Vcc-dip conditions

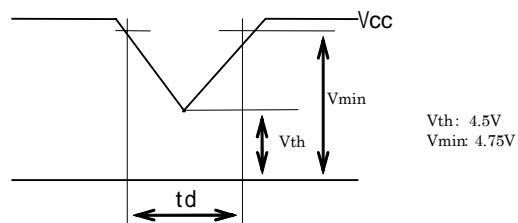

1) Vth Vcc < Vmin
td 20ms

2) Vcc < Vth

Vcc-dip conditions should also follow the on-off conditions for supply voltage.

【Note4】 Current dissipation

Standard value: 16-gray-bar pattern

(Measurement condition V_{CC}=+5.0V, f_{ck}=54MHz, Ta=25)

Refer to Chapter 8 for RGB each gray scale

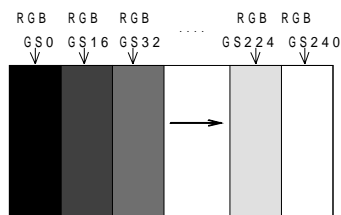

Maximum value: vertical 2dot checker (0/256-255/256)

(Measurement condition V_{CC}=+4.75V, f_{ck}=70MHz, Ta=25)

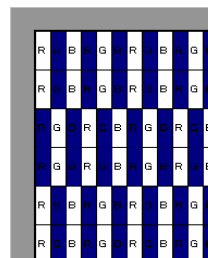

6-2. Backlight

The back light system is an edge-lighting type with 4 CCFTs (Cold Cathode Fluorescent Tube).

The characteristics of the lamp are shown in the following table.

The value mentioned below is at the case of one CCFT.

Parameter	Symbol	Min.	Typ.	Max.	Unit	Remark
Lamp current range	I_L	4.0	7.0	8.0	mArms	【Note1】
Lamp voltage	V_L	-	750	-	Vrms	$I_L=7.0\text{mArms}$ $T_a=25$
Lamp power consumption	P_L	-	5.25	-	W	【Note2】
Lamp frequency	F_L	40	50	60	kHz	【Note3】
Kick-off voltage 【Note4】	V_s	-	1500	1600	Vrms	Inverter output voltage $T_a=0$

【Note1】 Lamp current is measured by high frequency current measurement equipment connected to V_{LOW} at circuit showed below.

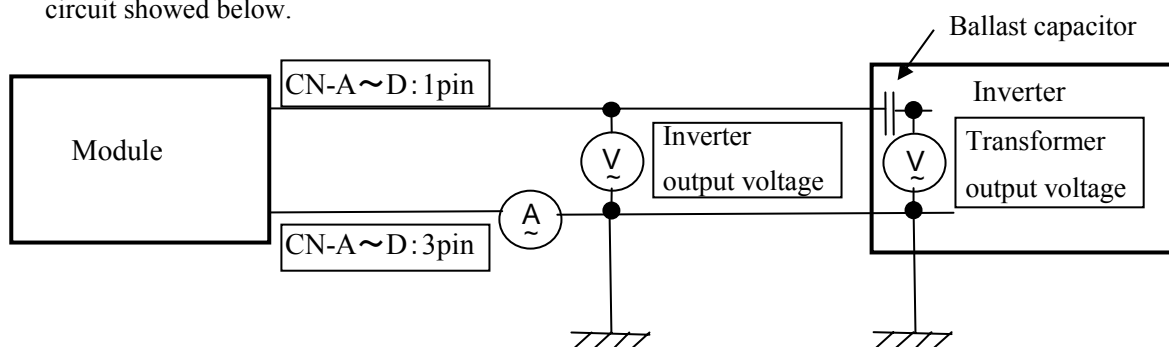

【Note2】 Referential data per one CCFT by calculation ($I_L \times V_L$).

The data don't include loss at inverter. ($I_L=7.0$ mArms)

【Note3】 Lamp frequency of inverter may produce interference with horizontal synchronous frequency, and this may cause horizontal beat on the display. Therefore, adjust lamp frequency, and keep inverter as far as from module or use electronic shielding between inverter and module to avoid interference.

【Note4】 This is transformer output voltage at 12pF for the ballast capacitor of a AS114(NF corporation). The kick-off voltage may rise up on the user set, please decide the open output voltage by checking not to occur lighting failure under operation state.

The open output voltage of the inverter shall be maintained for more than 1s; otherwise the lamp may not be turned on.

Moreover, the circuit composition shall not be decreased until both lamps light.

【Note5】 The lamp is expendable supplies. The lifetime of the lamp is 50,000 hours (reference value) in the following condition but this numerical value is not guaranteed.

Above value is applicable when lamp is placed horizontally.

Lamp life time is defined that it applied either or under this condition

(Continuous turning on at $T_a=25^\circ\text{C}$, $I_L=7.0\text{mArms}$)

Brightness becomes 50% of the original value under standard condition.

Kick-off voltage at $T_a=0^\circ\text{C}$ exceeds maximum value, (1,600)Vrms.

(Lamp life time may vary if lamp is in portrait position due to the change of mercury density inside the lamp.)

Lamp life time shortens according to the state of mounting and use.

In case of operating under lower temp environment, the lamp exhaustion is accelerated and the brightness becomes lower. (Continuous operating for around 1 month under lower temp condition may reduce the brightness to half of the original brightness.)

In case of such usage under lower temp environment, periodical lamp exchange is recommended.

【Note6】 • The performance of the backlight, for example life time or brightness, is much influenced by the characteristics of the DC-AC inverter for the lamp. When you design or order the inverter, please make sure that a poor lighting caused by the mismatch of the backlight and the inverter (miss-lighting, flicker, etc.) never occur. When you confirm it, the module should be operated in the same condition as it is installed in your instrument.

Be sure to use a back light power supply with the safety protection circuit such as the detection circuit for the excess voltage, excess current and or electric discharge waveform.

Be sure to use the detect circuit by which one side of the CCFT lamps can be controlled independently.

Otherwise, when one side of the CCFT is open, the excess current may possibly be applied to the other side of the lamp.

- It is required to have the inverter designed so that to allow the impedance deviation of the four CCFT lamps and the capacity deviation of ballast capacitor.
- Under the environment of 10 lx or less, lamp may not turn on or it may take some time to turn on.

7. Timing characteristics of input signals

7-1. Timing characteristics

	Parameter	Symbol	Min.	Typ.	Max.	Unit	Remark
Clock signal	Frequency	1/Tc	40	54	70	MHz	
ENAB signal	Horizontal period	TH	670	844	929	clock	【Note2】
			12.3	15.6	-	μs	
	Horizontal period (High)	THd	640	640	640	clock	
	Vertical period	TV	1031	1066	2043	line	【Note1】
			13.1	16.7	20.5	ms	【Note2】
	Vertical period (High)	TVd	1024	1024	1024	line	

【Note1】 In case of using the long vertical period, the deterioration of display quality, flicker etc. may occur.

【Note2】 The horizontal display position is determined by ENAB signal and the input data corresponding to the rising edge of DCLK is displayed at the left end of the active area.

Regarding the vertical display position, the data starting from following ENAB rising is displayed at the top of the active area in case of no rising ENAB more than 2003clk from ENAB rising.

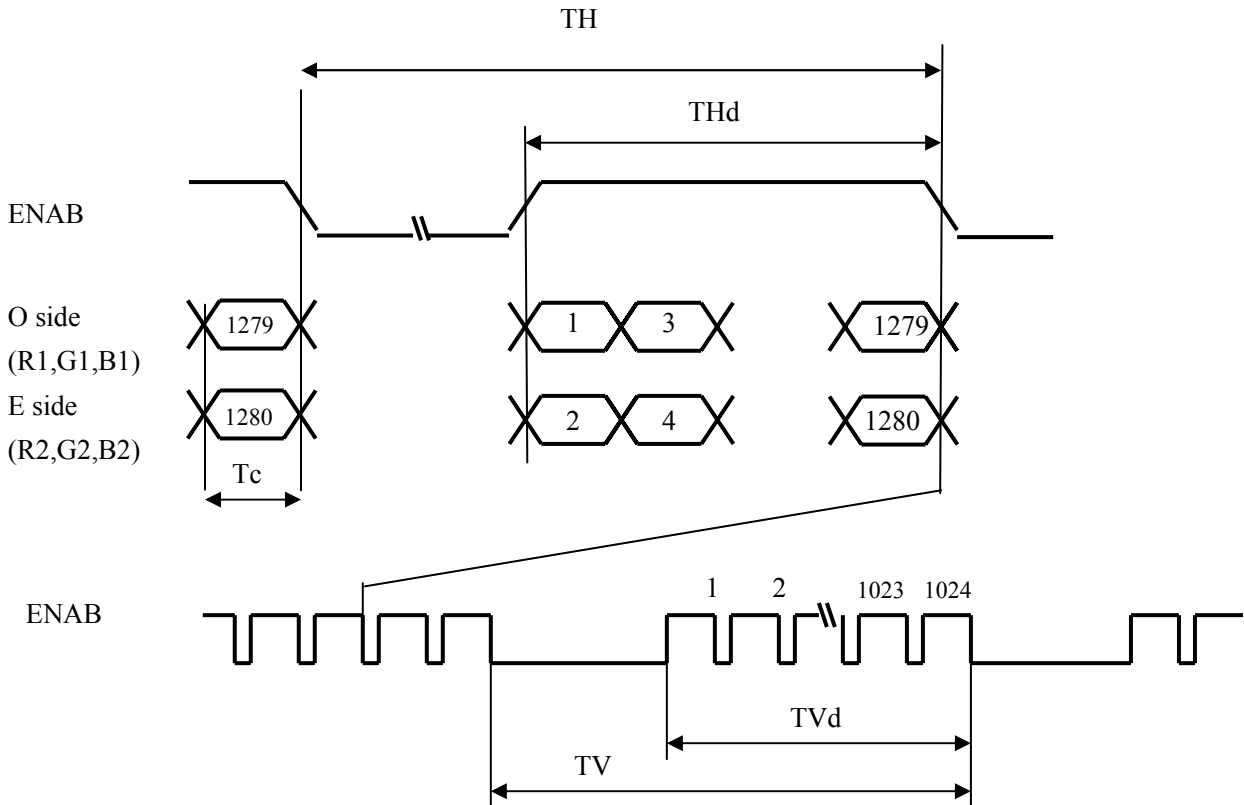

7-2. Input Data Signals and Display Position on the screen

Display position of input data (H, V)

Two pixels data is sampled at the same time.

DO (odd 1 data): RO0 ~ RO7, GO0 ~ GO7, BO0 ~ BO7

DE (even 1 data): RE0 ~ RE7, GE0 ~ GE7, BE0 ~ BE7

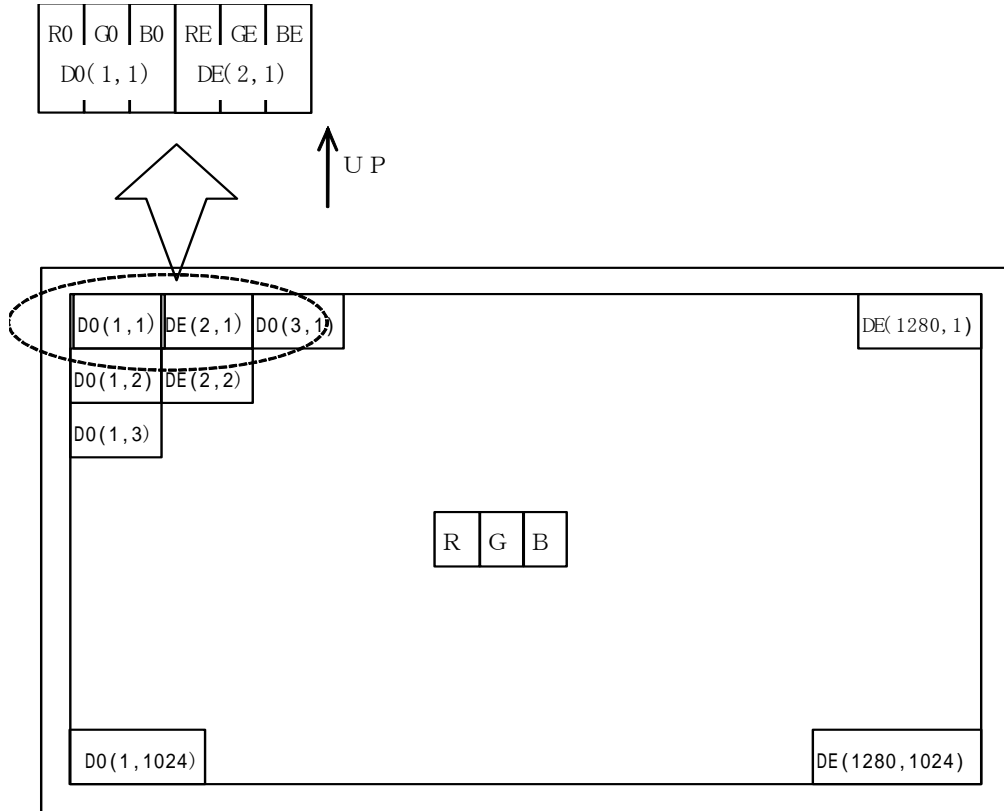

8. Input Signals, Basic Display Colors and Gray Scale of Each Color

8-1. 8bit input

	Colors & Gray scale	Data signal																											
		Gray Scale	R0	R1	R2	R3	R4	R5	R6	R7	G0	G1	G2	G3	G4	G5	G6	G7	B0	B1	B2	B3	B4	B5	B6	B7			
Basic Color	Black	-	0	0	0	0	0	0	0	0	0	0	0	0	0	0	0	0	0	0	0	0	0	0	0	0	0		
	Blue	-	0	0	0	0	0	0	0	0	0	0	0	0	0	0	0	0	1	1	1	1	1	1	1	1	1		
	Green	-	0	0	0	0	0	0	0	0	1	1	1	1	1	1	1	1	0	0	0	0	0	0	0	0	0		
	Cyan	-	0	0	0	0	0	0	0	0	1	1	1	1	1	1	1	1	1	1	1	1	1	1	1	1	1		
	Red	-	1	1	1	1	1	1	1	1	0	0	0	0	0	0	0	0	0	0	0	0	0	0	0	0	0		
	Magenta	-	1	1	1	1	1	1	1	1	0	0	0	0	0	0	0	0	1	1	1	1	1	1	1	1	1		
	Yellow	-	1	1	1	1	1	1	1	1	1	1	1	1	1	1	1	1	0	0	0	0	0	0	0	0	0		
	White	-	1	1	1	1	1	1	1	1	1	1	1	1	1	1	1	1	1	1	1	1	1	1	1	1	1		
Gray Scale of Red	Black	0	0	0	0	0	0	0	0	0	0	0	0	0	0	0	0	0	0	0	0	0	0	0	0	0	0		
	↑	1	1	0	0	0	0	0	0	0	0	0	0	0	0	0	0	0	0	0	0	0	0	0	0	0	0		
	Darker	2	0	1	0	0	0	0	0	0	0	0	0	0	0	0	0	0	0	0	0	0	0	0	0	0	0		
	↑	↓																											
	↓	↓																											
	Brighter	253	1	0	1	1	1	1	1	1	0	0	0	0	0	0	0	0	0	0	0	0	0	0	0	0	0		
	↓	254	0	1	1	1	1	1	1	1	0	0	0	0	0	0	0	0	0	0	0	0	0	0	0	0	0		
	Red	255	1	1	1	1	1	1	1	1	0	0	0	0	0	0	0	0	0	0	0	0	0	0	0	0	0		
Gray Scale of Green	Black	0	0	0	0	0	0	0	0	0	0	0	0	0	0	0	0	0	0	0	0	0	0	0	0	0	0		
	↑	1	0	0	0	0	0	0	0	0	1	0	0	0	0	0	0	0	0	0	0	0	0	0	0	0	0		
	Darker	2	0	0	0	0	0	0	0	0	0	1	0	0	0	0	0	0	0	0	0	0	0	0	0	0	0		
	↑	↓																											
	↓	↓																											
	Brighter	253	0	0	0	0	0	0	0	0	1	0	1	1	1	1	1	1	0	0	0	0	0	0	0	0	0		
	↓	254	0	0	0	0	0	0	0	0	0	1	1	1	1	1	1	1	0	0	0	0	0	0	0	0	0		
	Green	255	0	0	0	0	0	0	0	0	1	1	1	1	1	1	1	1	0	0	0	0	0	0	0	0	0		
Gray Scale of Blue	Black	0	0	0	0	0	0	0	0	0	0	0	0	0	0	0	0	0	0	0	0	0	0	0	0	0	0		
	↑	1	0	0	0	0	0	0	0	0	0	0	0	0	0	0	0	0	1	0	0	0	0	0	0	0	0		
	Darker	2	0	0	0	0	0	0	0	0	0	0	0	0	0	0	0	0	0	1	0	0	0	0	0	0	0		
	↑	↓																											
	↓	↓																											
	Brighter	253	0	0	0	0	0	0	0	0	0	0	0	0	0	0	0	0	1	0	1	1	1	1	1	1	1		
	↓	254	0	0	0	0	0	0	0	0	0	0	0	0	0	0	0	0	0	1	1	1	1	1	1	1	1		
	Blue	255	0	0	0	0	0	0	0	0	0	0	0	0	0	0	0	0	1	1	1	1	1	1	1	1	1		

0 : Low level voltage, 1 : High level voltage.

Each basic color can be displayed in 256 gray scales of red, 256 gray scales of green, and 256 gray scales of blue from 8 bit data signals. According to the combination of total 24 bit data signals, 16,777,216 color display can be achieved on the screen.

9. Optical Characteristics

Ta=25 , Vcc =+3.3V

Parameter		Symbol	Condition	Min.	Typ.	Max.	Unit	Remark
Viewing angle range	Horizontal	21, 22	CR > 10	85	-	-	Deg.	
	Vertical	11, 12		85	-	-	Deg.	
	All direction			-	80	-	Deg.	
Contrast ratio		CRn	Optimum viewing angle	400	900	-		【Note2,4】
Response Time (Black White Black)		r+ d	=0 °	-	12	-	ms	【Note3(Condition2),4,5】
Chromaticity of White		x		0.283	0.313	0.343		【Note4】
		y		0.299	0.329	0.359		
Chromaticity of Red		x		0.610	0.640	0.670		
		y		0.319	0.349	0.379		
Chromaticity of Green		x		0.253	0.283	0.313		
		y		0.568	0.598	0.628		
Chromaticity of Blue		x		0.112	0.142	0.172		
		y		0.041	0.071	0.101		
Luminance of white		YLI		210	300	-	cd/m ²	
White Uniformity		w	-	-	1.43		【Note5】	

The measurement shall be executed 30 minutes after lighting at rating.(IL=7.0mArms)

The optical characteristics shall be measured in a dark room or equivalent state with the method shown in Fig.2 below.

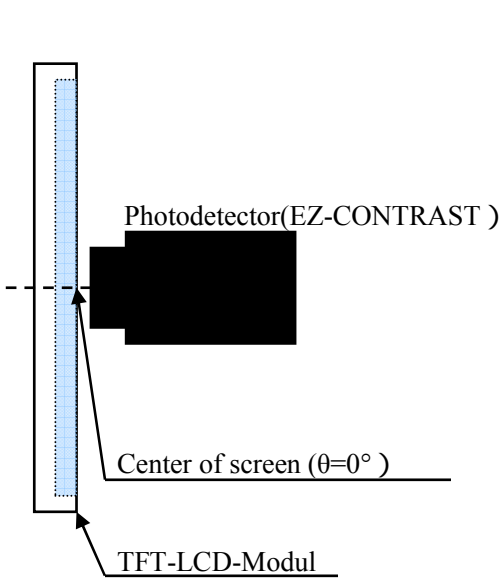

Fig2-1 Viewing angle measurement method

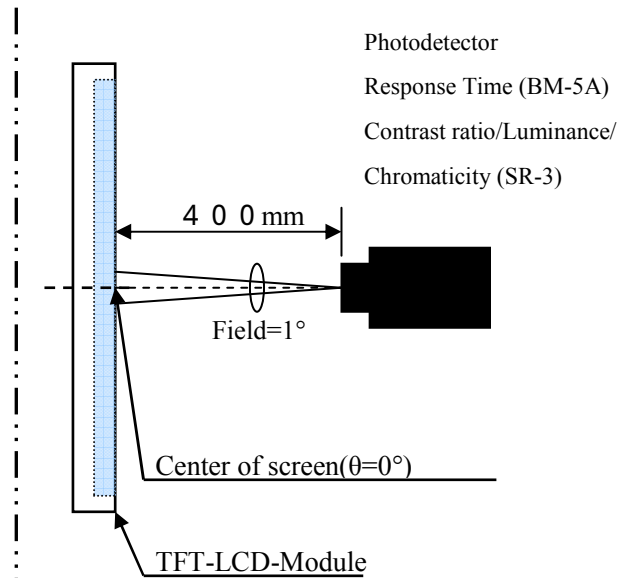
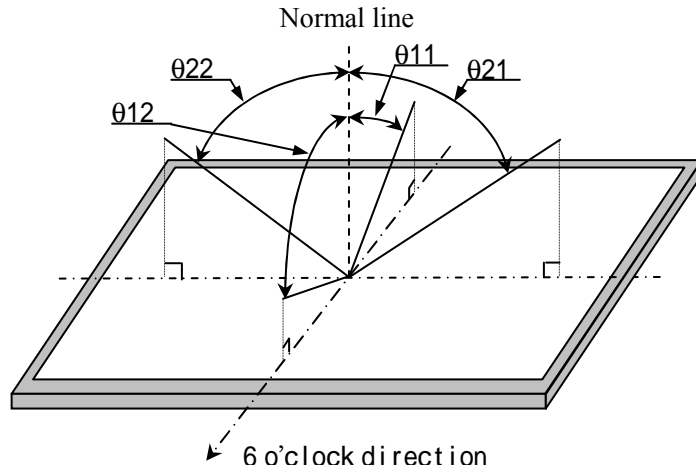

Fig2-2 Luminance/Contrast ratio/Response time/Chromaticity measurement method

Fig2 Optical characteristics measurement method

【Note1】 Definitions of viewing angle range:



【Note2】 Definition of contrast ratio:

The contrast ratio is defined as the following.

$$\text{Contrast Ratio (CR)} = \frac{\text{Luminance (brightness) with all pixels white}}{\text{Luminance (brightness) with all pixels black}}$$

【Note3】 Definition of response time:

The response time is defined as the following figure and shall be measured by switching the input signal for "black" and "white".

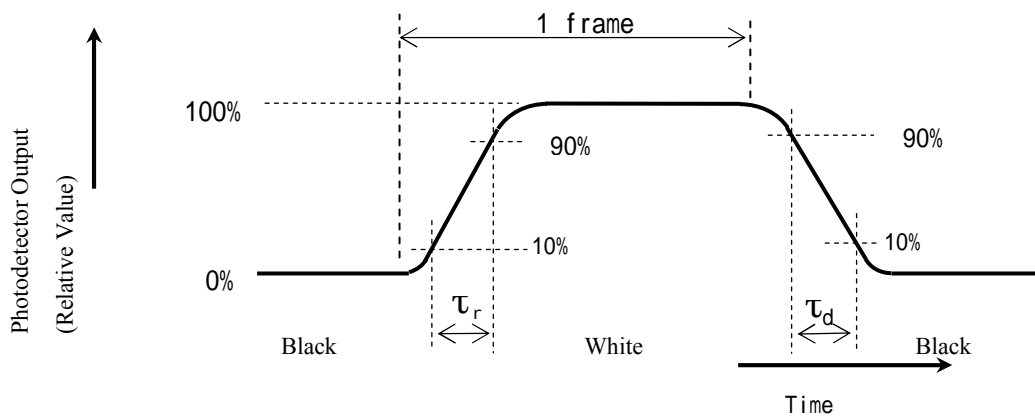

【Note4】 This shall be measured at center of the screen.

【Note5】 Definition of white uniformity:

White uniformity is defined as the following with nine measurements (①~⑨).

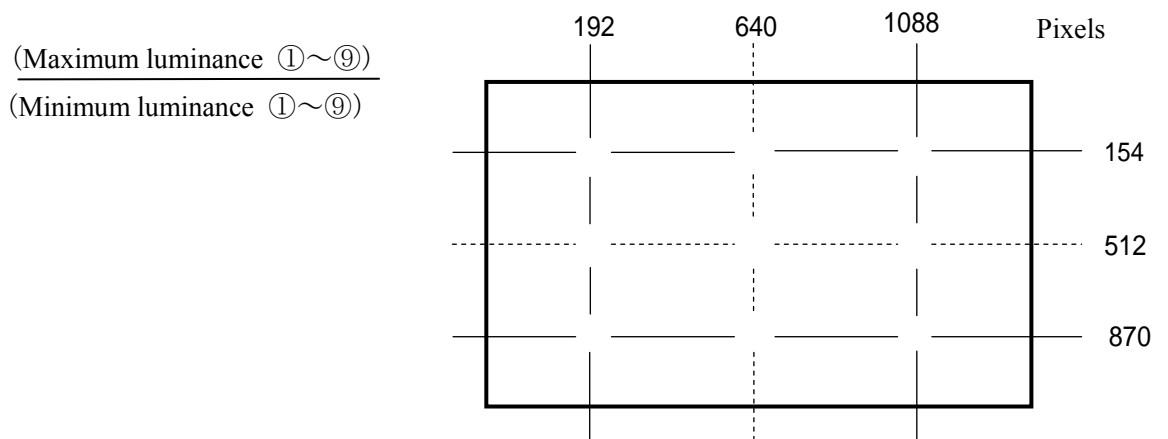

10. Display dignity

The item concerning externals and the display dignity is decided by the shipment inspection standard book..

11. Handling Precautions

- a) Be sure to turn off the power supply when inserting or disconnecting the cable.
- b) Be sure to design the cabinet so that the module can be installed without any extra stress such as warp or twist.
- c) Since the front polarizer is easily damaged, pay attention not to scratch it.
Blow away dust on the polarizer with antistatic N₂ blow. It is undesirable to wipe off because a polarizer is sensitive.
It is recommended to peel off softly using the adhesive tape when soil or finger oil is stuck to the polarizer.
When unavoidable, wipe off carefully with a cloth for wiping lenses.
- d) Wipe off water drop immediately. Long contact with water may cause discoloration or spots.
- e) When the panel surface is soiled, wipe it with absorbent cotton or other soft cloth.
- f) Since the panel is made of glass, it may break or crack if dropped or bumped on hard surface.
Handle with care.
- g) Since CMOS LSI is used in this module, take care of static electricity and set the human earth when handling. Observe all other precautionary requirements in handling components.
- h) Since there is a circuit board in the module back, stress is not added at the time of a design assembly.
If stress is added, there is a possibility that circuit parts may be damaged.
- i) Protection film is attached to the module surface to prevent it from being scratched .
Peel the film off slowly, just before the use, with strict attention to electrostatic charges.
Blow off 'dust' on the polarizer by using ionized nitrogen.
- j) The polarizer surface on the panel is treated with Anti-Glare for low reflection. In case of attaching protective board over the LCD, be careful about the optical interface fringe etc. which degrades display quality.
- k) Do not expose the LCD panel to direct sunlight.
Lightproof shade etc. should be attached when LCD panel is used under such environment.
If a light strong against a LCD panel is irradiated, it may lead to degradation of the panel characteristic and display grace may get worse.
- l) Connect GND to 4 place of mounting holes to stabilize against EMI and external noise.
- m) There are high voltage portions on the backlight and very dangerous. Careless touch may lead to electrical shock.
When exchange lamps or service, turn off the power without fail.
- n) When handling LCD modules and assembling them into cabinets, please be noted that long-term storage in the environment of oxidization or deoxidization gas, and the use of such materials as reagent, solvent, adhesive, resin, etc. which generate these gasses, may cause corrosion, discoloration, degradation of display grace, and abnormalities of operation.
- o) Please consider dewy consideration prevention when using it in high temperature and high humidity environment.
- p) Cold cathode fluorescent lamp in LCD panel contains a small amount of mercury, please follow local ordinances or regulations for disposal.
- q) Be careful of a back light lead not to pull by force at the time of the wiring to an inverter, or line processing.
- r) When install LCD modules in the cabinet, please tighten with "torque = max 0.343 N•m (max 3.5kgf•cm).
Be sure to confirm it in the same condition as it is installed in your instrument.
- s) Liquid crystal contained in the panel may leak if the LCD is broken. Rinse it as soon as possible if it gets inside your eye or mouth by mistake.
- t) Notice : Never dismantle the module , because it will cause failure.
Moreover, please do not peel off and do not cut the tapes pasted to the product.
However, the tape fixed panel protection film is excluded.
- u) Be careful when using it for long time with fixed pattern display as it may cause afterimage.
(Please use a screen saver etc., in order to avoid an afterimage.)
- v) Adjusting volume has been set optimally before shipment, so do not change any adjusted value.
If adjusted value is changed, the specification may not be satisfied.
- w) If a minute particle enters in the module and adheres to an optical material, it may cause display non-uniformity issue, etc. Therefore, fine-pitch filters have to be installed to cooling and inhalation hole if you intend to install a fan.

x)The lamp used for this product is very sensitive to the temperature.

Luminance decreases rapidly when it is used for a long time or repeatedly under the environment of the low temperature or the module is being cooled.

Please avoid the continuous or repeating use of it under such an environment.

It may decrease up to 50% of the initial luminance in about one month under the low temperature environment.

Please consult our company when it is used under the environment like the above mentioned.

12. Packing form

Product countries / Areas	JAPAN, CHINA
Piling number of cartons	5 (MAX)
Packing quantity in one carton	5pcs
Carton size [mm]	493(W) × 293(D) × 417(H)
Total mass of one carton filled with full modules	15kg
Packing form is shown	Page 21

13 . Reliability test items

No	Test item	Conditions	
1	High temperature storage test	Ta = 60 240h	
2	Low temperature storage test	Ta = -25 240h	
3	High temperature & high humidity operation test	Ta = 40 ; 90%RH 240h (No condensation)	
4	High temperature operation test	Ta = 60 240h (Panel surface)	
5	Low temperature operation test	Ta = 0 240h	
6	Vibration test	Waveform : Sine wave Frequency : 10 ~ 57Hz/Vibration width (one side) : 0.15mm : 58 ~ 500Hz/Gravity : 19.6m/s ² Sweep time : 11minutes Test period : 3 hours (1 hour for each direction of X,Y,Z)	【Note】
7	Shock test	Max. gravity : 490m/s ² Pulse width : 11ms, sine half-wave Direction : ± X, ± Y, ± Z, once for each direction.	
8	Electrostatic discharge test (non- operating)	Contact discharge (150pF 330): non-operation= ± 10kV, operation= ± 8kV Aerial discharge (150pF 330): non-operation= ± 20kV, operation= ± 15kV	

【Note】

A gap of panel shall not occur by vibration or the shock.

【Result Evaluation Criteria】

Under the display quality test conditions with normal operation state, these shall be no change which may affect practical display function.

14. Others

14-1. Lot No. Label

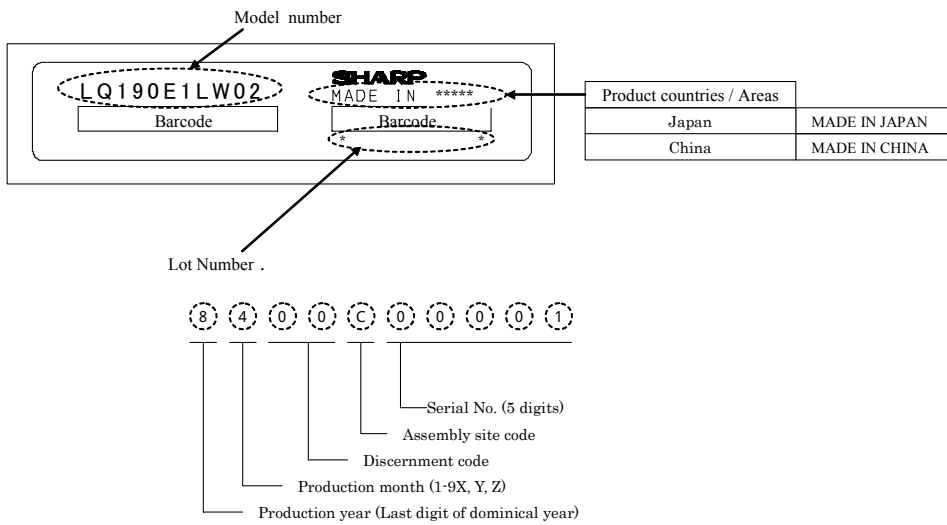

14-2. Packing box Label

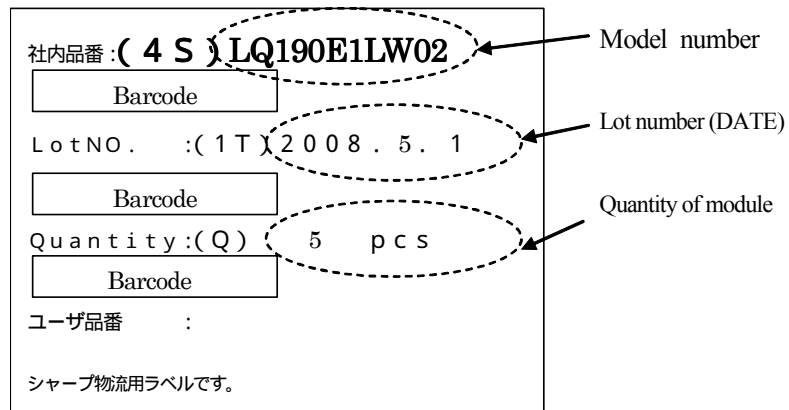

14-3. The chemical ozone depleting substance is not used.

14-4. Fluorescent lamp in LCD panel contains a small amount of mercury, please follow local ordinances or regulations for disposal. (It marks on the back of the module.)

FLUORESCENT LAMPS IN THIS PRODUCT CONTAIN MERCURY AND MUST BE DISPOSED OF ACCORDING TO LOCAL ORDINANCE, STATE OR FEDERAL LAWS.
 この製品の内部の蛍光管には水銀が含まれていますので、地方自治体の条例・州法または連邦法に従って廃棄してください。

14-5. If any problem occurs in relation to the description of this specification, it shall be resolved through discussion with spirit of cooperation.

The figure left below (cardboard box recycling symbol mark) is written to the packing box..

And, the figure right below is written to the packing box of the settlement for the RoHS restriction.

R.C. (RoHS Compliance) means it suits the RoHS directive.

This LCD module is compliant with RoHS Directive.



Cardboard box •

Recycling symbol mark

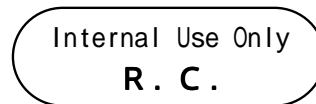

Mark for RoHS directive

14-6. Recommended inverter

An optical specification of this module uses the following inverters.

Model : L Q 0 D Z C 5 0 1 6

Minimum order quantity : 1 0 p c s

14-7. Lamp for exchange A S S Y

Lamp ASSY for the exchange that suits this LCD unit supplies for value by an upper and lower set as a material for maintenance.

Model : L Q 0 D D B 0 0 8 6 :upper and lower set

Minimum order quantity : 2 0 p c s

15 . Range of storage temperature and humidity environmental condition

Temperature 0 ~ 40

Relative humidity 90% and below

(Note) • Please manage as average value of the storage temperature and humidity environment referring to the following condition.

Summer 20 ~ 35 85% and below, Winter 5 ~ 15 85% and below

- Please manage within 240 hours in total at the time kept under the environment of 40 90%RH.

Direct sunlight

Please keep it in the state of wrapping or the darkroom so that direct sunshine should not strike directly into the product.

Ambient atmosphere

Please do not keep it in the place with the danger of the generation of the causticity gas and the volatile solvent.

Dewy condensation prevention

- Please do not put the wrapping box directly on the floor, and keep it on palette or rack to avoid dewy condensation.

Moreover, please put it in a constant direction correctly to improve ventilation under the palette.

- Please separate from the wall in the storage warehouse and keep it.
- Please pay attention that ventilation is improved, and set up the ventilator etc. in the warehouse.
- Please manage so that there is no rapid temperature change more than natural environment.

Storage period

Please keep within one year under the above-mentioned storage condition.

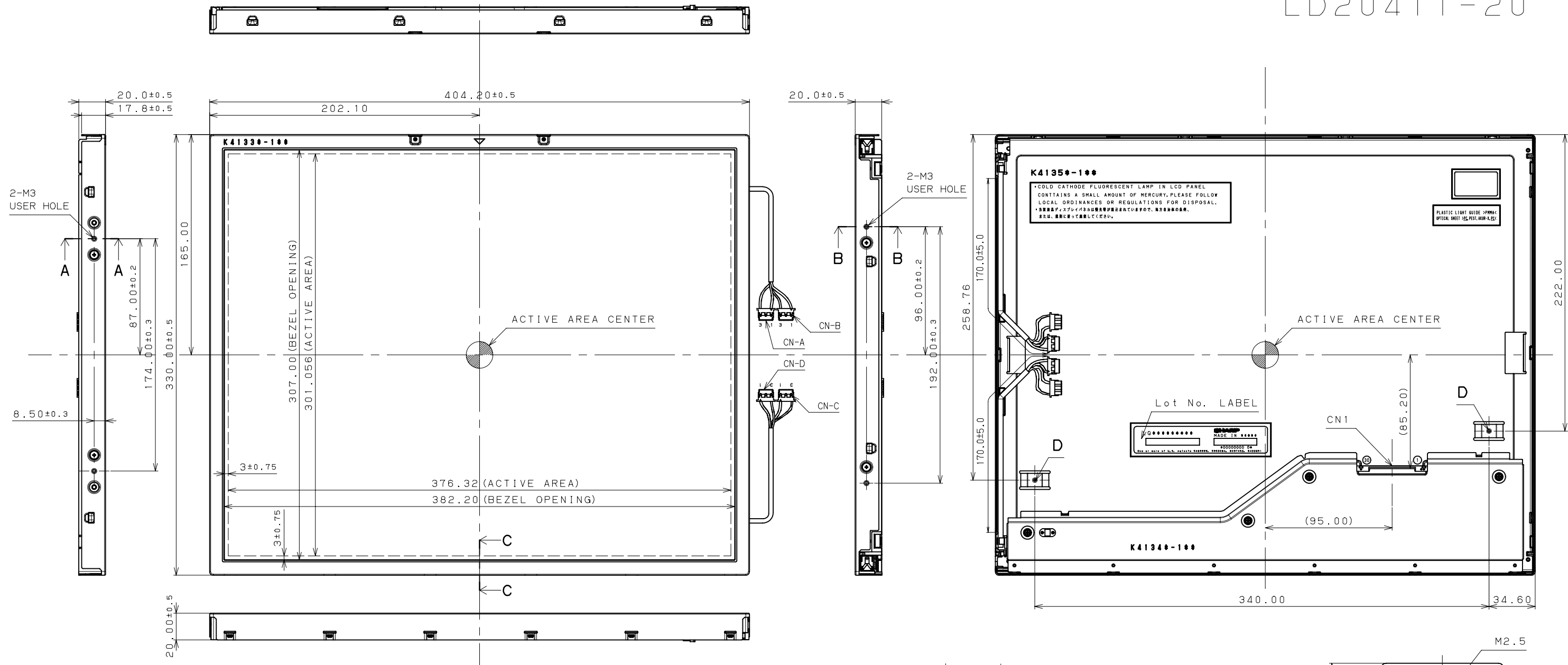

I/F connector: CN1
Pin assignment

PIN 1	PIN 2	PIN 3	PIN 4	PIN 5	PIN 6	PIN 7	PIN 8	PIN 9	PIN 10
Rx00-	Rx00+	Rx01-	Rx01+	Rx02-	Rx02+	GND	Rx0C-	Rx0C+	Rx03-
PIN 11	PIN 12	PIN 13	PIN 14	PIN 15	PIN 16	PIN 17	PIN 18	PIN 19	PIN 20
Rx03+	RxE0-	RxE0+	GND	RxE1-	RxE1+	GND	RxE2-	RxE2+	RxEC-
PIN 21	PIN 22	PIN 23	PIN 24	PIN 25	PIN 26	PIN 27	PIN 28	PIN 29	PIN 30
RxEC+	RxE3-	RxE3+	GND	SEL LVDS	N.C.	N.C.	Vcc	Vcc	Vcc

Corresponding connectors: FI-X30M, FI-X30H, FI-X30HL, FI-X30C, FI-X30C2L (Japan Aviation Electronics Industry, LTD.)

NOTES

1. UNSPECIFIED TOLERANCE TO BE ±0.5

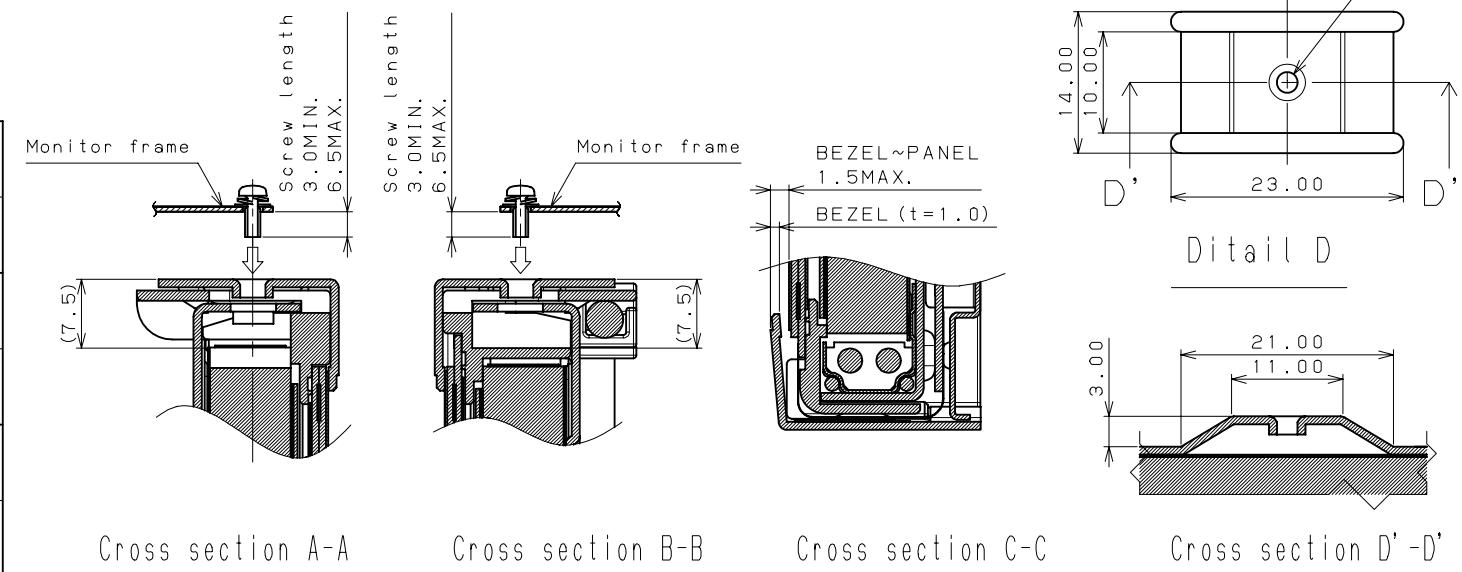

Fig.1: Outline dimensions (LQ190E1LW02)

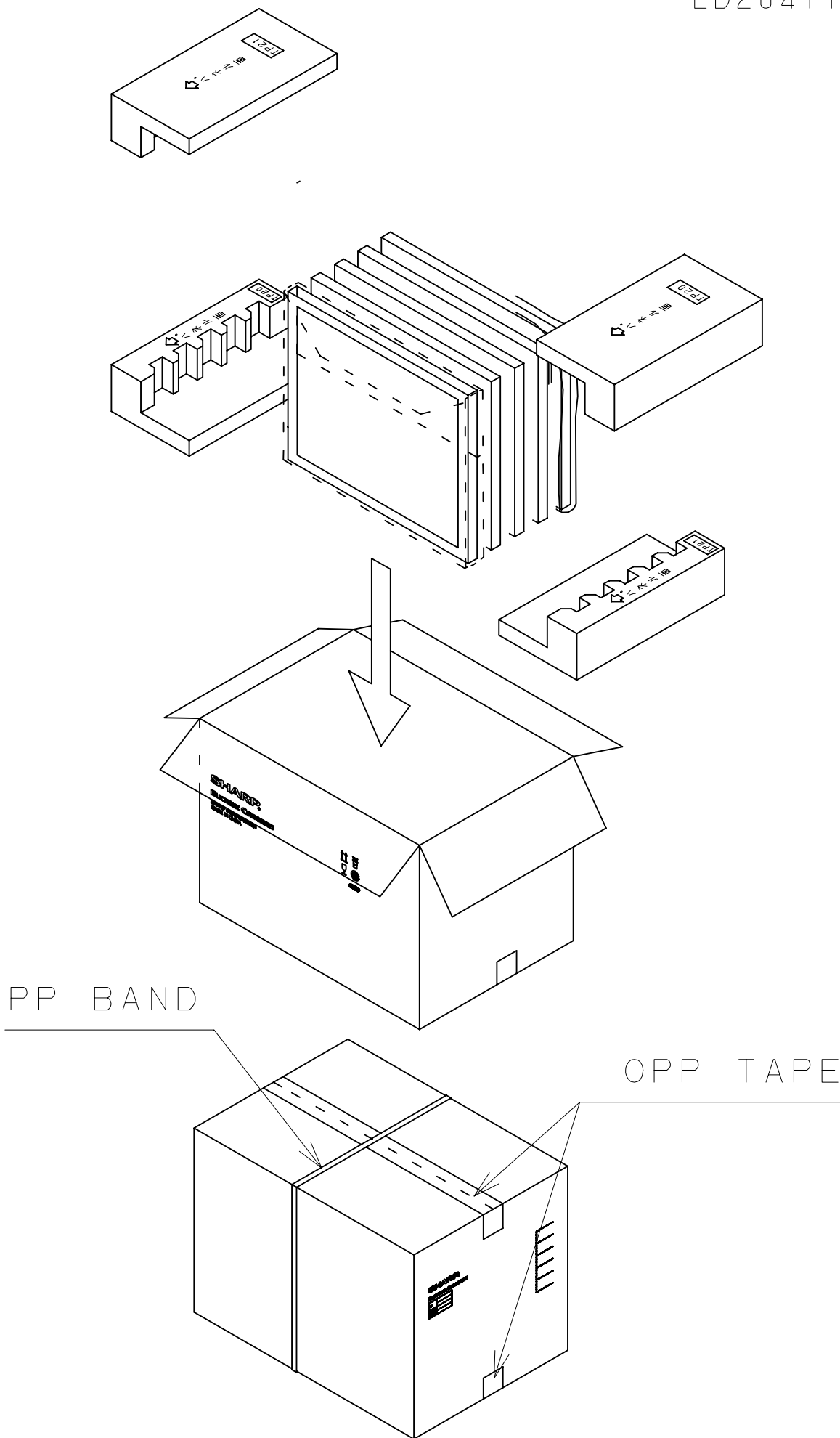

Fig.2:Packing Form (LQ190E1LW02)