

SHARP

No.	LD - 16950
DATE	Sep. 1. 2004

TECHNICAL LITERATURE
FOR
TFT - LCD module

MODEL No. LQ150X1LGB1

The technical literature is subject to change without notice.
So, please contact Sharp or its representative before designing
your product based on this literature.

DEVELOPMENT ENGINEERING DEPARTMENT 2
TAKI DEVELOPMENT CENTER
AVC LIQUID CRYSTAL DISPLAY GROUP
SHARP CORPORATION

1. Application

This specification applies to the color 15.0 XGA TFT-LCD module LQ150X1LGB1.

This technical literature are the proprietary product of SHARP CORPORATION("SHARP) and include materials protected under copyright of SHARP. Do not reproduce or cause any third party to reproduce them in any form or by any means, electronic or mechanical, for any purpose, in whole or in part, without the express written permission of SHARP.

The device listed in this technical literature was designed and manufactured for use in OA equipment.

In case of using the device for applications such as control and safety equipment for transportation(aircraft, trains, automobiles, etc.), rescue and security equipment and various safety related equipment which require higher reliability and safety, take into consideration that appropriate measures such as fail-safe functions and redundant system design should be taken.

Do not use the device for equipment that requires an extreme level of reliability, such as aerospace applications, telecommunication equipment(trunk lines), nuclear power control equipment and medical or other equipment for life support.

SHARP assumes no responsibility for any damage resulting from the use of the device which does not comply with the instructions and the precautions specified in these technical literature sheets.

Contact and consult with a SHARP sales representative for any questions about this device.

2. Overview

This module is a color active matrix LCD module incorporating amorphous silicon TFT (Thin Film Transistor). It is composed of a color TFT-LCD panel, driver ICs, control circuit, power supply circuit and a back light unit. Graphics and texts can be displayed on a 1024 × RGB × 768 dots panel with about 16 million colors by using LVDS (Low Voltage Differential Signaling) and supplying +3.3V DC supply voltages for TFT-LCD panel driving and supply voltage for backlight.

Backlight-driving DC/AC inverter is not built in this module.

3. Mechanical Specifications

Parameter	Specifications	Unit
Display size	38 (Diagonal)	cm
	15.0 (Diagonal)	Inch
Active area	304.1 (H) × 228.1 (V)	mm
Pixel format	1024 (H) × 768 (V)	Pixel
	(1 pixel = R+G+B dots)	
Pixel pitch	0.297 (H) × 0.297 (V)	mm
Pixel configuration	R, G, B vertical stripe	
Display mode	Normally white	
Unit outline dimensions *1	331.6(W) × 254.76(H) × 12.5(D)	mm
Mass	(1300.MAX)	g
Surface treatment	Anti-glare and hard-coating : 2H	

*1.Note: excluding back light cables.

The thickness of module (D) doesn't contain the projection.

Outline dimensions are shown in Fig.1.

4. Input Terminals

4-1. TFT-LCD panel driving

CN1 (Interface signals and +3.3V DC power supply)

Using connectors : DF14H-20P-1.25H (Hirose Electric Co., Ltd.)

Corresponding connectors : DF14-20S-1.25C(Connector)
DF14-2628SCFA(Terminal)

Using LVDS Receiver : Contained in a control IC. [THC63LVDF84A(Thine) compatible]

Corresponding LVDS Transmitter : THC63LVDM83R(Thine) or compatible

Pin No.	Symbol	Function	Remark
1	Vcc	+3.3V Power supply	
2	Vcc	+3.3V Power supply	
3	GND	Ground	
4	GND	Ground	
5	RxIN0-	LVDS CH0 data signal (-)	LVDS
6	RxIN0+	LVDS CH0 data signal (+)	LVDS
7	GND	Ground	
8	RxIN1-	LVDS CH1 data signal (-)	LVDS
9	RxIN1+	LVDS CH1 data signal (+)	LVDS
10	GND	Ground	
11	RxIN2-	LVDS CH2 data signal (-)	LVDS
12	RxIN2+	LVDS CH2 data signal (+)	LVDS
13	GND	Ground	
14	RxCLKIN-	LVDS CK- data signal (-)	LVDS
15	RxCLKIN+	LVDS CK+ data signal (+)	LVDS
16	GND	Ground	
17	RxIN3-	LVDS CH3 data signal (-)	LVDS
18	RxIN3+	LVDS CH3 data signal (+)	LVDS
19	GND	Ground	
20	LVDS_SET	LVDS_SET	【Note1】

4-2 Data Mapping

1) 8 bit input

【Note1】 pin assignment with LVDS_SET pin (Thine:THC63LVDM83R)

Transmitter		20pin LVDS_SET	
Pin No	Data	=L (GND) or Open	=H (3.3V)
51	TA0	R0 (LSB)	R2
52	TA1	R1	R3
54	TA2	R2	R4
55	TA3	R3	R5
56	TA4	R4	R6
3	TA5	R5	R7 (MSB)
4	TA6	G0 (LSB)	G2
6	TB0	G1	G3
7	TB1	G2	G4
11	TB2	G3	G5
12	TB3	G4	G6
14	TB4	G5	G7 (MSB)
15	TB5	B0 (LSB)	B2
19	TB6	B1	B3
20	TC0	B2	B4
22	TC1	B3	B5
23	TC2	B4	B6
24	TC3	B5	B7 (MSB)
27	TC4	(NA)	(NA)
28	TC5	(NA)	(NA)
30	TC6	DE	DE
50	TD0	R6	R0 (LSB)
2	TD1	R7 (MSB)	R1
8	TD2	G6	G0 (LSB)
10	TD3	G7 (MSB)	G1
16	TD4	B6	B0 (LSB)
18	TD5	B7 (MSB)	B1
25	TD6	(NA)	(NA)

<LVDS_SET=L or Open>

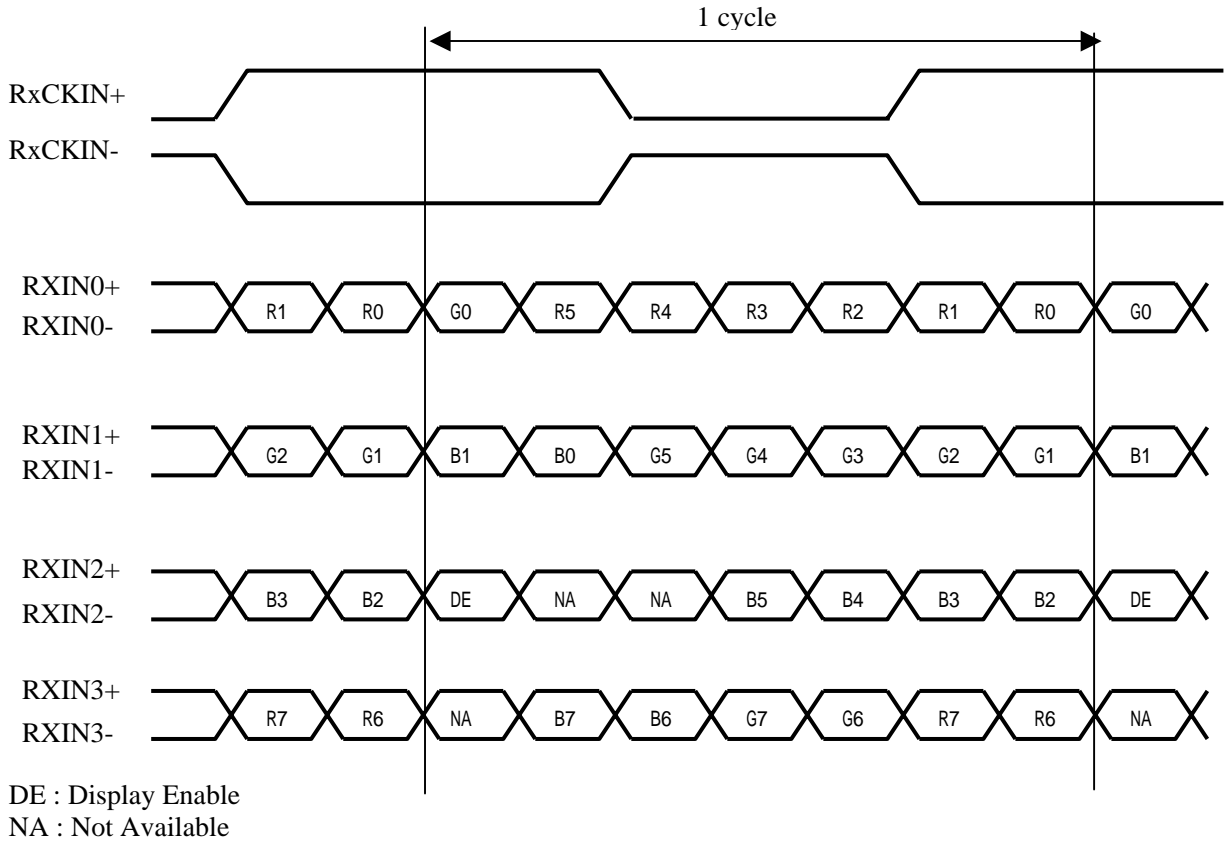

<LVDS_SET =H>

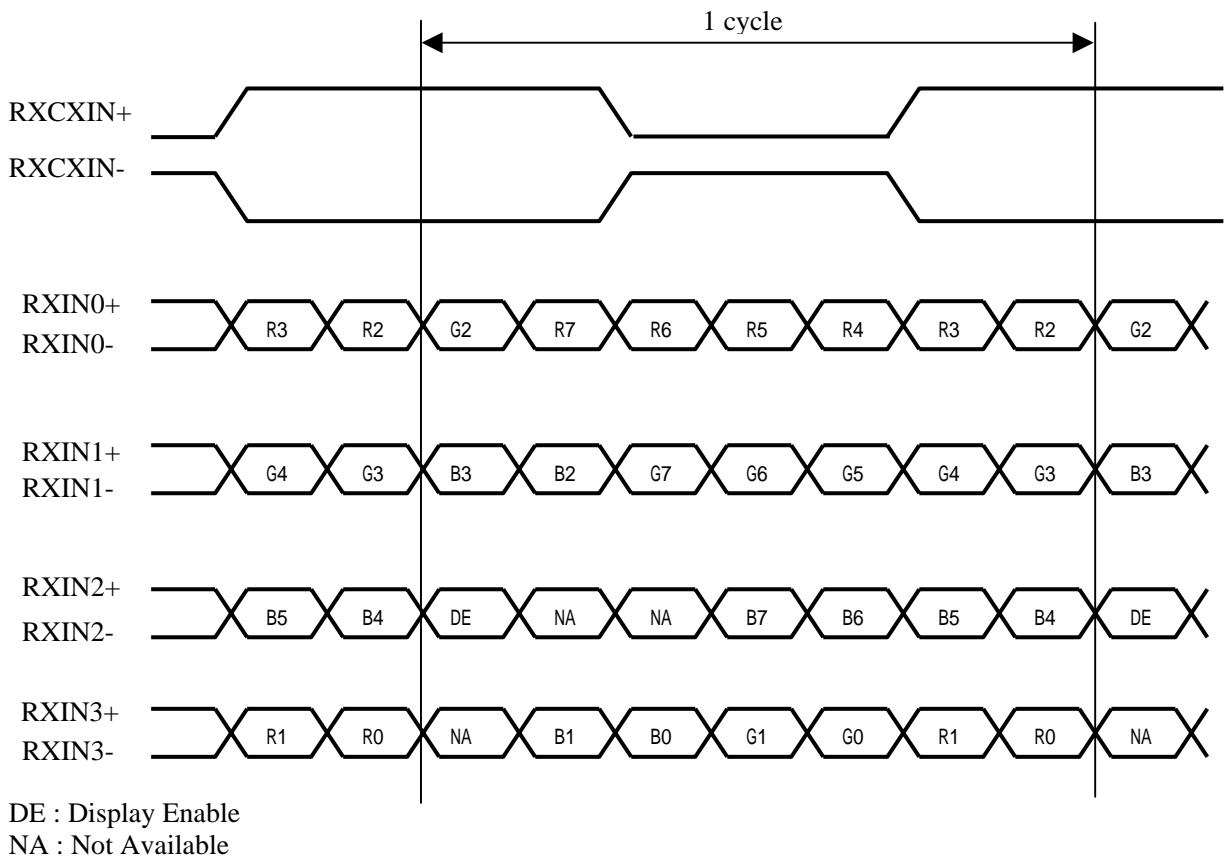

2) 6 bit input

【Note1】 pin assignment with LVDS_SET pin (Thine:THC63LVDM83R)

Transmitter		20pin LVDS_SET	
Pin No	Data	=L (GND) or Open	=H (3.3V)
51	TA0	-	R0 (LSB)
52	TA1	-	R1
54	TA2	-	R2
55	TA3	-	R3
56	TA4	-	R4
3	TA5	-	R5 (MSB)
4	TA6	-	G0 (LSB)
6	TB0	-	G1
7	TB1	-	G2
11	TB2	-	G3
12	TB3	-	G4
14	TB4	-	G5 (MSB)
15	TB5	-	B0 (LSB)
19	TB6	-	B1
20	TC0	-	B2
22	TC1	-	B3
23	TC2	-	B4
24	TC3	-	B5 (MSB)
27	TC4	-	(NA)
28	TC5	-	(NA)
30	TC6	-	DE
50	TD0	-	GND
2	TD1	-	GND
8	TD2	-	GND
10	TD3	-	GND
16	TD4	-	GND
18	TD5	-	GND
25	TD6	-	(NA)

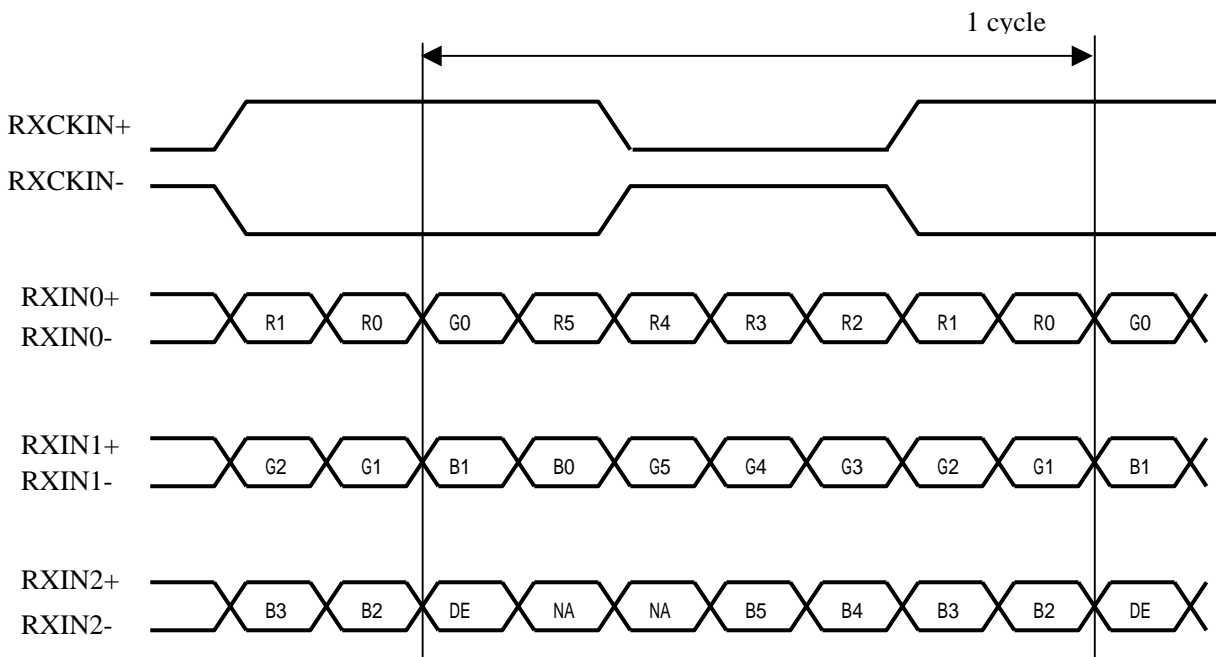

DE : Display Enable

NA : Not Available

In case of supplying 6 bit signal, it is recommended to connect pin No.17(RXIN3-) with H(3.3V), and No.18(RXIN3+) with L(GND).

(Computer Side)

(TFT-LCD side)

8Bit Mode
LVDS_SET=L (20 pin=GND or OPEN)

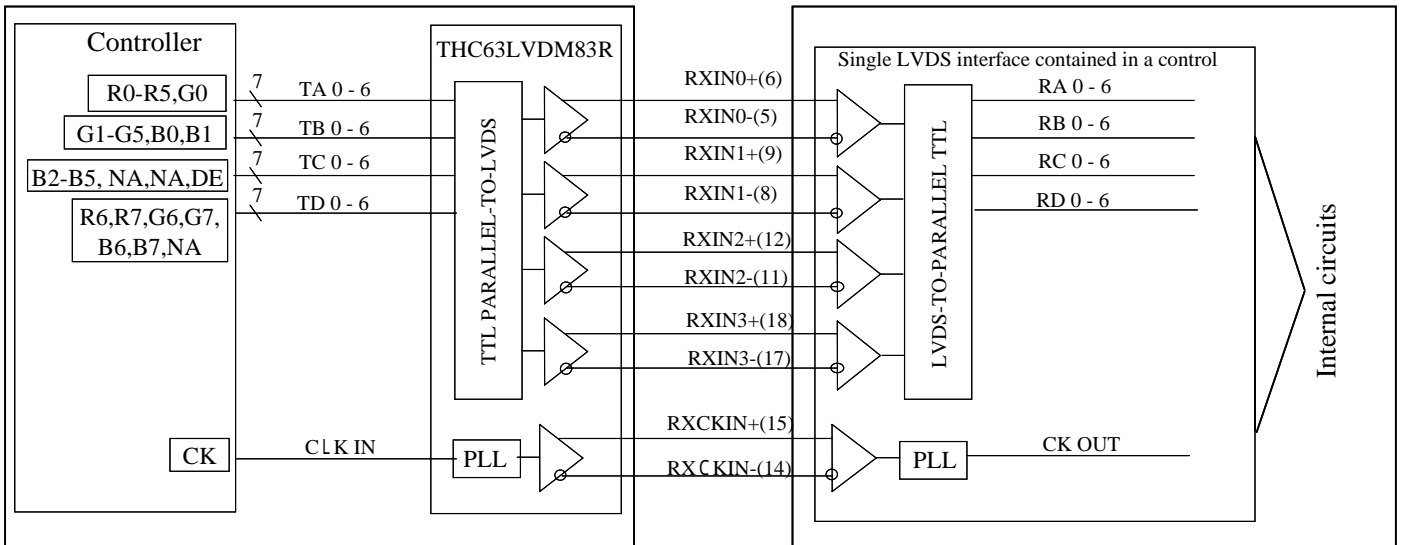

8Bit Mode
LVDS_SET=H (20 pin=3.3[V])

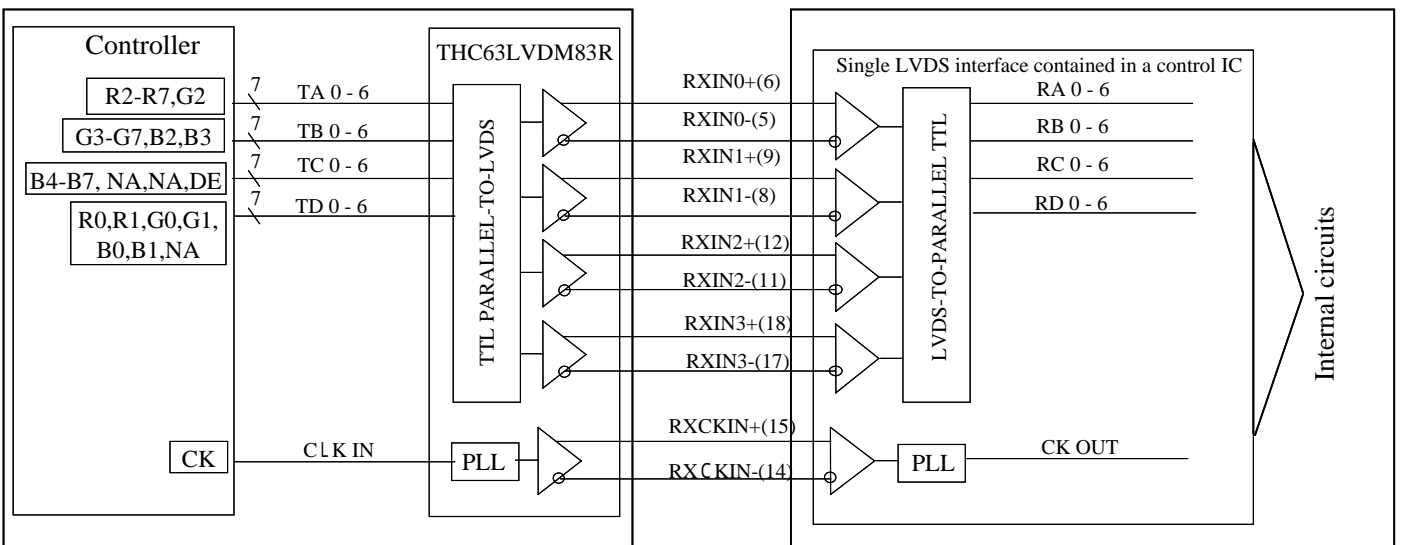

6Bit Mode
LVDS_SET=H (20 pin=3.3[V])

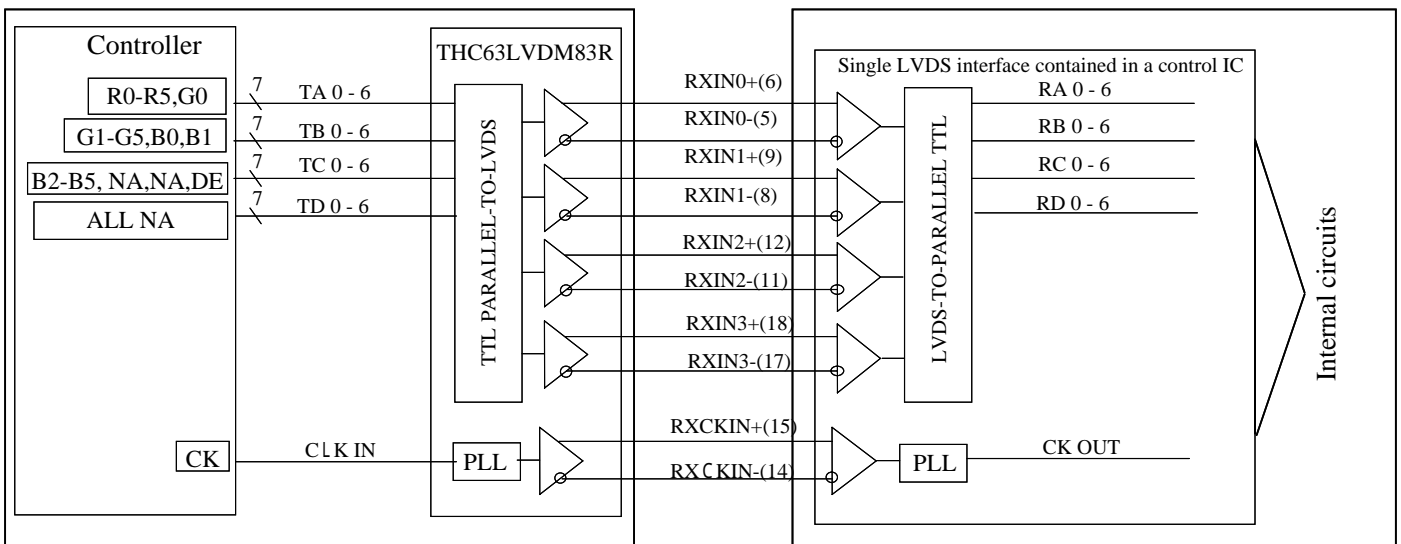

4-4. Backlight

CN 2, 3, 4, 5

The module-side connector : BHSR-02VS-1 (JST)

The user-side connector : SM02-BHSS-1-TB (JST)

Pin no.	symbol	Function	I / O	Cable color
1	V_{HIGH}	Power supply for lamp 1 (High voltage side)	I	Blue or Pink
2	V_{LOW}	Power supply for lamp 1 (Low voltage side)	I	Brown or White

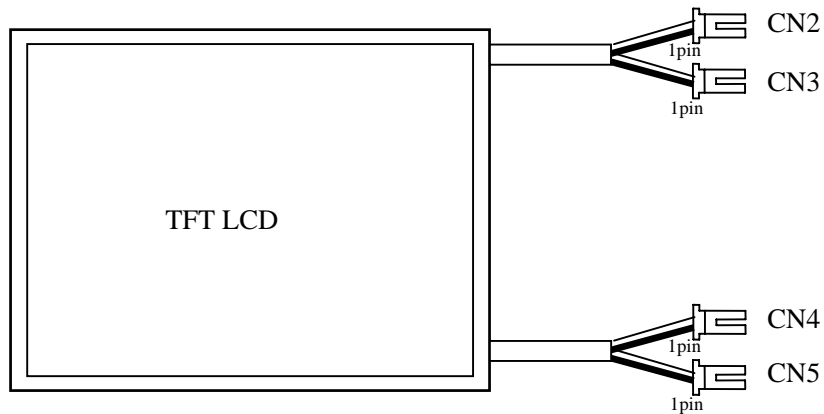

5. Absolute Maximum Ratings

5-1 module

Parameter	Symbol	Condition	Applied pin	Ratings	Unit	Remark
Supply voltage	V_{CC}	$T_a=25$	V_{CC}	- 0.3 ~ + 4.0	V	【Note1】
Lamp Input voltage	V_{HIGH}	-	-	0 ~ + 2000	V_{rms}	
Storage temperature	T_{STG}	-	-	- 30 ~ + 70		
Operating temperature (Ambient)	T_{OPA}	-	-	0 ~ + 60		
Input voltage	V_{I2}	$T_a=25$	LVDS_SET	- 0.3 ~ $V_{CC} + 0.3$	V	

【Note1】 Humidity : 95%RH Max. ($T_a < 40$) Take care of static electricity.

Maximum wet-bulb temperature at 39 or less. ($T_a > 40$) No condensation.

6. Electrical Characteristics

6-1. TFT-LCD panel driving

Ta = 25

Parameter		Symbol	Min.	Typ.	Max.	Unit	Remark
+ 3.3V	Supply voltage	V _{CC}	+3.0	+3.3	+3.6	V	【 Note1 】
	Current dissipation	I _{CC}	-	(450)	(750)	mA	【 Note2 】
Permissive input ripple voltage		V _{RF}	-	-	100	mVp-p	V _{CC} =+3.3V
Differential input threshold voltage	High	V _{TH}	-	-	100	mV	V _{CM} =+1.2V 【 Note3 】
	Low	V _{TL}	-100	-	-	mV	
Input current (High)		I _{OH}	-	-	± 10	μ A	V _I =2.4V, V _{CC} =3.6V 【 Note4 】
Input current (Low)		I _{OL}	-	-	± 10	μ A	V _I =0V, V _{CC} =3.6V 【 Note4 】
Terminal resistor		R _T	-	100	-		Differential input

【 Note1 】

On-off sequences of V_{CC} and data

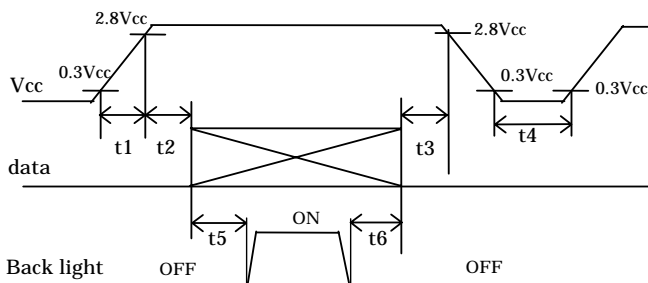

- 0 < t1 10ms
- 0 < t2 10ms
- 0 t3 1s
- 1s t4
- 20ms t5
- 20ms t6

Dip conditions for supply voltage

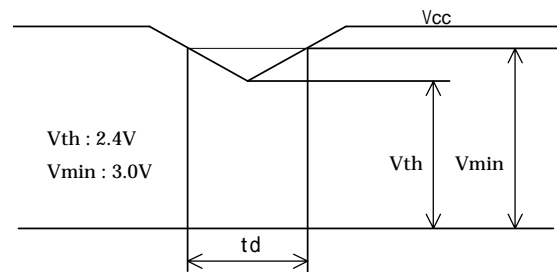

- 1) Vth Vcc Vmin
- td 10ms
- 2) Vcc Vth

V_{CC}-dip conditions should also follow the on-off conditions.

It is recommended to consider some timing difference between LVDS input and Backlight input as shown above.

If the Backlight lights on before LCD starting, or if the Backlight is kept on after LCD stopping, the screen may look white for a moment or abnormal image may be displayed. This is caused by variation in output signal from timing generator at LVDS input on or off. It does not cause the damage to the LCD module.

【 Note2 】 Typical current situation : 253-gray-bar pattern

V_{CC}=+3.3V, f_{ck}=65MHz, Ta=25

Gray scale : GS(n)

n=0 ~ 252

The explanation of each gray scale, GS(n), is described below section 8.

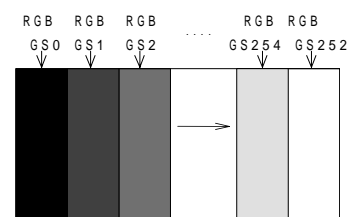

【 Note3 】 V_{CM} : LVDS Common mode voltage.

【 Note4 】 V_I : Input voltage to LVDS_SET.

6-2. Backlight

The back light system is an edge-lighting type with four CCFTs (Cold Cathode Fluorescent Tube).

The characteristics of the lamp are shown in the following table.

The value mentioned below is at the case of one CCFT.

CCFT Model Name : KTBE222MSTF-320MA262-Z (STANLEY ELECTRIC CO., LTD.)

Parameter	Symbol	Min.	Typ.	Max.	Unit	Remark
Lamp current range	I_L	3.5	5.5	7.5	mArms	【Note1】
Lamp voltage	V_L	-	645	740	Vrms	$T_a=25$, $I_L=5.5$ mArms
Lamp power consumption	P_L	-	3.55	4.1	W	【Note2】 , $I_L=5.5$ mArms
Lamp frequency	F_L	40	60	70	kHz	【Note3】
Kick-off voltage	V_s	-	-	1480	Vrms	$T_a=0$ 【Note4】
Lamp life time	T_L	50,000	-	-	hour	【Note5】

【Note1】 A lamp can be light in the range of lamp current shown above.

Maximum rating for current is measured by high frequency current measurement equipment connected to V_{LOW} at circuit showed below.

(Note : To keep enough kick-off voltage and necessary steady voltage for CCFT.)

Lamp frequency : 40 ~ 70kHz

Ambient temperature : 0 ~ 50

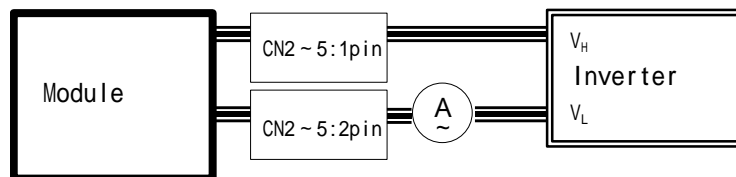

【Note2】 Referential data per one CCFT by calculation ($I_L \times V_L$).

The data don't include loss at inverter.

【Note3】 Lamp frequency may produce interference with horizontal synchronous frequency, and this may cause beat on the display. Therefore lamp frequency shall be detached as much as possible from the horizontal synchronous frequency and from the harmonics of horizontal synchronous to avoid interference.

【Note4】 This is transformer output voltage at 27pF for the ballast capacitor of a DC-AC inverter.

The kick-off voltage may rise up in the user set, please decide the open output voltage by checking not to occur lighting failure under operating state.

The open output voltage should be applied to the lamp for more than 1 second to startup. Otherwise the lamp may not be turned on.

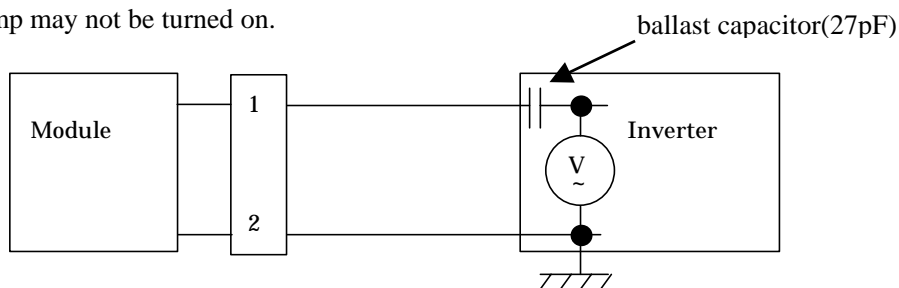

* 2pin V_{LOW}

【Note5】 Above value is applicable when the long side of LCD module is placed horizontally.

(Landscape position)

Lamp life time is defined as the time when either or occurs in the continuous operation under the condition of $T_a=25$ and $I_L=5.5$ mA rms.

Brightness becomes 50% of the original value under standard condition.

Kick-off voltage at $T_a=0$ exceeds 1480 V_{rms} value.

(Lamp lifetime may vary if LCD module is in portrait position due to the change of mercury density inside the lamp.)

《Note》

The performance of the backlight, for example lifetime or brightness, is much influenced by the characteristics of the DC-AC inverter for the lamp. When you design or order the inverter, please make sure that a poor lighting caused by the mismatch of the backlight and the inverter (miss-lighting, flicker, etc.) never occurs. When you confirm it, the module should be operated in the same condition as it is installed in your instrument.

Use the lamp inverter power source incorporating such safeguard as overvoltage / overcurrent protective circuit or lamp voltage waveform detection circuit, which should have individual control of each lamp.

In case one circuit without such individual control is connected to more than two lamps, excessive current may flow into one lamp when the other one is not in operation.

7. Timing characteristics of input signals

7-1-1. Timing characteristics

Parameter	Symbol	Min.	Typ.	Max.	Unit	Remark
Frequency	1/Tc	50.0	65.0	80.0	MHz	
Horizontal period	TH	1056	1344	1720	clock	
		16.0	20.7	23.4	μs	
Horizontal period (High)	THd	1024	1024	1024	clock	
Vertical period	TV	773	806	990	line	【Note1】
		13.3	16.7	18.0	ms	
Vertical period (High)	TVd	768	768	768	line	

【Note1】 In case of using the long vertical period, the deterioration of display quality, flicker etc. may occur.

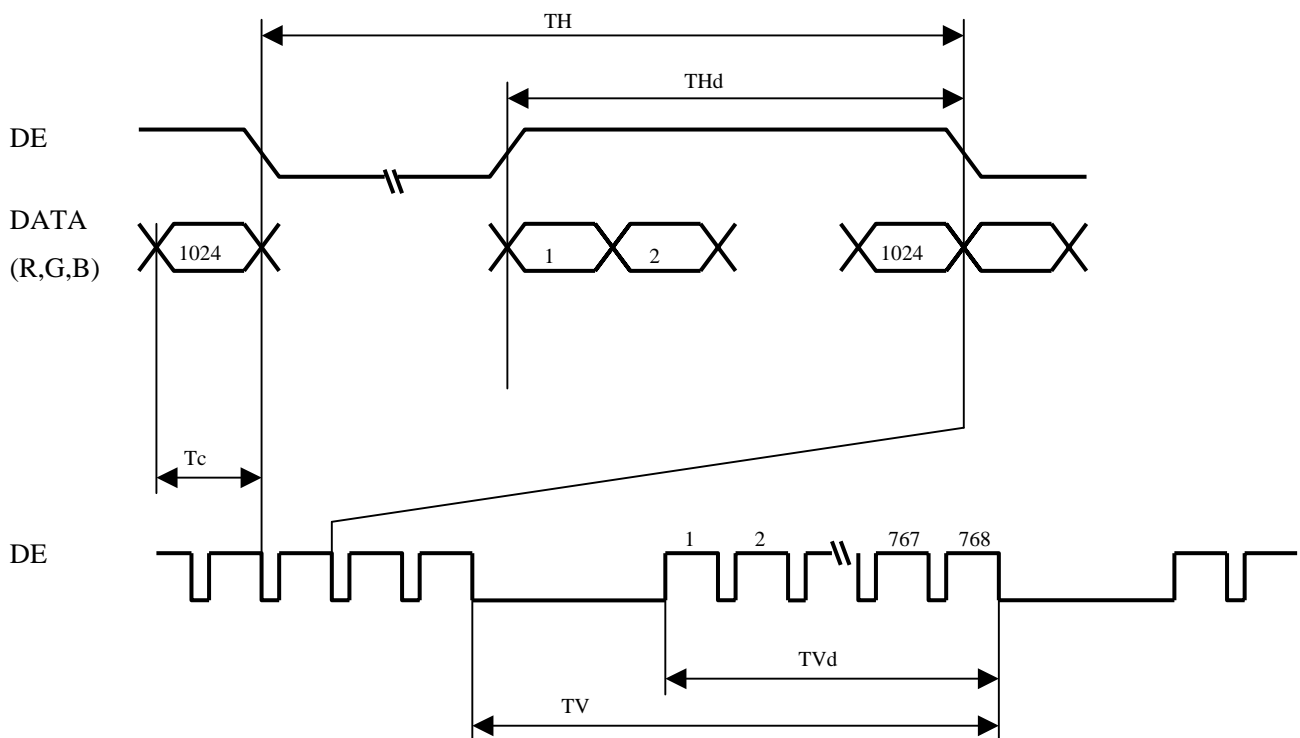

7-2 Input Data Signals and Display Position on the screen

Graphics and texts can be displayed on a 1024 × RGB × 768 dots panel with 16M colors by supplying 24 bit data signal (8bit/color [253 gray scales] × 3).

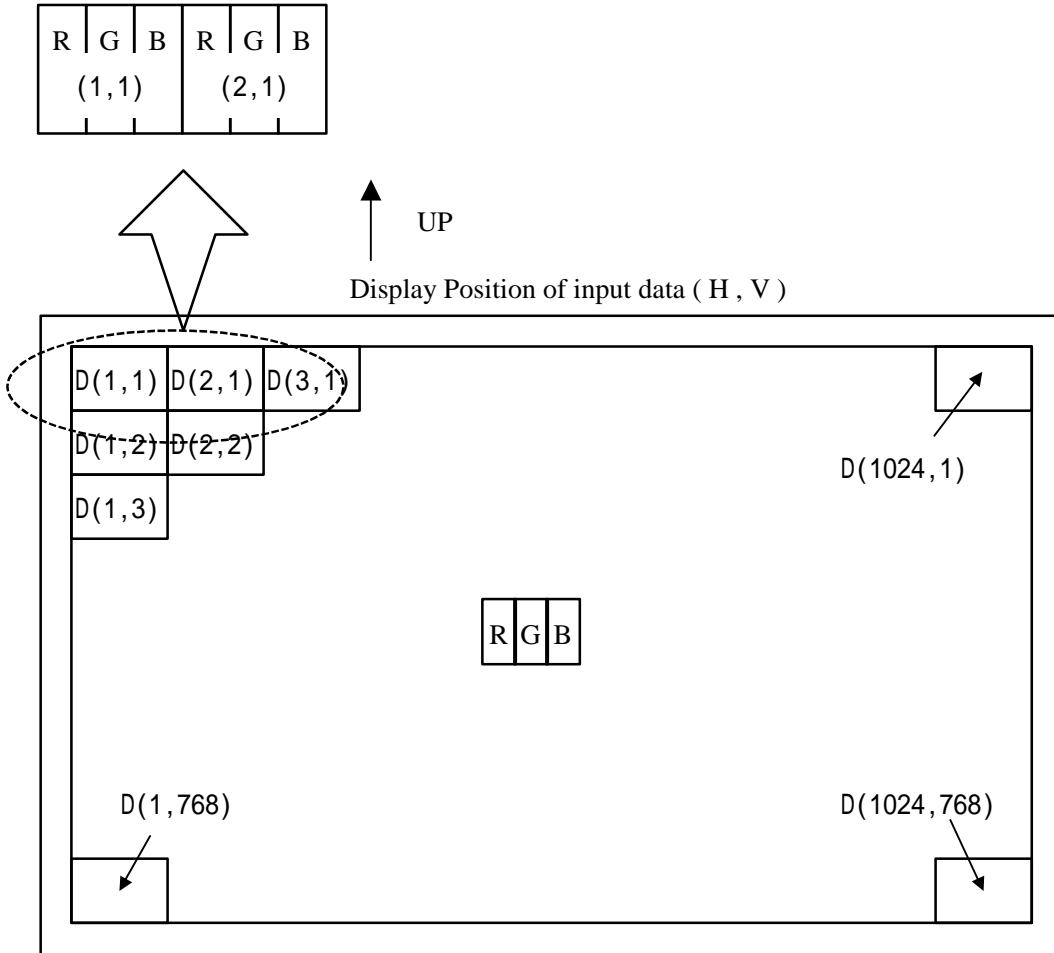

8. Input Signals, Basic Display Colors and Gray Scale of Each Color

8-1. 8bit input

	Colors & Gray scale	Data signal																											
		Gray Scale	R0	R1	R2	R3	R4	R5	R6	R7	G0	G1	G2	G3	G4	G5	G6	G7	B0	B1	B2	B3	B4	B5	B6	B7			
Basic Color	Black	-	0	0	0	0	0	0	0	0	0	0	0	0	0	0	0	0	0	0	0	0	0	0	0	0	0		
	Blue	-	0	0	0	0	0	0	0	0	0	0	0	0	0	0	0	0	X	X	1	1	1	1	1	1	1		
	Green	-	0	0	0	0	0	0	0	0	X	X	1	1	1	1	1	1	0	0	0	0	0	0	0	0	0		
	Cyan	-	0	0	0	0	0	0	0	0	X	X	1	1	1	1	1	1	X	X	1	1	1	1	1	1	1		
	Red	-	X	X	1	1	1	1	1	1	0	0	0	0	0	0	0	0	0	0	0	0	0	0	0	0	0		
	Magenta	-	X	X	1	1	1	1	1	1	0	0	0	0	0	0	0	0	X	X	1	1	1	1	1	1	1		
	Yellow	-	X	X	1	1	1	1	1	1	X	X	1	1	1	1	1	1	0	0	0	0	0	0	0	0	0		
	White	-	X	X	1	1	1	1	1	1	X	X	1	1	1	1	1	1	X	X	1	1	1	1	1	1	1		
Gray Scale of Red	Black	GS0	0	0	0	0	0	0	0	0	0	0	0	0	0	0	0	0	0	0	0	0	0	0	0	0	0		
	↑	GS1	1	0	0	0	0	0	0	0	0	0	0	0	0	0	0	0	0	0	0	0	0	0	0	0	0		
	Darker	GS2	0	1	0	0	0	0	0	0	0	0	0	0	0	0	0	0	0	0	0	0	0	0	0	0	0		
	↑	↓					↓							↓											↓				
	↓	↓					↓							↓											↓				
	Brighter	GS250	1	0	0	1	1	1	1	1	0	0	0	0	0	0	0	0	0	0	0	0	0	0	0	0	0		
	↓	GS251	1	1	0	1	1	1	1	1	0	0	0	0	0	0	0	0	0	0	0	0	0	0	0	0	0		
	Red	GS252	X	X	1	1	1	1	1	1	0	0	0	0	0	0	0	0	0	0	0	0	0	0	0	0	0		
Gray Scale of Green	Black	GS0	0	0	0	0	0	0	0	0	0	0	0	0	0	0	0	0	0	0	0	0	0	0	0	0	0		
	↑	GS1	0	0	0	0	0	0	0	0	1	0	0	0	0	0	0	0	0	0	0	0	0	0	0	0	0		
	Darker	GS2	0	0	0	0	0	0	0	0	0	1	0	0	0	0	0	0	0	0	0	0	0	0	0	0	0		
	↑	↓					↓							↓											↓				
	↓	↓					↓							↓											↓				
	Brighter	GS250	0	0	0	0	0	0	0	0	1	0	0	1	1	1	1	1	0	0	0	0	0	0	0	0	0		
	↓	GS251	0	0	0	0	0	0	0	0	1	1	0	1	1	1	1	1	0	0	0	0	0	0	0	0	0		
	Green	GS252	0	0	0	0	0	0	0	0	X	X	1	1	1	1	1	1	0	0	0	0	0	0	0	0	0		
Gray Scale of Blue	Black	GS0	0	0	0	0	0	0	0	0	0	0	0	0	0	0	0	0	0	0	0	0	0	0	0	0	0		
	↑	GS1	0	0	0	0	0	0	0	0	0	0	0	0	0	0	0	0	1	0	0	0	0	0	0	0	0		
	Darker	GS2	0	0	0	0	0	0	0	0	0	0	0	0	0	0	0	0	0	1	0	0	0	0	0	0	0		
	↑	↓					↓							↓											↓				
	↓	↓					↓							↓											↓				
	Brighter	GS250	0	0	0	0	0	0	0	0	0	0	0	0	0	0	0	0	1	0	0	1	1	1	1	1	1		
	↓	GS251	0	0	0	0	0	0	0	0	0	0	0	0	0	0	0	0	1	1	0	1	1	1	1	1	1		
	Blue	GS252	0	0	0	0	0	0	0	0	0	0	0	0	0	0	0	0	X	X	1	1	1	1	1	1	1		

0 : Low level voltage, 1 : High level voltage. X :Don't care.

Each basic color can be displayed in 253 gray scales from 8 bit data signals. According to the combination of total 24 bit data signals, the 16-million-color display can be achieved on the screen.

8-2 6bit input

	Colors & Gray scale	Data signal																		
		Gray Scale	R0	R1	R2	R3	R4	R5	G0	G1	G2	G3	G4	G5	B0	B1	B2	B3	B4	B5
Basic Color	Black	-	0	0	0	0	0	0	0	0	0	0	0	0	0	0	0	0	0	0
	Blue	-	0	0	0	0	0	0	0	0	0	0	0	0	1	1	1	1	1	1
	Green	-	0	0	0	0	0	0	1	1	1	1	1	1	0	0	0	0	0	0
	Cyan	-	0	0	0	0	0	0	1	1	1	1	1	1	1	1	1	1	1	1
	Red	-	1	1	1	1	1	1	0	0	0	0	0	0	0	0	0	0	0	0
	Magenta	-	1	1	1	1	1	1	0	0	0	0	0	0	1	1	1	1	1	1
	Yellow	-	1	1	1	1	1	1	1	1	1	1	1	1	0	0	0	0	0	0
	White	-	1	1	1	1	1	1	1	1	1	1	1	1	1	1	1	1	1	1
Gray Scale of Red	Black	GS0	0	0	0	0	0	0	0	0	0	0	0	0	0	0	0	0	0	0
	↑	GS1	1	0	0	0	0	0	0	0	0	0	0	0	0	0	0	0	0	0
	Darker	GS2	0	1	0	0	0	0	0	0	0	0	0	0	0	0	0	0	0	0
	↑	↓	↓					↓					↓							
	↓	↓	↓					↓					↓							
	Brighter	GS61	1	0	1	1	1	1	0	0	0	0	0	0	0	0	0	0	0	0
	↓	GS62	0	1	1	1	1	1	0	0	0	0	0	0	0	0	0	0	0	0
	Red	GS63	1	1	1	1	1	1	0	0	0	0	0	0	0	0	0	0	0	0
Gray Scale of Green	Black	GS0	0	0	0	0	0	0	0	0	0	0	0	0	0	0	0	0	0	0
	↑	GS1	0	0	0	0	0	0	1	0	0	0	0	0	0	0	0	0	0	0
	Darker	GS2	0	0	0	0	0	0	0	1	0	0	0	0	0	0	0	0	0	0
	↑	↓	↓					↓					↓							
	↓	↓	↓					↓					↓							
	Brighter	GS61	0	0	0	0	0	0	1	0	1	1	1	1	0	0	0	0	0	0
	↓	GS62	0	0	0	0	0	0	0	1	1	1	1	1	0	0	0	0	0	0
	Green	GS63	0	0	0	0	0	0	1	1	1	1	1	1	0	0	0	0	0	0
Gray Scale of Blue	Black	GS0	0	0	0	0	0	0	0	0	0	0	0	0	0	0	0	0	0	0
	↑	GS1	0	0	0	0	0	0	0	0	0	0	0	0	1	0	0	0	0	0
	Darker	GS2	0	0	0	0	0	0	0	0	0	0	0	0	0	1	0	0	0	0
	↑	↓	↓					↓					↓							
	↓	↓	↓					↓					↓							
	Brighter	GS61	0	0	0	0	0	0	0	0	0	0	0	0	1	0	1	1	1	1
	↓	GS62	0	0	0	0	0	0	0	0	0	0	0	0	0	1	1	1	1	1
	Blue	GS63	0	0	0	0	0	0	0	0	0	0	0	0	1	1	1	1	1	1

0 : Low level voltage, 1 : High level voltage.

Each basic color can be displayed in 64 gray scales from 6 bit data signals. According to the combination of total 18 bit data signals, the 262,144-color display can be achieved on the screen.

9. Optical Characteristics

Ta=25 , Vcc =+3.3V

Parameter		Symbol	Condition	Min.	Typ.	Max.	Unit	Remark
Viewing angle range	Vertical	11	CR 5	(40)	(55)	-	Deg.	
		12		(70)	(80)	-	Deg.	
	Horizontal	21, 22		(70)	(80)	-	Deg.	
	Vertical	11	CR 10	(30)	(45)	-	Deg.	
		12		(45)	(55)	-	Deg.	
	Horizontal	21, 22		(50)	(60)	-	Deg.	
Contrast ratio		C R	=0 °	(250)	(350)	-	-	【Note2,4】
Response time		d + r	=0 °	-	(30)	(60)	ms	【Note3,4】
Chromaticity of White		Wx	=0 °	0.283	0.313	0.343	-	【Note4】
		Wy		0.299	0.329	0.359	-	
Chromaticity of Red		Rx	=0 °	0.551	0.581	0.611	-	
		Ry		0.292	0.322	0.352	-	
Chromaticity of Green		Gx	=0 °	0.277	0.307	0.337	-	
		Gy		0.516	0.546	0.576	-	
Chromaticity of Blue		Bx	=0 °	0.121	0.151	0.181	-	
		By		0.097	0.127	0.157	-	
Luminance of white		YL	=0 °	-	500	-	cd/m ²	IL=5.5mA rms f=60kHz 【Note4】
White Uniformity		w	=0 °	-	-	1.25	-	【Note5】

The measurement shall be executed 30 minutes after lighting at rating.

The optical characteristics shall be measured in a dark room or equivalent state with the method shown in Fig.2 below.

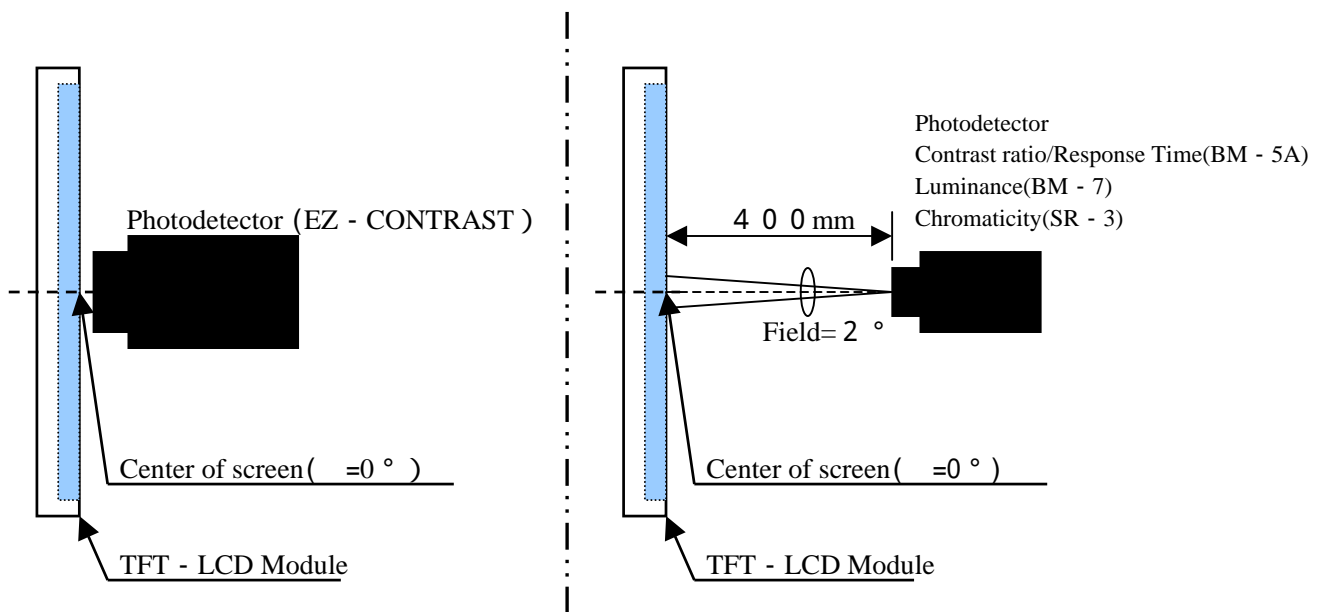
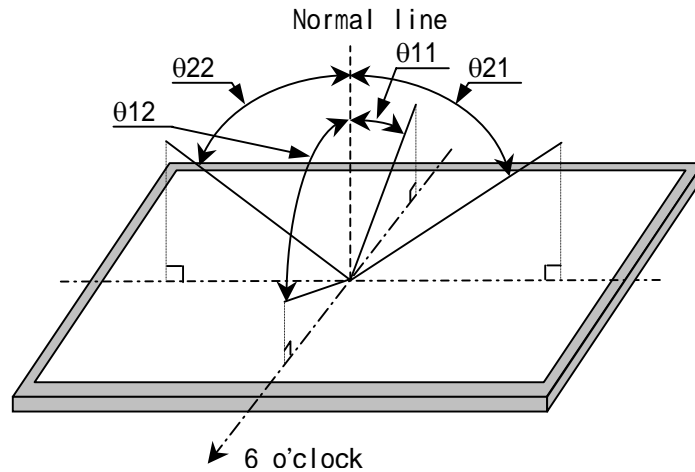

Fig2 Optical characteristics measurement method

【Note1】 Definitions of viewing angle range:



【Note2】 Definition of contrast ratio:

The contrast ratio is defined as the following.

$$\text{Contrast Ratio (CR)} = \frac{\text{Luminance (brightness) with all pixels white}}{\text{Luminance (brightness) with all pixels black}}$$

【Note3】 Definition of response time:

The response time is defined as the following figure and shall be measured by switching the input signal for "black" and "white".

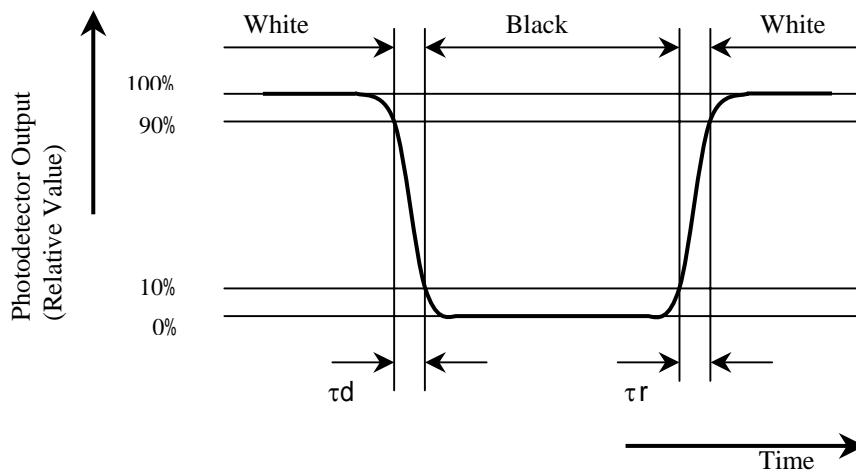

【Note4】 This shall be measured at center of the screen.

【Note5】 Definition of white uniformity:

White uniformity is defined as the following with five measurements (A ~ E).

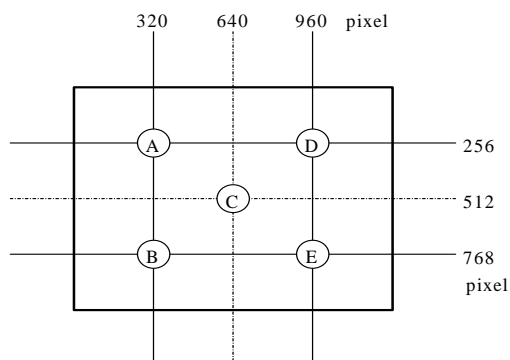

$$w = \frac{\text{Maximum Luminance of five points (brightness)}}{\text{Minimum Luminance of five points (brightness)}}$$

10. Handling Precautions

- a) Be sure to turn off the power supply when inserting or disconnecting the cable.
- b) Be sure to design the cabinet so that the module can be installed without any extra stress such as warp or twist.
- c) Since the front polarize is easily damaged, pay attention not to scratch it.
- d) Since long contact with water may cause discoloration or spots, wipe off water drop immediately.
- e) When the panel surface is soiled, wipe it with absorbent cotton or other soft cloth.
- f) Since the panel is made of glass, it may break or crack if dropped or bumped on hard surface. Handle with care.
- g) Since CMOS LSI is used in this module, take care of static electricity and take the human earth into consideration when handling.
- h) Make sure the four mounting holes of the module are grounded sufficiently. Take electro-magnetic interference (EMI) into consideration.
- i) The module has some printed circuit boards (PCBs) on the back side. Take care to keep them from any stress or pressure when handling or installing the module; otherwise some of electronic parts on the PCBs may be damaged.
- j) Observe all other precautionary requirements in handling components.
- k) Since it is necessary to remove the screw on the back of a module before performing lamp exchange, please take a cabinet design into consideration.
- l) When some pressure is added onto the module from rear side constantly, it causes display non-uniformity issue, functional defect, etc. So, please avoid such design.
- m) When handling LCD modules and assembling them into cabinets, please be noted that long-term storage in the environment of oxidization or deoxidization gas and the use of such materials as reagent, solvent, adhesive, resin, etc. which generate these gasses, may cause corrosion and discoloration of the LCD modules.

11. Packing form

- a) Piling number of cartons : maximum 5 cartons
- b) Packing quantity in one carton : 5 module
- c) Carton size : 319mm(W) × 402mm(D) × 280mm(H)
- d) Total mass of one carton filled with full modules : (8.2kg)
- e) Packing form is shown in Fig.3

12 . Reliability test items

No	Test item	Conditions	
1	High temperature storage test	Ta = 60 240H	
2	Low temperature storage test	Ta = -25 240H	
3	High temperature & high humidity operation test	Ta = 40 , 95%RH 240H (No condensation)	
4	High temperature operation test	Ta = 50 240H (The panel temp. must be less than 60)	
5	Low temperature operation test	Ta = 0 240H	
6	Vibration test	Waveform : Sine wave Frequency : 10 ~ 57Hz/Vibration width (one side) : 0.075mm : 58 ~ 500Hz/Gravity : 9.8m/s ² Sweep time : 11minutes Test period : 3 hours (1 hour for each direction of X,Y,Z)	【Note】
7	Shock test	Max. gravity : 490m/s ² Pulse width : 11ms, sine wave Direction : ± X, ± Y, ± Z, once for each direction.	【Note】
8	Thermal shock test (non- operating)	Ta=-25 ~ 60 ; 5 cycles Test period : 10 hours (1 hour for each temperature)	
9	Altitude	Ta=50 ,70kPa,3,048m(10,000ft), t=24H (Operating) Ta=70 ,12kPa,15,240m(50,000ft), t=24H (Storage)	

【Note】

A gap of panel shall not occur by vibration or the shock.

【Result Evaluation Criteria】

Under the display quality test conditions with normal operation state, these shall be no change which may affect practical display function.

13 . Others

1) Lot No. and indication Bar Code Label:

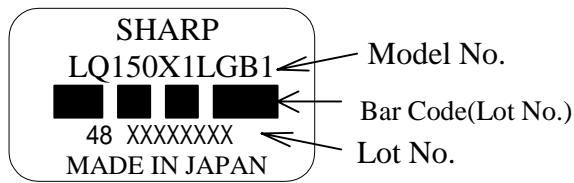

How to express Lot No.

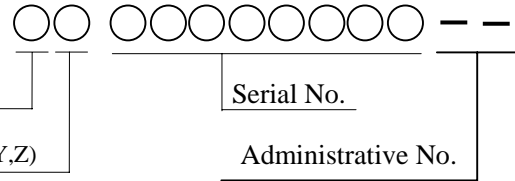

2) Packing Label

社内品番 : (4 S) LQ150X1LGB1	
Bar code ()	
LotNO .	:(1 T) 2 0 0 4 . 0 8 . 0 2
Bar code ()	
Quantity : (Q)	pcs
Bar code ()	
ユーザ品番	:
シャープ物流用ラベルです。	

Model No. (LQ150X1LGB1)

Lot No. (Date)

Quantity

3) Adjusting volume have been set optimally before shipment, so do not change any adjusted value.

If adjusted value is changed, the specification may not be satisfied.

4) Disassembling the module can cause permanent damage and should be strictly avoided.

5) Please be careful since image retention may occur when a fixed pattern is displayed for a long time.

6) The chemical compound which causes the destruction of ozone layer is not being used.

7) Warning of mercury and material information of LPG (Light Pipe Guide) are labeled on the back of the module.

MATERIAL INFORMATION
>PLASTIC LIGHT GUIDE:PMMA<

8) Cold cathode fluorescent lamp in LCD PANEL contains a small amount of mercury, Please follow local ordinances or regulations for disposal. (put on the back of the module.)

COLD CATHODE FLUORESCENT LAMP IN LCD PANEL
CONTAINS A SMALL AMOUNT OF MERCURY, PLEASE
FOLLOW LOCAL ORDINANCES OR REGULATION FOR DISPOSAL
当該液晶ディスプレイパネルは蛍光管が組み込まれていますので、地方自治体の条例、または、規則に従って廃棄ください。

9) When any question or issue occurs, it shall be solved by mutual discussion.

14. Carton storage condition

Temperature 0 to 40

Humidity 95%RH or less

Reference condition : 20 to 35 , 85%RH or less (summer)

: 5 to 15 , 85%RH or less (winter)

• the total storage time (40 ,95%RH) : 240H or less

Sunlight Be sure to shelter a product from the direct sunlight.

Atmosphere Harmful gas, such as acid and alkali which bites electronic components and/or wires must not be detected.

Notes Be sure to put cartons on palette or base, don't put it on floor, and store them with removing from wall

Please take care of ventilation in storehouse and around cartons, and control changing temperature is within limits of natural environment

Storage period 1 year

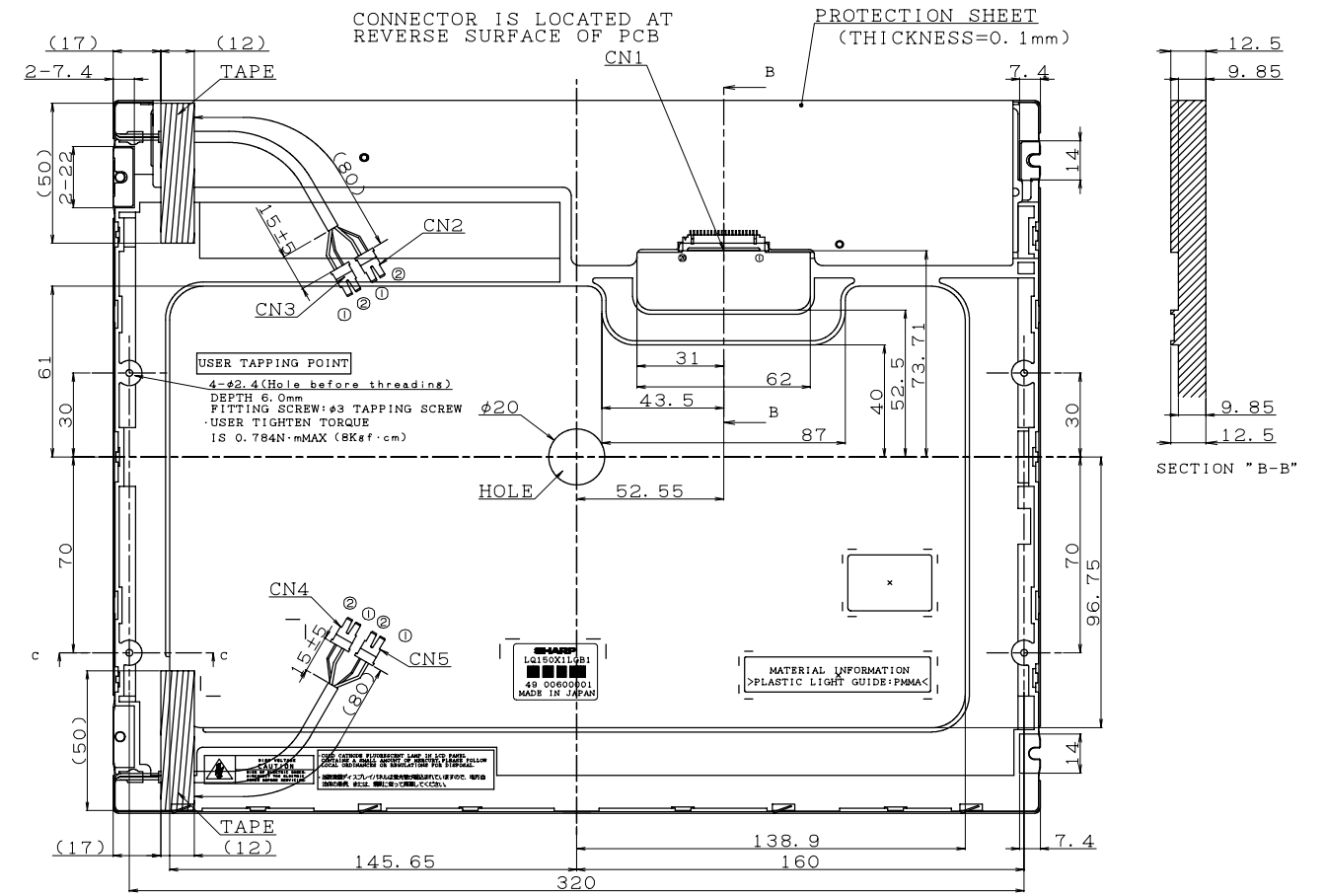
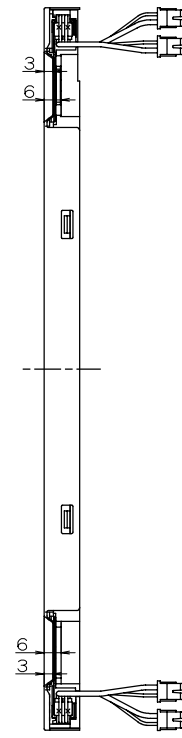
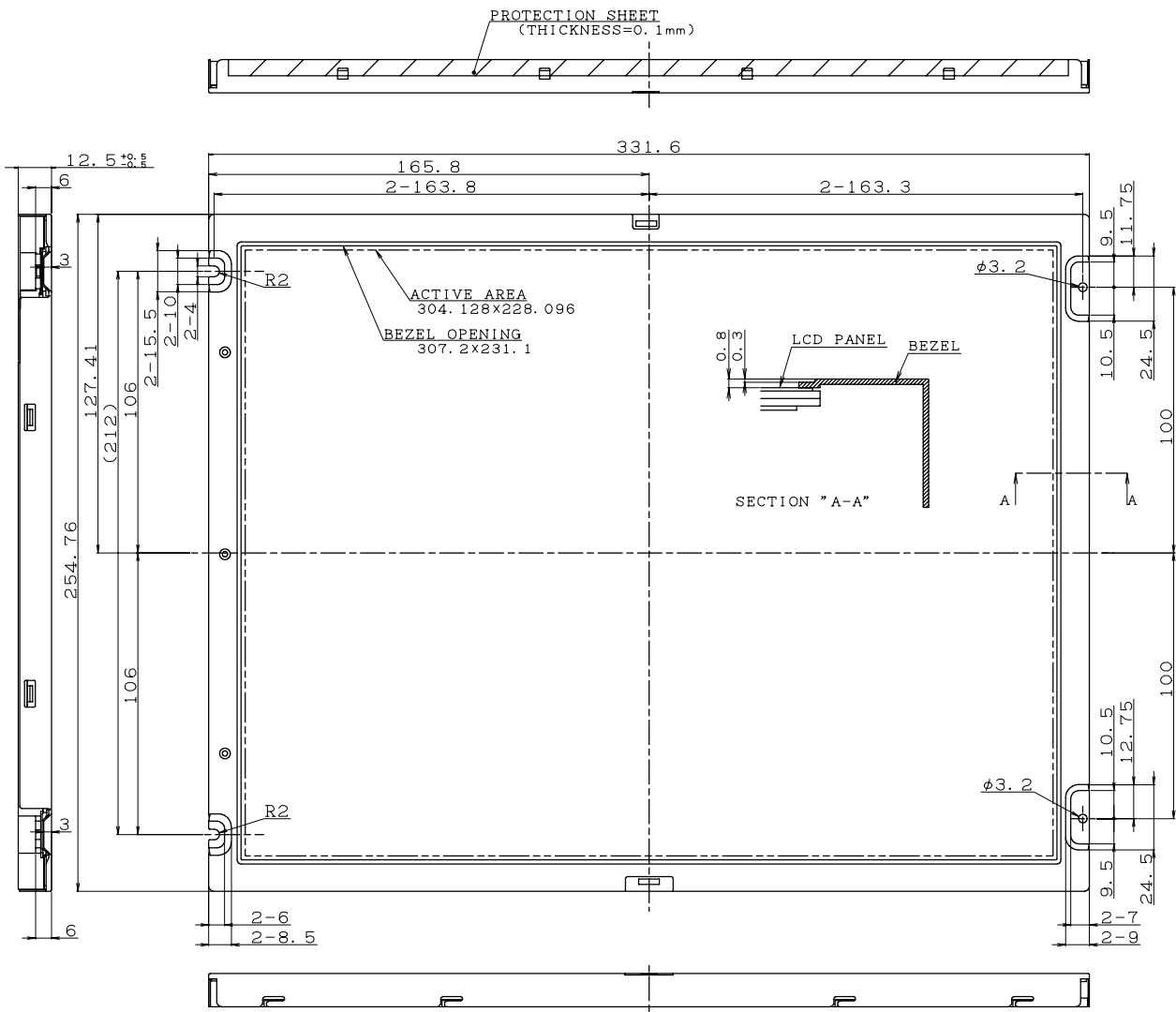

BEZEL/DISPLAY POSITION

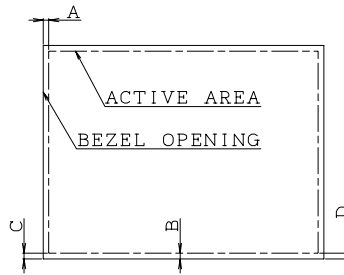

- 1) TOLERANCE X-DIRECTION A: 1.5±0.8
- 2) TOLERANCE Y-DIRECTION B: 1.5±0.8
- 3) OBLIQUITY OF DISPLAY AREA |C-D| < 0.8

【INTERFACE CONNECTOR】
CN1: DF14H-20P-1.25H(HIROSE)

【CCFT CONNECTOR】
CN2/CN3/CN4/CN5
BHSR-02VS-1(JST)

1	High
2	GND

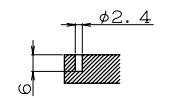

- 1. UNSPECIFIED TOLERANCE TO BE ±0.5
- 2. WARP AND FLATNESS FOR PCB AND CHASSIS ARE EXCLUDED FROM THICKNESS AND DIMENSION OF THE UNIT.
- 3. THE THICKNESS IS EXCEPT FOR PORTION OF PROTECTION SHEET.
- 4. GAP BETWEEN BEZEL AND LCD PANEL ≤ 0.5

15" LCD MODULE OUTLINE DIMENSIONS

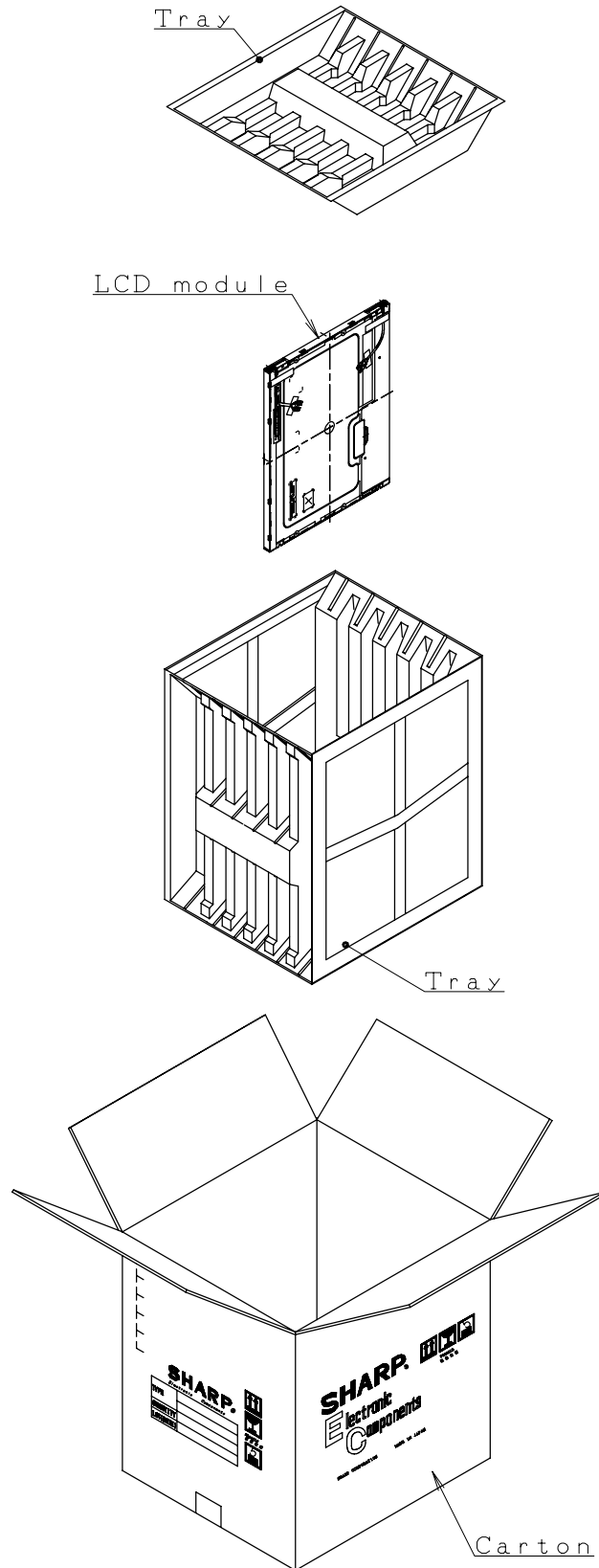

Fig 3: PACKING FORM