



Approval

Customer : \_\_\_\_\_ DATE : Feb. 20. 2012

**SAMSUNG TFT-LCD**  
**MODEL : LTI460HN05**

The Information Described in this Specification is Preliminary and can be changed without prior notice

NOTE :

| Customer's Approval |      |
|---------------------|------|
| SIGNATURE           | DATE |
|                     |      |

|                                     |                      |
|-------------------------------------|----------------------|
| APPROVED BY<br><i>Heo Jeongmin</i>  | DATE<br>Feb.20. 2012 |
| PREPARED BY<br><i>ChangHee Hong</i> | DATE<br>Feb.20. 2012 |

Application Engineering Part, LCD Business

Samsung Electronics Co . , LTD.

Revision History ----- (3)

General Description ----- (4)

General Information ----- (4)

1. Absolute Maximum Ratings ----- (5)

2. Application information for DID (Digital Information Display) ----- (6)

3. Optical Characteristics ----- (7)

4. Electrical Characteristics ----- (10)

    4.1 TFT LCD Module

    4.2 Back Light Unit

    4.3 Inverter Input & Specification

5. Input Terminal Pin Assignment ----- (13)

    5.1 LVDS Connector

    5.2 Inverter Input Pin Configuration

    5.3 Inverter Input Power Sequence

    5.4 LVDS Interface

    5.5 Input Signals, Basic Display Colors and Gray Scale of Each Color

6. Interface Timing ----- (18)

    6.1 Timing Parameters (DE mode)

    6.2 Timing Diagrams of interface Signal (DE mode)

    6.3 Power ON/OFF Sequence

7. Outline Dimension ----- (21)

8. Reliability ----- (23)

9. Packing ----- (24)

10. Marking & Others ----- (26)

11. General Precaution ----- (27)

    11.1 Handling

    11.2 Storage

    11.3 Operation

    11.4 Operation Condition Guide

    11.5 Others

**\* Revision History**

| Date           | Rev. No | Page | Summary               |
|----------------|---------|------|-----------------------|
| Feb. 20. 2012. | 000     | all  | - First issued for GA |

## General Description

### Description

LTI460HN05 is a color active matrix liquid crystal display (LCD) that uses amorphous silicon TFT(Thin Film Transistor) as switching components. This model is composed of a TFT LCD panel, a driver circuit and a backlight unit. The resolution of a 46.0" is 1920 x 1080 and this model can display up to 16.7 million colors with wide viewing angle of 89° or higher in all directions. This panel is intended to support applications to provide a excellent performance for Flat Panel Display such as Home-alone Multimedia TFT-LCD TV, Display terminals for AV application products, and Digital Information Display (DID).

### Features

- RoHS compliance (Pb-free)
- High contrast ratio, High luminance
- SVA(Super Vertical Align) mode
- Wide viewing angle ( $\pm 178^\circ$ )
- High speed response
- Landscape / Portrait type compatible
- Wide UXGA (1920 x 1080 pixels) resolution (16:9)
- Low power consumption
- Direct Type 12 CCFTs(Cold Cathode Fluorescent Tube)
- DE(Data Enable) mode
- High Tni (85 °C) Liquid crystal
- 2Ch - LVDS (Low Voltage Differential Signaling) interface (2pixel/clock)

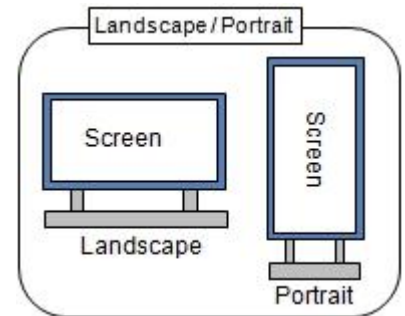

### General Information

| Items               | Specification  | Unit              | Note     |
|---------------------|--|-------------------|----------|
| Module Size         | 1047.4(W <sub>TYP</sub> ) x 600.6(H <sub>TYP</sub> ) | mm                | ± 1.0 mm |
|                     | 66(D <sub>Max</sub> )                                |                   | ± 1.0 mm |
| Weight              | 14,500   | g                 | Max      |
| Pixel Pitch         | 0.53025(H) x 0.53025(V)                              | mm                |          |
| Active Display Area | 1018.08(H) x 572.67(V)                               | mm                |          |
| Surface Treatment   | Haze 44% , Hard-coating (3H)                         |                   |          |
| Display Colors      | 8 bit - 16.7M  | colors            |          |
| Number of Pixels    | 1920 x 1080  | pixel             |          |
| Pixel Arrangement   | RGB vertical stripe                                  |                   |          |
| Display Mode        | Normally Black                                       |                   |          |
| Luminance of White  | 700 (Typ.)   | cd/m <sup>2</sup> |          |

# 1. Absolute Maximum Ratings

If the condition exceeds maximum ratings, it can cause malfunction or unrecoverable damage to the device.

| Item                                  | Symbol                 | Min.    | Max. | Unit | Note    |     |
|---------------------------------------|------------------------|---------|------|------|---------|-----|
| Power Supply Voltage                  | $V_{DD}$               | GND-0.5 | 13.2 | V    | (1)     |     |
| Storage temperature                   | $T_{STG}$              | -20     | 60   | °C   | (2)     |     |
| Glass surface temperature (Operation) | Center<br>$T_{CENTER}$ | 0       | 50   | °C   | (2),(5) |     |
| Shock (Non-operating)                 | $S_{nop}$              | x,y     | -    | 40   | G       | (3) |
|                                       |                        | z       | -    | 30   |         |     |
| Vibration (Non-operating)             | $V_{nop}$              | -       | 1.5  | G    | (4)     |     |

Note (1)  $T_a = 25 \pm 2 \text{ }^\circ\text{C}$

(2) Temperature and relative humidity range are shown in the figure below.

- a. 90 % RH Max. ( $T_a \leq 39 \text{ }^\circ\text{C}$ )
- b. Relative Humidity is 90% or less. ( $T_a > 39 \text{ }^\circ\text{C}$ )
- c. No condensation

(3) 11ms, Sine wave, one time for  $\pm X, \pm Y, \pm Z$  axis

(4) 10-300Hz, Sweep rate 10min, 30min for X,Y,Z axis

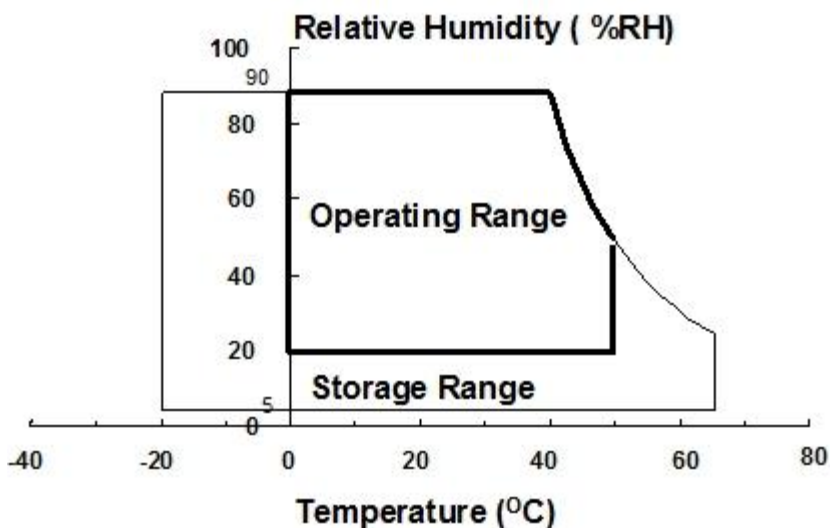

(5) Definition of test point

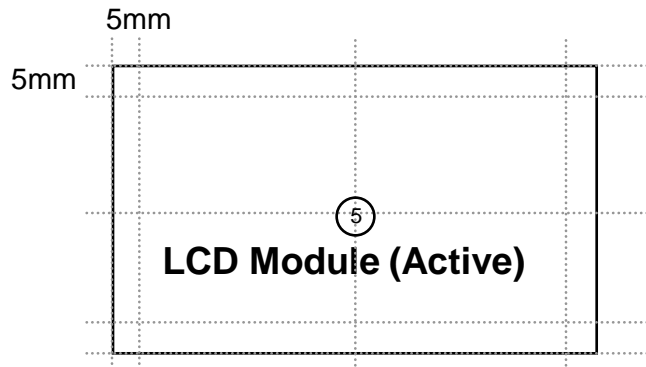

$T_{\text{CENTER}}$  : Temperature of the center of the glass surface (Test point 5)

## 2. Application information for DID (Digital Information Display)

A long-term display like DID application may cause uneven display including image retention. To optimize module's lifetime and function, several operating usages are required.

1. Normal operating condition

- Temperature:  $20 \pm 15^{\circ}\text{C}$
- Humidity:  $55 \pm 20\%$
- Display pattern: moving picture or regular switchover display

Note) Long-term static information image may cause uneven display.

2. Operating usages under abnormal operating condition. Note (1)

- a. Ambient condition
  - Well-ventilated place is recommended to set up DID system.
- b. Power off and screen saver
  - Periodical power-off or screen saver is needed after long-term static display. Note (2)

3. Operating usages to protect uneven display due to long-term static information display

- a. Suitable operating time for P-DID : under 20 hours a day.
- b. Periodical display contents change from static image to moving picture.
  - Liquid crystal refresh time is required.
- c. Periodical background color and character (image) color change
  - Use different colors for background and character (image), respectively.
  - Change colors periodically.
- d. Avoid combination of background and character with large different luminance.

Note (1) Abnormal condition means every operating condition except normal operating condition.

Note (2) Moving picture or black pattern is strongly recommended for screen saver.

4. Lifetime in this spec is guaranteed only when DID is used under right operating usages.

### 3. Optical Characteristics

The optical characteristics should be measured in a dark room or equivalent.  
 Measuring equipment : TOPCON BM-7,SPECTRORADIOMETER SR-3

( $T_a = 25 \pm 2^\circ\text{C}$ ,  $V_{DD} = 12\text{V}$ ,  $f_V = 60\text{Hz}$ ,  $f_{DCLK} = 148.5\text{ MHz}$ ,  $I_L = 14\text{mA}$ )

| Item                                     | Symbol    | Condition  | Min.          | Typ.          | Max.  | Unit              | Note        |                 |
|--|-----------|--|---------------|---------------|-------|-------------------|-------------|-----------------|
| Contrast Ratio<br>(Center of screen)     | C/R       | Normal<br>$\theta_{L,R}=0$<br>$\theta_{U,D}=0$<br><br>Viewing<br>Angle | 2000          | 3000          | -     |                   | (3)<br>SR-3 |                 |
| Response Time<br>G-to-G                  | Tg        |  | -             | 8             | 16    | msec              | (5)<br>BM-7 |                 |
| Luminance of White<br>(Center of screen) | $Y_L$     |  | 550           | 700           | -     | cd/m <sup>2</sup> | (6)<br>SR-3 |                 |
| Color Chromaticity<br>(CIE 1931)         | Red       |  | Rx            | TYP.<br>-0.03 | 0.640 | TYP.<br>+0.03     |             | (7),(8)<br>SR-3 |
|  |           |  | Ry            |               | 0.330 |                   |             |                 |
|  | Green     |  | Gx            |               | 0.300 |                   |             |                 |
|  |           |  | Gy            |               | 0.600 |                   |             |                 |
|  | Blue      |  | Bx            |               | 0.150 |                   |             |                 |
|  |           |  | By            |               | 0.060 |                   |             |                 |
|  | White     |  | Wx            |               | 0.280 |                   |             |                 |
|  |           | Wy   | 0.290         |               |       |                   |             |                 |
| Color Gamut                              | -         | -  | 72            | -             | %     | (7)<br>SR-3       |             |                 |
| Color Temperature                        | -         | -  | 10000         | -             | K     | (7)<br>SR-3       |             |                 |
| Viewing Angle                            | Hor.      | $\theta_L$   | C/R $\geq$ 10 | 75            | 89    | -                 | Degree      | (8)<br>SR-3     |
|  |           | $\theta_R$   |               | 75            | 89    | -                 |             |                 |
|  | Ver.      | $\theta_U$   |               | 75            | 89    | -                 |             |                 |
|  |           | $\theta_D$   |               | 75            | 89    | -                 |             |                 |
| Brightness Uniformity<br>(9 Points)      | $B_{uni}$ | -  | -             | 25            | %     | (4)<br>SR-3       |             |                 |

Note (1) Test Equipment Setup

The measurement should be executed in a stable, windless and dark room between 40min and 60min after lighting the backlight at the given temperature for stabilization of the backlight. This should be measured in the center of screen.

Single lamp current : 14.0 mA  
 Environment condition :  $T_a = 25 \pm 2^\circ\text{C}$

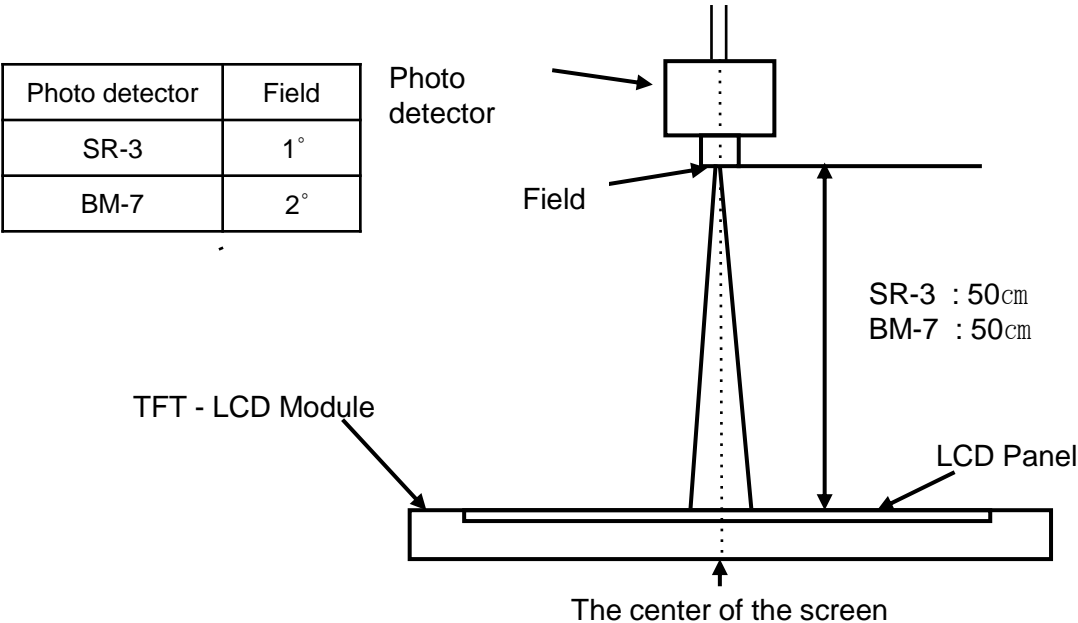

Note (2) Definition of test point

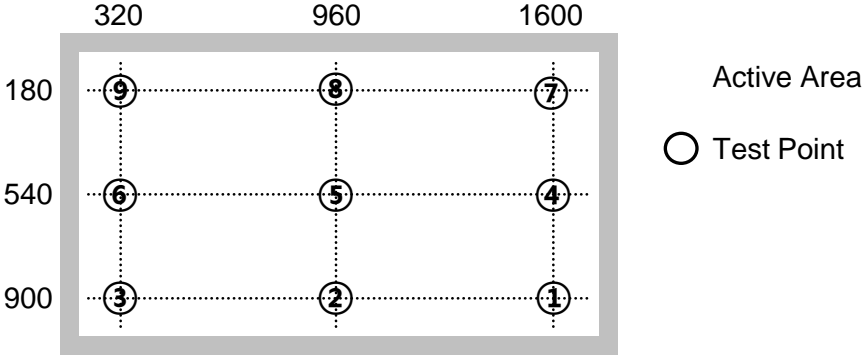

Note (3) Definition of Contrast Ratio (C/R)

: Ratio of gray max (Gmax) & gray min (Gmin) at the center point ⑤ of the panel

$$C/R = \frac{G_{max}}{G_{min}}$$

Gmax : Luminance with all pixels white  
 Gmin : Luminance with all pixels black

Note (4) Definition of 9 points brightness uniformity

$$B_{uni} = 100 * \frac{(B_{max} - B_{min})}{B_{max}}$$

Bmax : Maximum brightness  
 Bmin : Minimum brightness



Note (5) Definition of Response time : Average response time of all Gray to Gray

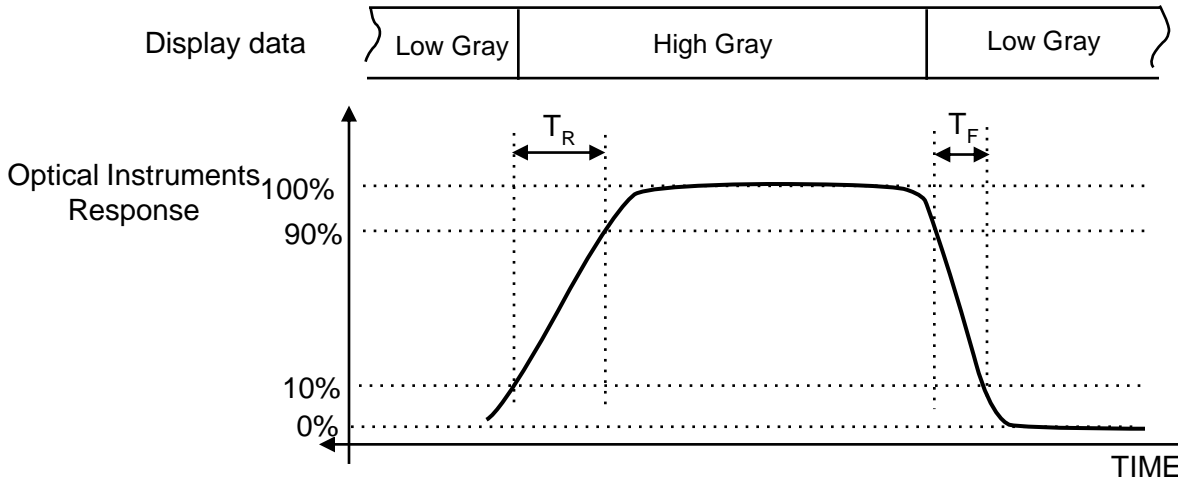

| Gray to Gray Response Time |      |           |            |            |            |             |             |             |             |             |     |
|----------------------------|------|-----------|------------|------------|------------|-------------|-------------|-------------|-------------|-------------|-----|
|                            | Gray | End       |            |            |            |             |             |             |             |             |     |
|                            |      | 0         | 31         | 63         | 95         | 127         | 159         | 191         | 223         | 255         |     |
| Start                      | 0    |           | Tr(0-31)   | Tr(0-63)   | Tr(0-95)   | Tr(0-127)   | Tr(0-159)   | Tr(0-191)   | Tr(0-223)   | Tr(0-255)   | Ton |
|                            | 31   | Tf(31-0)  |            | Tr(31-63)  | Tr(31-95)  | Tr(31-127)  | Tr(31-159)  | Tr(31-191)  | Tr(31-223)  | Tr(31-255)  |     |
|                            | 63   | Tf(63-0)  | Tf(63-31)  |            | Tr(63-95)  | Tr(63-127)  | Tr(63-159)  | Tr(63-191)  | Tr(63-223)  | Tr(63-255)  |     |
|                            | 95   | Tf(95-0)  | Tf(95-31)  | Tf(95-63)  |            | Tr(95-127)  | Tr(95-159)  | Tr(95-191)  | Tr(95-223)  | Tr(95-255)  |     |
|                            | 127  | Tf(127-0) | Tf(127-31) | Tf(127-63) | Tf(127-95) |             | Tr(127-159) | Tr(127-191) | Tr(127-223) | Tr(127-255) |     |
|                            | 159  | Tf(159-0) | Tf(159-31) | Tf(159-63) | Tf(159-95) | Tf(159-127) |             | Tr(159-191) | Tr(159-223) | Tr(159-255) |     |
|                            | 191  | Tf(191-0) | Tf(191-31) | Tf(191-63) | Tf(191-95) | Tf(191-127) | Tf(191-159) |             | Tr(191-223) | Tr(191-255) |     |
|                            | 223  | Tf(223-0) | Tf(223-31) | Tf(223-63) | Tf(223-95) | Tf(223-127) | Tf(223-159) | Tf(223-191) |             | Tr(223-255) |     |
|                            | 255  | Tf(255-0) | Tf(255-31) | Tf(255-63) | Tf(255-95) | Tf(255-127) | Tf(255-159) | Tf(255-191) | Tf(255-223) |             |     |
| Toff                       |      |           |            |            |            |             |             |             |             |             |     |

T\*(X-Y) : Response time from level of gray(X) to level of gray(Y)

**Response time Definition** =  $\sum [T^*(X-Y)] / 72$

Note (6) Definition of Luminance of White : Luminance of white at center point ⑤

Note (7) Definition of Color Chromaticity (CIE 1931)

Color coordinate of Red, Green, Blue & White at center point ⑤

Note (8) Definition of Viewing Angle

: Viewing angle range (C/R ≥ 10)

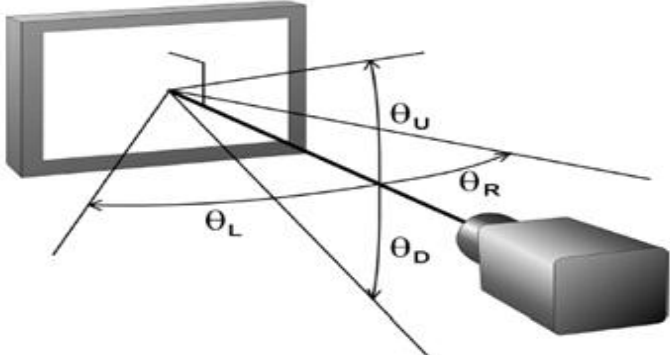

## 4. Electrical Characteristics

### 4.1 TFT LCD Module

The connector for display data & timing signal should be connected.

Ta = 25°C ± 2 °C

| Item                    | Symbol      | Min.  | Typ.  | Max.   | Unit | Note    |
|-------------------------|-------------|-------|-------|--------|------|---------|
| Voltage of Power Supply | $V_{DD}$    | 10.8  | 12.0  | 13.2   | V    | (1)     |
| Current of Power Supply | (a) Black   | -     | 600   | 800    | mA   | (2),(3) |
|                         | (b) White   | -     | 1200  | 1400   | mA   |         |
|                         | (c) Chacker | -     | 800   | 1000   | mA   |         |
| Vsync Frequency         | $f_V$       | 48    | 60.0  | 62     | Hz   |         |
| Hsync Frequency         | $f_H$       | 54    | 67.5  | 69.75  | kHz  |         |
| Main Frequency          | $f_{DCLK}$  | 118.8 | 148.5 | 153.45 | MHz  |         |
| Rush Current            | $I_{RUSH}$  | -     | -     | 3.0    | A    | (4)     |

Note (1) The ripple voltage should be controlled under 10% of  $V_{DD}$ .

(2)  $f_V = 60\text{Hz}$ ,  $f_{DCLK} = 148.5\text{MHz}$ ,  $V_{DD} = 12.0\text{V}$ , DC Current.

(3) Power dissipation check pattern (LCD Module only)

a) Black Pattern

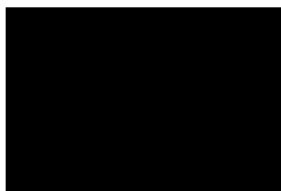

b) White Pattern



c) Chacker

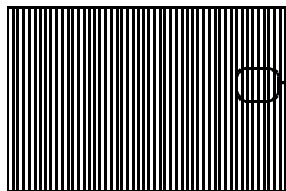

#### (4) Measurement Conditions

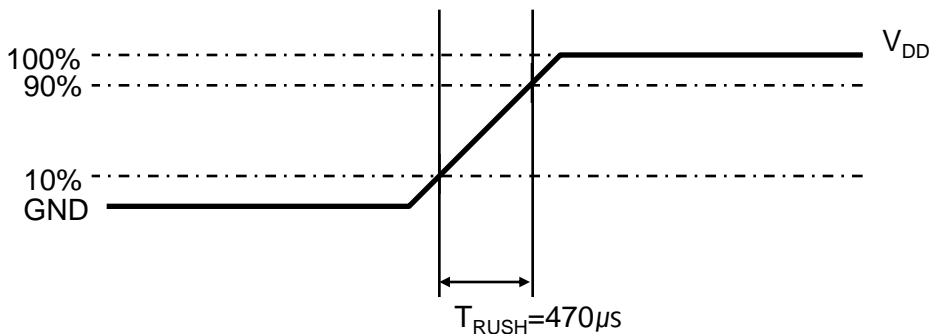

Rush Current  $I_{RUSH}$  can be measured when  $T_{RUSH}$  is  $470\mu\text{s}$ .

### 4.2 Back Light Unit

The backlight unit contains 12 direct-lighting type CCFTs (Cold Cathode Fluorescent Tube). The characteristics of lamps are shown in the following tables.

$T_a=25 \pm 2^\circ\text{C}$

| Item                | Symbol | Min.   | Typ. | Max. | Unit  | Note |
|---------------------|--------|--------|------|------|-------|------|
| Lamp Current        | $I_L$  | 11.0   | 14.0 | 15.0 | mArms |      |
| Lamp Voltage        | $V_L$  | 920    | 950  | 980  | Vrms  |      |
| Operating Life Time | Hr     | 50,000 | -    | -    | Hour  | (1)  |

Note (1) It is defined as the time to take until the brightness reduces to 50% of its original value.

[Operating condition :  $T_a = 25 \pm 2^\circ\text{C}$ ,  $I_L = 14.0$  mArms, For single lamp only]

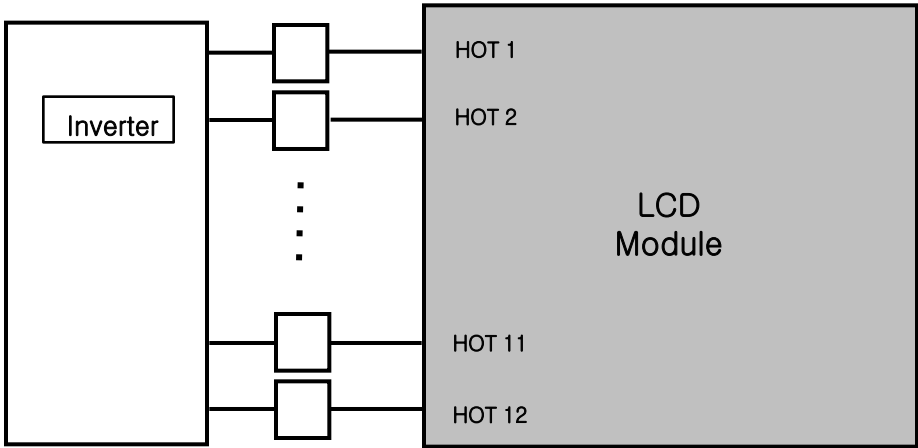

### 4.3 Inverter input condition & Specification

| Items            | Symbol             | Conditions   | Specifications |      |      | Unit  | Note                    |
|------------------|--------------------|--|----------------|------|------|-------|-------------------------|
|                  |                    |  | Min.           | Typ. | Max. |       |                         |
| Input Voltage    | V <sub>in</sub>    | -  | 21.6           | 24   | 26.4 | V     | T <sub>a</sub> =25±2 °C |
| Input Current    | I <sub>in</sub>    | V <sub>in</sub> = 24.0V<br>V <sub>dim</sub> = 3.3V | -              | -    | 9.09 | Adc   | Initial turn on         |
| Lamp Current     | I <sub>O,MAX</sub> | V <sub>dim</sub> = 3.3V                            | 13.3           | 14.0 | 14.7 | mArms | After 1 hour Warm-up(1) |
| Backlight On/Off | ON                 | V <sub>in</sub> = 24.0V                            | 2.4            | -    | 5.25 | V     | -                       |
|                  | OFF                | V <sub>in</sub> = 24.0V                            | 0              | -    | 0.8  |       |                         |
| Dimming Control  | VDim               | Max. Lum   | 3.3            | -    | -    | V     | (2)                     |
|                  |                    | Min. Lum   | -              | -    | 0    |       |                         |

Note (1) Power Consumption is measured at 700[cd/m<sup>2</sup>] of luminance condition which is the typical luminance value.

(2) Internal PWM Dimming

- Analog DC Voltage 0 V : Minimum Duty
- Analog DC Voltage 3.3 V : Maximum Duty

※ Additional Appendix for supply current

| Items         | Symbol                     | Conditions   | Specifications |      |      | Unit |
|---------------|----------------------------|--|----------------|------|------|------|
|               |                            |  | Min.           | Typ. | Max. |      |
| Input Current | I <sub>IN_overshoot</sub>  | V <sub>IN</sub> =24V, DIM=3.3V<br>(Within 1hr at BLU ON) | -              | 7.78 | 8.30 | Adc  |
|               | I <sub>IN_saturation</sub> | V <sub>IN</sub> =24V, DIM=3.3V<br>(After 1hr Aging)      | -              | 6.75 | 7.20 |      |

## 5. Input Terminal Pin Assignment

### 5.1 Input Signal & Power

Connector : FI-RE51S-HF (JAE)

| PIN No. | Description           |        | PIN No.          | Description            |                   |
|---------|-----------------------|--------|------------------|------------------------|-------------------|
| 1       | Vdd (12V)             |        | 26               | Even<br>LVDS<br>Signal | RE[0]P            |
| 2       | Vdd (12V)             |        | 27               |                        | RE[1]N            |
| 3       | Vdd (12V)             |        | 28               |                        | RE[1]P            |
| 4       | Vdd (12V)             |        | 29               |                        | RE[2]N            |
| 5       | Vdd (12V)             |        | 30               |                        | RE[2]P            |
| 6       | No Connection(1)      |        | 31               |                        | GND               |
| 7       | GND                   |        | 32               |                        | RECLK-            |
| 8       | GND                   |        | 33               |                        | RECLK+            |
| 9       | GND                   |        | 34               |                        | GND               |
| 10      | Odd<br>LVDS<br>Signal | RO[0]N | 35               |                        | RE[3]N            |
| 11      |                       | RO[0]P | 36               |                        | RE[3]P            |
| 12      |                       | RO[1]N | 37               |                        | No Connection(1)  |
| 13      |                       | RO[1]P | 38               |                        | No Connection(1)  |
| 14      |                       | RO[2]N | 39               |                        | GND               |
| 15      |                       | RO[2]P | 40               |                        | No Connection (1) |
| 16      |                       | GND    | 41               |                        | No Connection(1)  |
| 17      |                       | ROCLK- | 42               |                        | No Connection (1) |
| 18      |                       | ROCLK+ | 43               |                        | No Connection(1)  |
| 19      |                       | GND    | 44               | No Connection (1)      |                   |
| 20      |                       | RO[3]N | 45               | LVDS_SEL (2)           |                   |
| 21      |                       | RO[3]P | 46               | No Connection(1)       |                   |
| 22      | No Connection(1)      | 47     | No Connection(1) |                        |                   |
| 23      | No Connection(1)      | 48     | No Connection(1) |                        |                   |
| 24      | GND                   |        | 49               | No Connection (1)      |                   |
| 25      | Even LVDS             | RE[0]N | 50               | No Connection(1)       |                   |
|         |                       |        | 51               | No Connection (1)      |                   |

Note 1) No Connection : These pins are only used for SAMSUNG internal purpose.

Note 2) LVDS OPTION : IF THIS PIN : HIGH (3.3 V) → NORMAL NS LVDS FORMAT

OTHERWISE : LOW (GND) OR OPEN(NC) → JEIDA LVDS FORMAT

Sequence : On =  $V_{DD}(T1) \geq LVDS\ Option \geq Interface\ Signal(T2)$

OFF =  $Interface\ Signal(T3) \geq LVDS\ Option \geq V_{DD}$

Note (3) LVDS Connector

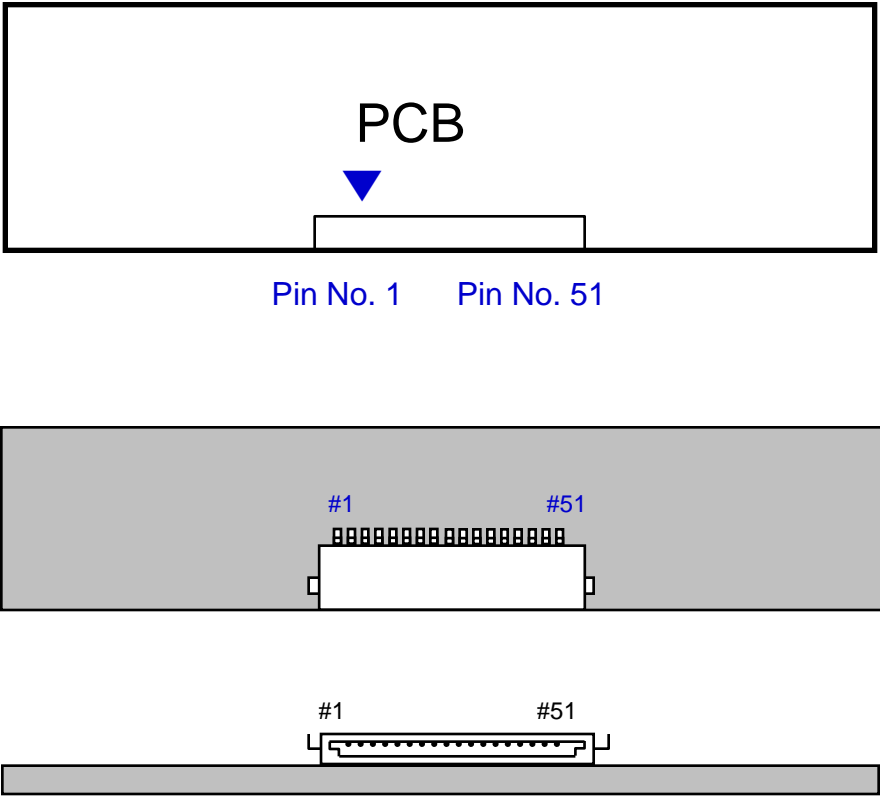

Fig. Connector diagram

- a. All GND pins should be connected together and also be connected to the LCD's metal chassis.
- b. All power input pins should be connected together.
- c. All N.C pins should be separated from other signal or power.

5.2 Inverter input Pin Configuration

22022WR-014B1 (YEONHO)

| Pin No. | Pin Configuration(FUNCTION)  |
|---------|--|
| 1       | Vin (24V)  |
| 2       | Vin (24V)  |
| 3       | Vin (24V)  |
| 4       | Vin (24V)  |
| 5       | Vin (24V)  |
| 6       | GND  |
| 7       | GND  |
| 8       | GND  |
| 9       | GND  |
| 10      | GND  |
| 11      | No Connection  |
| 12      | ENA (Inverter on/off Control signal)<br>DC 0 to 0.8V off, DC 2.4 to 5.25V On |
| 13      | Internal Dimming control [0V: Min, 3.3V: Max]                                |
| 14      | No Connection  |

5.3 Inverter Input Power Sequence

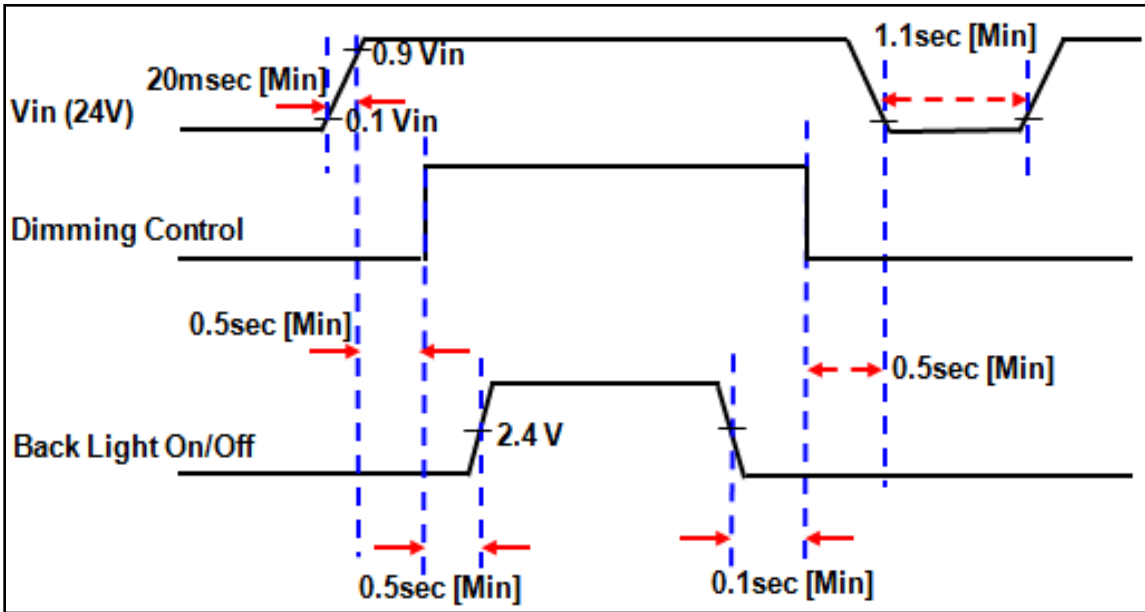

5.4 LVDS Interface

- LVDS Receiver : Tcon (merged)
- Data Format (JEIDA & Normal)

Default LVDS Option : JEIDA

|             | LVDS pin     | JEIDA -DATA | VESA -DATA |
|-------------|--------------|-------------|------------|
| TxOUT/RxIN0 | TxIN/RxOUT0  | R2          | R0         |
|             | TxIN/RxOUT1  | R3          | R1         |
|             | TxIN/RxOUT2  | R4          | R2         |
|             | TxIN/RxOUT3  | R5          | R3         |
|             | TxIN/RxOUT4  | R6          | R4         |
|             | TxIN/RxOUT6  | R7          | R5         |
|             | TxIN/RxOUT7  | G2          | G0         |
| TxOUT/RxIN1 | TxIN/RxOUT8  | G3          | G1         |
|             | TxIN/RxOUT9  | G4          | G2         |
|             | TxIN/RxOUT12 | G5          | G3         |
|             | TxIN/RxOUT13 | G6          | G4         |
|             | TxIN/RxOUT14 | G7          | G5         |
|             | TxIN/RxOUT15 | B2          | B0         |
|             | TxIN/RxOUT18 | B3          | B1         |
| TxOUT/RxIN2 | TxIN/RxOUT19 | B4          | B2         |
|             | TxIN/RxOUT20 | B5          | B3         |
|             | TxIN/RxOUT21 | B6          | B4         |
|             | TxIN/RxOUT22 | B7          | B5         |
|             | TxIN/RxOUT24 | HSYNC       | HSYNC      |
|             | TxIN/RxOUT25 | VSYNC       | VSYNC      |
|             | TxIN/RxOUT26 | DEN         | DEN        |
| TxOUT/RxIN3 | TxIN/RxOUT27 | R0          | R6         |
|             | TxIN/RxOUT5  | R1          | R7         |
|             | TxIN/RxOUT10 | G0          | G6         |
|             | TxIN/RxOUT11 | G1          | G7         |
|             | TxIN/RxOUT16 | B0          | B6         |
|             | TxIN/RxOUT17 | B1          | B7         |
|             | TxIN/RxOUT23 | RESERVED    | RESERVED   |



5.5 Input Signals, Basic Display Colors and Gray Scale of Each Color

| COLOR               | DISPLAY (8bit) | DATA SIGNAL |    |    |    |    |    |    |       |    |    |    |    |    |    |      |    |    |    |    |    |    |    |      |         | GRAY SCALE LEVEL |
|---------------------|----------------|-------------|----|----|----|----|----|----|-------|----|----|----|----|----|----|------|----|----|----|----|----|----|----|------|---------|------------------|
|                     |                | RED         |    |    |    |    |    |    | GREEN |    |    |    |    |    |    | BLUE |    |    |    |    |    |    |    |      |         |                  |
|                     |                | R0          | R1 | R2 | R3 | R4 | R5 | R6 | R7    | G0 | G1 | G2 | G3 | G4 | G5 | G6   | G7 | B0 | B1 | B2 | B3 | B4 | B5 | B6   | B7      |                  |
| BASIC COLOR         | BLACK          | 0           | 0  | 0  | 0  | 0  | 0  | 0  | 0     | 0  | 0  | 0  | 0  | 0  | 0  | 0    | 0  | 0  | 0  | 0  | 0  | 0  | 0  | 0    | 0       | -                |
|                     | BLUE           | 0           | 0  | 0  | 0  | 0  | 0  | 0  | 0     | 0  | 0  | 0  | 0  | 0  | 0  | 0    | 0  | 1  | 1  | 1  | 1  | 1  | 1  | 1    | 1       | -                |
|                     | GREEN          | 0           | 0  | 0  | 0  | 0  | 0  | 0  | 0     | 1  | 1  | 1  | 1  | 1  | 1  | 1    | 1  | 0  | 0  | 0  | 0  | 0  | 0  | 0    | 0       | -                |
|                     | CYAN           | 0           | 0  | 0  | 0  | 0  | 0  | 0  | 0     | 1  | 1  | 1  | 1  | 1  | 1  | 1    | 1  | 1  | 1  | 1  | 1  | 1  | 1  | 1    | 1       | -                |
|                     | RED            | 1           | 1  | 1  | 1  | 1  | 1  | 1  | 1     | 0  | 0  | 0  | 0  | 0  | 0  | 0    | 0  | 0  | 0  | 0  | 0  | 0  | 0  | 0    | 0       | -                |
|                     | MAGENTA        | 1           | 1  | 1  | 1  | 1  | 1  | 1  | 1     | 0  | 0  | 0  | 0  | 0  | 0  | 0    | 0  | 1  | 1  | 1  | 1  | 1  | 1  | 1    | 1       | -                |
|                     | YELLOW         | 1           | 1  | 1  | 1  | 1  | 1  | 1  | 1     | 1  | 1  | 1  | 1  | 1  | 1  | 1    | 1  | 0  | 0  | 0  | 0  | 0  | 0  | 0    | 0       | -                |
|                     | WHITE          | 1           | 1  | 1  | 1  | 1  | 1  | 1  | 1     | 1  | 1  | 1  | 1  | 1  | 1  | 1    | 1  | 1  | 1  | 1  | 1  | 1  | 1  | 1    | 1       | -                |
| GRAY SCALE OF RED   | BLACK          | 0           | 0  | 0  | 0  | 0  | 0  | 0  | 0     | 0  | 0  | 0  | 0  | 0  | 0  | 0    | 0  | 0  | 0  | 0  | 0  | 0  | 0  | 0    | R0      |                  |
|                     | DARK ↑         | 1           | 0  | 0  | 0  | 0  | 0  | 0  | 0     | 0  | 0  | 0  | 0  | 0  | 0  | 0    | 0  | 0  | 0  | 0  | 0  | 0  | 0  | 0    | R1      |                  |
|                     |                | 0           | 1  | 0  | 0  | 0  | 0  | 0  | 0     | 0  | 0  | 0  | 0  | 0  | 0  | 0    | 0  | 0  | 0  | 0  | 0  | 0  | 0  | 0    | R2      |                  |
|                     |                | :           | :  | :  | :  | :  | :  | :  | :     | :  | :  | :  | :  | :  | :  | :    | :  | :  | :  | :  | :  | :  | :  | :    | :       | R3~R252          |
|                     | ↓ LIGHT        | :           | :  | :  | :  | :  | :  | :  | :     | :  | :  | :  | :  | :  | :  | :    | :  | :  | :  | :  | :  | :  | :  | :    | :       |                  |
|                     |                | 1           | 0  | 1  | 1  | 1  | 1  | 1  | 1     | 0  | 0  | 0  | 0  | 0  | 0  | 0    | 0  | 0  | 0  | 0  | 0  | 0  | 0  | 0    | R253    |                  |
|                     | 0              | 1           | 1  | 1  | 1  | 1  | 1  | 1  | 1     | 0  | 0  | 0  | 0  | 0  | 0  | 0    | 0  | 0  | 0  | 0  | 0  | 0  | 0  | 0    | R254    |                  |
| RED                 | 1              | 1           | 1  | 1  | 1  | 1  | 1  | 1  | 0     | 0  | 0  | 0  | 0  | 0  | 0  | 0    | 0  | 0  | 0  | 0  | 0  | 0  | 0  | R255 |         |                  |
| GRAY SCALE OF GREEN | BLACK          | 0           | 0  | 0  | 0  | 0  | 0  | 0  | 0     | 0  | 0  | 0  | 0  | 0  | 0  | 0    | 0  | 0  | 0  | 0  | 0  | 0  | 0  | 0    | G0      |                  |
|                     | DARK ↑         | 0           | 0  | 0  | 0  | 0  | 0  | 0  | 0     | 1  | 0  | 0  | 0  | 0  | 0  | 0    | 0  | 0  | 0  | 0  | 0  | 0  | 0  | 0    | G1      |                  |
|                     |                | 0           | 0  | 0  | 0  | 0  | 0  | 0  | 0     | 0  | 1  | 0  | 0  | 0  | 0  | 0    | 0  | 0  | 0  | 0  | 0  | 0  | 0  | 0    | G2      |                  |
|                     |                | :           | :  | :  | :  | :  | :  | :  | :     | :  | :  | :  | :  | :  | :  | :    | :  | :  | :  | :  | :  | :  | :  | :    | G3~G252 |                  |
|                     | ↓ LIGHT        | :           | :  | :  | :  | :  | :  | :  | :     | :  | :  | :  | :  | :  | :  | :    | :  | :  | :  | :  | :  | :  | :  | :    |         |                  |
|                     |                | 0           | 0  | 0  | 0  | 0  | 0  | 0  | 0     | 1  | 0  | 1  | 1  | 1  | 1  | 1    | 1  | 0  | 0  | 0  | 0  | 0  | 0  | 0    | G253    |                  |
|                     | 0              | 0           | 0  | 0  | 0  | 0  | 0  | 0  | 0     | 0  | 1  | 1  | 1  | 1  | 1  | 1    | 1  | 0  | 0  | 0  | 0  | 0  | 0  | 0    | G254    |                  |
| GREEN               | 0              | 0           | 0  | 0  | 0  | 0  | 0  | 0  | 1     | 1  | 1  | 1  | 1  | 1  | 1  | 1    | 0  | 0  | 0  | 0  | 0  | 0  | 0  | G255 |         |                  |
| GRAY SCALE OF BLUE  | BLACK          | 0           | 0  | 0  | 0  | 0  | 0  | 0  | 0     | 0  | 0  | 0  | 0  | 0  | 0  | 0    | 0  | 0  | 0  | 0  | 0  | 0  | 0  | 0    | B0      |                  |
|                     | DARK ↑         | 0           | 0  | 0  | 0  | 0  | 0  | 0  | 0     | 0  | 0  | 0  | 0  | 0  | 0  | 0    | 0  | 1  | 0  | 0  | 0  | 0  | 0  | 0    | B1      |                  |
|                     |                | 0           | 0  | 0  | 0  | 0  | 0  | 0  | 0     | 0  | 0  | 0  | 0  | 0  | 0  | 0    | 0  | 0  | 1  | 0  | 0  | 0  | 0  | 0    | B2      |                  |
|                     |                | :           | :  | :  | :  | :  | :  | :  | :     | :  | :  | :  | :  | :  | :  | :    | :  | :  | :  | :  | :  | :  | :  | :    | B3~B252 |                  |
|                     | ↓ LIGHT        | :           | :  | :  | :  | :  | :  | :  | :     | :  | :  | :  | :  | :  | :  | :    | :  | :  | :  | :  | :  | :  | :  | :    |         |                  |
|                     |                | 0           | 0  | 0  | 0  | 0  | 0  | 0  | 0     | 0  | 0  | 0  | 0  | 0  | 0  | 0    | 0  | 1  | 0  | 1  | 1  | 1  | 1  | 1    | B253    |                  |
|                     | 0              | 0           | 0  | 0  | 0  | 0  | 0  | 0  | 0     | 0  | 0  | 0  | 0  | 0  | 0  | 0    | 0  | 0  | 1  | 1  | 1  | 1  | 1  | 1    | B254    |                  |
| BLUE                | 0              | 0           | 0  | 0  | 0  | 0  | 0  | 0  | 0     | 0  | 0  | 0  | 0  | 0  | 0  | 0    | 1  | 1  | 1  | 1  | 1  | 1  | 1  | B255 |         |                  |

Note) Definition of Gray :  
 Rn : Red Gray, Gn : Green Gray, Bn : Blue Gray (n = Gray level)  
 Input Signal : 0 = Low level voltage, 1 = High level voltage

## 6. Interface Timing

### 6.1 Timing Parameters (DE mode)

| Signal                  | Item                  | Symbol   | Min. | Typ.  | Max. | Unit   | Note |
|-------------------------|-----------------------|----------|------|-------|------|--------|------|
| Clock                   | Frequency             | $1/T_C$  | 130  | 148.5 | 160  | MHz    | -    |
| Hsync                   |                       | $F_H$    | 48.0 | 67.5  | 72.0 | KHz    | -    |
| Vsync                   |                       | $F_V$    | 45   | 60    | 65   | Hz     | -    |
| Vertical Display Term   | Active Display Period | $T_{VD}$ | -    | 1080  | -    | Lines  | -    |
|                         | Vertical Total        | $T_V$    | 1092 | 1125  | 1158 | Lines  | -    |
| Horizontal Display Term | Active Display Period | $T_{HD}$ | -    | 1920  | -    | Clocks | -    |
|                         | Horizontal Total      | $T_H$    | 2090 | 2200  | 2350 | Clocks | -    |

Note) This product is DE mode. And, the input of Hsync & Vsync signal does not have an effect on normal operation.

Test Point : TTL control signal and CLK at LVDS Tx input terminal in system

6.2 Timing diagrams of interface signal (DE mode)

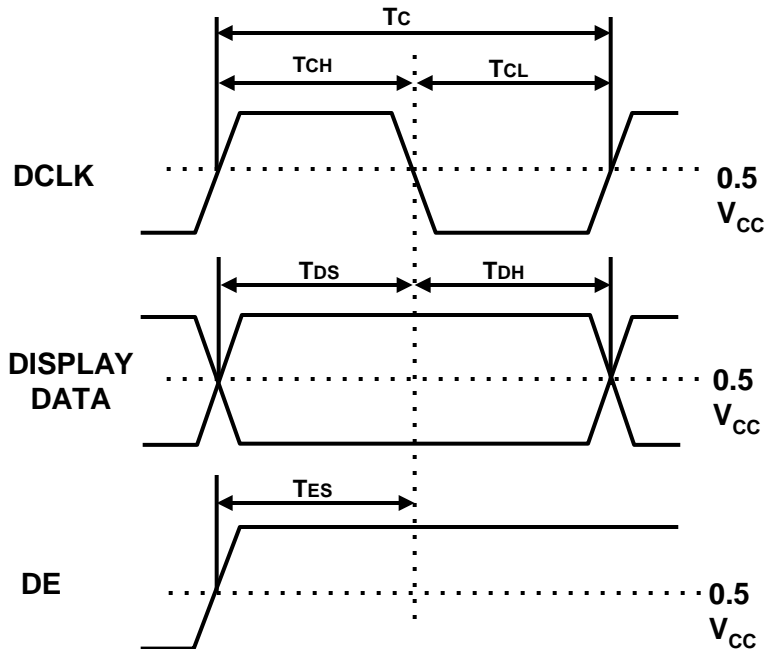
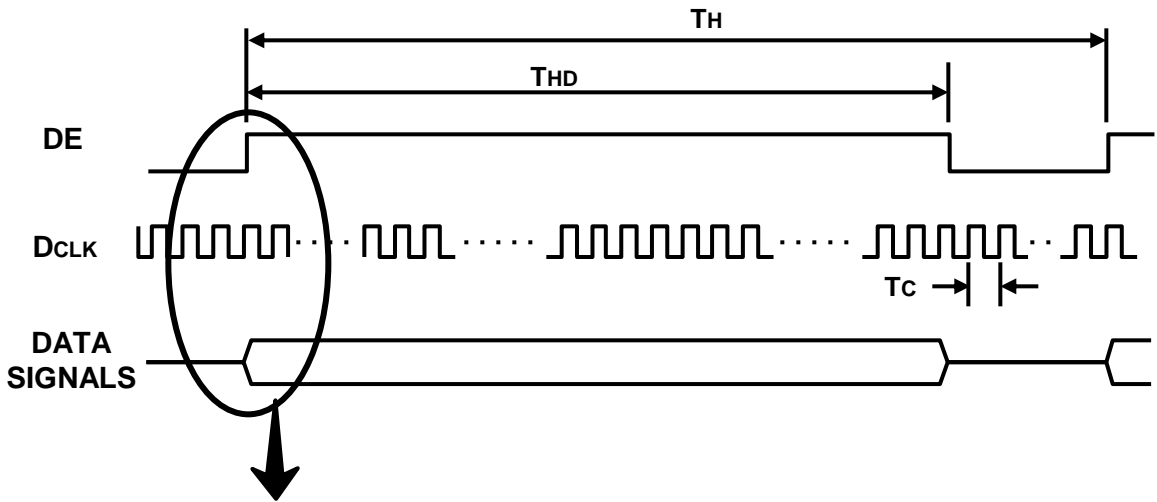
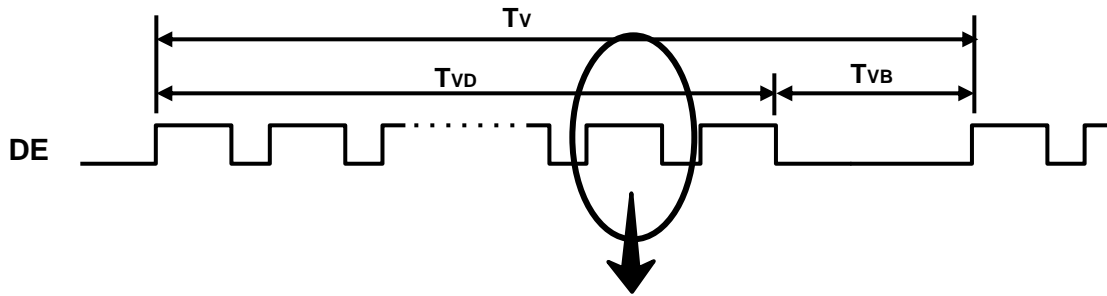

### 6.3 Power ON/OFF Sequence

To prevent a latch-up or DC operation of the LCD Module, the power on/off sequence should be as the diagram below.

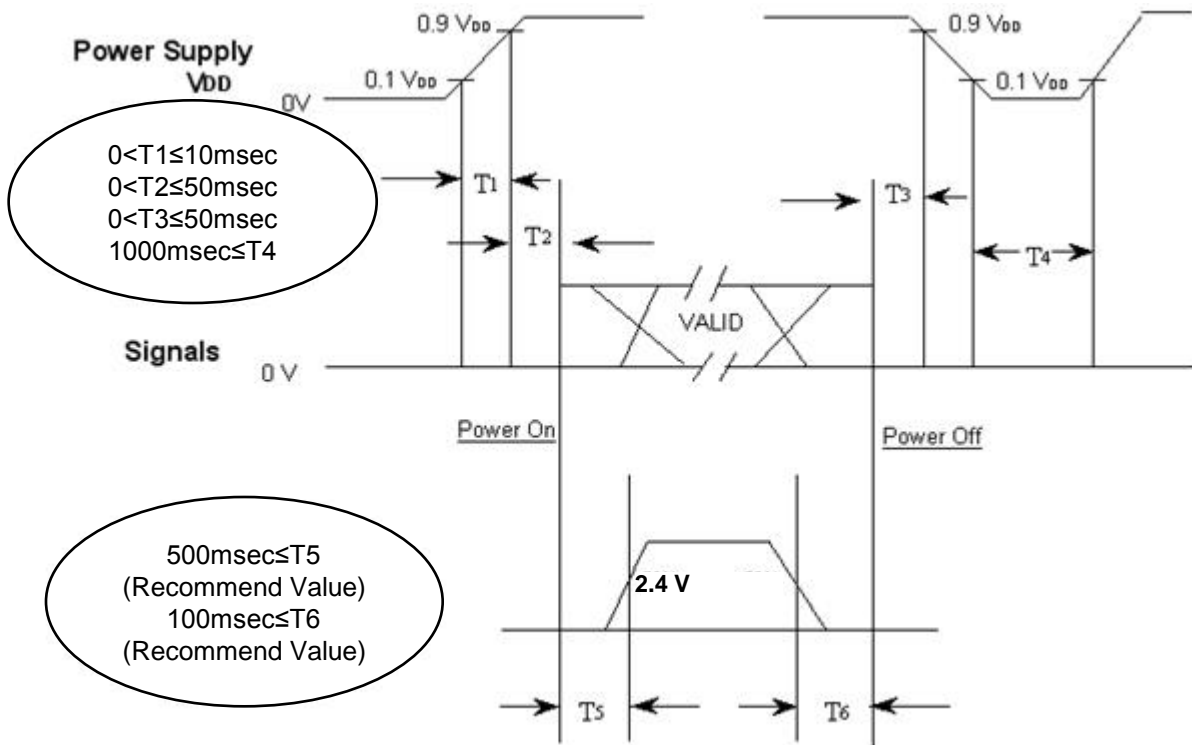

- T1 : V<sub>DD</sub> rising time from 10% to 90%
- T2 : The time from V<sub>DD</sub> to valid data at power ON.
- T3 : The time from valid data off to V<sub>DD</sub> off at power Off.
- T4 : V<sub>DD</sub> off time for Windows restart
- T5 : The time from valid data to B/L enable at power ON.
- T6 : The time from valid data off to B/L disable at power Off.

- The supply voltage of the external system for the Module input should be the same as the definition of V<sub>DD</sub>.
- Apply the lamp voltage within the LCD operation range. When the backlight turns on before the LCD operation or the LCD turns off before the backlight turns off, the display may momentarily show abnormal screen.
- In case of V<sub>DD</sub> = off level, please keep the level of input signals low or keep a high impedance.
- T4 should be measured after the Module has been fully discharged between power off and on period.
- Interface signal should not be kept at high impedance when the power is on.

# 7. Outline Dimension (Front View)

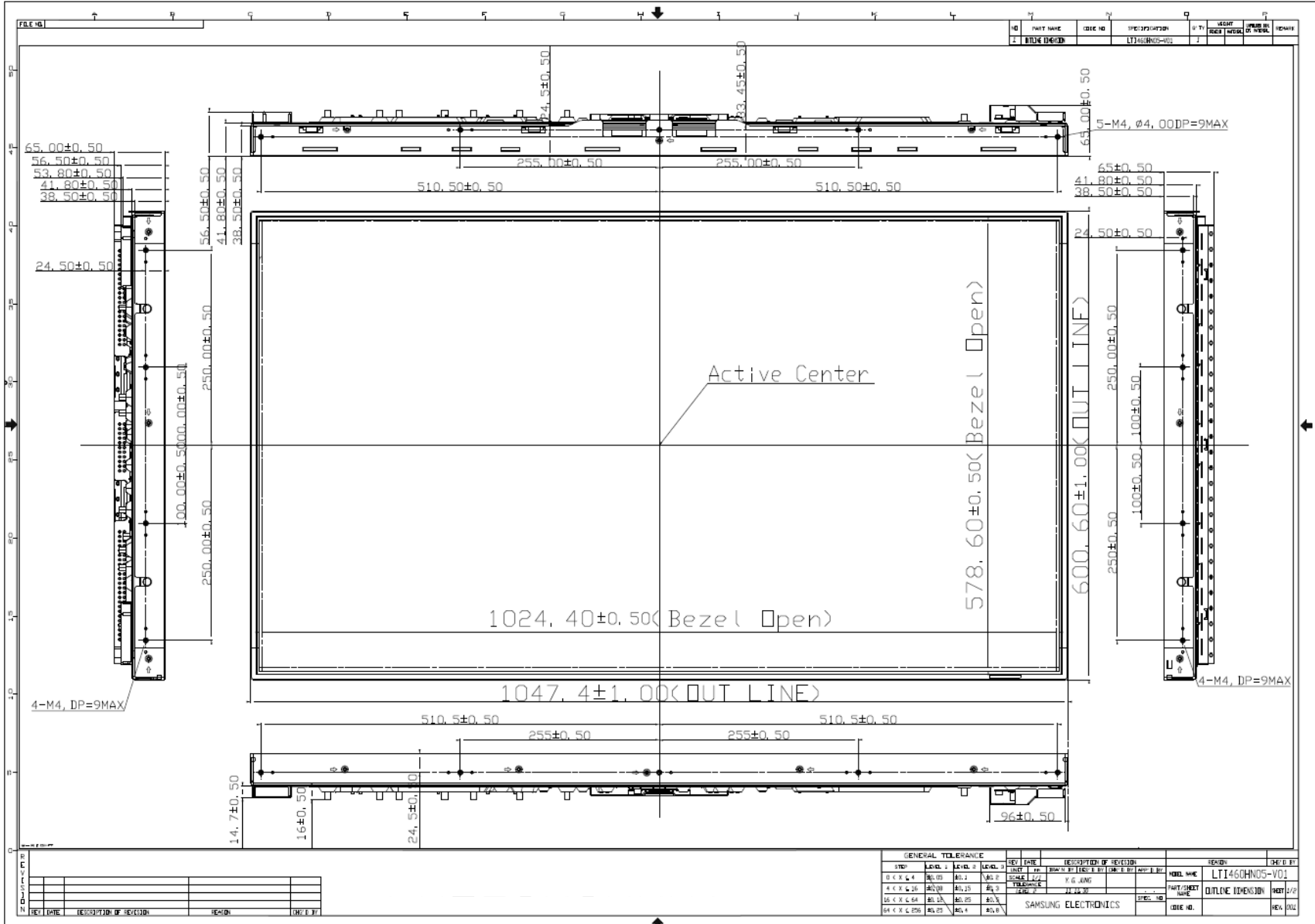

# 7. Outline Dimension (Rear View)

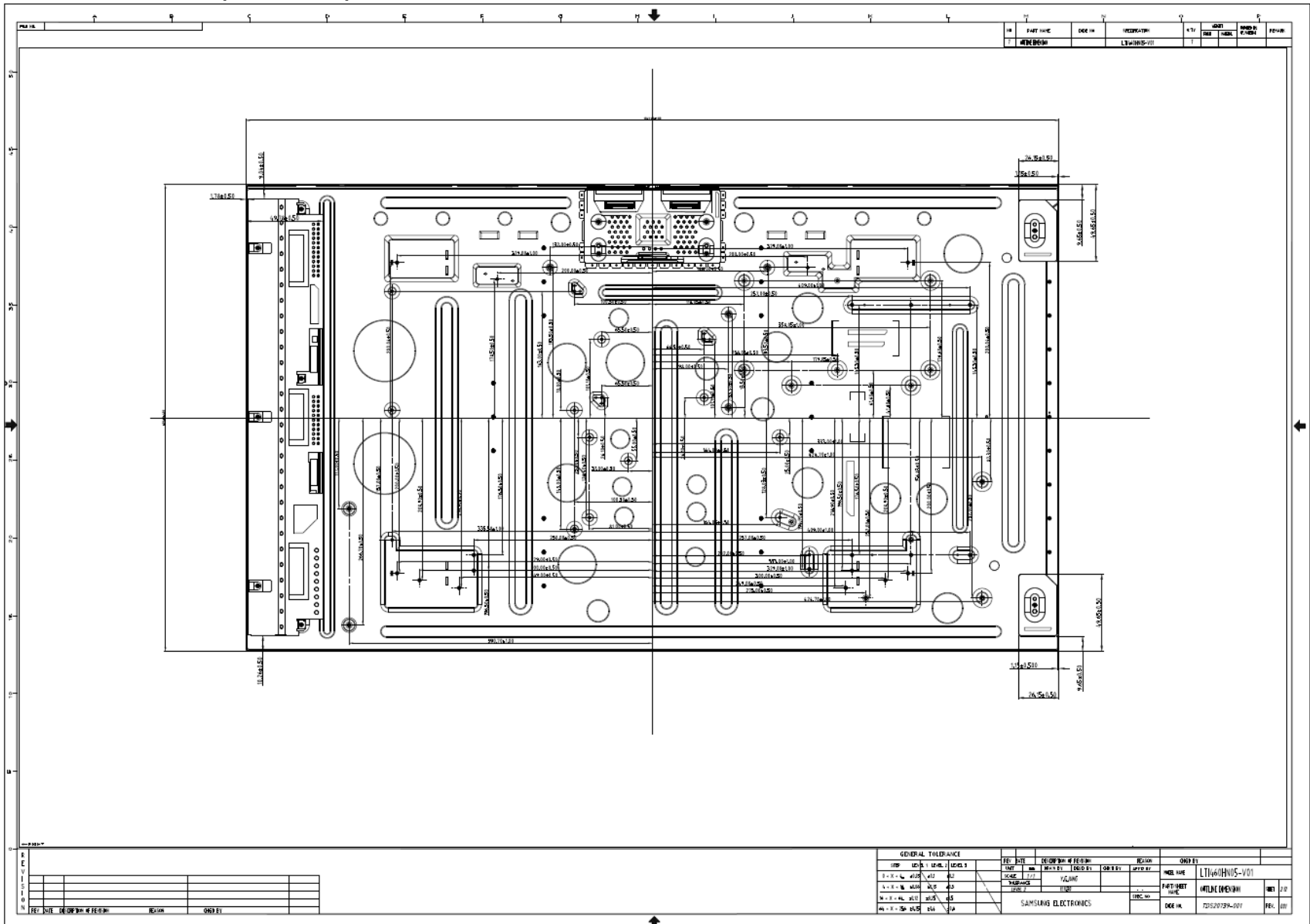

## 8. Reliability Test

| Item                              | Test condition  | Quantity |
|-----------------------------------|---|----------|
| HTOL                              | 50℃, 500hr determination  | 8EA      |
| LTOL                              | 0℃, 500hr determination   | 4EA      |
| HTS                               | 70℃, 500hr determination  | 4EA      |
| LTS                               | -25℃, 500hr determination   | 4EA      |
| THB                               | 50℃ / 80%RH, 500hr determination  | 4EA      |
| WHTS                              | 60℃ / 75%RH, 500hr determination  | 4EA      |
| T/S                               | -20 ~ 60℃, Dwell time : 30Min, 100cycle   | 4EA      |
| TSS                               | -20 ~ 65℃, 220cycle   | 4EA      |
| Image sticking                    | 50℃, Mosaic pattern (9X10), 168hrs  | 4EA      |
| Contact ESD                       | ± 10 kV , 150pF/330Ω, 210Point, 1 time/Point  | 3EA      |
| Air ESD                           | ± 20 kV, 150pF/100Ω, 210Point, 1 time/Point   | 3EA      |
| Input Con. ESD                    | ± 15kV, 150pF/330Ω, Input Con. Pin, 3 times/Pin   | 3EA      |
| Vibration                         | 10 ~ 300Hz, 1.5G, 10minSR, 30min/± XYZ axis   | 3EA      |
| Shock                             | 1time/± XY axis, 30G, 11msec  | 3EA      |
| Dust                              | JIS 8types(6.6 ~ 8.6um), Carbon black(20nm) 4g, 5sec spray, 5min sedimentation / 10hr, Power 10min on, 10min off  | 2EA      |
| Pallet Vibration<br>→ Pallet Drop | Pallet vibration : 1.05Grms, 5 ~ 200Hz, 2hr/stack side<br>Pallet Drop : 20cm, bottom side 2 angles, 1side(Bottom) | 1Pallet  |
| Altitude                          | -40~50℃, 0m(0ft)~13,700m(45,000ft), 72.5Hr  | 4EA      |
| Twist                             | 10°, 0.7s/times, 1000times  | 4EA      |

### [ Result Evaluation Criteria]

Under the display quality test conditions with normal operation state, these should be no change which may affect practical display functions.

- \* HTOL/ LTOL : High/Low Temperature Operating Life
- \*\* THB : Temperature Humidity Bias
- \*\*\* HTS/LTS : High/Low Temperature Storage
- \*\*\*\* WHTS : Wet High Temperature Storage

## 9. PACKING

### 9.1 CARTON (Internal Package)

- (1) Packing Form  
Corrugated fiberboard box and corrugated cardboard as shock absorber
- (2) Packing Method

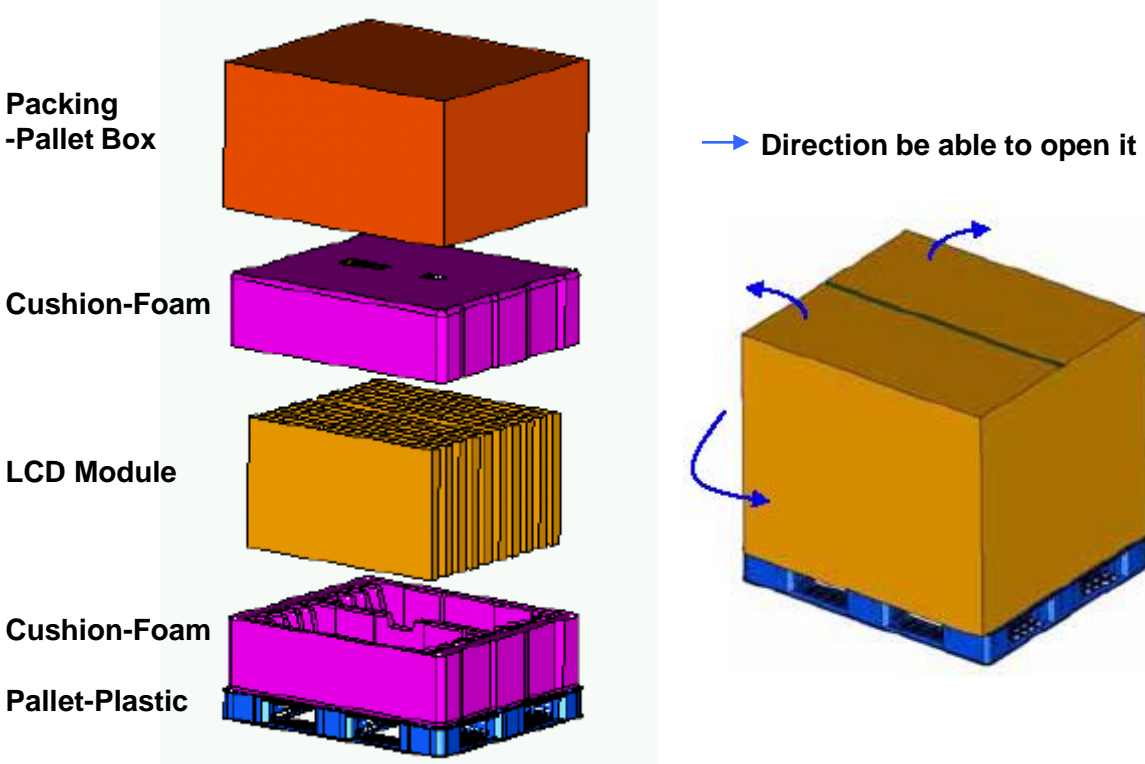

### 9.2 Packing Specification

| Item                | Specification               | Remark  |
|---------------------|-----------------------------|---|
| LCD Packing         | 10ea / (Packing-Pallet Box) | 1. 135 Kg / LCD (10ea)<br>2. 10 Kg / Cushion-pallet (2ea)<br>3. 8 Kg / Packing-Pallet Box (1ea)<br>4. Cushion-pallet Material : EPS<br>5. Packing-Pallet Box Material : DW4 |
| Pallet              | 1Box / Pallet               | 1. Pallet weight = 8.8kg  |
| Packing Direction   | Vertical                    |   |
| Total Pallet Size   | H x V x height              | 1270mm(H) x 1150mm(V) x 844mm(height)   |
| Total Pallet Weight | 161.8 kg                    | Pallet(8.8kg) + Module(135 kg) + Cushion(10kg) + Pallet-BOX(8kg)  |



9.3 Packing Storage condition

| ITEM                | Unit   | Min. | Max. |
|---------------------|--|------|------|
| Storage Temperature | ( °C )   | 5    | 40   |
| Storage Humidity    | (%rH)  | 35   | 75   |
| Storage life        | 12 months  |      |      |
| Storage Condition   | <ul style="list-style-type: none"> <li>- The storage room should provide good ventilation and temperature control.</li> <li>- Products should not be placed on the floor, but on the Pallet away from a wall.</li> <li>- Prevent products from direct sunlight, moisture nor water; Be cautious of a build up of condensation.</li> <li>- Avoid other hazardous environment while storing goods.</li> <li>- If products delivered or kept in conditions of over the storage period of 3 months, the recommended temperature or humidity range, we recommend you leave them at a temperature of 20°C and a humidity of 50% for 24 hours.</li> </ul> |      |      |

9.4 Packing long-term Storage guide

|                            |  |
|----------------------------|--|
| Long –term Storage Process | More than 3months Storage or Low temp.<br>Delivery/under 5°C Storage → On the 20°C 50%rH Condition, More than 10hrs release. |
|----------------------------|--|

# 10. MARKING & OTHERS

A nameplate bearing followed by is affixed to a shipped product at the specified location on each product.

- (1) Part number : LTI460HN05
- (2) Revision: Three letters
- (3) Lot number : X X X X XXX XX X

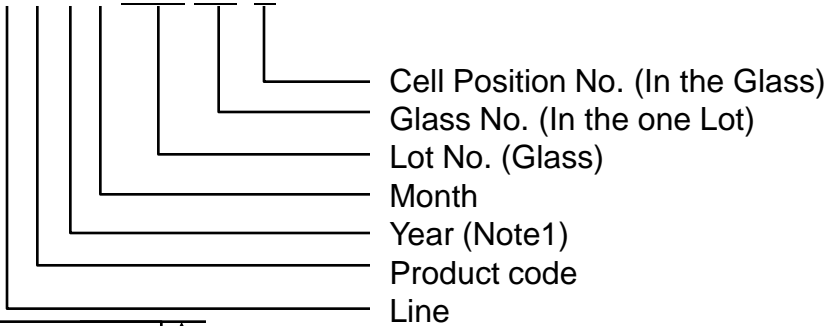

## (4) Nameplate Indication

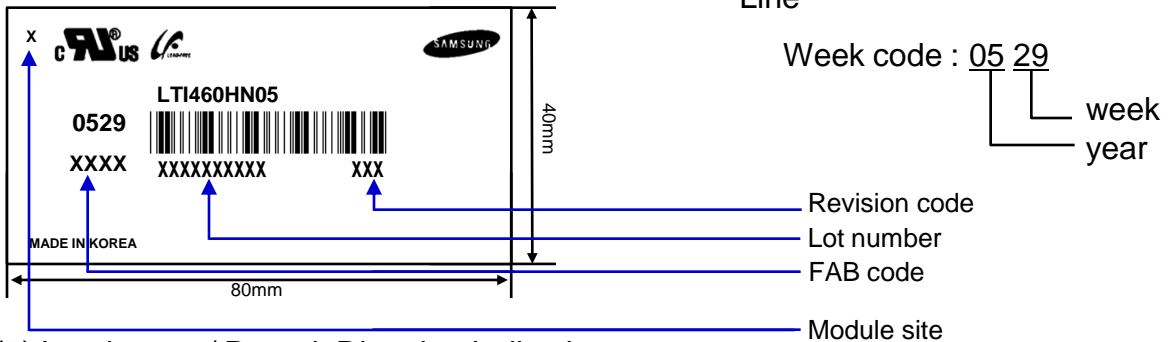

## (5) Landscape / Portrait Direction Indication

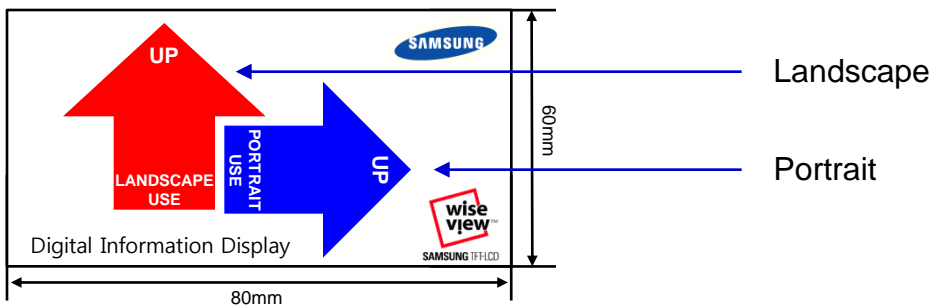

## (6) Packing box attach

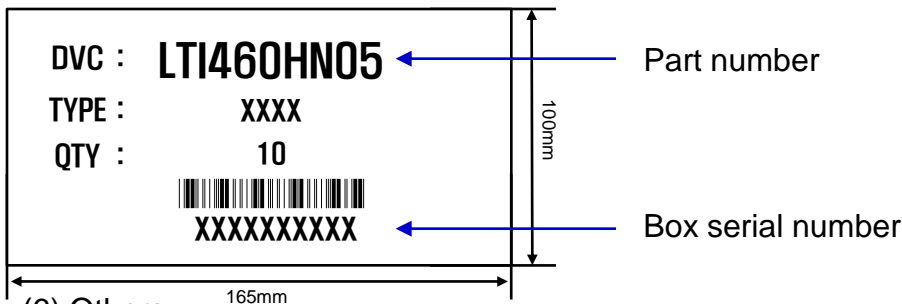

## (6) Others

- 1. After service part  
 Lamps cannot be replaced because of the narrow bezel structure.

## 11. General Precautions

### 11.1 Handling

- (a) When the Module is assembled, it should be attached to the system firmly using all mounting holes. Be careful not to twist and bend the Module.
- (b) Because the inverter use high voltage, it should be disconnected from power before it is assembled or disassembled.
- (c) Refrain from strong mechanical shock and / or any force to the Module.  
In addition to damage, this may cause improper operation or damage to the Module and CCFT back light.
- (d) Note that polarizers are very fragile and could be damage easily.  
Do not press or scratch the surface harder than a HB pencil lead.
- (e) Wipe off water droplets or oil immediately. If you leave the droplets for a long time, staining or discoloration may occur.
- (f) If the surface of the polarizer is dirty, clean it using absorbent cotton or soft cloth.
- (g) Desirable cleaners are water, IPA(Isopropyl Alcohol) or Hexane.  
Do not use Ketone type materials(ex. Acetone), Ethyl alcohol, Toluene, Ethyl acid or Methyl chloride. It might permanent damage to the polarizer due to chemical reaction.
- (h) If the liquid crystal material leaks from the panel, it should be kept away from the eyes or mouth . In case of contact with hands, legs or clothes, it must be washed away with soap thoroughly.
- (i) Protect the module from Electrostatic discharge. Otherwise the ASIC IC or semiconductor would be damaged.
- (j) Use finger-stalls with soft gloves in order to keep display clean during the incoming inspection and assembly process.
- (k) Do not disassemble the Module.
- (l) Do not disassemble shield case of inverter & LVDS board
- (m) Do not connect N.C pins. (Samsung internal use only)
- (n) Protection film for polarizer on the Module should be slowly peeled off just before use so that the electrostatic charge can be minimized. Must put on antistatic glove while handling a module
- (o) Pins of I/F connector should not be touched directly with bare hands.

## 11.2 Storage

- (a) Do not leave the Module in high temperature, and high humidity for a long time. It is highly recommended to store the Module with temperature from 0 to 35 °C and relative humidity of less than 70%.
- (b) Do not store the TFT-LCD Module in direct sunlight.
- (c) The Module should be stored in a dark place. It is prohibited to apply sunlight or fluorescent light in storing.

## 11.3 Operation

- (a) Do not connect or disconnect the Module in the "Power On" condition.
- (b) Power supply should always be turned on/off by the "Power on/off sequence"
- (c) Module has high frequency circuits. Sufficient suppression to the electromagnetic interference should be done by system manufacturers.  
Grounding and shielding methods may be important to minimize the interference.
- (d) The cable between the backlight connector and its inverter power supply should be connected directly with a minimized length. A longer cable between the backlight and the inverter may cause lower luminance of lamp(CCFT) and may require higher startup voltage(Vs).

## 11.4 Operation Condition Guide

- (a) The LCD product should be operated under normal conditions.  
Normal condition is defined as below;
  - Temperature :  $20 \pm 15^{\circ}\text{C}$
  - Humidity :  $55 \pm 20\%$
  - Display pattern : continually changing pattern (Not stationary)
- (b) If the product will be used in extreme conditions such as high temperature, humidity, display patterns or operation time etc., It is strongly recommended to contact SEC for Application engineering advice. Otherwise, its reliability and function may not be guaranteed. Extreme conditions are commonly found at Airports, Transit Stations, Banks, Stock market, and Controlling systems.

- (a) Ultra-violet ray filter is necessary for outdoor operation.
- (b) Module should be turned clockwise (regular front view perspective) when used in portrait mode
- (c) Avoid condensation of water. It may result in improper operation or disconnection of electrode.
- (d) Do not exceed the absolute maximum rating value. (supply voltage variation, input voltage variation, variation in part contents and environmental temperature, and so on)  
Otherwise the Module may be damaged.
- (e) If the Module keeps displaying the same pattern for a long period of time, the image may be "sticked" to the screen.  
To avoid image sticking, it is recommended to use a screen saver.
- (f) This Module has its circuitry PCB's on the rear side and should be handled carefully in order not to be stressed.
- (g) Please contact SEC in advance when you display the same pattern for a long time.