

**All information is subject to change without notice. Please read bottom notes.**

- FEATURES:** (1)8.4" SVGA color display with High Brightness (400cd/m<sup>2</sup>).  
 (2)Wide viewing angle and wide operating temperature.  
 (3)Built in Long Life LEDs (MTBF:70,000 h).  
 (Conditions / Ta:25°C, PWM=100%(continuing lighting))  
 (4)Replaceable structure of LED units.  
 (5) Mounting compatible with LTM08C351 series and LTA084C270F.

**TENTATIVE****RoHS compatible****MECHANICAL SPECIFICATIONS**

Item	Specifications
Dimensional Outline (Typ.)	199.5 (W) x 149.5 (H) x 12.0max (D) mm
Number of Pixels	800 (W) x 600 (H) pixels
Active Area	170.4 (W) x 127.8 (H) mm
Pixel Pitch	0.213 (W) x 0.213 (H)
Weight (approximately)	385g
Backlight	Sidelight (LEDs)

**ABSOLUTE MAXIMUM RATINGS**

Item	Min.	Max.	Unit	
Supply Voltage	(V <sub>DD</sub> ), (V <sub>PWM</sub> )	-0.3	4.0	V
	(V <sub>LED</sub> )	0	20	V
Input Signal Voltage	(V <sub>IN</sub> )	-0.3	V <sub>DD</sub> +0.3	V
Operating Temperature		-20	70	°C
Storage Temperature		-30	80	°C
Storage Humidity (Max. wet bulb temp. = 39°C)		10	90	%(RH)

**ELECTRICAL SPECIFICATION (Ta=25°C) (RECOMMENDED OPERATION CONDITION)**

Item	Min.	Typ.	Max.	Unit	Remarks	
Supply Voltage	(V <sub>DD</sub> )	3.0	3.3	3.6	V	
	(V <sub>LED</sub> )	10.8	12.0	13.2	V	
Differential Input Voltage	(V <sub>ID</sub> )	0.25	---	0.45	V	
Common Mode Input Voltage	(V <sub>CM</sub> )	1.0	1.25	2.0	V	
High Level Input Voltage	(V <sub>IH</sub> )	2.2	---	V <sub>DD</sub>	V	REV
Low Level Input Voltage	(V <sub>IL</sub> )	0	---	0.7	V	REV
Backlight ON/OFF signal	(V <sub>ON/OFF</sub> )	2.0	---	V <sub>DD</sub>	V	ON
		0	---	0.8	V	OFF
Luminance control signal	(V <sub>PWM</sub> )	0	---	3.3	V	
Current Consumption	(I <sub>DD</sub> ) <sup>*1</sup>	---	220	---	mA	
	(I <sub>LED</sub> )	---	350	---	mA	PWM=100%
Power Consumption <sup>*1</sup>		---	5.0	---	W	PWM=100%

\*1 : 8 color bars pattern

**OPTICAL SPECIFICATION (Ta=25°C)**

Item	Min.	Typ.	Max.	Unit	Remarks
Contrast Ratio	(CR)	250	370	---	---
Viewing Angle (CR ≥ 10)	(Upper+Lower)	---	100	---	°
	(Left+Right)	---	120	---	°
Response Time	(t <sub>ON</sub> )	---	8	---	ms
	(t <sub>OFF</sub> )	---	17	---	ms
Luminance	(L)	280	400	---	cd/m <sup>2</sup> PWM=100%
Lamp Life Time (MTBF) <sup>*2 *3</sup>			70,000		h PWM=100%

\*2 : Conditions ; Ta=25°C, continuous lighting

\*3 : Definitions of failure ; 1) Lcd luminance becomes half of the minimum value. 2) LED doesn't light normally.

\*The information contained herein is presented only as a guide for the applications of our products. No responsibility is assumed by Toshiba Mobile Display Co., Ltd or other rights of the third parties which may result from its use. No license is granted by implication or otherwise under any patent or patent rights of Toshiba Mobile Display Co., Ltd or others.

\*The information contained herein may be changed without prior notice. It is therefore advisable to contact Toshiba Mobile Display Co., Ltd before proceeding with the design of equipment incorporating this product.

**DIMENSIONAL OUTLINE**

<Front side>

**TENTATIVE**

Unit : mm

Standard tolerance : +/-0.5

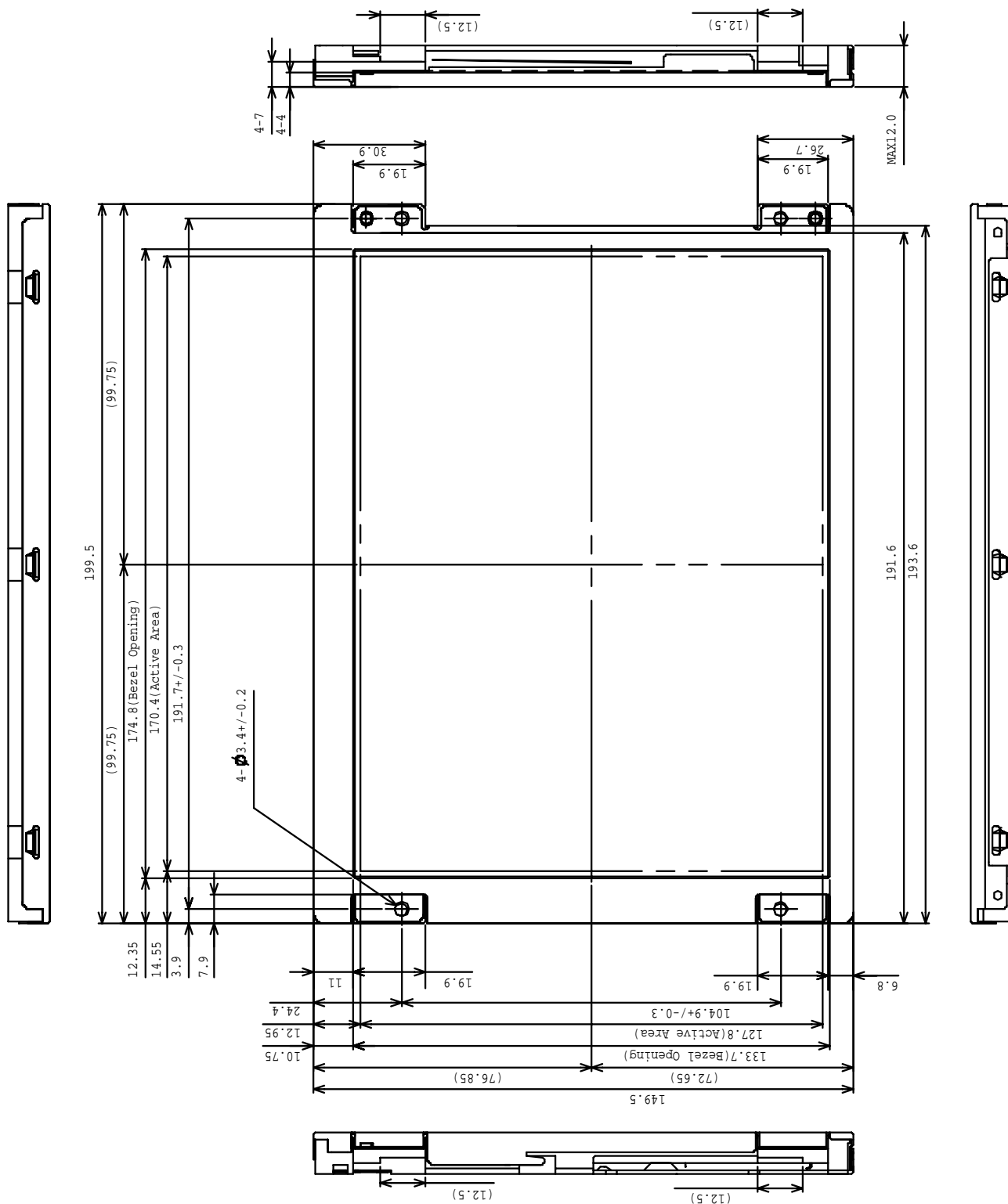

<Rear side>

**TENTATIVE**

Unit : mm

Standard tolerance : +/-0.5

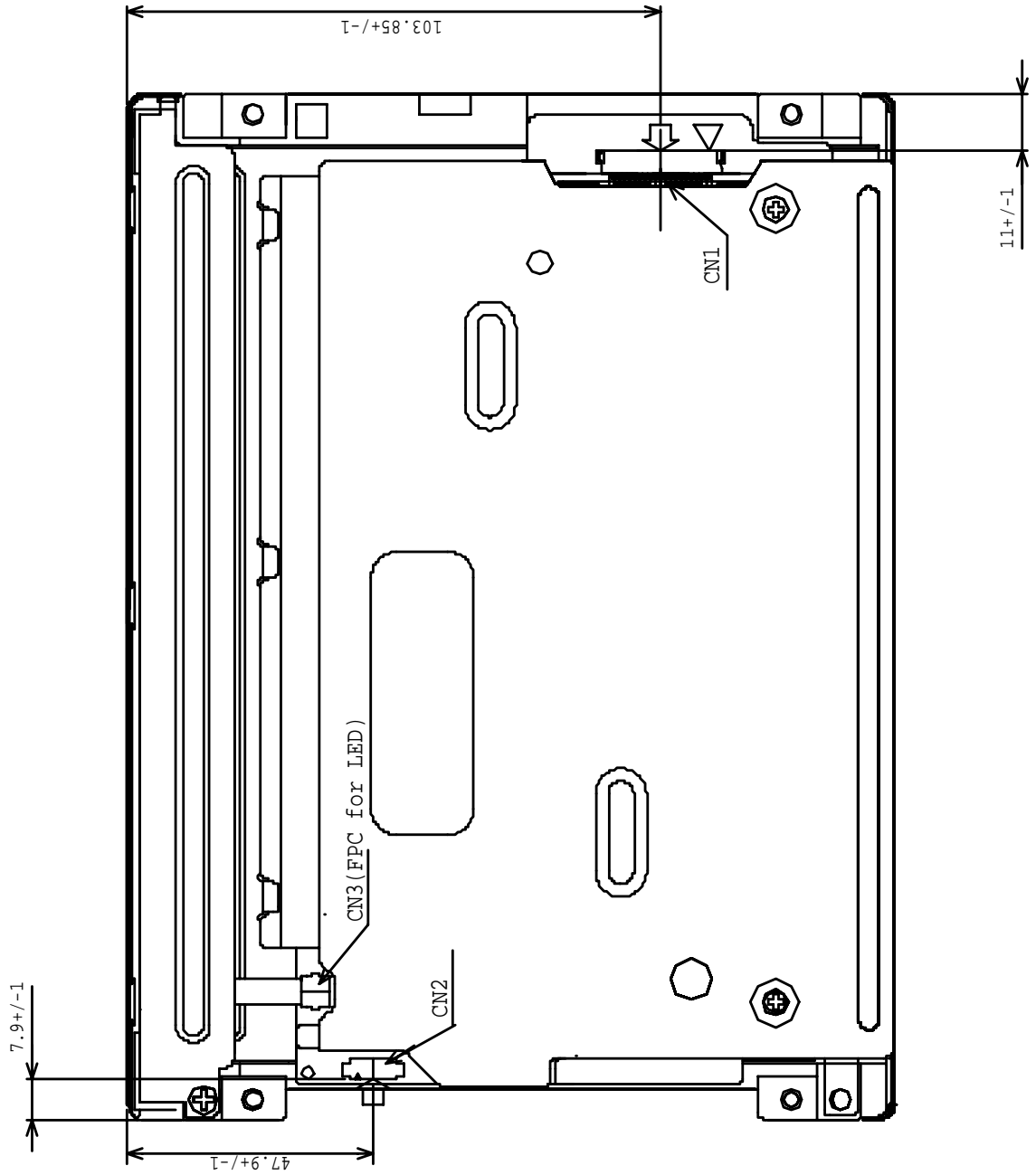

**BLOCK DIAGRAM**

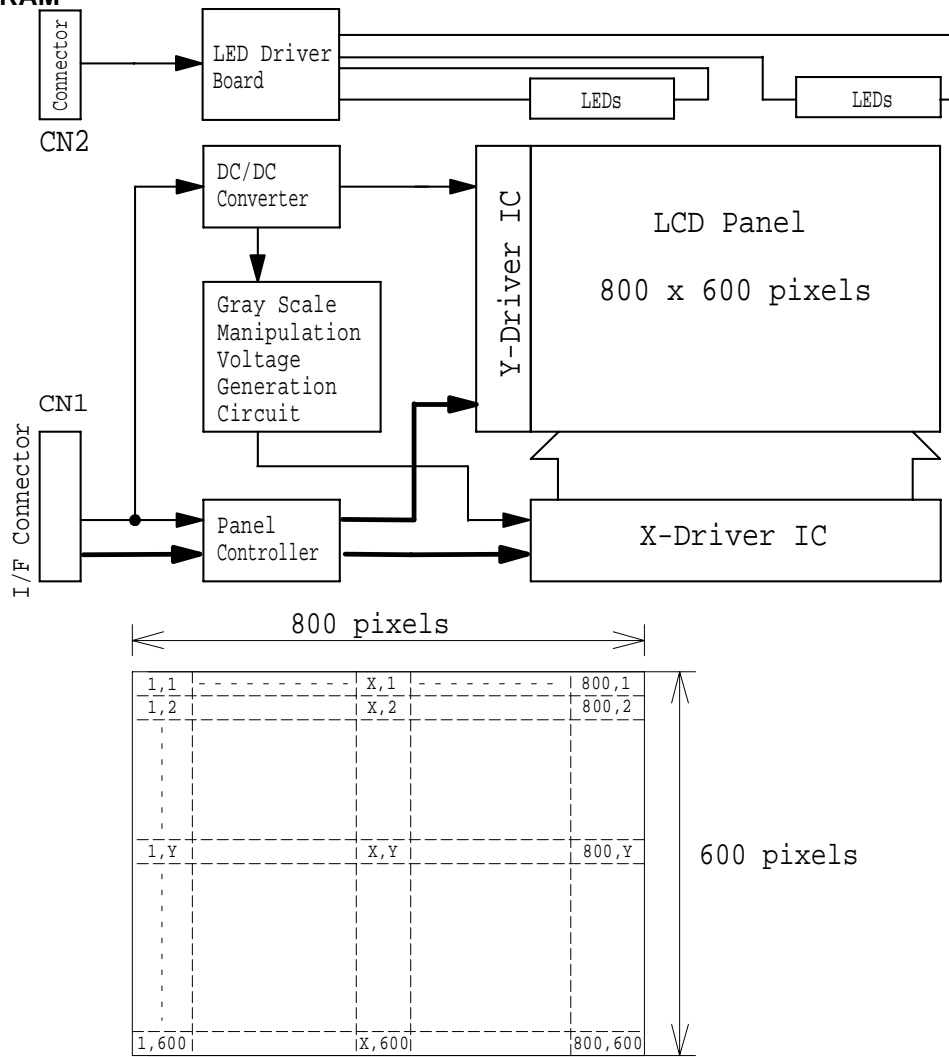

**SEQUENCE OF POWER SUPPLIES AND SIGNALS**

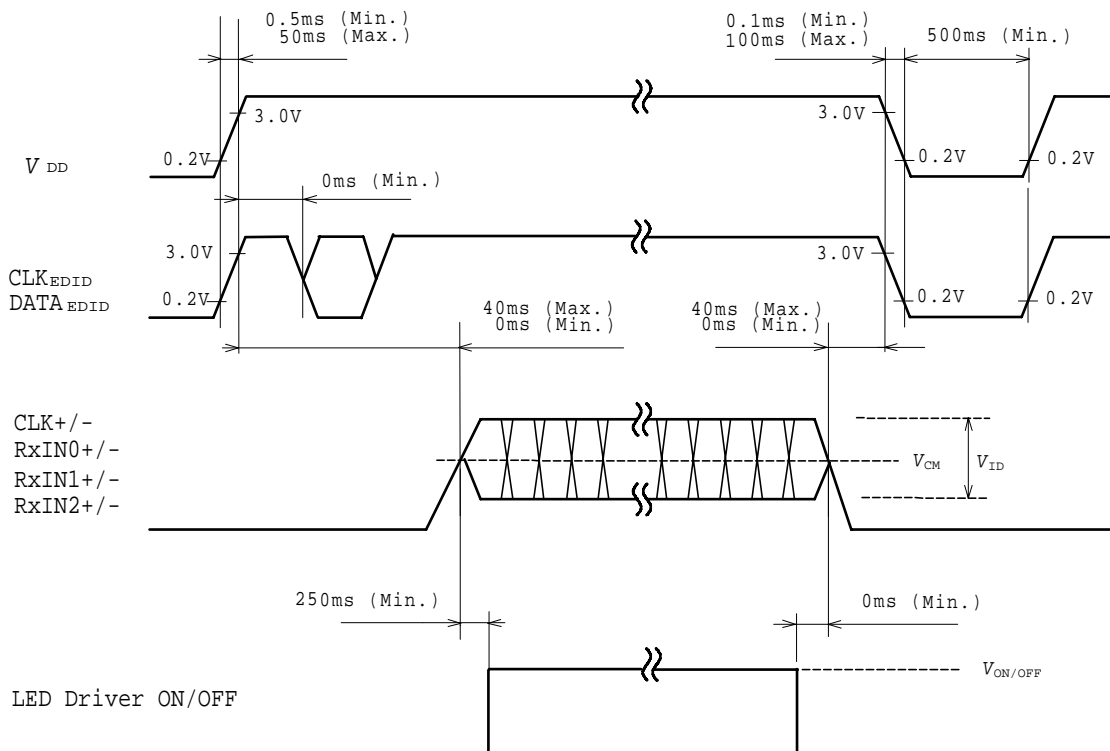

Note 1) When turn  $V_{DD}$  on and turn it off, the form of voltage should be input with no ripple signal.

Note 2) Refer to E<sup>2</sup>PROM(S-24CS01A) specifications by Seiko Instruments Inc. for EDID.

## TIMING CHART

## (1) Vertical Timing

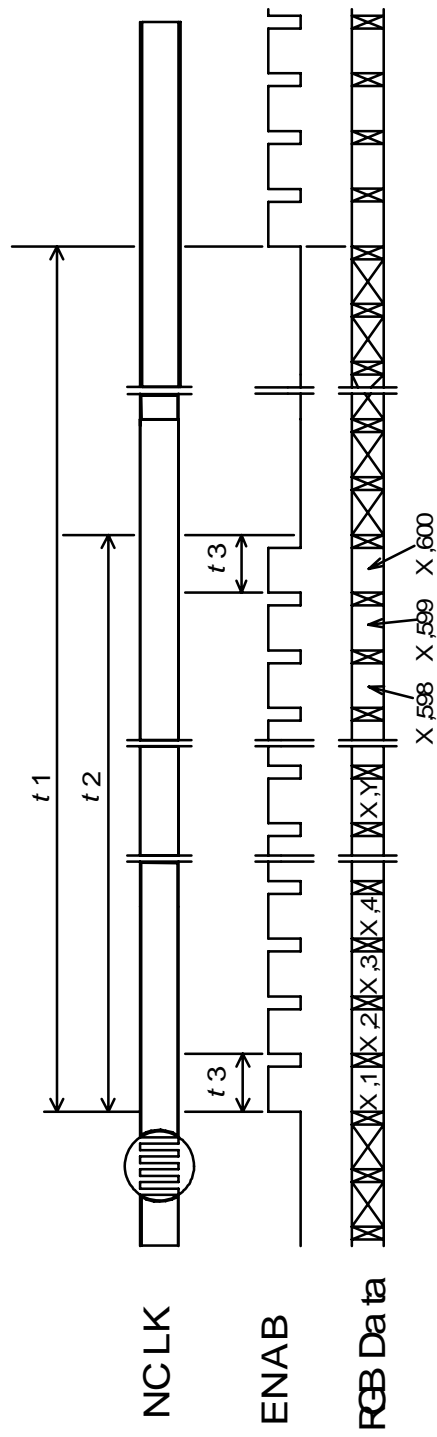

## (2) Horizontal Timing

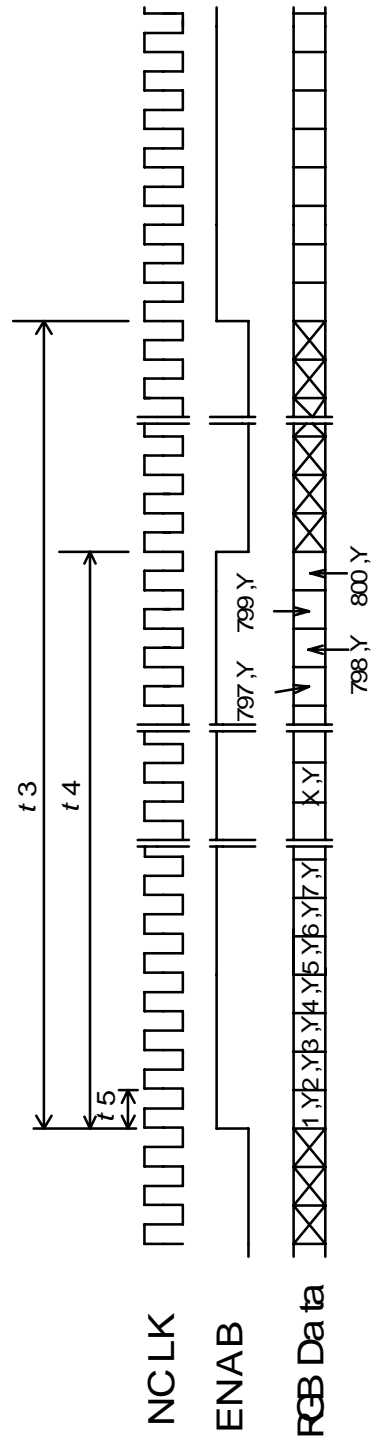

**TIMING SPECIFICATION** \*1 \*2 \*3 \*4 \*5 \*6

Item	Symbol	Min.	Typ.	Max.	Unit	Remarks
Frame Period	$t_1$	604 x $t_3$	628 x $t_3$ 16.58	677 x $t_3$ 17.86	---	
Vertical Display Term	$t_2$	600 x $t_3$	600 x $t_3$	600 x $t_3$	---	
One Line Scanning Time	$t_3$	944 x $t_5$ 26.3	1056 x $t_5$ 26.4	1064 x $t_5$ ---	---	$\mu\text{s}$
Horizontal Display Term	$t_4$	800 x $t_5$	800 x $t_5$	800 x $t_5$	---	
Clock Period	$t_5$	24.7	25.0	27.8	ns	

Note 1) Refer to "TIMING CHART" and LVDS (THC63LVDF84A) specifications by THine Electronics, Inc.

Note 2) If ENAB is fixed to "H" or "L" level for certain period while NCLK is supplied, the panel displays black with some flicker.

Note 3) Don't fix NCLK to "H" or "L" level while the VDD is supplied.

If NCLK is fixed to "H" or "L" level for certain period while ENAB is supplied, the panel may be damaged.

When it holds on, DC voltage supplies to liquid crystal materials and it may cause damage to liquid crystal materials.

Note 4) Please adjust LCD operating signal timing and LED PWM frequency, to optimize the display quality.

There is a possibility that flicker is observed by the interference of LCD operating signal timing and PWM condition (especially driving frequency), even if the condition satisfies above timing specifications and recommended operating conditions shown on page 1.

Note 5) Do not make  $t_1$ ,  $t_2$  and  $t_3$  fluctuate.

If  $t_1$ ,  $t_2$  and  $t_3$  are fluctuate, the panel displays black.

Note 6) Keep constant the number of clock within one line scanning time and the number of scanning line within one frame period.

## CONNECTOR PIN ASSIGNMENT FOR INTERFACE

### CN1 INPUT SIGNAL

Connector : 20268-020E-03F / I-PEX CO., LTD.

Mating Connector : 20230-020B-F or 20230-T20-F or 20230-W20B-F / I-PEX CO.,LTD.

DF19G-20S-1C(Plug), DF19A-2830SCFA(Crimp contact) / HIROSE ELECTRIC CO., LTD.

Terminal No.	Symbol	Function
1	V <sub>DD</sub>	+3.3V POWER SUPPLY
2	V <sub>DD</sub>	+3.3V POWER SUPPLY
3	GND* <sup>1</sup>	
4	GND* <sup>1</sup>	
5	RxIN0-	Negative LVDS differential data input (R0-R5, G0) * <sup>3</sup>
6	RxIN0+	Positive LVDS differential data input (R0-R5, G0) * <sup>3</sup>
7	GND* <sup>1</sup>	
8	RxIN1-	Negative LVDS differential data input (G1-G5, B0-B1) * <sup>3</sup>
9	RxIN1+	Positive LVDS differential data input (G1-G5, B0-B1) * <sup>3</sup>
10	GND* <sup>1</sup>	
11	RxIN2-	Negative LVDS differential data input (B2-B5, NC, NC, DE) * <sup>3</sup>
12	RxIN2+	Positive LVDS differential data input (B2-B5, NC, NC, DE) * <sup>3</sup>
13	GND* <sup>1</sup>	
14	CLK-	Clock Signal (-)
15	CLK+	Clock Signal (+)
16	CLK <sub>EDID</sub>	DDC clock
17	REV	Display Reverse("L" level or Open : Normal, "H" level : Reverse)
18	NC* <sup>2</sup>	Non Connection (open)
19	NC* <sup>2</sup>	Non Connection (open)
20	DATA <sub>EDID</sub>	DDC data

Note 1) Please connect GND pin to ground. Don't use it as no-connect nor connection with high impedance.

Note 2) Please connect NC pin to nothing. Don't connect it to ground nor to other signal input.

Note 3) Refer to next page.

### CN2 LED INPUT SIGNAL

Connector : 53261-0671 / MOLEX Inc.

Mating Connector : 51021-0600 / MOLEX Inc.

Terminal No.	Symbol	Function
1	VLED	Power Supply : +12V
2	VLED	Power Supply : +12V
3	VSS	GND
4	VSS	GND
5	ON/OFF	"H(+3.3V)":ON, "L(GND or Open)":OFF
6	PWM	1-100%(200Hz)

**RECOMMENDED TRANSMITTER (THC63LVDF63A, THC63LVDM63A by Thine Electronics, Inc.)  
TO LTA084C271F INTERFACE ASSIGNMENT**

**Case1: 6bit Transmitter**

THC63LVDF63A, THC63LVDM63A				LTA084C271F Interface (CN1)		
Input Terminal No.		Input Signal (Graphics controller output signal)		Output Signal Symbol	Terminal	Symbol
Symbol	Terminal	Symbol	Function			
TA0	44	R0	Red Pixels Display Data (LSB)	TA- TA+	No.5 No.6	RxIN0- RxIN0+
TA1	45	R1	Red Pixels Display Data			
TA2	47	R2	Red Pixels Display Data			
TA3	48	R3	Red Pixels Display Data			
TA4	1	R4	Red Pixels Display Data			
TA5	3	R5	Red Pixels Display Data (MSB)			
TA6	4	G0	Green Pixels Display Data (LSB)			
TB0	6	G1	Green Pixels Display Data	TB- TB+	No.8 No.9	RxIN1- RxIN1+
TB1	7	G2	Green Pixels Display Data			
TB2	9	G3	Green Pixels Display Data			
TB3	10	G4	Green Pixels Display Data			
TB4	12	G5	Green Pixels Display Data (MSB)			
TB5	13	B0	Blue Pixels Display Data (LSB)			
TB6	15	B1	Blue Pixels Display Data			
TC0	16	B2	Blue Pixels Display Data	TC- TC+	No.11 No.12	RxIN2- RxIN2+
TC1	18	B3	Blue Pixels Display Data			
TC2	19	B4	Blue Pixels Display Data			
TC3	20	B5	Blue Pixels Display Data (MSB)			
TC4	22	HSYNC	H-Sync			
TC5	23	VSYNC	V-Sync			
TC6	25	DE	Compound Synchronization Signal			
CLK IN	26	NCLK	Data Sampling Clock	TCLK- TCLK+	No.14 No.15	CLK- CLK+

Note 1) Please connect NC pin to nothing. Don't connect it to ground nor to other signal input.

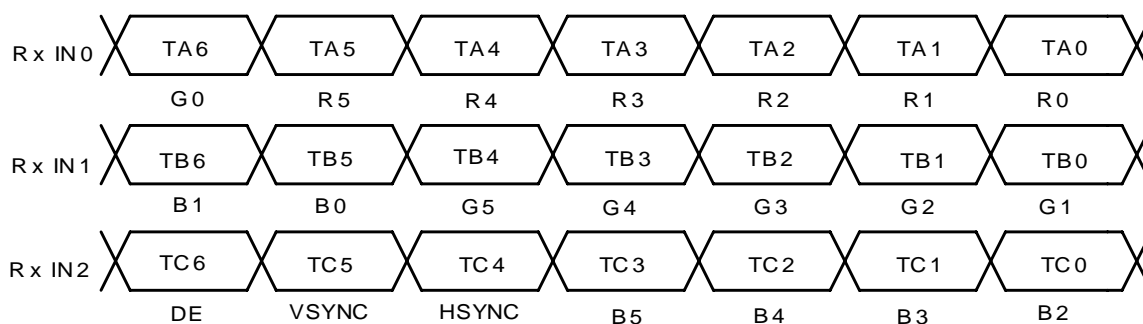



**RECOMMENDED TRANSMITTER (THC63LVDM83D, THC63LVDM83R by THine Electronics, Inc.)  
TO LTA084C271F INTERFACE ASSIGNMENT**

**Case2: 8bit Transmitter**

THC63LVDM83D, THC63LVDM83R				LTA084C271F Interface (CN1)		
Input Terminal No.		Input Signal (Graphics controller output signal)		Output Signal Symbol	Terminal	
Symbol	Terminal	Symbol	Function		Terminal	Symbol
TA0	51	R0	Red Pixels Display Data (LSB)	TA- TA+	No.5 No.6	RxIN0- RxIN0+
TA1	52	R1	Red Pixels Display Data			
TA2	54	R2	Red Pixels Display Data			
TA3	55	R3	Red Pixels Display Data			
TA4	56	R4	Red Pixels Display Data			
TA5	3	R5	Red Pixels Display Data (MSB)			
TA6	4	G0	Green Pixels Display Data (LSB)			
TB0	6	G1	Green Pixels Display Data	TB- TB+	No.8 No.9	RxIN1- RxIN1+
TB1	7	G2	Green Pixels Display Data			
TB2	11	G3	Green Pixels Display Data			
TB3	12	G4	Green Pixels Display Data			
TB4	14	G5	Green Pixels Display Data (MSB)			
TB5	15	B0	Blue Pixels Display Data (LSB)			
TB6	19	B1	Blue Pixels Display Data			
TC0	20	B2	Blue Pixels Display Data	TC- TC+	No.11 No.12	RxIN2- RxIN2+
TC1	22	B3	Blue Pixels Display Data			
TC2	23	B4	Blue Pixels Display Data			
TC3	24	B5	Blue Pixels Display Data (MSB)			
TC4	27	HSYNC	H-Sync			
TC5	28	VSYNC	V-Sync			
TC6	30	DE	Compound Synchronization Signal			
TD0	50	NC <sup>*1</sup>	Non Connection (open)	TD- TD+		
TD1	2	NC <sup>*1</sup>	Non Connection (open)			
TD2	8	NC <sup>*1</sup>	Non Connection (open)			
TD3	10	NC <sup>*1</sup>	Non Connection (open)			
TD4	16	NC <sup>*1</sup>	Non Connection (open)			
TD5	18	NC <sup>*1</sup>	Non Connection (open)			
TD6	25	NC <sup>*1</sup>	Non Connection (open)			
CLK IN	31	NCLK	Data Sampling Clock	TCLK- TCLK+	No.14 No.15	CLK- CLK+

Note 1) Please connect NC pin to nothing. Don't connect it to ground nor to other signal input.

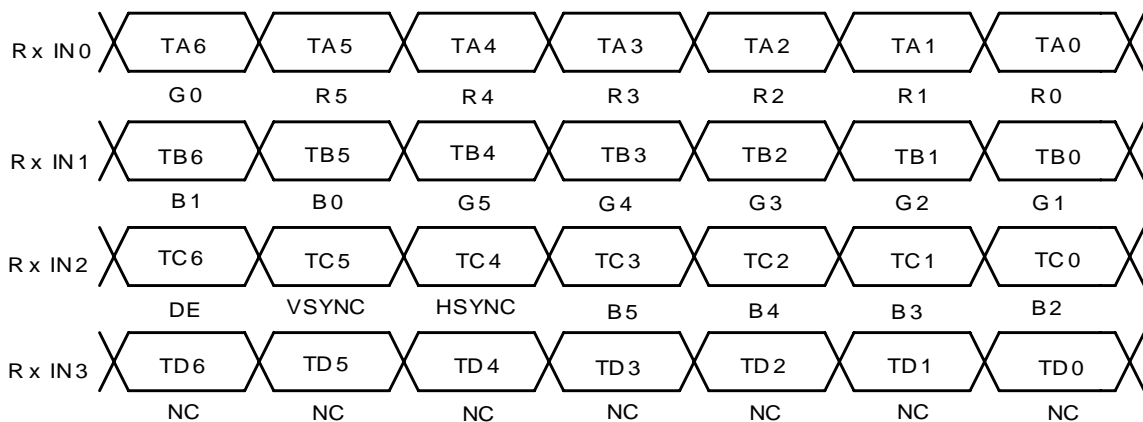

## 256k (k=1024) COLORS COMBINATION TABLE

	Display	R5 R4 R3 R2 R1 R0	G5 G4 G3 G2 G1 G0	B5 B4 B3 B2 B1 B0	Gray Scale Level
Basic Color	Black	L L L L L L L	L L L L L L L	L L L L L L L	---
	Blue	L L L L L L L	L L L L L L L	H H H H H H H	---
	Green	L L L L L L L	H H H H H H H	L L L L L L L	---
	Light Blue	L L L L L L L	H H H H H H H	H H H H H H H	---
	Red	H H H H H H H	L L L L L L L	L L L L L L L	---
	Purple	H H H H H H H	L L L L L L L	H H H H H H H	---
	Yellow	H H H H H H H	H H H H H H H	L L L L L L L	---
	White	H H H H H H H	H H H H H H H	H H H H H H H	---
Gray Scale of Red	Black	L L L L L L L	L L L L L L L	L L L L L L L	L 0
	Dark ↑ ↓ Light	L L L L L H L	L L L L L L L	L L L L L L L	L 1
		L L L L L L L	L L L L L L L	L L L L L L L	L 2
		: : :	: : :	: : :	L3... L60
		H H H H L L H	L L L L L L L	L L L L L L L	L61
	H H H H H L L	L L L L L L L	L L L L L L L	L62	
	Red	H H H H H H H	L L L L L L L	L L L L L L L	Red L63
	Gray Scale of Green	Black	L L L L L L L	L L L L L L L	L L L L L L L
Dark ↑ ↓ Light		L L L L L L L	L L L L L L H	L L L L L L L	L 1
		L L L L L L L	L L L L L H L	L L L L L L L	L 2
		: : :	: : :	: : :	L3... L60
		L L L L L L L	H H H H L L H	L L L L L L L	L61
L L L L L L L		H H H H H L L	L L L L L L L	L62	
Green		L L L L L L L	H H H H H H H	L L L L L L L	Green L63
Gray Scale of Blue		Black	L L L L L L L	L L L L L L L	L L L L L L L
	Dark ↑ ↓ Light	L L L L L L L	L L L L L L L	L L L L L H L	L 1
		L L L L L L L	L L L L L L L	L L L L H L L	L 2
		: : :	: : :	: : :	L3... L60
		L L L L L L L	L L L L L L L	H H H H L L H	L61
	L L L L L L L	L L L L L L L	H H H H H L L	L62	
	Blue	L L L L L L L	L L L L L L L	H H H H H H H	Blue L63
	Gray Scale of White & Black	Black	L L L L L L L	L L L L L L L	L L L L L L L
Dark ↑ ↓ Light		L L L L L L H	L L L L L L H	L L L L L L H	L 1
		L L L L L H L	L L L L L H L	L L L L L H L	L 2
		: : :	: : :	: : :	L3... L60
		H H H H L L H	H H H H L L H	H H H H L L H	L61
H H H H H L L		H H H H H L L	H H H H H L L	L62	
White		H H H H H H H	H H H H H H H	H H H H H H H	White L63

**FOR SAFETY**

LCD module is generally designed with precise parts to achieve light weighted thin mechanical dimensions. In using our Modules, make certain that you fully understand and put into practice the warnings and safety precautions detailed in Engineering Information No.EE-N001,"CAUTIONS AND INSTRUCTIONS FOR TOSHIBA LCD MODULES". Refer to individual specifications and TECHNICAL DATA sheets (hereinafter called "TD") for more detailed technical information.

**1) SPECIAL PURPOSES**

A) Toshiba Mobile Display Co., Ltd 's Standard LCD Modules have not been customized for operation in extreme environments or for use in applications where performance failures could be life-threatening or otherwise catastrophic.

B) Since Toshiba Mobile Display Co., Ltd 's Standard LCD Modules have not been designed for operation in extreme environments, they must never be used in devices that will be exposed to abnormally high levels of vibration or shock which exceed Toshiba Mobile Display Co., Ltd 's published specification limits.

C) In addition, since Toshiba Mobile Display Co., Ltd Standard LCD Modules have not been designed for use in applications where performance failures could be life-threatening or catastrophic, they must never be installed in aircraft navigation control systems (such as, but not limited to Traffic Collision Avoidance System and Air Traffic Indicator), in military defense or weapons systems, in critical industrial process-control systems (e.g., those involved in the production of nuclear energy), or in critical medical device or patient life-support systems.

**2) DISASSEMBLING OR MODIFICATION**

DO NOT DISASSEMBLE OR MODIFY the module. It may damage sensitive parts inside LCD module, and may cause scratches or dust on the display.

Toshiba Mobile Display Co., Ltd does not warrant the module, if customer disassembled or modified it.

**3) BREAKAGE OF LCD PANEL**

DO NOT INGEST liquid crystal material, DO NOT INHALE this material, and DO NOT CONTACT the material with skin, if LCD panel is broken and liquid crystal material spills out.

If liquid crystal material comes into mouth or eyes, rinse mouth or eyes out with water immediately.

If this material contact with skin or cloths, wash it off immediately with alcohol and rinse thoroughly with water.

**4) GLASS OF LCD PANEL**

BE CAREFUL WITH CHIPS OF GLASS that may cause injuring fingers or skin, when the glass is broken.

**5) ELECTRIC SHOCK**

DISCONNECT POWER SUPPLY before handling LCD module.

DO NOT TOUCH the parts inside LCD module and the fluorescent lamp's connector or cables in order to prevent electric shock, because high voltage is supplied to these parts from the inverter unit while power supply is turned on.

**6) ABSOLUTE MAXIMUM RATINGS AND POWER PROTECTION CIRCUIT**

DO NOT EXCEED the absolute maximum rating values under the worst probable conditions caused by the supply voltage variation, input voltage variation, variation in parts' constants, environmental temperature, etc., otherwise LCD module may be damaged.

Employ protection circuit for power supply, whenever the specification or TD specifies it.

Suitable protection circuit should be applied for each system design.

**7) RECOMMENDED OPERATION CONDITIONS**

The performance and quality of the LCD panel are warranted only when the LCD panel is used within "the recommended operation conditions". Toshiba Mobile Display Co., Ltd. never warrants the performance and quality of the LCD panel when you use the LCD panel over "the recommended operation conditions", although within "the absolute maximum rating".

To use the LCD panel over "the recommended operation conditions" may have bad influence on the characteristics and reliability of the LCD panel and may shorten the life of the LCD panel.

Therefore, when designing the whole set, not to be over "the recommended operation conditions", you should fully take care of supply voltage change, characteristic of connection parts, surge of input-and-output line, and surrounding temperature.

**8) DISPOSAL**

When dispose LCD module, obey to the applicable environmental regulations.