

PREPARED BY: _____	DATE _____	<b>SHARP</b>	SPEC No. LCY-02048
APPROVED BY: _____	DATE _____		FILE No. _____
			ISSUE: Apr. 12. 2002
			PAGE : 19pages
		LIQUID CRYSTAL DISPLAY GROUP SHARP CORPORATION SPECIFICATION	APPLICABLE GROUP LIQUID CRYSTAL DISPLAY GROUP

DEVICE SPECIFICATION FOR  
**TFT - LCD module**  
 MODEL No. LQ070T5GG01S

CUSTOMER'S APPROVAL

DATE \_\_\_\_\_

BY \_\_\_\_\_

PRESENTED

BY S. yasuda

S. YASUDA  
 Department General manager  
 Engineering Department 2  
 Mobile LCD Design Center  
 MOBILE LIQUID CRYSTAL DISPLAY GROUP  
 SHARP CORPORATION



## NOTICE

This publication is the proprietary of SHARP and is copyrighted, with all rights reserved. Under the copyright laws, no part of this publication may be reproduced or transmitted in any form or by any means, electronic or mechanical for any purpose, in whole or in part, without the express written permission of SHARP. Express written permission is also required before any use of this publication may be made by a third party.

The application circuit examples in this publication are provided to explain the representative applications of SHARP's devices and are not intended to guarantee any circuit design or permit any industrial property right or other rights to be executed. SHARP takes no responsibility for any problems related to any industrial property right or a third party resulting from the use of SHARP's devices, except for those resulting directly from device manufacturing processes.

In the absence of confirmation by device specification sheets, SHARP takes no responsibility for any defects that occur in equipment using any of SHARP's devices, shown in catalogs, data books, etc. Contact SHARP in order to obtain the latest device specification sheets before using any SHARP's device.

SHARP reserves the right to make changes in the specifications, characteristics, data, materials, structures and other contents described herein at any time without notice in order to improve design or reliability. Contact SHARP in order to obtain the latest specification sheets before using any SHARP's device. Manufacturing locations are also subject to change without notice.

Observe the following points when using any device in this publication. SHARP takes no responsibility for damage caused by improper use of the devices.

The devices in this publication are designed for use in general electronic equipment designs, such as:

- Automotive auxiliary information display
- Automotive audio visual equipment

The appropriate design measures should be taken to ensure reliability and safety when SHARP's devices are used for equipment such as:

- Transportation control and safety equipment (i.e., aircraft, trains, automobiles, etc.)
- Traffic signals                      • Gas leakage sensor breakers
- Alarm equipment                      • Various safety devices etc.

SHARP's devices shall not be used for equipment that requires extremely high level of reliability, such as:

- Military and space applications                      • Nuclear power control equipment
- Medical equipment for life support

Contact a SHARP representative, in advance, when intending to use SHARP's devices for any "specific" applications other than those recommended by SHARP.

Contact and consult with a SHARP representative if there are any questions about the contents of this publication.

## (1) Summary

This module utilizes amorphous silicon thin film transistors and a 16:9 aspect ratio. A 7.0 active matrix liquid crystal display allows full color to be displayed.

An outline of the module is given in Table 1.

## (2) Features

- Utilizes a panel with a 16:9 aspect ratio, which makes the module suitable for use in wide-screen systems.
- The 7.0 screen produces a high resolution image that is composed of 112,320 pixel elements in a stripe arrangement.
- Wide viewing field angle technology is employed. (The most suitable viewing angle is in the 6 o'clock direction.)
- By adopting an active matrix drive, a picture with high contrast is realized.
- Reflection due to external light is minimized through the use of a low reflection, black matrix and an antiglare low reflection (AGLR) plate.
- A thin, light and compact module is accomplished through the use of COG mounting technology.
- By adopting a high aperture panel, high transmittance color filter and high transmission polarizing plates, transmittance ratio is realized.

## (3) Structure and External Shape

External measurements for the module are given in Fig. 1, and the structure of the module is shown in Fig. 2.

The module is composed of the TFT-LCD panel, drivers, frame, backlight, sealed front case, and sealed back case.

## (4) Mechanical specifications

table 1

Parameter	Specifications	Units	Remarks
Display format	336,960	pixels	
	1440(W) × 234(H)	dots	
Active area	154.1 (W) × 87.0 (H)	mm	
Screen size (Diagonal)	17.7 [7.0" ]	cm	
Dot pitch	0.107 (W) × 0.372 (H)	mm	
Pixel configuration	R,G,B Stripe configuration		
Outline dimension	166.0(W) × 102.0(H) × 7.5(D)	mm	【Note1-1】
Mass	205 (max)	g	

【Note1-1】 Typical values are given. For detailed measurements and tolerances, please refer to Fig. 1.

(5)Input / Output terminal 5-1)TFT-LCD panel driving part  
table 2

(H i = VSH, L o = GND)

Pin No.	Symbol	i/o	Description	Remarks
1	VGH	i	Power supply for gate driver(High level).	
2	OPEN	-	Open	
3	OPEN	-	Open	
4	MODE 2	i	Control signal for gate driver.	【Note 2-1】
5	MODE 1	i	Control signal for gate driver.	【Note 2-1】
6	VRV	i	Switching signal of scanning direction for gate driver.	【Note 2-2】
7	SPS	i	Start signal for gate driver.	
8	CLS	i	Clock signal for gate driver.	
9	VCC	i	Power supply for logic circuit in gate driver.(High level)	
10	OPEN	-	Open	
11	OPEN	-	Open	
12	VSS	i	Power supply for logic circuit in gate driver (Low level).	
13	OPEN	-	Open	
14	OPEN	-	Open	
15	VGL	i	Power supply for gate driver (Low level)	
16	COM	i	Common electrode driving signal.	
17	GND	i	Ground	
18	CLD	i	Clock signal for source driver.	
19	SPIO	i/o	Start signal for source driver.	
20	CTR	i	Control signal for source driver.	【Note 2-3】
21	PS	i	Power save signal.	【Note 2-4】
22	HRV	i	Switching signal for source driver.	【Note 2-2】
23	SPOI	o/i	Start signal for source driver.	
24	GND	i	Ground	
25	VB	i	Color video signal (Blue)	
26	VG	i	Color video signal (Green)	
27	VR	i	Color video signal (Red)	
28	GND	i	Ground	
29	VSH	i	Power supply for source driver (High level)	
30	VSH	i	Power supply for source driver (High level)	
31	VSH	i	Power supply for source driver (High level)	
32	VSH	i	Power supply for source driver (High level)	

【Note 2-1】 Refer to 7-7)

【Note 2-2】 Refer to 7-4)

【Note 2-3】 Refer to 7-5)

【Note 2-4】 Please use this terminal in high voltage.

## 5-2) Backlight fluorescent tube driving part

terminal	No.	Symbol	i/o	Function	Remarks
CN 1	1	VL 1	i	Input terminal (high voltage side)	
	2	VL 2	i	Input terminal (high voltage side)	
	3	NC	-	Non connection	
	4	VL 3	i	Input terminal (low voltage side)	【Note3-1】

【Note3-1】 Connect the low voltage side of the DC/AC inverter used to drive the fluorescent tube to GND of the inverter circuit.

(6) Absolute maximum ratings  
table 3

GND = 0 V

Parameter			Symbol	MIN	MAX	Unit	Note
Positive power supply voltage			VSH	-0.3	+6.0	V	T <sub>a</sub> = 25°C
Power supply for gate driver	TFT driving circuit	High level	VGH	-0.3	+33.0	V	"
		Low level	VGL	VGH-33.0	VGH+0.3	V	"
	Logic circuit	High level	VCC	VSS-0.3	VSS+0.7	V	"
		Low level	VSS	VGH-33.0	VGH+0.3	V	"
			VSS-VGL	+0.3	+35	V	"
Analog input signals [terminal 4-1]			VIA	-0.3	VSH+0.3	V	"
Digital input signals [terminal 4-2]			VID	-0.3	VSH+0.3	V	"
Common electrode driving signal			VCDC	-4	+6	V	"
Storage temperature			Tstg.	-30	85	°C	【Note 4-1,2】
Operating temperature (panel surface)			Topr1	-30	85	°C	【Note 4-1,2,3】
Operating temperature ( Ambient temperature )			Topr2	-30	65	°C	【Note 4-4】

[terminal 4-1] VR, VG, VB

[terminal 4-2] CLD, SPIO, SPOI, CTR, HRV, VRV, MODE2, MODE1, SPS, CLS

【Note 4-1】 This rating applies to all parts of the module and should not be exceeded.

【Note 4-2】 Maximum wet-bulb temperature is 58°C. Condensation of dew must be avoided as electrical current leaks will occur, causing a degradation of performance specifications.

【Note 4-3】 The operating temperature only guarantees operation of the circuit. For contrast, speed response, and other factors related to display quality, determine operating temperature using the formula T<sub>a</sub> = +25°C

【Note 4-4】 Ambient temperature when the backlight is lit (reference value).

## (7)Electrical characteristics

## 7-1)Recommended operating conditions

## A)TFT-LCD panel driving section

table 4

GND = 0 V, T<sub>a</sub> = 25 °C

Parameter			Symbol	MIN	TYP	MAX	Unit	Remarks
Power supply for source driver			VSH	+4.8	+5.0	+5.5	V	【Note5-1】
Power supply for gate driver	TFT driving circuit	High level	VGH	+12.5	+13.0	+13.5	V	
		Low level	AC	VGLAC	±0.5	±3.9	±5.0	
	DC		VGLDC	-9.5	-10.0	-10.5	V	
	Logic circuit	High level	VCC	VSS+VSH -0.1	VSS+ VSH	VSS+VSH +0.2	V	
Low level		VSS	-18.0	-17.0	-16.0	V		
Analog input signal [Terminal 2 - 1]	AC component		VIAC	±2.0	-	±2.0	V	【Note5-2】
	DC component		VIDC	VSM-0.1	VSM	VSM+0.1	V	【Note5-3】
Digital input signal [Terminal 2 - 2]	High level		VIDSH	VSH-1.0	-	VSH	V	
	Low level		VIDSL	0	-	1.0	V	
Digital input current [Terminal 2 - 2]	High level		IIDSH	-	-	60.0	μA	VIDSH=VSH
	Low level		IIDSL	-	-	60.0	μA	VIDSL=0V
						2.4	mA	Only HRV
Digital input voltage [Terminal 2 - 3]	High level		VIDGH	VSH-1.0	-	VSH	V	
	Low level		VIDGL	0	-	1.0	V	
Digital input current [Terminal 2 - 2]	High level		IIDGH	-	-	3.0	μA	VIDGH=VSH
	Low level		IIDGL	-	-	3.0	μA	VIDGL=0V
Common electrode driving signal	AC component		VCAC	±0.5	±3.9	±5.0	V <sub>p-p</sub>	【Note 5-1,5-4】
	DC component		VCDC	+0.5	+2.0	+3.5	V	

Cautionary Matter: When applying or disconnecting power, please be sure that such action is simultaneously carried out for all power supplies. In addition, apply input signals only after power has been turned on.

ON ... VSH→VSS→VCC→VGL→VGH      OFF ... VGH→VGL→VCC→VSS→VSH

[terminal 2-1]VR, VG, VB

[terminal 2-2]CLD, SPIO, SPOI, CTR, HRV

[terminal 2-3]MODE 2, MODE 1, VRV, SPS, CLS

【Note5-1】 Any change in voltage after adjusting VCDC should be less than 0.1 V.

【Note5-2】 Positive and negative amplitudes should be equal. When the AC input voltage is -/+ , FRPV and T are in phase. When the AC input voltage is +/ - , FRPV and T are 180° out of phase. The MIN value produces a white display, and the MAX value produces a black display.

【Note5-3】 VSM=VSH/2.

Any change in voltage after adjusting VCDC should be less than 0.1 V.

【Note5-4】 To obtain the maximum value of contrast, each module must be adjusted to an optimum voltage.

## B)Backlight driving section

table 5

Parameter	Symbol	MIN	TYP	MAX	Unit	Remarks
lamp voltage	VL7	380	425	470	V <sub>rms</sub>	I <sub>L</sub> = 5.0mA <sub>rms</sub>
lamp current	IL	3.0	5.0	5.5	mA <sub>rms</sub>	ordinary state
lamp frequency	f <sub>L</sub>	45	-	100	kHz	
kick-off voltage	VS	-	-	1300	V <sub>rms</sub>	T <sub>a</sub> = +25°C
		-	-	1380	V <sub>rms</sub>	T <sub>a</sub> = -30°C

(Inverter : HIU-359A-S2 Harison Electric co. Ltd.)

## 7-2)Electrical characteristics

table 6  $V_{SH}=5.0V, V_{GH}=13.0V, V_{CC}=-10.9V, V_{SS}=-16.0V, V_{GLDC}=-10.0V, V_{GLAC}=\pm 3.9V, GND=0V, T_a=25^{\circ}C$ 

Parameter		Symbol	MIN	TYP	MAX	Unit	Remarks
S O U R C E	Operating Clock frequency	f <sub>CLD</sub>	-	-	5.0	MHz	CLD
	High level clock width	t <sub>WHC</sub>	80.0	-	-	ns	
	Low level clock width	t <sub>WLC</sub>	80.0	-	-	ns	
	Clock rise time	t <sub>RD</sub>	-	-	20.0	ns	
	Clock fall time	t <sub>FD</sub>	-	-	20.0	ns	
	Data set up time	t <sub>SUD</sub>	30.0	-	-	ns	SPIO,SPOI
	Data hold time	t <sub>HD</sub>	30.0	-	-	ns	
	High level pulse width	t <sub>WHD1</sub>	0.4			μs	
	Pulse rise time	t <sub>RP</sub>			20	ns	
	Pulse fall time	t <sub>FP</sub>			20	ns	
G A T E	Operating Clock frequency	f <sub>CLS</sub>	-	-	16.5	kHz	CLS
	Minimum clock pulse with	t <sub>WHS</sub>	0.5	-	-	μs	
	Clock rise time	t <sub>rCL</sub>	-	-	100.0	ns	
	Clock fall time	t <sub>fCL</sub>	-	-	100.0	ns	
	Data set up time	t <sub>SUS</sub>	100.0	-	-	ns	CLS
	Data hold time	t <sub>HS</sub>	300.0	-	-	ns	SPS
	Mode set up time	t <sub>SUM</sub>	300.0	-	-	ns	CLS、MODE2
	Pulse rise time	t <sub>rs</sub>	-	-	100	ns	SPS
Pulse fall time	t <sub>fs</sub>	-	-	100	ns		

7-3)Input signal timing chart  
Refer FIG.47-4)Signal for reverse scanning  
table 7

Mode	HRV	VRV
Normal mode	Hi	Lo
Right/Left reverse mode	Lo	Lo
Up/Down reverse mode	Hi	Hi
Right/Left & Up/Down reverse mode	Lo	Hi

caution) Lo=GND , Hi=VSH

## 7-5)CRT terminal

This is control signal of switching sample holder circuit. Please set the high or low level synchronizing with SPD signal during the period each horizontal line.

※ High level = VSH, Low level = GND

7-6) Current dissipations  
table8T<sub>a</sub> = 25°C

Parameter		Symbol	Conditions	MIN	TYP	MAX	Unit
Current for source driver	Hi	I <sub>SH</sub>	V <sub>SH</sub> =+5.0V	-	45	60	mA
Current for gate driver	Hi	I <sub>GH</sub>	V <sub>GH</sub> =+13.0V	-	0.1	1.0	mA
	Lo	I <sub>GL</sub>	V <sub>GLDC</sub> =-10.0V	-	0.1	1.0	mA
	Logic	I <sub>CC</sub>	V <sub>CC</sub> =-10.9V	-	0.02	1.0	mA
		I <sub>SS</sub>	V <sub>SS</sub> =-16.0V	-	0.2	1.0	mA
Lamp power consumption		WL	Normal driving	-	4.3	-	W



Condition : CLS=15.73kHz, the SPS=60Hz, the SPD=15.73kHz and the CLD=3.99MHz

In case of using exclusive control-IC (LZ9GJ19) and inputting standard NTSC signal.

7-7)Signal for control of gate driver [MODE 1、MODE 2]

table 9

MODE 1	MODE 2	Outputting mode
H i	H i	Normal mode (1 line writing)
L o	H i	2 line same time writing mode
H i	L o	Out of use
L o	L o	No outputting

Coition) Lo=GND , Hi=VSH

(8)Optical characteristics

Table 10

Ta=25°C

Parameter	Symbol	Condition	Min	Typ	Max	Unit	Remarks	
Viewing angle range	$\Delta \theta 11$	CR $\geq$ 5	60	65	-	° (degree)	【Note 6-1,2,3】	
	$\Delta \theta 12$		35	40	-	° (degree)		
	$\Delta \theta 2$		60	65	-	° (degree)		
Contrast ratio	Crmax	Optimal	60	-	-		【Note 6-2,3】	
Response time	Rise	$\theta = 0^\circ$	-	30	60	ms	【Note 6-2,4】	
	Fall		-	50	100	ms		
Luminance	Y	IL=5.0mArms	300	400	-	cd/m <sup>2</sup>	【Note 6-5】	
White chromaticity	x	IL=5.0mArms	0.263	0.313	0.363		【Note 6-5】	
	y	IL=5.0mArms	0.279	0.329	0.379			
lamp life time	+25°C	-	continuation	10,000	-	-	hour	【Note 6-6】
	-30°C	-	intermission	2,000	-	-	time	【Note 6-7】

DC/AC inverter for external connection shown in following.

Harison Co.: HIU-359A-S2 (49kHz)

Please refer to 【Note6-5】 for luminance.

※measuring after 30minutes.

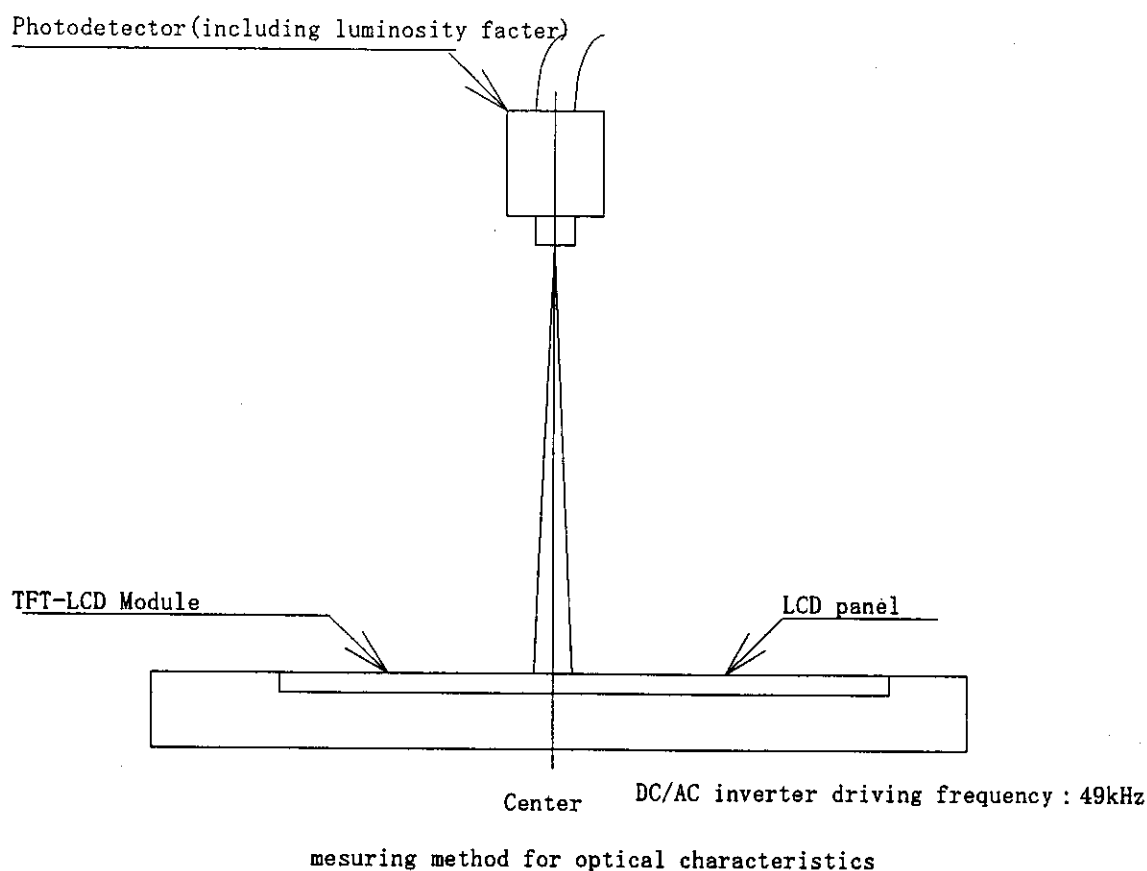

【Note 6-1】 Viewing angle range is defined as follows.

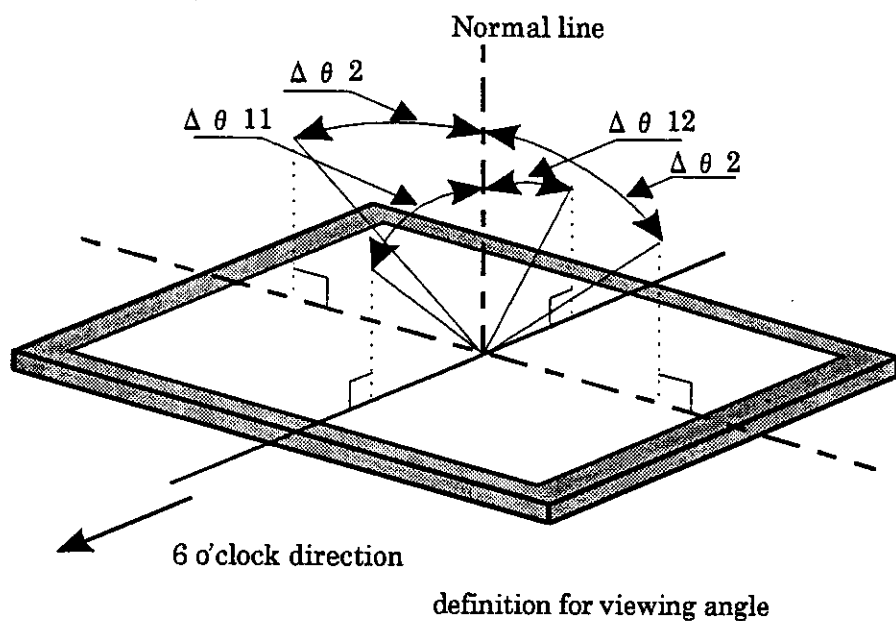

【Note 6-2】 Applied voltage condition:

- (1) VCDC is adjusted so as to attain maximum contrast ratio.
- (2) Input  $\pm 1.90V$  at VIAC.

When VI50= transmission is 50% at Voltage-Transmission curve,  
 Black level : VI50= $\pm 2.5V$ , White level : VI50 =  $\mp 1.5V$

【Note 6-3】 Contrast ratio is defined as follows:

$$\text{Contrast ratio(CR)} = \frac{\text{Photodetector output with LCD being "white"}}{\text{Photodetector output with LCD being "black"}}$$

【Note 6-4】 Response time is obtained by measuring the transition time of photodetector output, when input signals are applied so as to make the area "black" to and from "white".

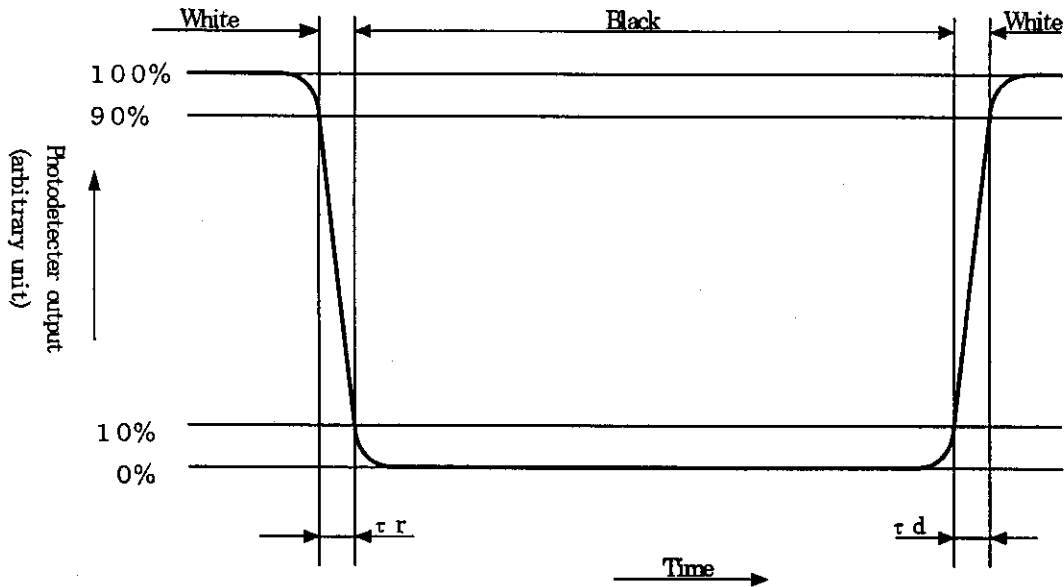

【Note 6-5】 Measured on the center area of the panel at a viewing cone 1° by TOPCON luminance meter BM-7.(After 30 minutes operation)  
DC/AC inverter driving frequency:70kHz  
(Including a rise of 8% in luminance because of rising frequency.)

【Note 6-6】 Lamp life time is defined as the time when either or occurs in the continuous operation under the condition of lamp current  $I_L=3.0\sim 5.5\text{mA}_{rms}$  and PWM dimming 100%~5% ( $T_a=25^\circ\text{C}$ )  
Brightness not to become under 50% of the original value.

【Note 6-7】 The intermittent cycles is defined as a time when brightness not to become under 50% of the original value under the condition of following cycle.  
Ambient temperature:30°C

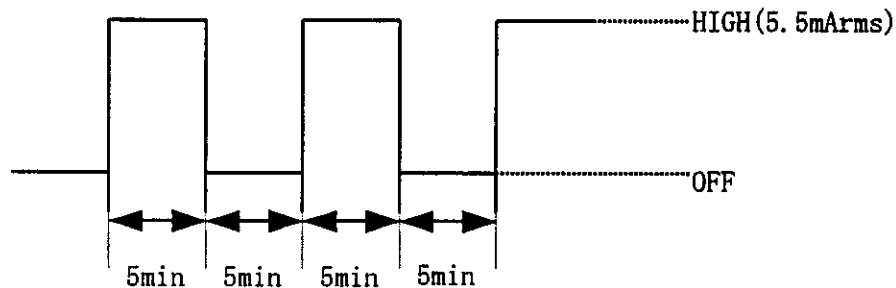

## (9) Mechanical characteristics

## 9-1) External appearance

Do not exist extreme defects. (See Fig. 1)

## 9-2) Panel toughness

The panel shall not be broken, when 19N is pressed on the center of the panel by a smooth sphere having 15 mm diameter.

Caution: In spite of very soft toughness, if, in the long-term, add pressure on the active area, it is possible to occur the functional damage.

## 9-3) I/O connector performance

## A) Input/output connectors for the operation of LCD module

1) Applicable FPC : FCI:SFR32R-1ST

2) FPC flexibility : I. Slit on the film cover lay

If it had been tested bending under radius 0.6 mmR and bending angle 90 degrees condition, the FPC should not be cut at 30 times in or less.

II. Slit on the film cover lay coat part of one side printing

If it had been tested bending under radius nothingness and bending angle 180degrees, the FPC should not be cut.

(It should be bend by hand and only at once).

## B) I/O connector of backlight driving circuit 【JST】

Symbol	Used Connector	Corresponding connector
CN1	BHR-04VS-1	SM04(4.0)B-BHS-1-TB (assembled on PWB)

## (10) Display quality

The display quality of the color TFT-LCD module shall be in compliance with the Incoming Inspection Standard.

## (11) Handling instructions

## 11-1) Mounting of module

The TFT-LCD module is sure to fix the module on the same plane, taking care not to warp or twist the module.

Don't reach the pressure of touch-switches of the set side to a module directly, because images may be disturbed.

Please power off the module when you connect the input/output connector.

Please connect the metallic shielding cases of the module and the ground pattern of the inverter circuit surely. If that connection is not perfect, there may be a possibility that the following problems happen.

- a). The noise from the backlight unit will increase.
- b). The output from inverter circuit will be unstable. Then, there may be a possibility that some problems happen.
- c). In some cases, a part of module will heat.

## 11-2) Precautions in mounting

Polarizer which is made of soft material and susceptible to flaw must be handled carefully. Protective film (Laminator) is applied on the surface to protect it against scratches and dirt. It is recommended to peel off the laminator immediately before the use, taking care of static electricity.

Precautions in peeling off the laminator.

## A) Working environment

When the laminator is peeled off, static electricity may cause dust to stick to the polarizer surface.

To avoid this, the following working environment is desirable.

- a) Floor: Conductive treatment of 1MΩ or more on the tile.  
(conductive mat or conductive paint on the tile)
- b) Clean room free from dust and with an adhesive mat on the doorway
- c) Advisable humidity: 50%~70%      Advisable temperature: 15°C~27°C

- d) Workers shall wear conductive shoes, conductive work clothes, conductive gloves and an earth band.

B) Working procedures

- a) Direct the wind of discharging blower somewhat downward to ensure that module is blown sufficiently. Keep the distance between module and discharging blower within 20 cm.
- b) Attach adhesive tape to the laminator part near discharging blower so as to protect polarizer against flaw.
- c) Peel off laminator, pulling adhesive tape slowly to your side taking 5 or more second.
- d) On peeling off the laminator, pass the module to the next work process to prevent the module to get dust.

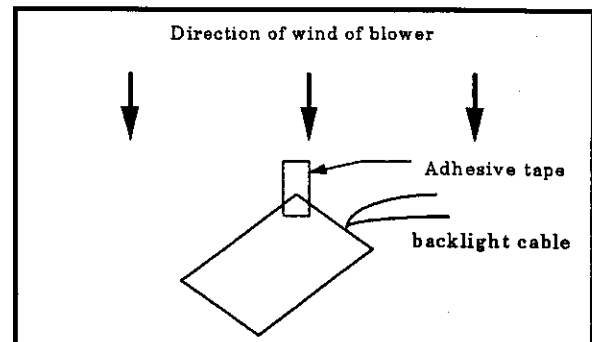
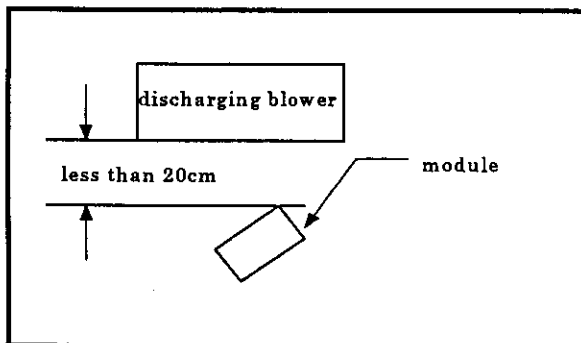

e) Method of removing dust from polarizer

- Blow off dust with N2 blower for which static electricity preventive measure has been taken.  
Ionized air gun (Hugle Electronics Co.) is recommended.
- Since polarizer is vulnerable, wiping should be avoided.  
But when the panel has stain or grease, we recommend to use adhesive tape to softly remove them from the panel.

When metal part of the TFT-LCD module (shielding lid and rear case) is soiled, wipe it with soft dry cloth. For stubborn dirt, breathe on it.

Wipe off water drops or finger grease immediately. Long contact with water may cause discoloration or spots.

TFT-LCD module uses glass which breaks or cracks easily if dropped or bumped on hard surface. Handle with care.

Since CMOS LSI is used in this module, take care of static electricity and earth your body when handling.

11-3) Precautions in adjusting module

Adjusting volumes on the rear face of the module have been set optimally before shipment. Therefore, do not change any adjusted values. If adjusted values are changed, the specifications described here may not be satisfied.

11-4) Caution of product design

The LCD module shall be protected against water salt-water by the waterproof cover. Please take measures to interferential radiation from module, to do not interfere surrounding appliances.

11-5) Others

- ① Do not expose the module to direct sunlight or intensive ultraviolet rays for many hours: liquid crystal is deteriorated by ultraviolet rays.
- ② Store the module at a temperature near the room temperature. At lower than the rated storage temperature, liquid crystal solidifies, causing the panel to be damaged. At higher than the rated storage temperature, liquid crystal turns into isotropic liquid and may not recover.
- ③ The voltage of beginning electric discharge may over the normal voltage because of leakage current from approach conductor by to draw lump read lead line around.

- ④ If LCD panel breaks, there may be a possibility that the liquid crystal escapes from the panel. Since the liquid crystal is injurious, do not put it into the eyes or mouth. When liquid crystal sticks to hands, feet or clothes, wash it out immediately with soap.
- ⑤ Observe all other precautionary requirements in handling general electronic components.
- ⑥ Please adjust the voltage of common electrode as material of attachment by 1 module.

## (12) Shipping form

## 12-1) Packing form (Refer Fig.5)

## 12-2) Carton keeping conditions

①The cartons can be piled up maximum 12 layers.

## ②Environments

Temperature : 0 ~ 40 °C

Humidity : 60 %RH or less (at 40 °C)

No dew condensation at low temperature and high humidity.

Atmosphere : Harmful gas such as acid or alkaline that bites electronic components and/or wires, must not be detected.

Periods : About 3 months

Opening of the package : In order to prevent the LCD module from breakdown by electrostatic charges, please control the humidity over 50%RH and open the package taking sufficient countermeasures against electrostatic charges, such as earth, etc..

## (13) Reliability test

table 13

Remark) Temperature condition is based on operating temperature conditions No. (6) - table5-1.

No.	Test items	Test condition
1	High temperature strong test	Ta = +85°C 240h
2	Low temperature strong test	Ta = -30°C 240h
3	High temperature and high humidity operation test	Ta = +60°C, 90%RH 240h
4	Hi temperature operating test	Tp = +85°C 240h
5	Low temperature operating test	Ta = -30°C 240h
6	Electro static discharge test	±200V · 200pF (0Ω) 1 time for each terminals
7	Shock test	980m/s <sup>2</sup> · 6ms, ± X ; ± Y ; ± Z 3 times for each direction (JIS C0041, A-7 Condition C)
8	Vibration test	Frequency range : 8~33.3Hz Stroke : 1.3mm Sweep : 33.3Hz~400Hz Acceleration : 29.4m/s <sup>2</sup> Cycle : 15 minutes X, Z 2 hours for each directions, 4 hours for Y direction (total 8 hours) [caution] (JIS D1601)
9	Heat shock test	-30°C ~ +85°C / 200 cycles (0.5 h) (0.5 h)

【Note】 Ta = Ambient temperature, Tp = Panel temperature

【Check items】 In the standard condition, there shall be no practical problems that may affect the display function.

【It is the goal specification with a mass production article, and there also is an item which you are not satisfied of this condition in a prototype level.】

【caution】 X, Y, Z direction are shown as follow

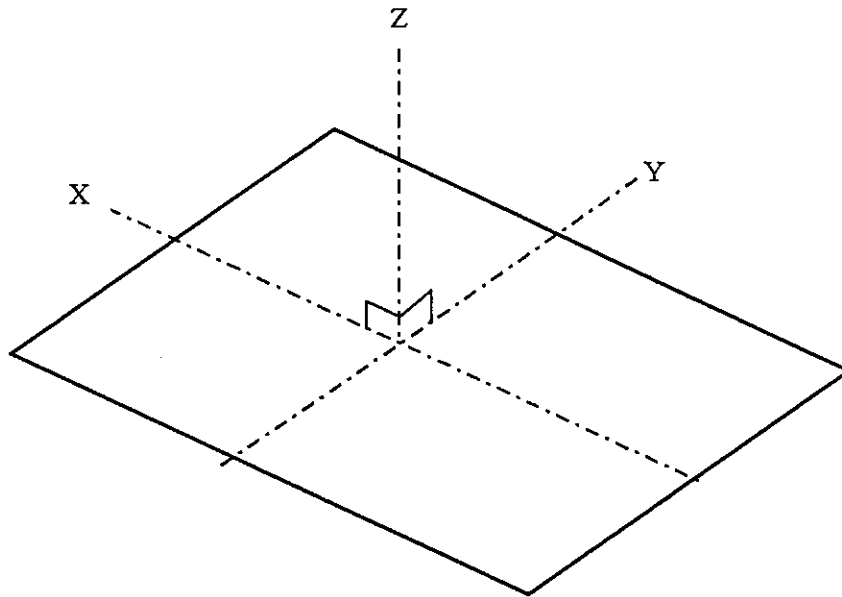

(14) Indication of lot number label

①Attached location of the label : See Fig. 1

②Indicated contents of the label

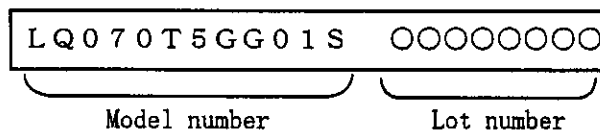

- Contents of lot number
- : 1st .. Production year 2000⇒0
  - : 2nd .. Production month 1, 2, 3, ...9, X, Y, Z
  - : 3rd~7th ..Serial numbers 00001~
  - : 8th .. Revision symbols A, B, C...

SHARP

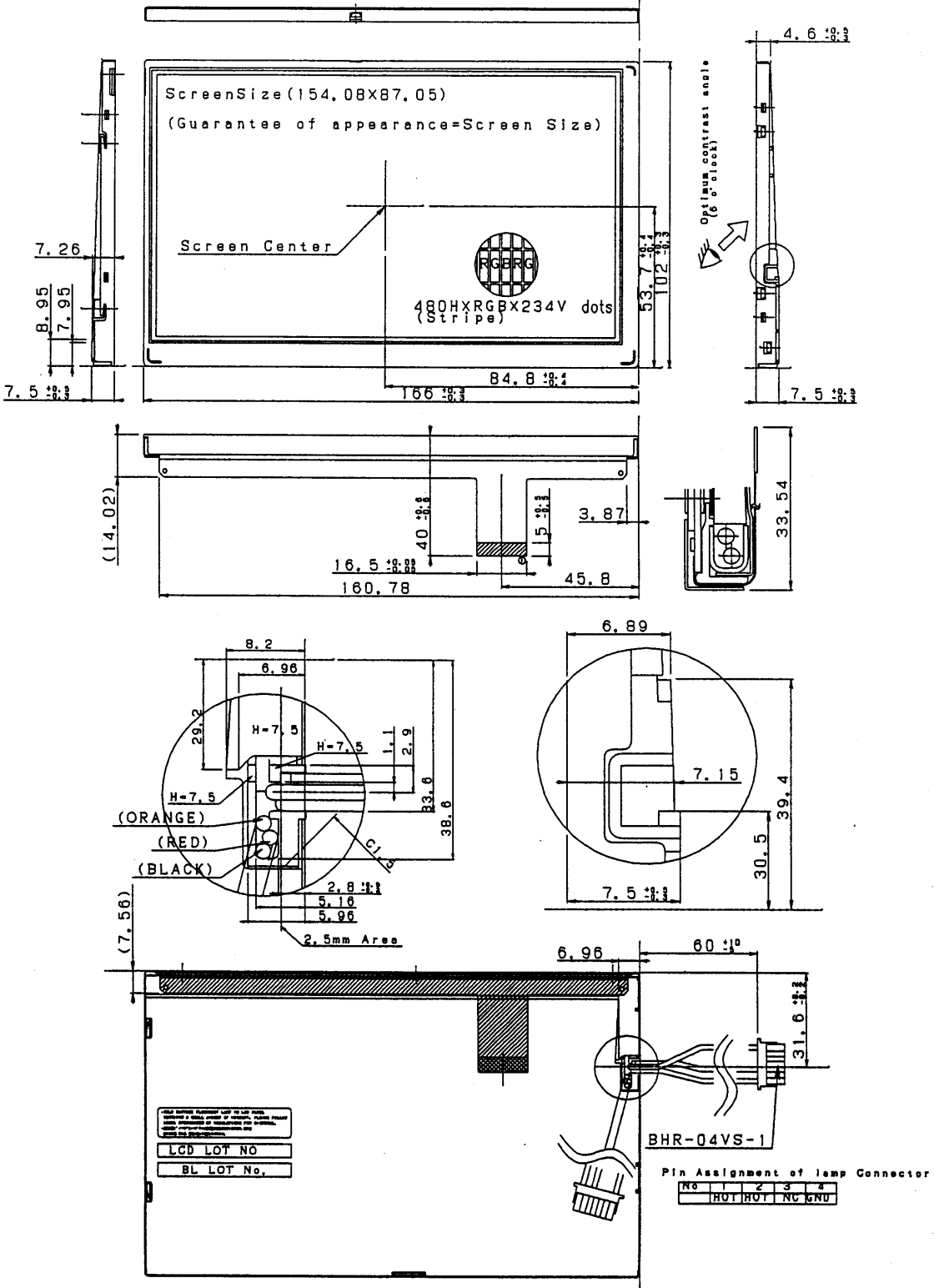

Take care in set design to hide the scratches and bubbles appeared on the polarizer or other frame area which is located outside of active area.

unit:mm		General tolerance is ±0.5		Please do not copy this material and do not disclose this to third party.	
DATE	2002.04.08	SCALE	free		
MODEL	LQ0070T5GG01S				
DRAWING NO	LCM-02041	SIZE	A4	REVISION	
SHARP CO. LTD			ENGINEERING DEPARTMENT 2 MOBILE LCD DESIGN CENTER		

Fig.1 Outline Dimension



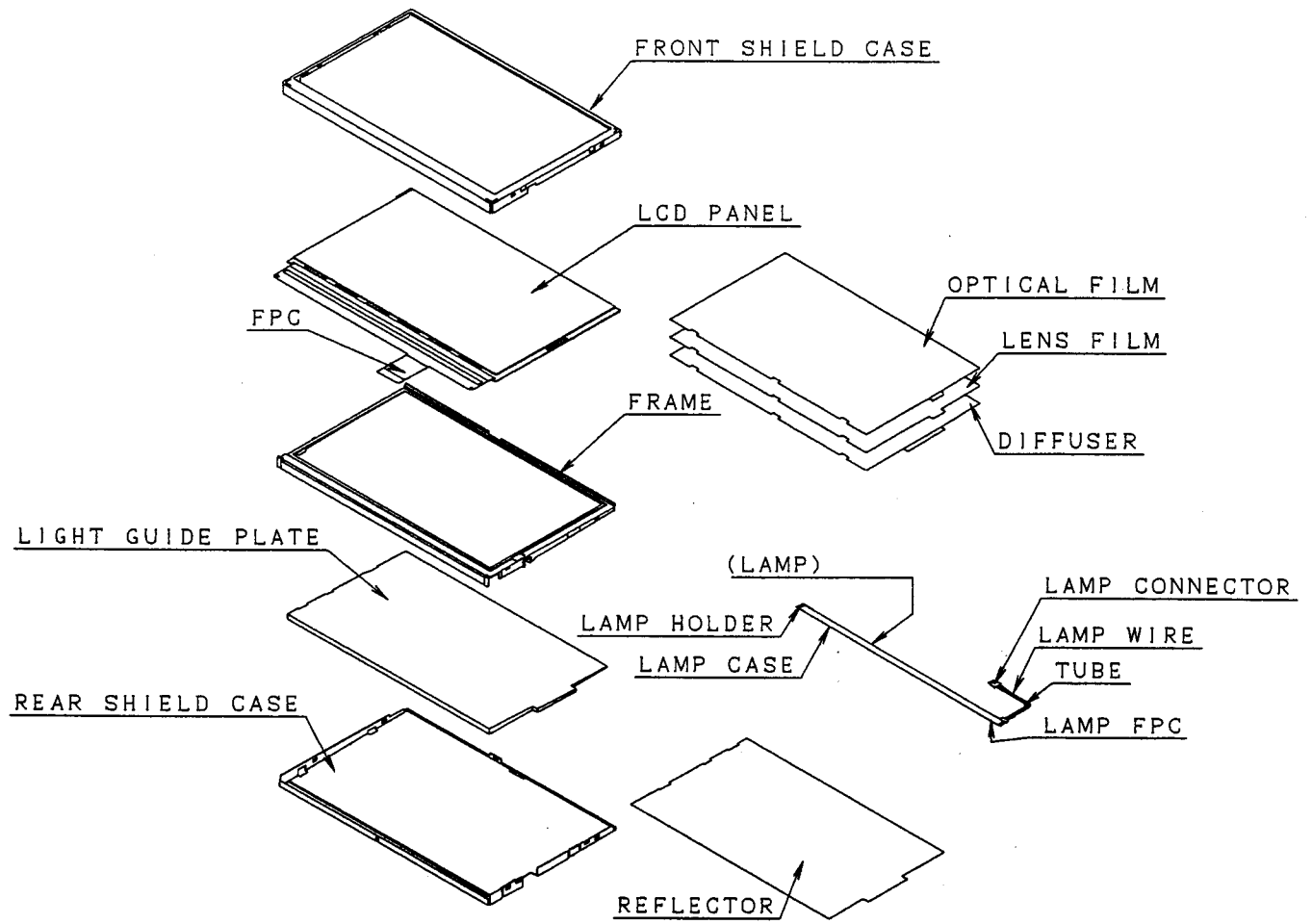

Fig. 2 Structure of the TFT-LCD module

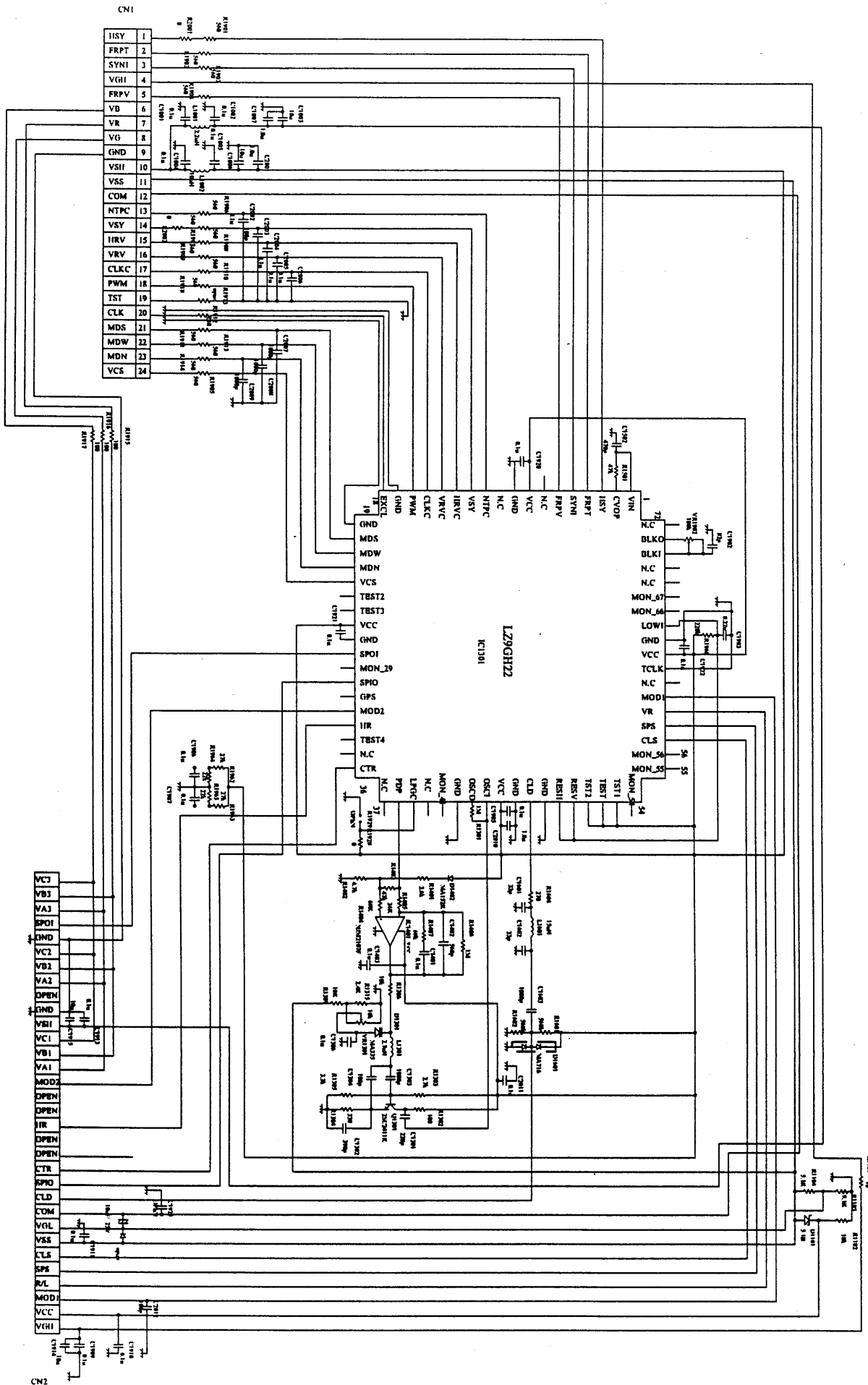

Fig.3 Reference drive circuit

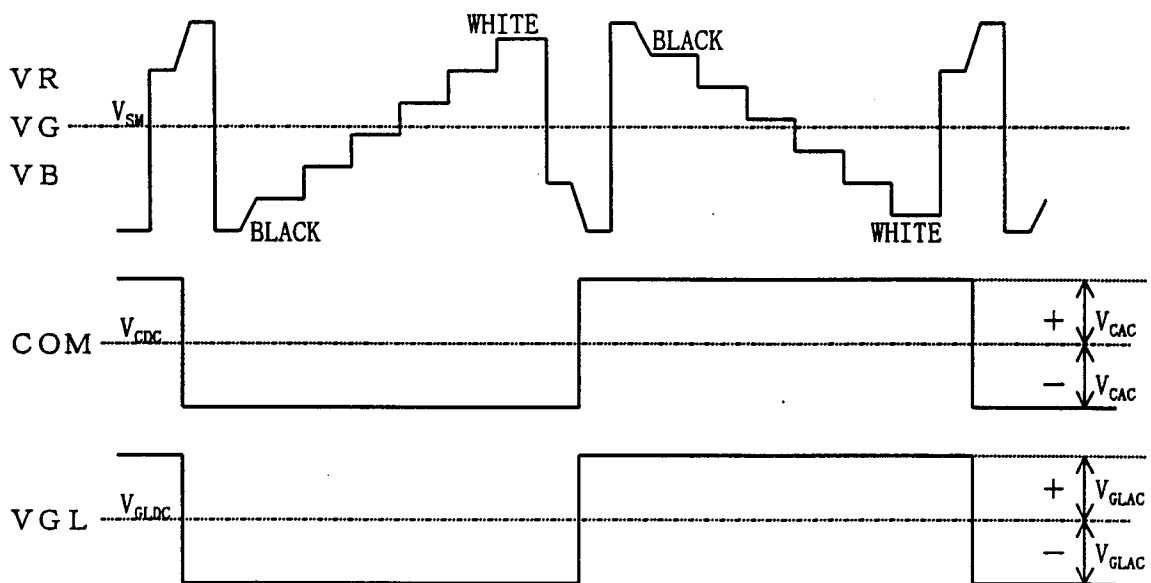
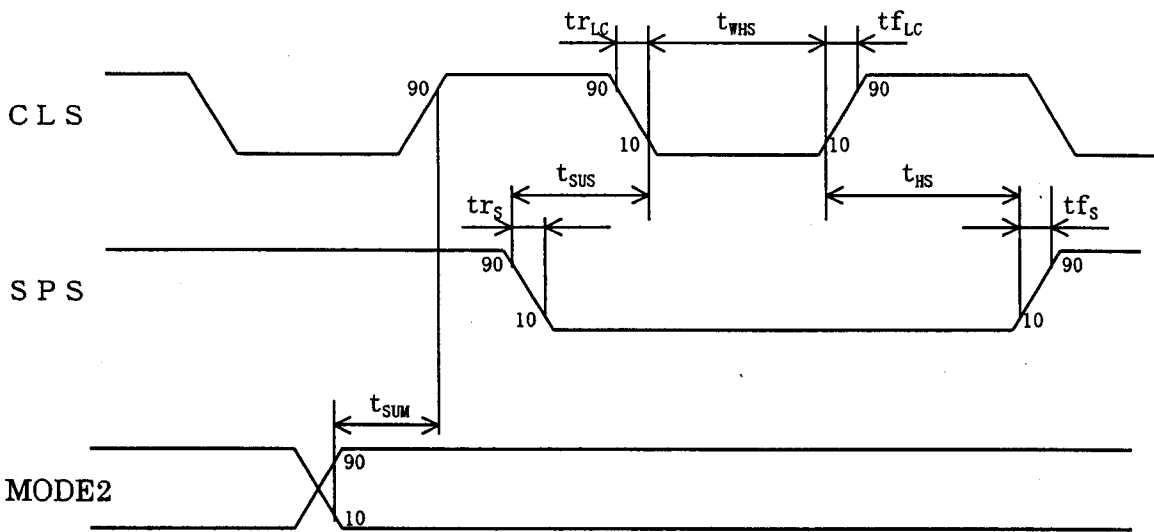
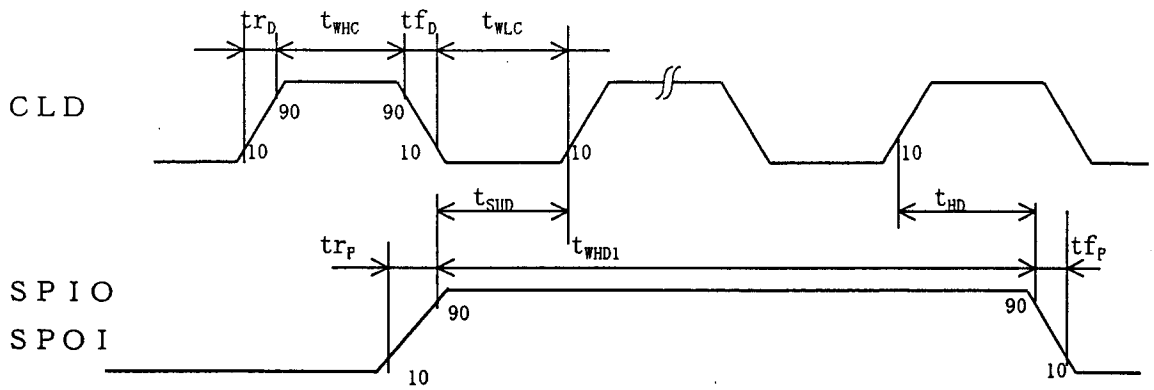

Fig.4 Input signal timing chart

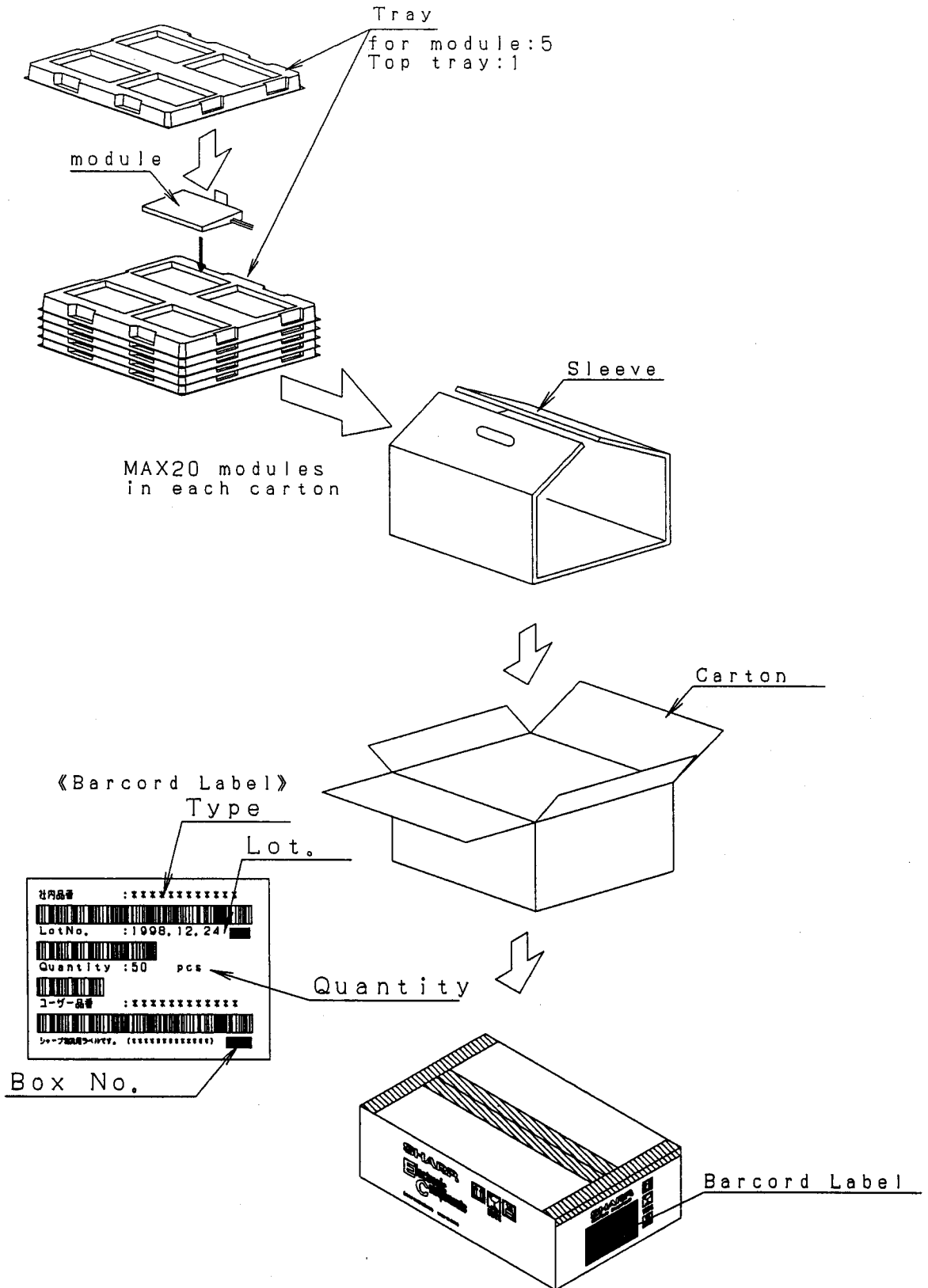

Fig.5-1 Package form

(Appendix)

Adjusting method of optimum common electrode DC bias voltage

To obtain optimum DC bias voltage of common electrode driving signal (VCDC), photoelectric devices are very effective, and the accuracy is with 0.1V. (In visual examination method, the accuracy is about 0.5V because of the difference among individuals.)

To gain optimum common electrode DC bias, there is the method that uses photoelectric devices.

Measurement of flicker

DC bias voltage is adjusted so as to minimize NTSC : 60Hz(30Hz) / PAL : 50Hz(25Hz) flicker.

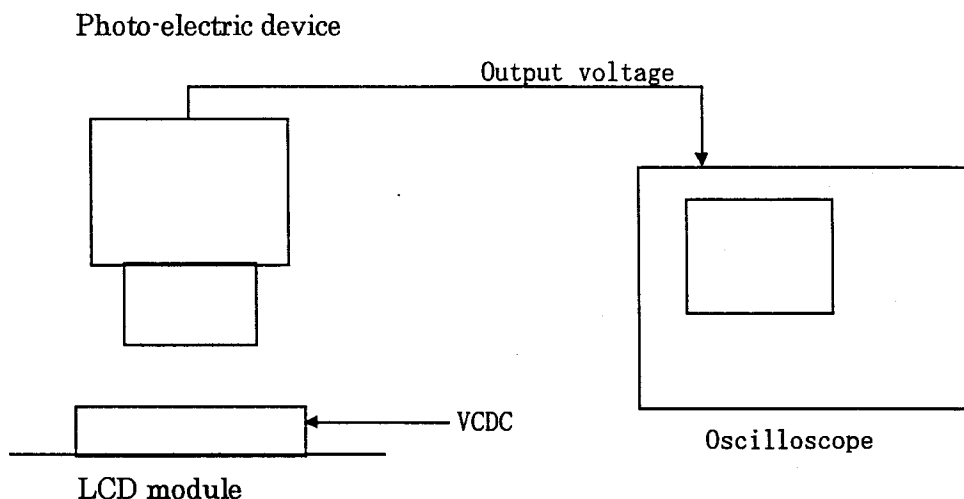

Fig. A Measurement system

《Measurement of flicker》

Photoelectric output voltage is measured by an oscilloscope at a system show in Fig. A.

DC bias voltage must be adjusted so as to minimize the NTSC : 60Hz (30Hz) / PAL : 50Hz (25Hz) flicker with DC bias voltage changing slowly. (Fig.B)

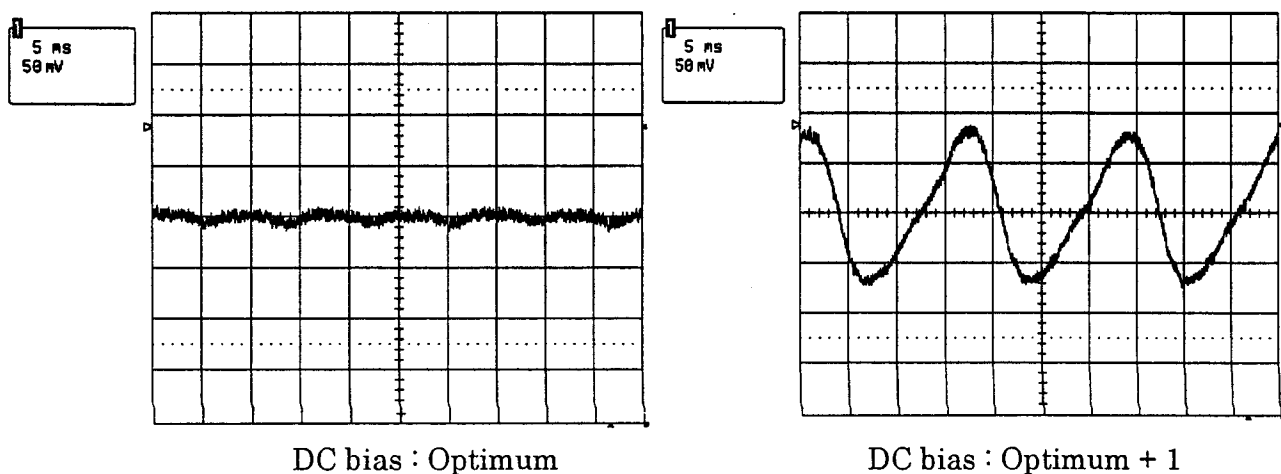

Fig. B Waveforms of flicker