

Product Specification

SPECIFICATION FOR APPROVAL

- (◆) Preliminary Specification
- () Final Specification

Title	13.3" WXGA TFT LCD
-------	--------------------

Customer	General
MODEL	

SUPPLIER	LG.Philips LCD Co., Ltd.
*MODEL	LP133WX2
Suffix	TLC1

*When you obtain standard approval,
please use the above model name without suffix

APPROVED BY	SIGNATURE
/	_____
/	_____
/	_____

Please return 1 copy for your confirmation with your signature and comments.

APPROVED BY	SIGNATURE
K. J. Kwon / S.Manager	_____
REVIEWED BY	
S. W. Paeng / Manager	_____
PREPARED BY	
H. H. Lee / Engineer	_____

**Product Engineering Dept.
LG. Philips LCD Co., Ltd**

Product Specification

Contents

No	ITEM	Page
	COVER	1
	CONTENTS	2
	RECORD OF REVISIONS	3
1	GENERAL DESCRIPTION	4
2	ABSOLUTE MAXIMUM RATINGS	5
3	ELECTRICAL SPECIFICATIONS	
3-1	ELECTRICAL CHARACTREISTICS	6
3-2	INTERFACE CONNECTIONS	7
3-3	LVDS SIGNAL TIMING SPECIFICATIONS	8
3-4	SIGNAL TIMING WAVEFORMS	11
3-5	COLOR INPUT DATA REFERNECE	12
3-6	POWER SEQUENCE	13
4	OPTICAL SFECIFICATIONS	14
5	MECHANICAL CHARACTERISTICS	18
6	RELIABLITY	21
7	INTERNATIONAL STANDARDS	
7-1	SAFETY	22
7-2	EMC	22
8	PACKING	
8-1	DESIGNATION OF LOT MARK	23
8-2	PACKING FORM	23
9	PRECAUTIONS	24
A	APPENDIX. Enhanced Extended Display Identification Data	26

Product Specification

1. General Description

The LP133WX2 is a Color Active Matrix Liquid Crystal Display with an integral LED backlight system. The matrix employs a-Si Thin Film Transistor as the active element. It is a transmissive type display operating in the normally white mode. This TFT-LCD has 13.3 inches diagonally measured active display area with WXGA resolution(1280 horizontal by 800 vertical pixel array). Each pixel is divided into Red, Green and Blue sub-pixels or dots which are arranged in vertical stripes. Gray scale or the brightness of the sub-pixel color is determined with a 6-bit gray scale signal for each dot, thus, presenting a palette of more than 262,144 colors.

The LP133WX2 has been designed to apply the interface method that enables low power, high speed, low EMI.

The LP133WX2 is intended to support applications where thin thickness, low power are critical factors and graphic displays are important. In combination with the vertical arrangement of the sub-pixels, the LP133WX2 characteristics provide an excellent flat display for office automation products such as Notebook PC.

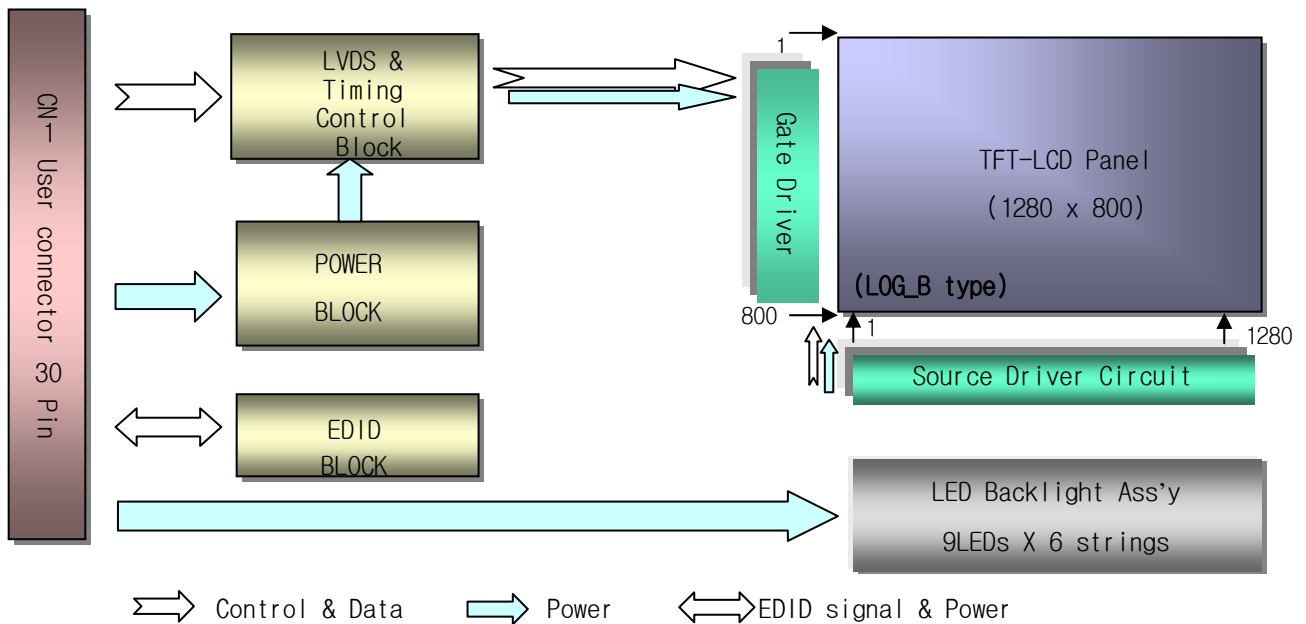

General Features

Active Screen Size	13.3 inches diagonal
Outline Dimension	297.15 (H) × 192.15 (V) × 3.6(D, Max.) mm
Pixel Pitch	0.2235 mm × 0.2235 mm
Pixel Format	1280 horiz. by 800 vert. Pixels RGB strip arrangement
Color Depth	6-bit, 262,144 colors
Luminance, White	275 cd/m ² (Typ., @I _{LED} =19mA)
Power Consumption	Logic : 0.76W(typ. @Mosaic), Back Light : 3.2W(typ. @ I _{LED} = 19mA)
Weight	315(Max.)
Display Operating Mode	Transmissive mode, normally white
Surface Treatment	Hard Coating(Glare), Anti reflection treatment of the front Polarizer (Haze 0%)

Product Specification

2. Absolute Maximum Ratings

The following are maximum values which, if exceeded, may cause faulty operation or damage to the unit.

Table 1. ABSOLUTE MAXIMUM RATINGS

Parameter	Symbol	Values		Units	Notes
		Min	Max		
Power Input Voltage	VCC	-0.3	4.0	Vdc	at 25 ± 5°C
Operating Temperature	TOP	0	50	°C	1
Storage Temperature	HST	-20	60	°C	1
Operating Ambient Humidity	HOP	10	90	%RH	1
Storage Humidity	HST	10	90	%RH	1

Note : 1. Temperature and relative humidity range are shown in the figure below.
Wet bulb temperature should be 39°C Max, and no condensation of water.

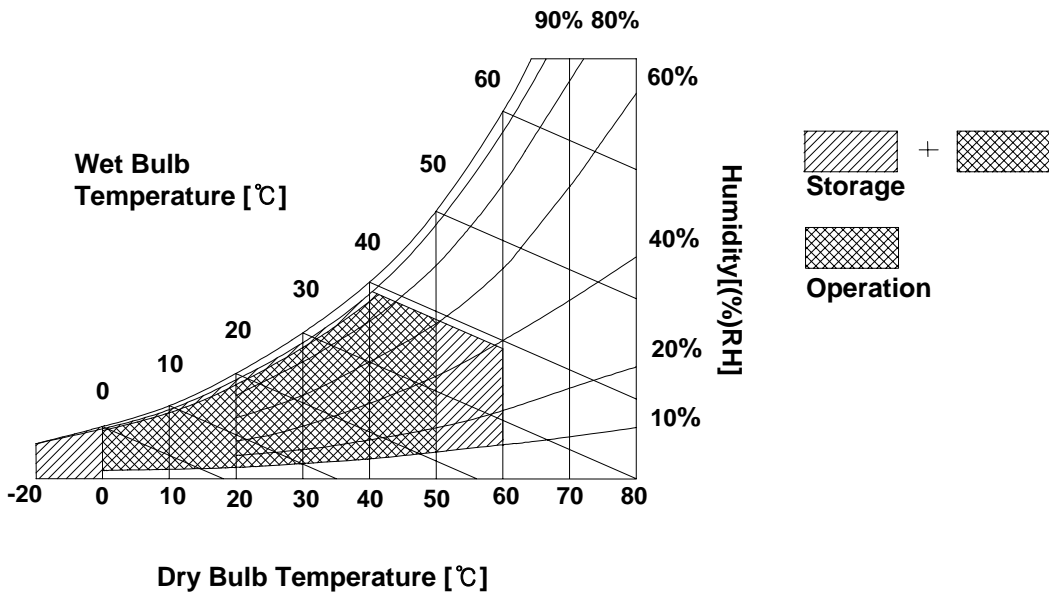

Product Specification

3. Electrical Specifications

3-1. Electrical Characteristics

The LP133WX2 requires two power inputs. One is employed to power the LCD electronics and to drive the TFT array and liquid crystal. The second input which powers the LED BL.

Table 2. ELECTRICAL CHARACTERISTICS

Parameter	Symbol	Values			Unit	Notes
		Min	Typ	Max		
MODULE :						
Power Supply Input Voltage	VCC	3.0	3.3	3.6	V _{DC}	
Power Supply Input Current	I _{CC} Mosaic	-	230	265	mA	1
Power Consumption	P _c	-	0.76	0.875	Watt	1
Differential Impedance	Z _m	90	100	110	Ohm	2
LED Backlight :						
Operating Voltage	V _{LED}	-	27.9	30.6	V	3
Operating Current per string	I _{LED}	5	19	20	mA	4
Power Consumption	P _{BL}	-	3.2	3.5	Watt	5
Life Time		10,000	-	-	Hrs	6

Note)

1. The specified current and power consumption are under the V_{cc} = 3.3V , 25°C , f_v = 1.2Hz condition whereas Mosaic pattern is displayed and f_v is the frame frequency.

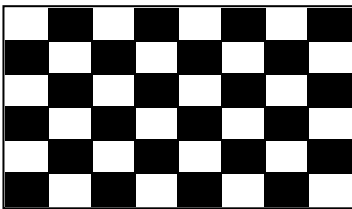

2. This impedance value is needed to proper display and measured form LVDS Tx to the mating connector.
3. The typical operating current is for the typical surface luminance (L_{WH}) in optical characteristics.
4. Define the brightness of the lamp after being lighted for 5 minutes as 100%, T_s is the time required for the brightness of the center of the lamp to be not less than 95%.
5. The life time is determined as the time at which brightness of lamp is 50% compare to that of initial value at the typical lamp current.
6. The life time is determined as the time at which brightness of LED is 50% compare to that of initial value at the typical LED current.

Product Specification

3-2. Interface Connections

This LCD employs two interface connections, a 30 pin connector is used for the module electronics interface and the other connector is used for the integral backlight system.

The electronics interface connector is a model 20347-330E-12 manufactured by I-PEX.

Table 3. MODULE CONNECTOR PIN CONFIGURATION (CN1)

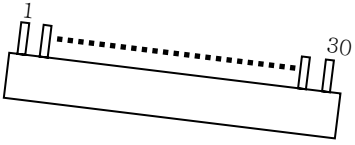
Pin	Symbol	Description	Notes
1	GND	Ground	<p>[LVDS Receiver] SiliconWorks, SW0618V</p> <p>[Connector] I-PEX 20474-030E-12</p> <p>[Mating Connector] I-PEX 20472-030T-10 series or equivalent (micro-coax type)</p> <p>[Connector pin arrangement] LCD front view</p> 
2	VCC	Power Supply, 3.3V Typ.	
3	VCC	Power Supply, 3.3V Typ.	
4	V EEDID	DDC 3.3V power	
5	GSP	GSP	
6	Clk EEDID	DDC Clock	
7	DATA EEDID	DDC Data	
8	R _{IN} 0-	Negative LVDS differential data input	
9	R _{IN} 0+	Positive LVDS differential data input	
10	GND	Ground	
11	R _{IN} 1-	Negative LVDS differential data input	
12	R _{IN} 1+	Positive LVDS differential data input	
13	GND	Ground	
14	R _{IN} 2-	Negative LVDS differential data input	
15	R _{IN} 2+	Positive LVDS differential data input	
16	GND	Ground	
17	CLKIN-	Negative LVDS differential clock input	
18	CLKIN+	Positive LVDS differential clock input	
19	GND	Ground	
20	NC	No Connection	
21	Vdc	LED Anode (Positive)	
22	Vdc	LED Anode (Positive)	
23	NC	No Connection	
24	Vdc1	LED Cathode (Negative)	
25	Vdc2	LED Cathode (Negative)	
26	Vdc3	LED Cathode (Negative)	
27	Vdc4	LED Cathode (Negative)	
28	Vdc5	LED Cathode (Negative)	
29	Vdc6	LED Cathode (Negative)	
30	NC	No Connection	

Product Specification

3-3. LVDS Signal Timing Specifications

3-3-1. DC Specification

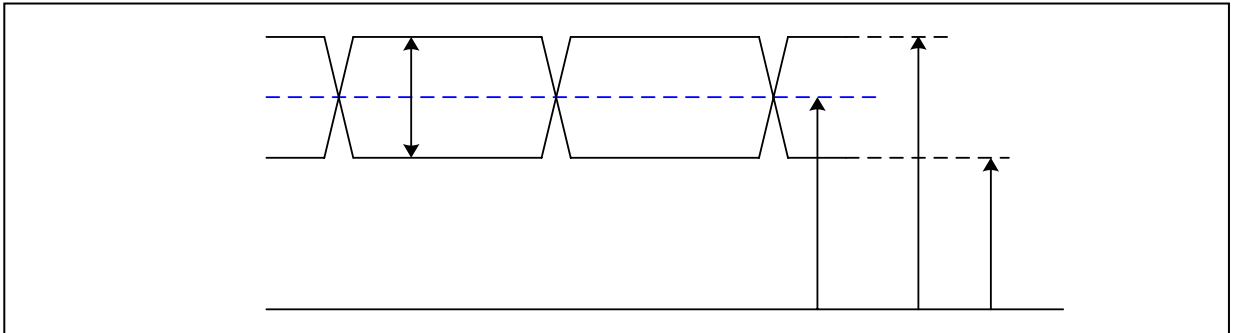

Description	Symbol	Min	Max	Unit	Notes
LVDS Differential Voltage	V _{ID}	100	600	mV	-
LVDS Common mode Voltage	V _{CM}	0.6	1.8	V	-
LVDS Input Voltage Range	V _{IN}	0.3	2.1	V	-

3-3-2. AC Specification

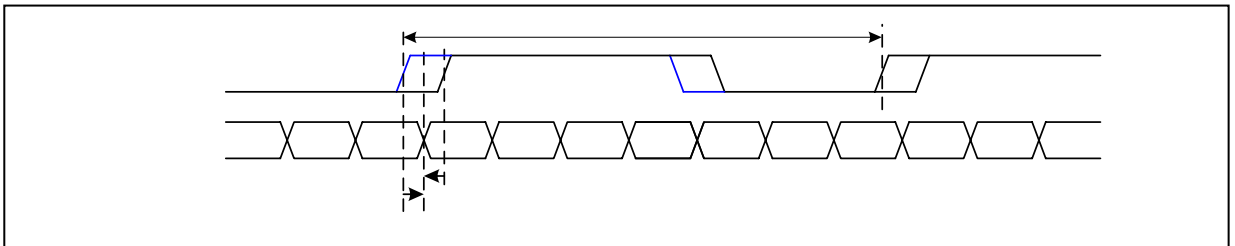

Description	Symbol	Min	Max	Unit	Notes
LVDS Clock to Data Skew Margin	t _{SKEW}	- 400	+ 400	ps	65MHz > F _{clk} ≥ 65MHz
	t _{SKEW}	- 600	+ 600	ps	65MHz > F _{clk} ≥ 25MHz
LVDS Clock to Clock Skew Margin (Even to Odd)	t _{SKEW_EO}	- 1/7	+ 1/7	T _{clk}	-
Maximum deviation of input clock frequency during SSC	F _{DEV}	-	± 3	%	-
Maximum modulation frequency of input clock during SSC	F _{MOD}	-	200	KHz	-

Product Specification

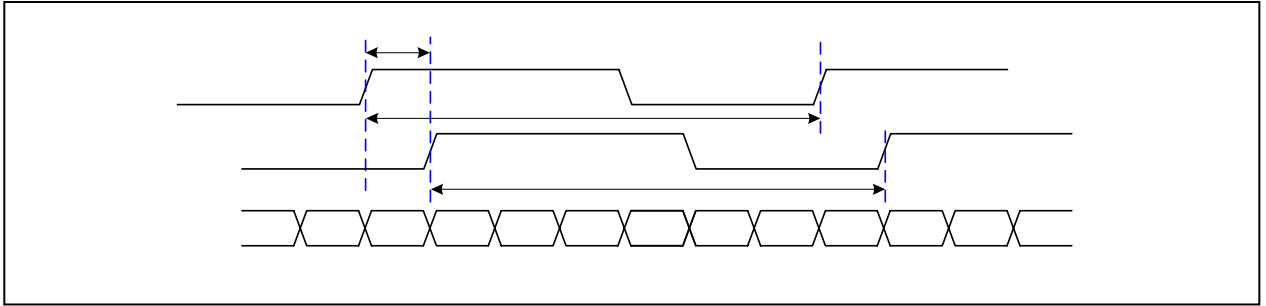

< Clock skew margin between channel >

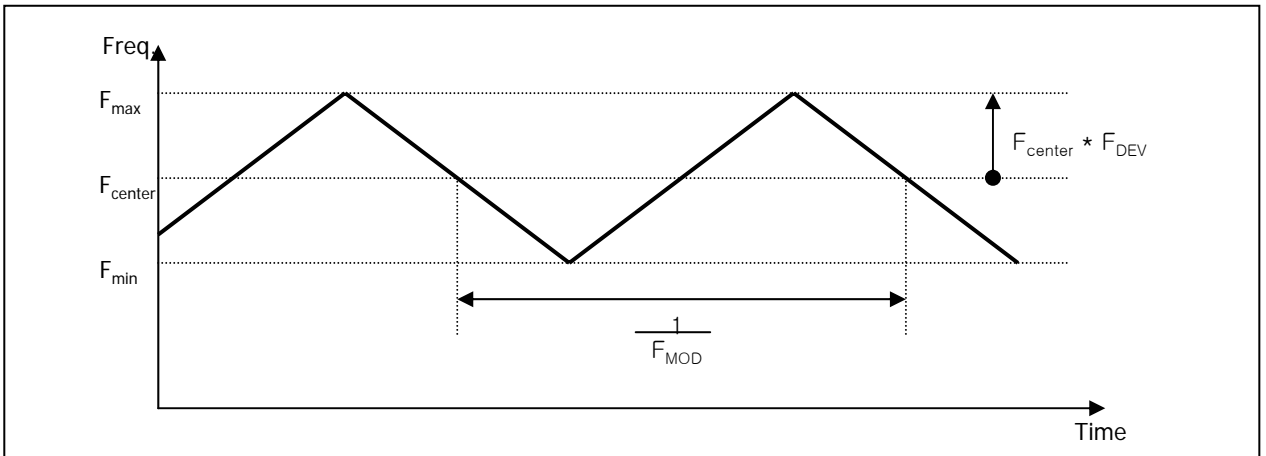

< Spread Spectrum >

3-3-3. Data Format

1) LVDS 2 Port

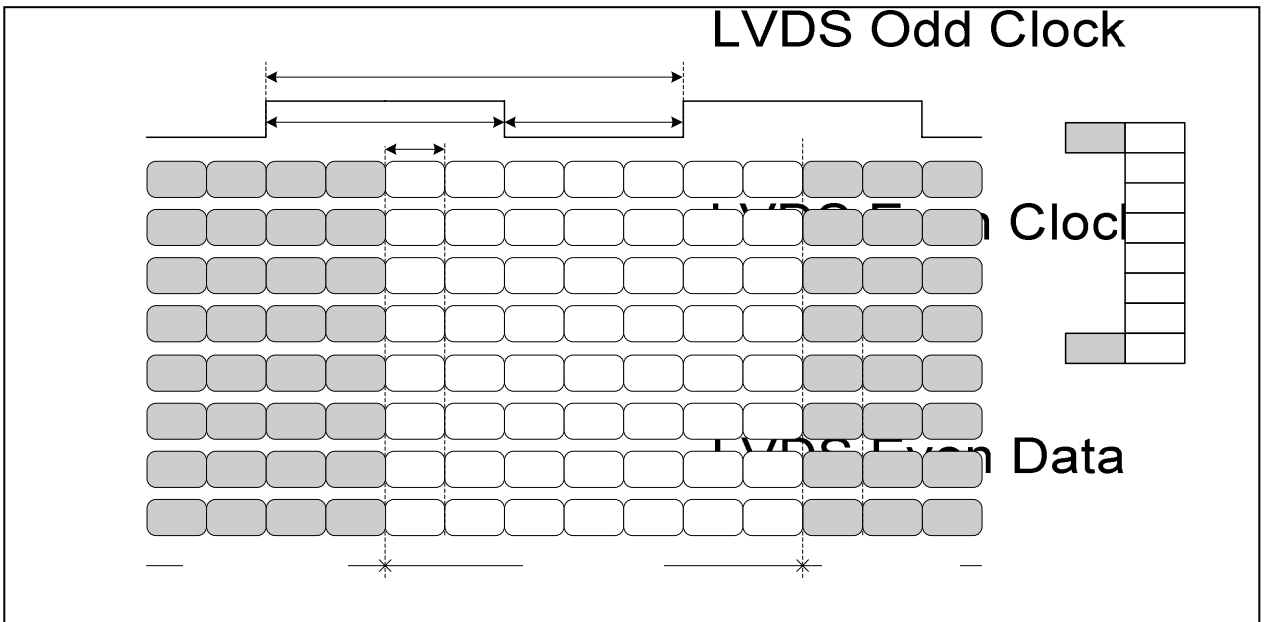

< LVDS Data Format >

Product Specification

2) LVDS 1 Port

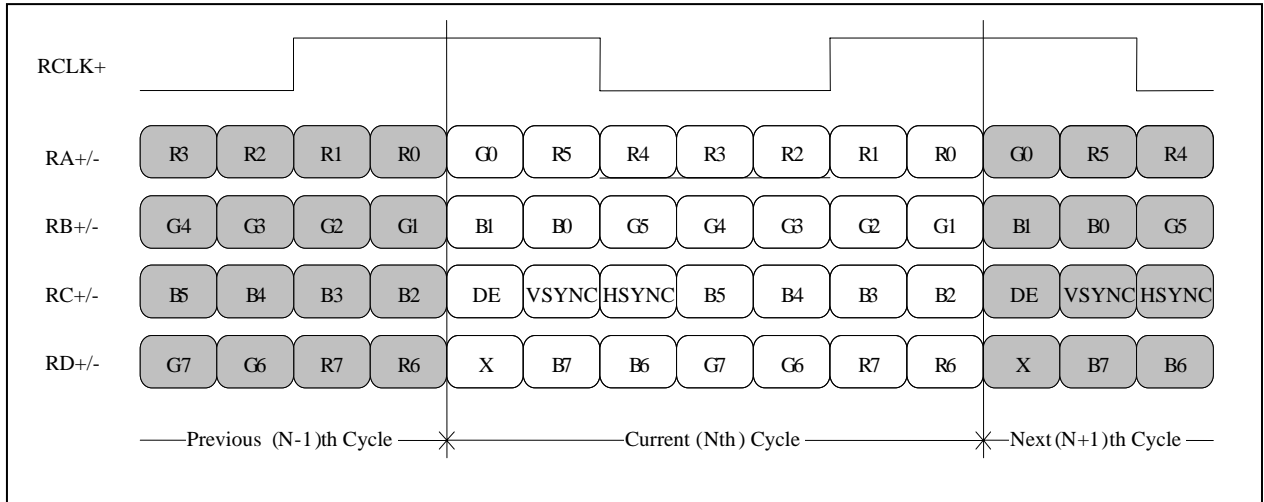

Product Specification

3-4. Signal Timing Specifications

This is the signal timing required at the input of the User connector. All of the interface signal timing should be satisfied with the following specifications and specifications of LVDS Tx/Rx for its proper operation.

Table 6. TIMING TABLE

ITEM	Symbol		Min	Typ	Max	Unit	Note
DCLK	Frequency	f_{CLK}	-	72.5	-	MHz	
Hsync	Period	T_{hp}	1420	1440	1460	Tclk	
	Width	t_{WH}	16	32	48		
	Width-Active	t_{WHA}	1280	1280	1280		
Vsync	Period	t_{VP}	811	823	847	tHP	
	Width	t_{WV}	3	6	9		
	Width-Active	t_{WVA}	800	800	800		
Data Enable	Horizontal back porch	t_{HBP}	54	80	98	tCLK	
	Horizontal front porch	t_{HFP}	16	48	62		
	Vertical back porch	t_{VBP}	5	14	35	tHP	
	Vertical front porch	t_{VFP}	3	3	3		

3-5. Signal Timing Waveforms

Condition : VCC = 3.3V

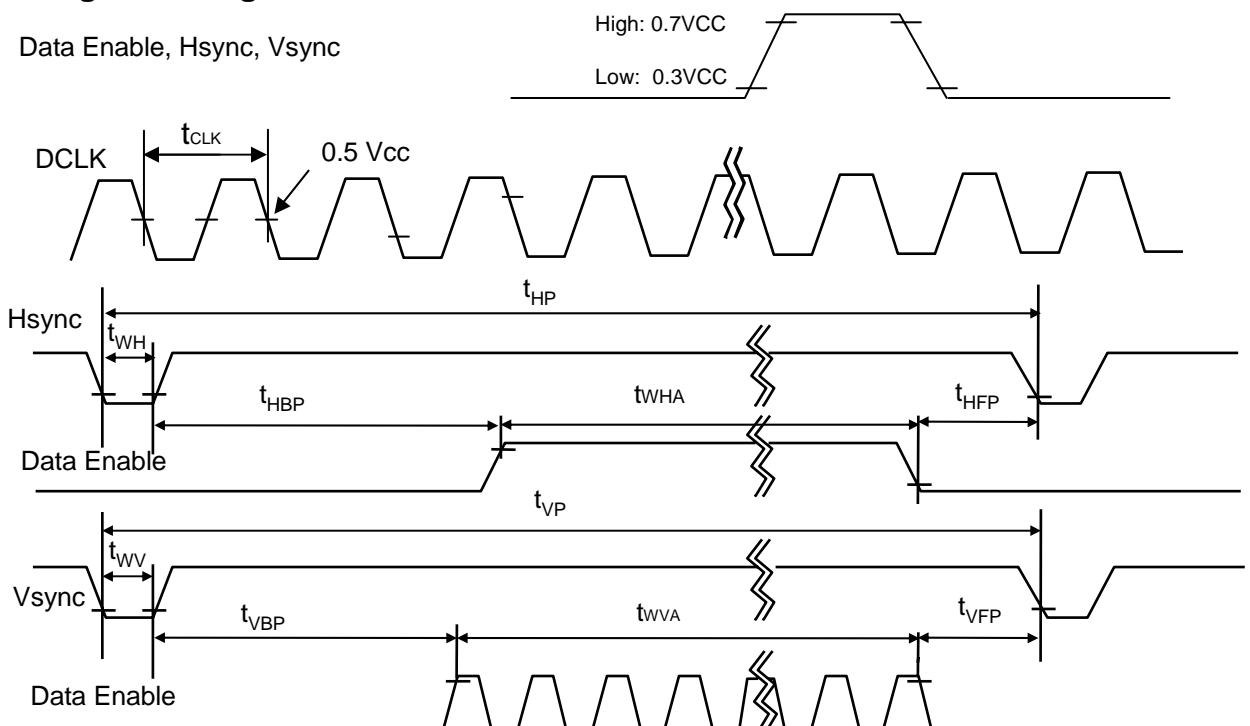

Product Specification

3-6. Color Input Data Reference

The brightness of each primary color (red, green and blue) is based on the 6-bit gray scale data input for the color ; the higher the binary input, the brighter the color. The table below provides a reference for color versus data input.

Table 7. COLOR DATA REFERENCE

Color		Input Color Data																	
		RED						GREEN						BLUE					
		MSB			LSB			MSB			LSB			MSB			LSB		
		R 5	R 4	R 3	R 2	R 1	R 0	G 5	G 4	G 3	G 2	G 1	G 0	B 5	B 4	B 3	B 2	B 1	B 0
Basic Color	Black	0	0	0	0	0	0	0	0	0	0	0	0	0	0	0	0	0	0
	Red	1	1	1	1	1	1	0	0	0	0	0	0	0	0	0	0	0	0
	Green	0	0	0	0	0	0	1	1	1	1	1	1	0	0	0	0	0	0
	Blue	0	0	0	0	0	0	0	0	0	0	0	0	1	1	1	1	1	1
	Cyan	0	0	0	0	0	0	1	1	1	1	1	1	1	1	1	1	1	1
	Magenta	1	1	1	1	1	1	0	0	0	0	0	0	1	1	1	1	1	1
	Yellow	1	1	1	1	1	1	1	1	1	1	1	1	0	0	0	0	0	0
	White	1	1	1	1	1	1	1	1	1	1	1	1	1	1	1	1	1	1
RED	RED (00)	0	0	0	0	0	0	0	0	0	0	0	0	0	0	0	0	0	0
	RED (01)	0	0	0	0	0	1	0	0	0	0	0	0	0	0	0	0	0	0
					
	RED (62)	1	1	1	1	1	0	0	0	0	0	0	0	0	0	0	0	0	0
	RED (63)	1	1	1	1	1	1	0	0	0	0	0	0	0	0	0	0	0	0
GREEN	GREEN (00)	0	0	0	0	0	0	0	0	0	0	0	0	0	0	0	0	0	0
	GREEN (01)	0	0	0	0	0	0	0	0	0	0	0	1	0	0	0	0	0	0
					
	GREEN (62)	0	0	0	0	0	0	1	1	1	1	1	0	0	0	0	0	0	0
	GREEN (63)	0	0	0	0	0	0	1	1	1	1	1	1	0	0	0	0	0	0
BLUE	BLUE (00)	0	0	0	0	0	0	0	0	0	0	0	0	0	0	0	0	0	0
	BLUE (01)	0	0	0	0	0	0	0	0	0	0	0	0	0	0	0	0	0	1
					
	BLUE (62)	0	0	0	0	0	0	0	0	0	0	0	0	1	1	1	1	1	0
	BLUE (63)	0	0	0	0	0	0	0	0	0	0	0	0	1	1	1	1	1	1

3-7. Power Sequence

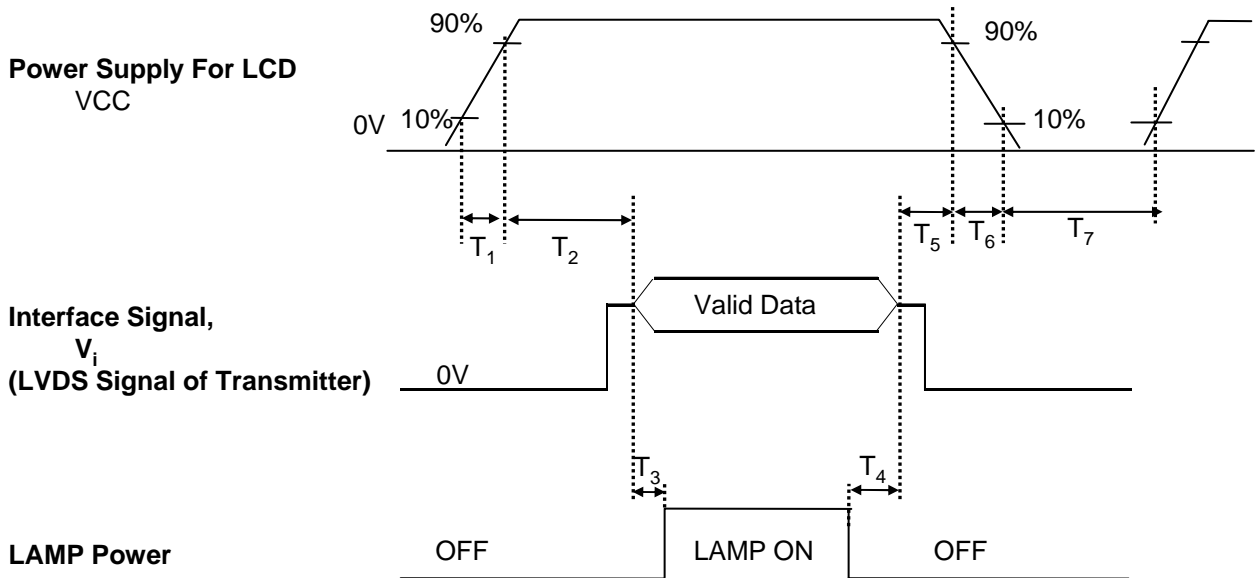

Table 8. POWER SEQUENCE TABLE

Parameter	Value			Units
	Min.	Typ.	Max.	
T ₁	0	-	10	(ms)
T ₂	0	-	50	(ms)
T ₃	200	-	-	(ms)
T ₄	200	-	-	(ms)
T ₅	0	-	50	(ms)
T ₆	0	-	10	(ms)
T ₇	400	-	-	(ms)

Note)

1. Valid Data is Data to meet "3-3. LVDS Signal Timing Specifications"
2. Please avoid floating state of interface signal at invalid period.
3. When the interface signal is invalid, be sure to pull down the power supply for LCD VCC to 0V.
4. Lamp power must be turn on after power supply for LCD and interface signal are valid.

Product Specification

4. Optical Specification

Optical characteristics are determined after the unit has been 'ON' and stable for approximately 20 minutes in a dark environment at 25°C. The values specified are at an approximate distance 50cm from the LCD surface at a viewing angle of Φ and Θ equal to 0°.

FIG. 1 presents additional information concerning the measurement equipment and method.

FIG. 1 Optical Characteristic Measurement Equipment and Method

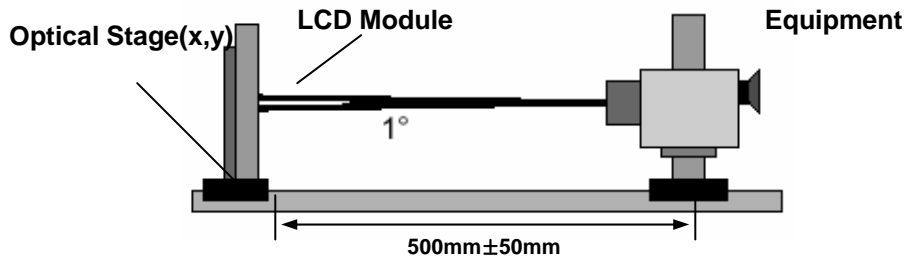

Table 9. OPTICAL CHARACTERISTICS

Ta=25°C, VCC=3.3V, fv=61.2Hz, fCLK= 72.5MHz, ILED = 19mA

Parameter	Symbol	Condition	Min	Typ	Max	Units	Notes
Average Luminance	LAVE	160 Points (ILED= 19mA)	235	275	-	cd/m ²	Fig 2
Luminance variation	%	160 points	60	70	-	-	Fig 2
C/R	-	Center 1 Point	450	600	-	-	
Response time	TrR + TrD	-	-	16	25	ms	Fig 3
Viewing angle	Horizontal	Θ	$\phi x(\text{Left,Right})$	± 45	-	°	Fig 4
	Vertical	Θ	$\phi yu(\text{Up})$	15	-		
		Θ	$\phi yd(\text{Down})$	35	-		
Worst neighbor Brightness uniformity	%		TBD				
White chromaticity deviation (W.R.T center)		d u'v'	-	-	TBD		
White chromaticity deviation (Over panel)		d u'v'	-	-	TBD		
White chromaticity deviation (Worst neighbor)		d u'v'	-	-	TBD		
Cross Talk	DSHA	-	-	-	4.0	%	Fig 5
Gray Scale	-	-	Gamma 2.2				

Product Specification

Table 10. RGB Color Chromaticity

	White		Red		Green		Blue	
	Wx	Wy	Rx	Ry	Gx	Gy	Bx	By
Max.	TBD	TBD	TBD	TBD	TBD	TBD	TBD	TBD
Typ.	0.313	0.329	TBD	TBD	TBD	TBD	TBD	TBD
Min.	TBD	TBD	TBD	TBD	TBD	TBD	TBD	TBD

Notes)

1. Contrast Ratio(CR) is defined mathematically as

$$\text{Contrast Ratio} = \frac{\text{Surface Luminance with all white pixels}}{\text{Surface Luminance with all black pixels}}$$

2. Response time is the time required for the display to transition from white to black (rise time, Tr_R) and from black to white(Decay Time, Tr_D). For additional information see FIG 3.

3. Viewing angle is the angle at which the contrast ratio is greater than 10. The angles are determined for the horizontal or x axis and the vertical or y axis with respect to the z axis which is normal to the LCD surface. For more information see FIG 4.

4. Gray scale specification

* $f_v=61.2\text{Hz}$

Gray Level	Luminance [%] (Typ)
L0	0.16
L7	1.10
L15	4.30
L23	10.4
L31	21.0
L39	35.5
L47	51.5
L55	74.3
L63	100

Product Specification

5. Average Luminance

$$\text{Ave.} = \text{SUM}(L1:L160) / 160$$

where L1 to L160 are the luminance values measured at point #1 to #160.

6. Luminance Uniformity

Luminance Uniformity:

$$U = 100\% - (L_{\text{max}} - L_{\text{min}}) / L_{\text{max}}$$

where, $L_{\text{max}} = \max \{\text{Luminance values at 160 points}\}$,

$L_{\text{min}} = \min \{\text{Luminance values at 160 points}\}$

7. Worst neighbor Luminance Uniformity

Worst Neighbor Luminance Uniformity (The 4 points that are closest to the test point)

$$\text{WNU} = 100\% - \text{Max}(\Delta L1, \Delta L2, \Delta L3, \Delta L4) / L0$$

Global WNU = $\min (\text{WNU}1, \dots, \text{WNU}160)$

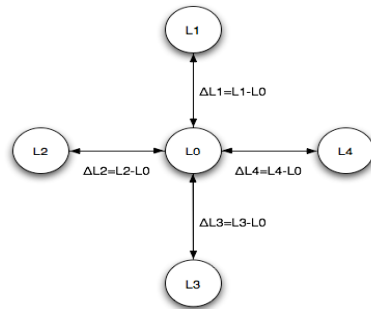

8. White chromaticity deviation – with respect to center

Center color coordinate is defined as the Average of points: 72, 73, 88, 89.

9. White chromaticity deviation – over panel

Maximum delta u'v' between any two measured points over the 160 points

10. White chromaticity deviation – worst neighbor

Maximum delta u'v' between any two neighboring points on the panel

11. White Chromaticity

Average (72, 73, 88, 89 Points)

12. RGB Chromaticity

Center Point

Product Specification

FIG. 2 Luminance

<Measuring point for Average Luminance & measuring point for Luminance variation>

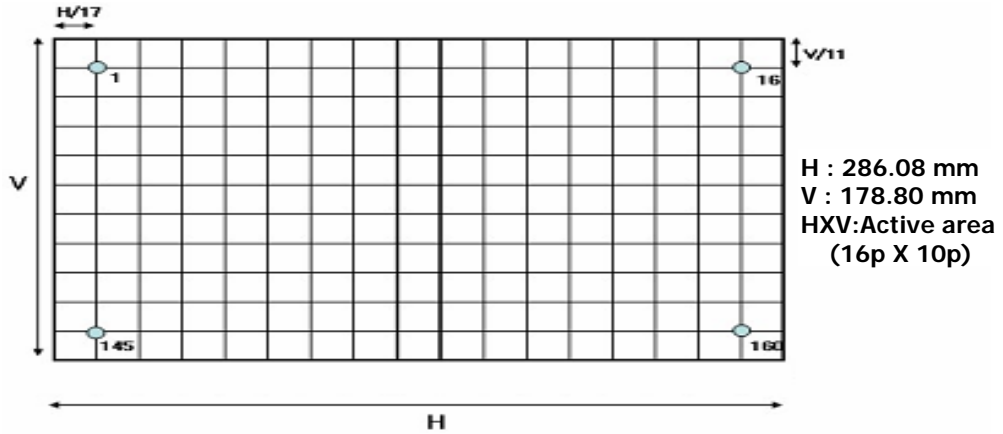

FIG. 3 Response Time

The response time is defined as the following figure and shall be measured by switching the input signal for "black" and "white".

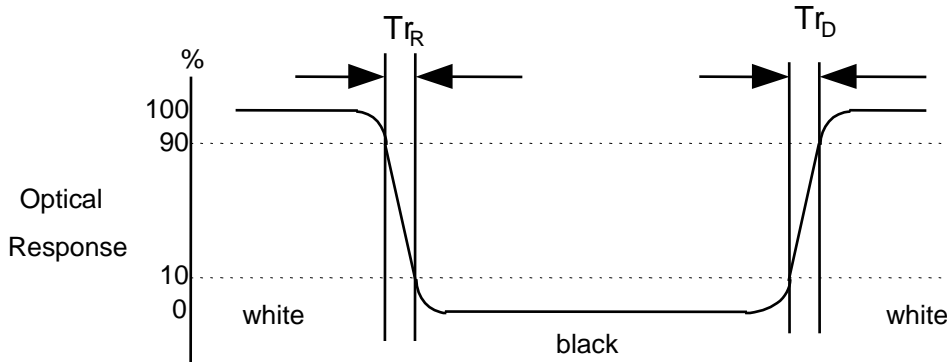
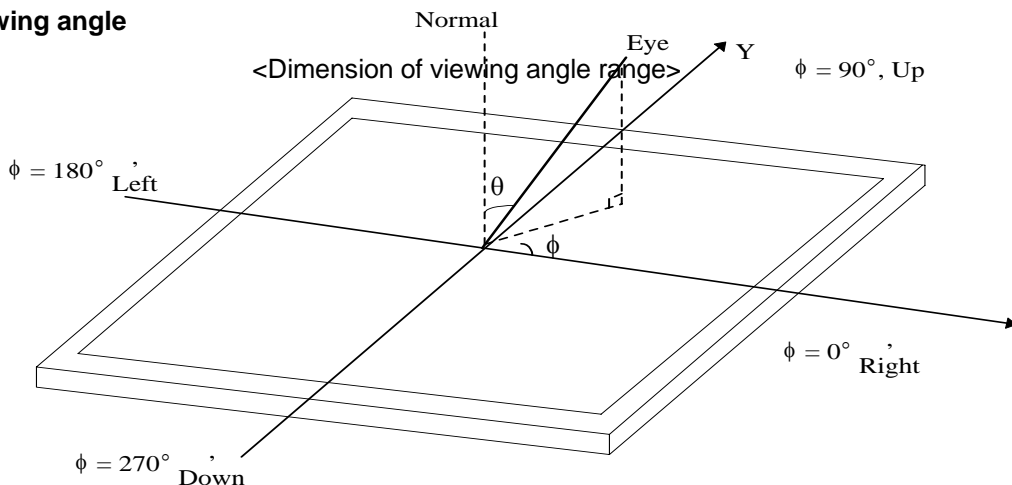

FIG. 4 Viewing angle



Product Specification

FIG. 5 Cross talk

No visual cross-talk will be allowed. Two luminance values are measured at center spot with 50 x 50 pixels. The cross-talk, D_{SHA} , is defined as,

$$D_{SHA} = (L_B - L_A) / L_B \cdot 100\%$$

Where, L_A = Luminance in Pattern A

L_B = Luminance in Pattern B.

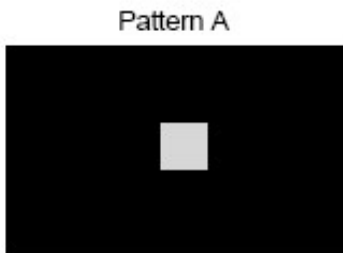

Pattern A
Gray Scale = 31 in center
Black in surrounding area

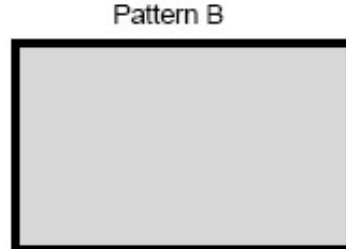

Pattern B
Gray Scale = 31 full screen

5. Mechanical Characteristics

The contents provide general mechanical characteristics for the model LP133WX2. In addition the figures in the next page are detailed mechanical drawing of the LCD.

Outline Dimension	Horizontal	297.15 ± 0.50mm
	Vertical	192.15 ± 0.50mm
	Thickness	3.6mm(Max.)
Bezel Area	Horizontal	289.48 mm
	Vertical	182.20mm
Active Display Area	Horizontal	286.08mm
	Vertical	178.80 mm
Weight	315g (Max.)	
Surface Treatment	Hard coating(2H), Glare treatment of the front Polarizer (Haze 0%)	

Product Specification

<FRONT VIEW>

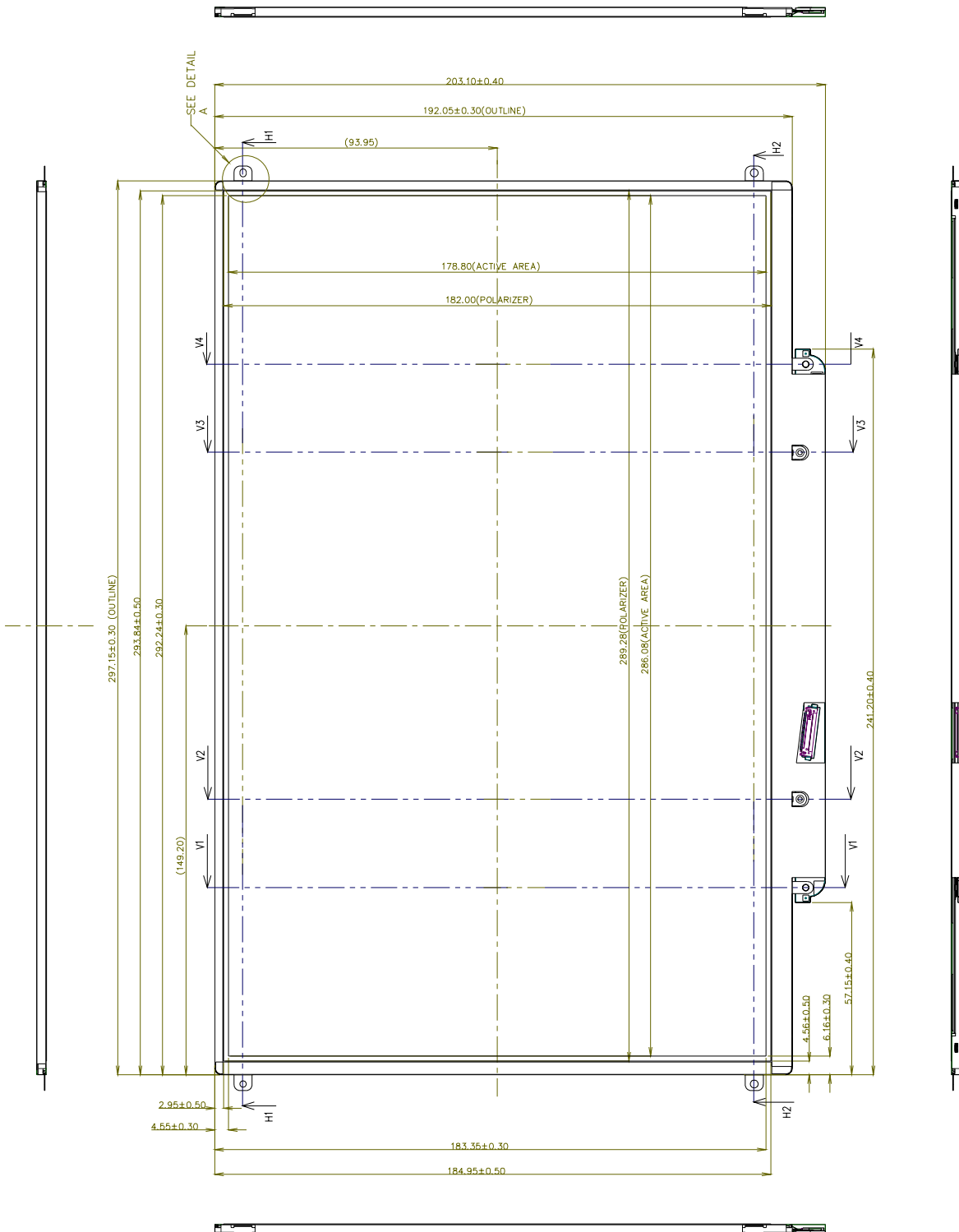

Product Specification

<REAR VIEW>

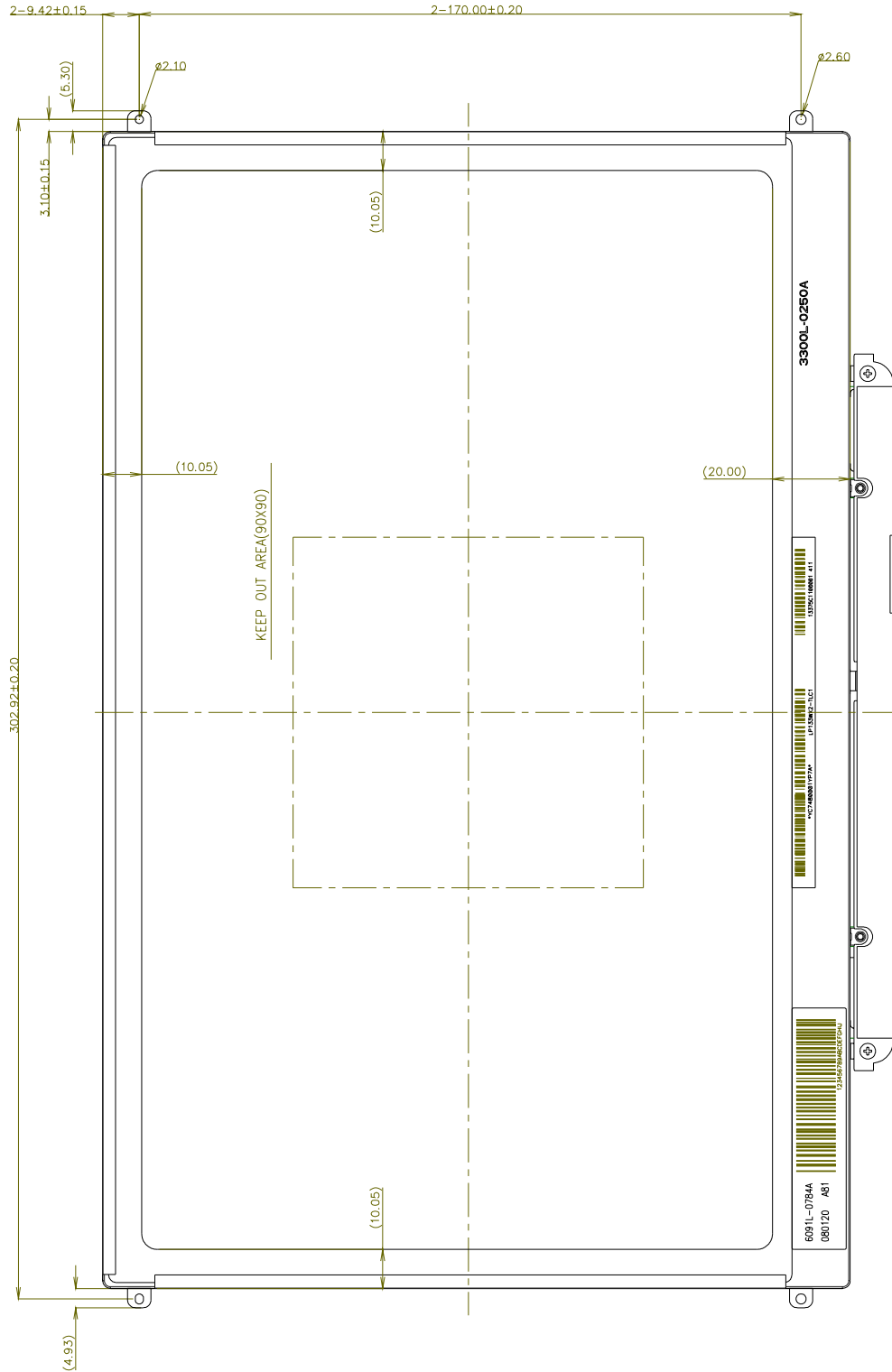

Product Specification

6. Reliability

Environment test condition

No.	Test Item	Conditions
1	High temperature storage test	Ta= 60°C, 240h
2	Low temperature storage test	Ta= -20°C, 240h
3	High temperature operation test	Ta= 50°C, 50%RH, 240h
4	Low temperature operation test	Ta= 0°C, 240h
5	Vibration test (non-operating)	Sine wave, 10 ~ 500 ~ 10Hz, 1.5G, 0.37oct/min 3 axis, 1hour/axis
6	Shock test (non-operating)	Half sine wave, 180G, 2ms one shock of each six faces(I.e. run 180G 6ms for all six faces)
7	Altitude operating storage / shipment	0 ~ 10,000 feet (3,048m) 24Hr 0 ~ 40,000 feet (12,192m) 24Hr

{ Result Evaluation Criteria }

There should be no change which might affect the practical display function when the display quality test is conducted under normal operating condition.

7. International Standards

7-1. Safety

- a) UL 60950-1:2003, First Edition, Underwriters Laboratories, Inc., Standard for Safety of Information Technology Equipment.
- b) CAN/CSA C22.2, No. 60950-1-03 1st Ed. April 1, 2003, Canadian Standards Association, Standard for Safety of Information Technology Equipment.
- c) EN 60950-1:2001, First Edition, European Committee for Electrotechnical Standardization(CENELEC) European Standard for Safety of Information Technology Equipment.

7-2. EMC

- a) ANSI C63.4 "Methods of Measurement of Radio-Noise Emissions from Low-Voltage Electrical and Electrical Equipment in the Range of 9kHz to 40GHz. "American National Standards Institute(ANSI), 1992
- b) C.I.S.P.R "Limits and Methods of Measurement of Radio Interface Characteristics of Information Technology Equipment." International Special Committee on Radio Interference.
- c) EN 55022 "Limits and Methods of Measurement of Radio Interface Characteristics of Information Technology Equipment." European Committee for Electrotechnical Standardization.(CENELEC), 1998 (Including A1: 2000)

Product Specification

8. Packing

8-1. Designation of Lot Mark

a) Lot Mark

A	B	C	D	E	F	G	H	I	J	K	L	M
---	---	---	---	---	---	---	---	---	---	---	---	---

A,B,C : SIZE(INCH)
E : MONTH

D : YEAR
F ~ M : SERIAL NO.

Note

1. YEAR

Year	2001	2002	2003	2004	2005	2006	2007	2008	2009	2010
Mark	1	2	3	4	5	6	7	8	9	0

2. MONTH

Month	Jan	Feb	Mar	Apr	May	Jun	Jul	Aug	Sep	Oct	Nov	Dec
Mark	1	2	3	4	5	6	7	8	9	A	B	C

b) Location of Lot Mark

Serial No. is printed on the label. The label is attached to the backside of the LCD module.
This is subject to change without prior notice.

8-2. Packing Form

a) Package quantity in one box : 20 pcs

b) Box Size : 482mm × 278mm × 383mm

9. PRECAUTIONS

Please pay attention to the followings when you use this TFT LCD module.

9-1. MOUNTING PRECAUTIONS

- (1) You must mount a module using holes arranged in four corners or four sides.
- (2) You should consider the mounting structure so that uneven force (ex. Twisted stress) is not applied to the module. And the case on which a module is mounted should have sufficient strength so that external force is not transmitted directly to the module.
- (3) Please attach the surface transparent protective plate to the surface in order to protect the polarizer. Transparent protective plate should have sufficient strength in order to resist external force.
- (4) You should adopt radiation structure to satisfy the temperature specification.
- (5) Acetic acid type and chlorine type materials for the cover case are not desirable because the former generates corrosive gas of attacking the polarizer at high temperature and the latter causes circuit break by electro-chemical reaction.
- (6) Do not touch, push or rub the exposed polarizers with glass, tweezers or anything harder than HB pencil lead. And please do not rub with dust clothes with chemical treatment. Do not touch the surface of polarizer for bare hand or greasy cloth.(Some cosmetics are detrimental to the polarizer.)
- (7) When the surface becomes dusty, please wipe gently with absorbent cotton or other soft materials like chamois soaks with petroleum benzene. Normal-hexane is recommended for cleaning the adhesives used to attach front / rear polarizers. Do not use acetone, toluene and alcohol because they cause chemical damage to the polarizer.
- (8) Wipe off saliva or water drops as soon as possible. Their long time contact with polarizer causes deformations and color fading.
- (9) Do not open the case because inside circuits do not have sufficient strength.

9-2. OPERATING PRECAUTIONS

- (1) The spike noise causes the mis-operation of circuits. It should be lower than following voltage :
 $V = \pm 200\text{mV}$ (Over and under shoot voltage)
- (2) Response time depends on the temperature.(In lower temperature, it becomes longer.)
- (3) Brightness depends on the temperature. (In lower temperature, it becomes lower.)
And in lower temperature, response time(required time that brightness is stable after turned on) becomes longer.
- (4) Be careful for condensation at sudden temperature change. Condensation makes damage to polarizer or electrical contacted parts. And after fading condensation, smear or spot will occur.
- (5) When fixed patterns are displayed for a long time, remnant image is likely to occur.
- (6) Module has high frequency circuits. Sufficient suppression to the electromagnetic interference shall be done by system manufacturers. Grounding and shielding methods may be important to minimize the interference.

Product Specification

9-3. ELECTROSTATIC DISCHARGE CONTROL

Since a module is composed of electronic circuits, it is not strong to electrostatic discharge. Make certain that treatment persons are connected to ground through wrist band etc. And don't touch interface pin directly.

9-4. PRECAUTIONS FOR STRONG LIGHT EXPOSURE

Strong light exposure causes degradation of polarizer and color filter.

9-5. STORAGE

When storing modules as spares for a long time, the following precautions are necessary.

- (1) Store them in a dark place. Do not expose the module to sunlight or fluorescent light. Keep the temperature between 5°C and 35°C at normal humidity.
- (2) The polarizer surface should not come in contact with any other object.
It is recommended that they be stored in the container in which they were shipped.

9-6. HANDLING PRECAUTIONS FOR PROTECTION FILM

- (1) When the protection film is peeled off, static electricity is generated between the film and polarizer.
This should be peeled off slowly and carefully by people who are electrically grounded and with well ion-blown equipment or in such a condition, etc.
- (2) The protection film is attached to the polarizer with a small amount of glue. If some stress is applied to rub the protection film against the polarizer during the time you peel off the film, the glue is apt to remain on the polarizer.
Please carefully peel off the protection film without rubbing it against the polarizer.
- (3) When the module with protection film attached is stored for a long time, sometimes there remains a very small amount of glue still on the polarizer after the protection film is peeled off.
- (4) You can remove the glue easily. When the glue remains on the polarizer surface or its vestige is recognized, please wipe them off with absorbent cotton waste or other soft material like chamois soaked with normal-hexane.

APPENDIX A. Enhanced Extended Display Identification Data (EEDID™) 1/3

TBD

APPENDIX A. Enhanced Extended Display Identification Data (EEDID™) 2/3

TBD

APPENDIX A. Enhanced Extended Display Identification Data (EEDID™) 3/3

TBD