

Product Specification

**1. General Description**

The LP121X04(B2) is a Color Active Matrix Liquid Crystal Display with an integral Cold Cathode Fluorescent Lamp(CCFL) backlight system. The matrix employs a-Si Thin Film Transistor as the active element. It is a transmissive type display operating in the normally white mode. This TFT-LCD has 12.1 inches diagonally measured active display area with XGA resolution(768 vertical by 1024 horizontal pixel array) Each pixel is divided into Red, Green and Blue sub-pixels or dots which are arranged in vertical stripes. Gray scale or the brightness of the sub-pixel color is determined with a 6-bit gray scale signal for each dot, thus, presenting a palette of more than 262,144 colors.

The LP121X04(B2) has been designed to apply the interface method that enables low power, high speed, low EMI. Flat Link must be used as a LVDS(Low Voltage Differential Signaling) chip.

The LP121X04(B2) is intended to support applications where thin thickness, low power are critical factors and graphic display are important. In combination with the vertical arrangement of the sub-pixels, the LP121X04(B2) characteristics provide an excellent flat display for office automation products such as Notebook PC.

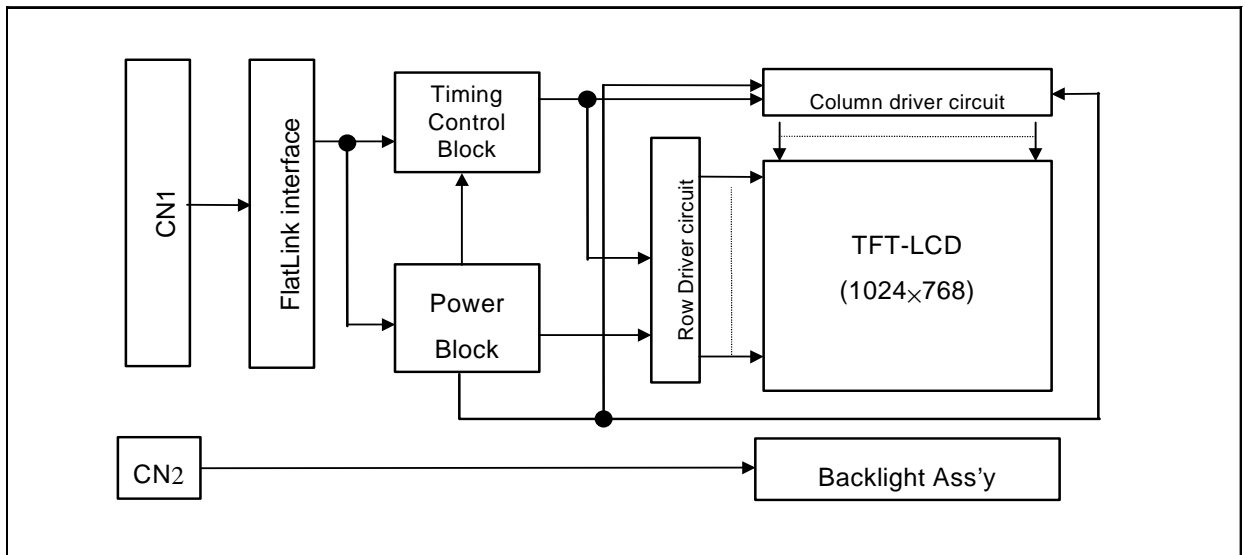

**General Features**

Active screen size	12.1 inches(30.73cm) diagonal
Outline Dimension	261(H) x 199(V) x 5.0(D) mm(Typ.)
Pixel Pitch	0.240 mm x 0.240mm
Pixel format	1024 horiz. By 768 vert. Pixels RGB stripes arrangement
Color depth	6-bit, 262,144 colors
Luminance, white	150 cd/m <sup>2</sup> (Typ.) , center 1point @ 5.5mA
Power Consumption	Total 4.5 Watt(Typ.)
Weight	300g(Typ.)
Display operating mode	Transmissive mode, normally white
Surface treatments	Hard coating(3H) Anti-glare treatment of the both(front,back) polarizer, HAZE(44%,12%)

Product Specification

**2. Electrical Specifications**

The LP121X04(B2) requires two power inputs. One is employed to power the LCD electronics and to drive the TFT array and liquid crystal. The second input which powers the CCFL, is typically generated by an inverter. The inverter is an external unit to the LCD.

**Table 1. ELECTRICAL CHARACTERISTICS**

Parameter	Symbol	Values			Units	Notes
		Min.	Typ.	Max.		
<b>MODULE :</b>						
Power Supply Input Voltage	$V_{CC}$	3.0	3.3	3.6	Vdc	
Power Supply Input Current	$I_{CC}$	-	0.263	0.302	A	1
Differential Impedance	$Z_m$	90	100	110	ohm	2
Power Consumption	$P_C$	-	0.87	1.00	Watts	1
Rush Current	$I_{RUSH}$		1.0	1.8	A	3
<b>LAMP :</b>						
Operating Voltage	$V_{BL}$	-	580	640	$V_{RMS}$	4
Operating Current	$I_{BL}$	3.0	5.5	6.0	mA	
Established Starting Voltage	$V_S$					5
at 25 °C		-	-	1010	$V_{RMS}$	
at 0 °C		-	-	1210	$V_{RMS}$	
Operating Frequency	$f_{BL}$	50	65	80	kHz	4
Discharge Stabilization Time	$T_S$			3	Minutes	5
Power Consumption	$P_{BL}$	-	3.2	3.52	Watts	6
Life Time		10,000	-	-	Hrs	7

Note : **The design of the inverter must have specification for the lamp in LCD Assembly.**

The performance of the Lamp in LCM, for example life time or brightness, is extremely influenced by the characteristics of the DC-AC inverter. So all the parameters of an inverter should be carefully designed so as not to produce too much leakage current from high-voltage output of the inverter.

When you design or order the inverter, please make sure unwanted lighting caused by the mismatch of the lamp and the inverter(no lighting, flicker, etc) never occurs. When you confirm it, the LCD Assembly should be operated in the same condition as installed in you instrument.

1. The specified current and power consumption are under the  $V_{CC}=3.3V$ ,  $25^{\circ}C$ ,  $f_v=60Hz$  condition whereas full black pattern is displayed and  $f_v$  is the frame frequency.
2. This impedance value is needed to proper display and measured from LVDS  $T_x$  to the mating connector.
3. The duration of rush current is about 20ms.
4. The variance of the voltage is  $\pm 10\%$ .
5. The voltage above  $V_S$  should be applied to the lamps for more than 1 second for start-up. Otherwise, the lamps may not be turned on.

## Product Specification

6. The output of the inverter must have symmetrical(negative and positive) voltage waveform and symmetrical current waveform.(Asymmetrical ratio is less than 10%) Please do not use the inverter which has asymmetrical voltage and asymmetrical current and spike wave.  
Lamp frequency may produce interface with horizontal synchronous frequency and as a result this may cause beat on the display. Therefore lamp frequency shall be as away possible from the horizontal synchronous frequency and from its harmonics in order to prevent interference.
7. It is defined the brightness of the lamp after being lighted for 5 minutes as 100%.  
 $T_S$  is the time required for the brightness of the center of the lamp to be not less than 95%.
8. The lamp power consumption shown above does not include loss of external inverter.  
The used lamp current is the lamp typical current.
9. The life is determined as the time at which brightness of the lamp is 50% compared to that of initial value at the typical lamp current on condition of continuous operating at  $25 \pm 2^\circ\text{C}$ .
10. Do not attach a conducting tape to lamp connecting wire.  
If the lamp wire attach to a conducting tape, TFT-LCD Module has a low luminance and the inverter has abnormal action. Because leakage current is occurred between lamp wire and conducting tape.

Product Specification

### 3. Interface Connections

Interface chip must be used FlatLink, part No. SN75LVDS84(Transmitter made by Texas Instrument Inc or equivalence.

This LCD employs two interface connections, a 20 pin connector is used for the module electronics and the other connector is used for the integral backlight system.

The electronics interface connector is a model DF19K-20P-1H manufactured by Hirose or equivalent.

The pin configuration for the connector is shown in the table below.

**Table 2. MODULE CONNECTOR PIN CONFIGURATION(LVDS)**

Pin	Symbol	Description	Notes
1	Vcc	Power(3.3V)	1. Interface chips 1.1 LCD : LPZ4E102S6L(LCD Controller) including LVDS Receiver 1.2 System : SN75LVDS84 or equivalent *Pin to Pin compatible with Thine LVDS  2. Connector 2.1 LCD : DF19K-20P-1H,HIROSE or equivalent 2.2 Mating : DF19G-20S-1C or equivalent. 2.3 Connector pin arrangement
2	Vcc	Power(3.3V)	
3	GND	Ground	
4	GND	Ground	
5	A1M	Differential Signal	
6	A1P	Differential Signal	
7	GND	Ground	
8	A2M	Differential Signal	
9	A2P	Differential Signal	
10	GND	Ground	
11	A3M	Differential Signal	
12	A3P	Differential Signal	
13	GND	Ground	
14	CLKM	Differential Signal	
15	CLKP	Differential Signal	
16	GND	Ground	
17	NC	No Connection	
18	NC	No Connection	
19	GND	Ground	
20	GND	Ground	

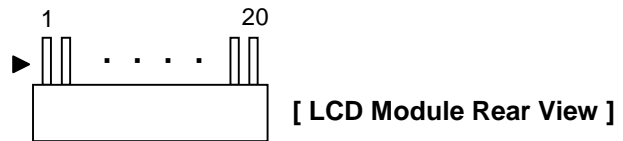

The backlight interface connector is a model BHSR-02VS-1, manufactured by JST. The mating connector part number is SM02B-BHSS-1 or equivalent.

The pin configuration for the connector is shown in the table below.

**Table 3. BACKLIGHT CONNECTOR PIN CONFIGURATION**

Pin	Symbol	Description	Notes
1	HV	Power supply for lamp (High voltage side)	1
2	LV	Power supply for lamp (Low voltage side)	1

Notes : 1. The high voltage side terminal is colored pink. The low voltage side terminal is white

Product Specification

<FRONT VIEW>

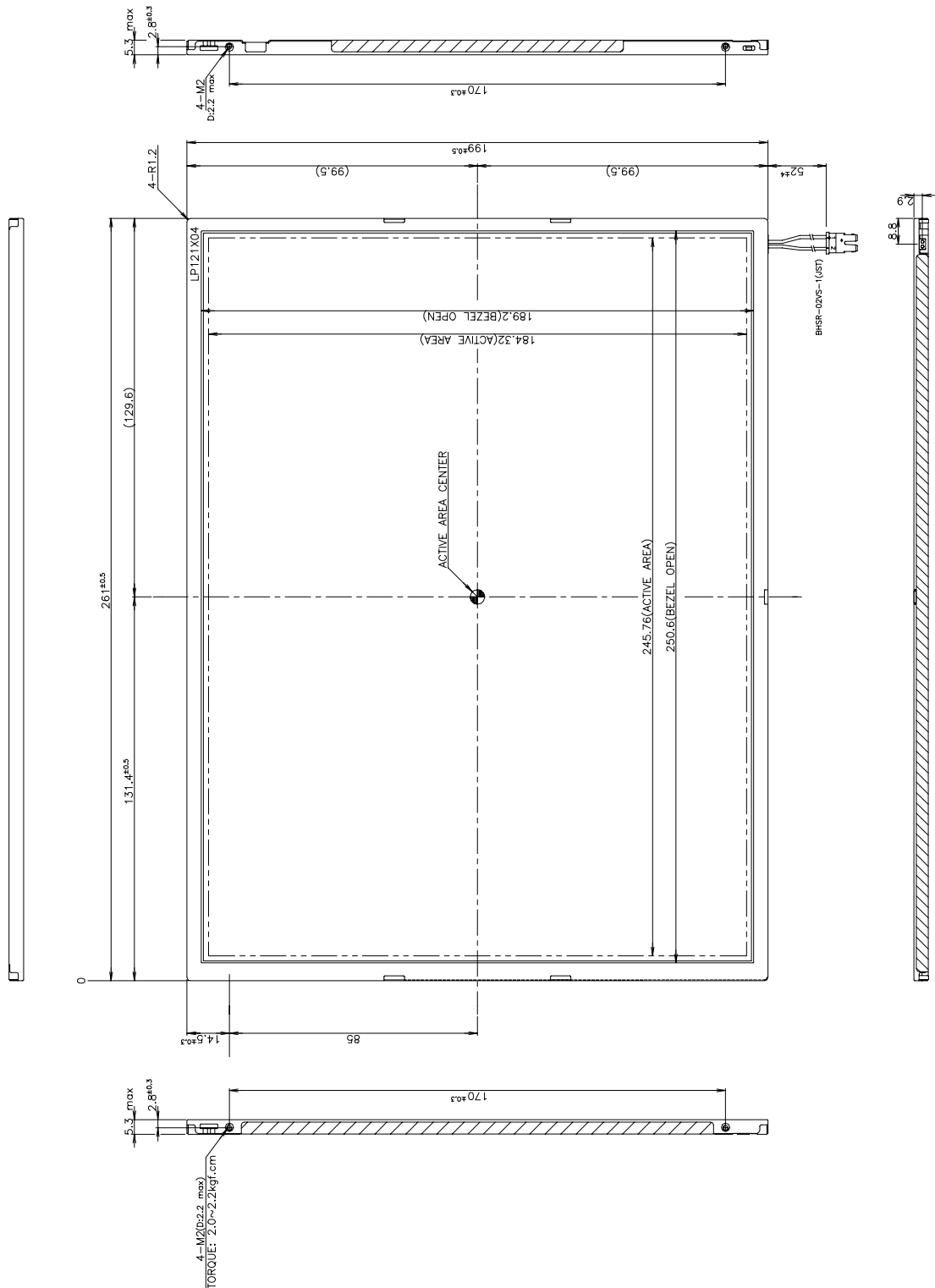

**Product Specification**

<REAR VIEW>

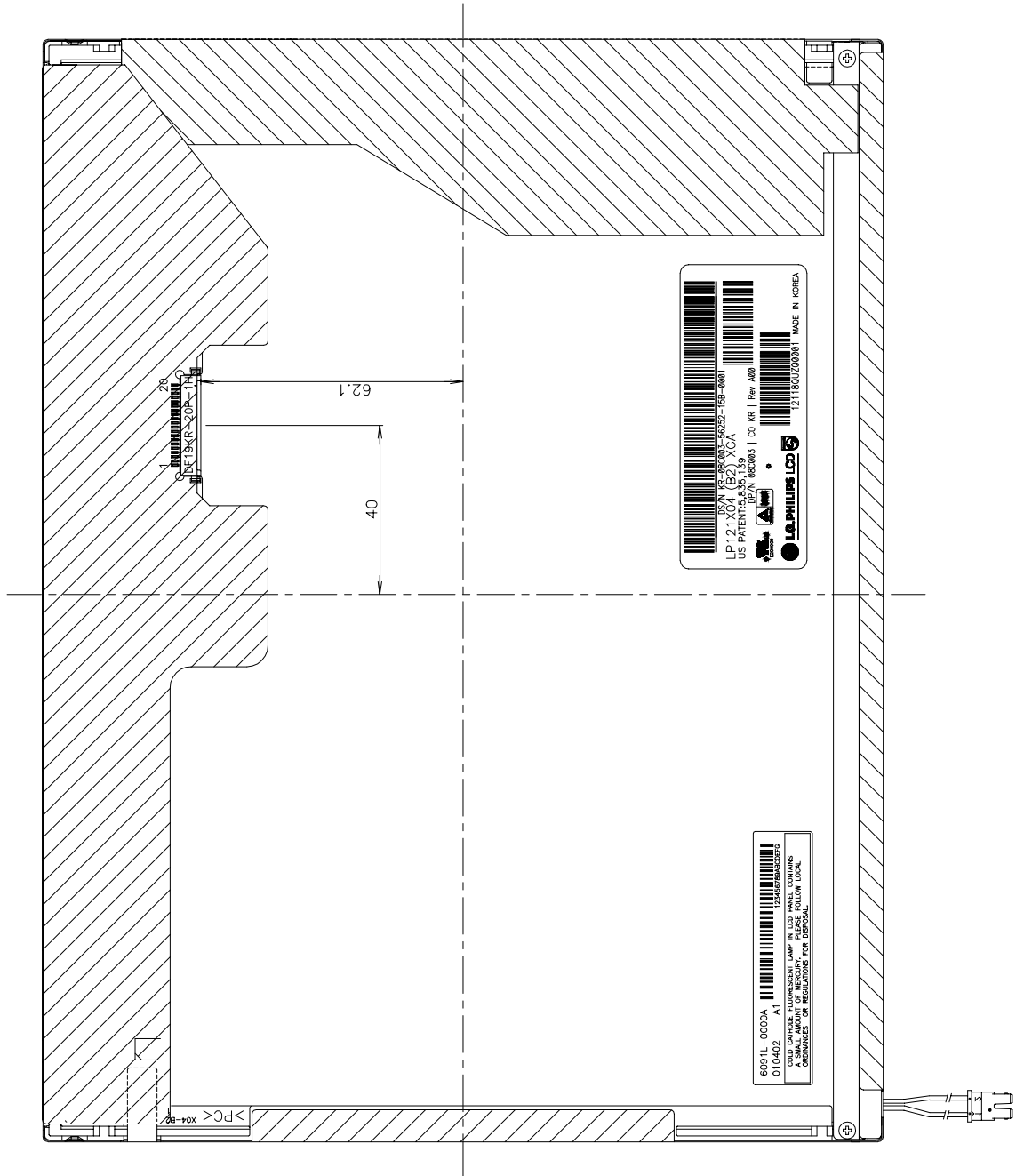

## Product Specification

**4. PRECAUTIONS**

The LCD Products listed on this documents are not suitable for use of Military, Industry, Medical etc. System.

If customers intend to use these LCD products for above application, Please contact our sales people In advance.