

Product Specification

# SPECIFICATION FOR APPROVAL

- ( ) Preliminary Specification
- ( ● ) Final Specification

|       |                   |
|-------|-------------------|
| Title | 26" WUXGA TFT LCD |
|-------|-------------------|



|       |  |
|-------|--|
| BUYER |  |
| MODEL |  |

|          |                          |
|----------|--------------------------|
| SUPPLIER | LG.Philips LCD Co., Ltd. |
| *MODEL   | LM260WU1                 |
| SUFFIX   | SLB1                     |

\*When you obtain standard approval,  
please use the above model name without suffix

| APPROVED BY | SIGNATURE<br>DATE |
|-------------|-------------------|
| /           |                   |
| /           |                   |
| /           |                   |

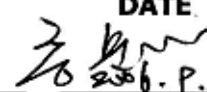
Please return 1 copy for your confirmation with your signature and comments.

| APPROVED BY          | SIGNATURE<br>DATE   |
|----------------------|---|
| S.G Hong / G.Manager | <br>2006.8.8   |
| REVIEWED BY          |   |
| C. K Lee / S.Manager | <br>2006.8.8   |
| PREPARED BY          |   |
| D.I.Chung / Manager  | <br>2006.08.08 |

**MNT Products Engineering Dept.**  
**LG. Philips LCD Co., Ltd**

Product Specification

Contents

| No  | ITEM                         | Page |
|-----|------------------------------|------|
|     | COVER                        | 1    |
|     | CONTENTS                     | 2    |
|     | RECORD OF REVISIONS          | 3    |
| 1   | GENERAL DESCRIPTION          | 4    |
| 2   | ABSOLUTE MAXIMUM RATINGS     | 5    |
| 3   | ELECTRICAL SPECIFICATIONS    | 6    |
| 3-1 | ELECTRICAL CHARACTERISTICS   | 6    |
| 3-2 | INTERFACE CONNECTIONS        | 8    |
| 3-3 | SIGNAL TIMING SPECIFICATIONS | 12   |
| 3-4 | SIGNAL TIMING WAVEFORMS      | 13   |
| 3-5 | COLOR INPUT DATA REFERENCE   | 14   |
| 3-6 | POWER SEQUENCE               | 15   |
| 4   | OPTICAL SPECIFICATIONS       | 17   |
| 5   | MECHANICAL CHARACTERISTICS   | 23   |
| 6   | RELIABILITY                  | 26   |
| 7   | INTERNATIONAL STANDARDS      | 27   |
| 7-1 | SAFETY                       | 27   |
| 7-2 | EMC                          | 27   |
| 8   | PACKING                      | 28   |
| 8-1 | DESIGNATION OF LOT MARK      | 28   |
| 8-2 | PACKING FORM                 | 28   |
| 9   | PRECAUTIONS                  | 29   |



**Product Specification**

**1. General Description**

LM260WU1 is a Color Active Matrix Liquid Crystal Display with an integral Cold Cathode Fluorescent Lamp(CCFL) backlight system. The matrix employs a-Si Thin Film Transistor as the active element. It is a transmissive type display operating in the normally black mode. It has a 25.54 inch diagonally measured active display area with WUXGA resolution (1200 vertical by 1920 horizontal pixel array) Each pixel is divided into Red, Green and Blue sub-pixels or dots which are arranged in vertical stripes. Gray scale or the brightness of the sub-pixel color is determined with a 8-bit gray scale signal for each dot, thus, presenting a palette of more than 16,7M(True) colors. It has been designed to apply the 8Bit 2 port LVDS interface. It is intended to support displays where high brightness, super wide viewing angle, high color saturation, and high color are important.

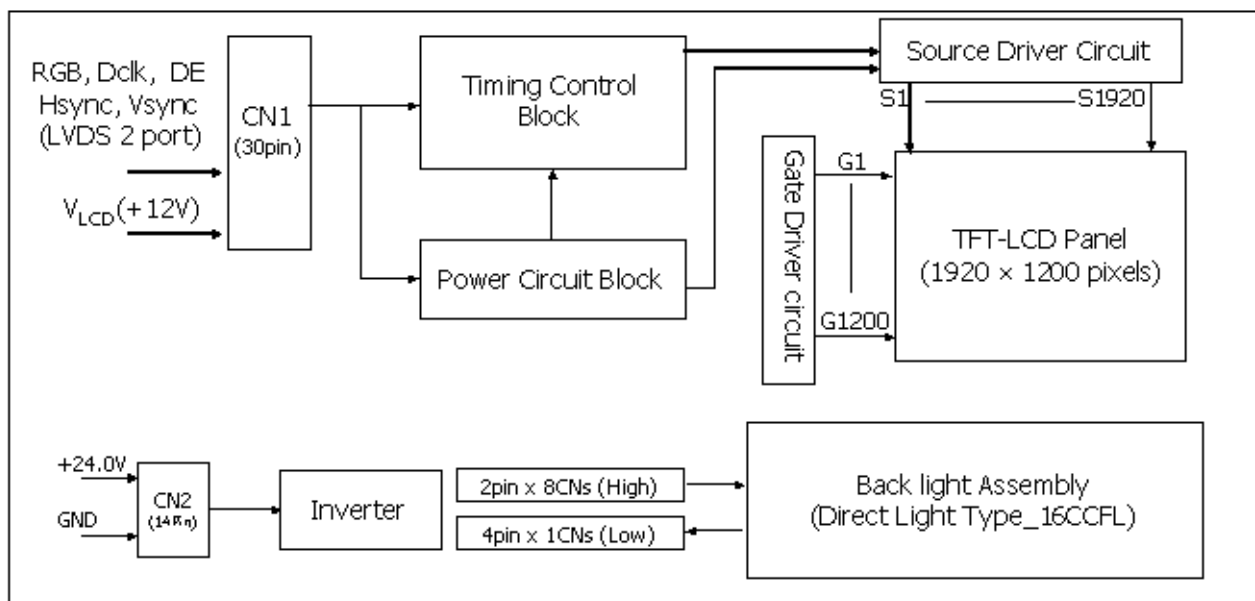

**General Features**

|                        |  |
|------------------------|--|
| Active Screen Size     | 25.54 inches(64.87cm) diagonal   |
| Outline Dimension      | 582(H) × 375.6(V) × 41.5(D) mm(Typ.)   |
| Pixel Pitch            | 0.2865 mm × 0.2865 mm  |
| Pixel Format           | 1920 horiz. By 1200 vert. Pixels RGB stripes arrangement   |
| Color Depth            | 8-bit, 16,777,216 colors   |
| Luminance, White       | 500 cd/m <sup>2</sup> (Center 1 point)   |
| Viewing Angle(CR> 10)  | View Angle Free (R/L 178(Typ.), U/D 178(Typ.))   |
| Power Consumption      | Total <b>86.96</b> Watt (Typ.) ( <b>6.96</b> Watt @V <sub>LC</sub> , 80 Watt @500cd/m <sup>2</sup> ) |
| Weight                 | 3,520 g(typ.)  |
| Display Operating Mode | Transmissive mode, normally black  |
| Surface Treatment      | Hard coating(3H), Anti-glare treatment of the front polarizer  |

**Product Specification**

**2. Absolute Maximum Ratings**

The following are maximum values which, if exceeded, may cause faulty operation or damage to the unit.

**Table 1. ABSOLUTE MAXIMUM RATINGS**

| Parameter                  | Symbol           | Values |     | Units | Notes       |
|----------------------------|------------------|--------|-----|-------|-------------|
|                            |                  | Min    | Max |       |             |
| Power Input Voltage        | V <sub>LCD</sub> | -0.3   | 14  | Vdc   | at 25 ± 2°C |
| Operating Temperature      | T <sub>OP</sub>  | 0      | 50  | °C    | 1           |
| Storage Temperature        | T <sub>ST</sub>  | -20    | 60  | °C    |             |
| Operating Ambient Humidity | H <sub>OP</sub>  | 10     | 90  | %RH   |             |
| Storage Humidity           | H <sub>ST</sub>  | 10     | 90  | %RH   |             |

Note : 1. Temperature and relative humidity range are shown in the figure below.  
Wet bulb temperature should be 39 °C Max., and no condensation of water.

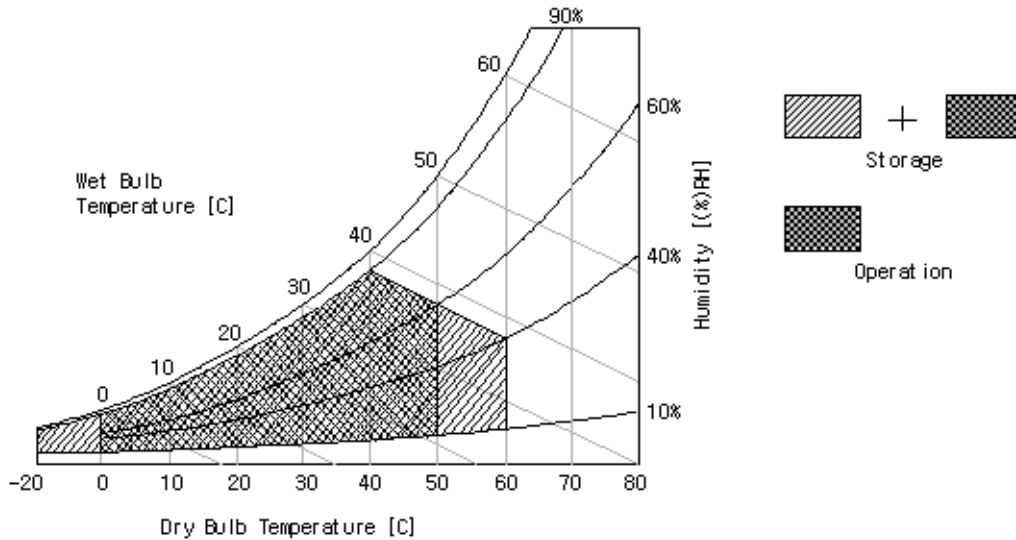

Product Specification

### 3. Electrical Specifications

#### 3-1. Electrical Characteristics

It requires two power inputs. One is employed to power the LCD electronics and to drive the TFT array and liquid crystal. The second input power for the CCFL, is typically generated by an inverter. The inverter is an external unit to the LCDs.

Table 2-1. ELECTRICAL CHARACTERISTICS

| Parameter                     | Symbol            | Values |      |      | Unit              | Notes |
|-------------------------------|-------------------|--------|------|------|-------------------|-------|
|                               |                   | Min    | Typ  | Max  |                   |       |
| MODULE :                      |                   |        |      |      |                   |       |
| Power Supply Input Voltage    | V <sub>LCD</sub>  | 11.4   | 12.0 | 12.6 | Vdc               |       |
| Permissive Power Input Ripple | V <sub>dRF</sub>  |        |      | 400  | mV <sub>p-p</sub> |       |
| Power Supply Input Current    | I <sub>LCD</sub>  | -      | 580  | 667  | mA                | 1     |
|                               |                   | -      | 790  | 909  | mA                | 2     |
| Power Consumption             | P <sub>LCD</sub>  | -      | 6.96 | 8.00 | Watt              | 1     |
| Rush current                  | I <sub>RUSH</sub> | -      | -    | 3.0  | A                 | 3     |

Note :

1. The specified current and power consumption are under the V<sub>LCD</sub>=12.0V, 25 ± 2°C, f<sub>v</sub>=60Hz condition whereas mosaic pattern(8 × 6) is displayed and f<sub>v</sub> is the frame frequency.
2. The current is specified at the maximum current pattern.
3. The duration of rush current is about 2ms and rising time of power Input is 1ms(min.).

White : 255Gray  
Black : 0Gray

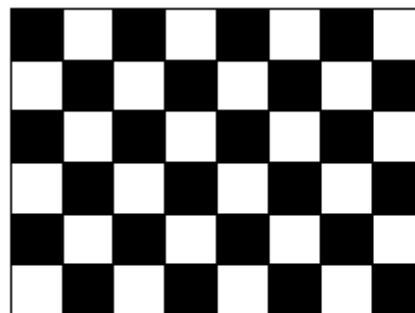

Mosaic Pattern(8 × 6)

Product Specification

Table 2-2. INVERTER ELECTRICAL CHARACTERISTICS

| Parameter          | Symbol       | Condition       | Values |      |      | Unit | Notes |
|--------------------|--------------|-----------------|--------|------|------|------|-------|
|                    |              |                 | Min.   | Typ. | Max. |      |       |
| <b>Inverter :</b>  |              |                 |        |      |      |      |       |
| Input Voltage      | $V_{DDB}$    |                 | 22     | 24.0 | 26   | V    | 1     |
| Input Current      | $I_{DDB}$    | $V_{BR} = 3.3V$ | -      | 3.35 | 4.02 | A    | 2     |
| Input Power        | $P_B$        | $V_{BR} = 3.3V$ | -      | 80   | 96   | Watt | 2     |
| B/L on/off control | $V_{ON/OFF}$ | Lamp ON = High  | 2.0    | -    | 5.0  | V    |       |
|                    |              | Lamp OFF =Low   | 0.0    | -    | 0.8  | V    |       |
| Brightness Adj     | $V_{BR}$     |                 | 0      | -    | 3.3  | V    |       |
| <b>LAMP :</b>      |              |                 |        |      |      |      |       |
| Life time          |              |                 | 40,000 |      |      | Hrs  | 3     |

Notes :

1. The input voltage ripple is limited below 400mVp-p.
2. The specified current and power consumption are under the typical supply Input voltage, 24V.
3. The life is determined as the time at which luminance of the lamp is 50% compared to that of initial value at the typical lamp current on condition of continuous operating at  $25 \pm 2^\circ\text{C}$ .
4. Electrical characteristics are determined after the unit has been 'ON' and stable for approximately 30min in a dark environment at  $25^\circ\text{C} \pm 2^\circ\text{C}$ .

**Product Specification**

**3-2. Interface Connections**

This LCD employs Two interface connections, a 30 pin connector is used for the module electronics and a 14Pin Connector is used for the integral backlight system.

**3-2-1. LCD Module**

- LCD Connector(CN1): KDF71G-30S-1H, (Manufactured by Hirose )
- Mating Connector : FI-X30C2L (Manufactured by JAE) or Equivalent

**Table 3 MODULE CONNECTOR(CN1) PIN CONFIGURATION**

| No | Symbol | Description                              | No | Symbol           | Symbol                                    |
|----|--------|--|----|------------------|---|
| 1  | FR0M   | Minus signal of odd channel 0 (LVDS)     | 16 | SR1P             | Plus signal of even channel 1 (LVDS)      |
| 2  | FR0P   | Plus signal of odd channel 0 (LVDS)      | 17 | GND              | Ground                                    |
| 3  | FR1M   | Minus signal of odd channel 1 (LVDS)     | 18 | SR2M             | Minus signal of even channel 2 (LVDS)     |
| 4  | FR1P   | Plus signal of odd channel 1 (LVDS)      | 19 | SR2P             | Plus signal of even channel 2 (LVDS)      |
| 5  | FR2M   | Minus signal of odd channel 2 (LVDS)     | 20 | SCLKIM           | Minus signal of even clock channel (LVDS) |
| 6  | FR2P   | Plus signal of odd channel 2 (LVDS)      | 21 | SCLKIP           | Plus signal of even clock channel (LVDS)  |
| 7  | GND    | Ground                                   | 22 | SR3M             | Minus signal of even channel 3 (LVDS)     |
| 8  | FCLKIM | Minus signal of odd clock channel (LVDS) | 23 | SR3P             | Plus signal of even channel 3 (LVDS)      |
| 9  | FCLKIP | Plus signal of odd clock channel (LVDS)  | 24 | GND              | Ground                                    |
| 10 | FR3M   | Minus signal of odd channel 3 (LVDS)     | 25 | NC               | No Connection                             |
| 11 | FR3P   | Plus signal of odd channel 3 (LVDS)      | 26 | NC               | No Connection                             |
| 12 | SR0M   | Minus signal of even channel 0 (LVDS)    | 27 | DCR_OUT          | Dynamic C/R output                        |
| 13 | SR0P   | Plus signal of even channel 0 (LVDS)     | 28 | NC               | No Connection                             |
| 14 | GND    | Ground                                   | 29 | V <sub>LOD</sub> | Power Supply +12,0V                       |
| 15 | SR1M   | Minus signal of even channel 1 (LVDS)    | 30 | V <sub>LOD</sub> | Power Supply +12,0V                       |

- Note:
1. All GND(ground) pins should be connected together and to V<sub>SS</sub> which should also be connected to the LCD's metal frame.
  2. All V<sub>LOD</sub> (power input) pins should be connected together.
  3. Input Level of LVDS signal is based on the IEA 664 Standard.

**Rear view of LCM**

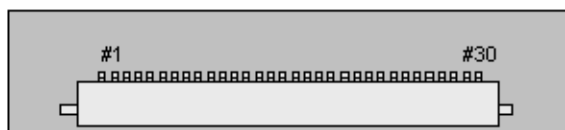

**KDF71G-30S-1H**





**Product Specification**
**Table 4. REQUIRED SIGNAL ASSIGNMENT FOR Flat Link (TI:SN75LVDS83) Transmitter**

| Pin # | Pin Name | Require Signal             | Pin # | Pin Name                | Require Signal                           |
|-------|----------|----------------------------|-------|-------------------------|--|
| 1     | Vcc      | Power Supply for TTL Input | 29    | GND                     | Ground pin for TTL                       |
| 2     | D5       | TTL Input (R7)             | 30    | D26                     | TTL Input (DE)                           |
| 3     | D6       | TTL Input (R5)             | 31    | T <sub>x</sub> CLKIN    | TTL Level clock Input                    |
| 4     | D7       | TTL Input (G0)             | 32    | PWR DWN                 | Power Down Input                         |
| 5     | GND      | Ground pin for TTL         | 33    | PLL GND                 | Ground pin for PLL                       |
| 6     | D8       | TTL Input (G1)             | 34    | PLL Vcc                 | Power Supply for PLL                     |
| 7     | D9       | TTL Input (G2)             | 35    | PLL GND                 | Ground pin for PLL                       |
| 8     | D10      | TTL Input (G6)             | 36    | LVDS GND                | Ground pin for LVDS                      |
| 9     | Vcc      | Power Supply for TTL Input | 37    | T <sub>x</sub> OUT3 +   | Positive LVDS differential data output 3 |
| 10    | D11      | TTL Input (G7)             | 38    | T <sub>x</sub> OUT3 -   | Negative LVDS differential data output 3 |
| 11    | D12      | TTL Input (G3)             | 39    | T <sub>x</sub> CLKOUT + | Positive LVDS differential clock output  |
| 12    | D13      | TTL Input (G4)             | 40    | T <sub>x</sub> CLKOUT - | Negative LVDS differential clock output  |
| 13    | GND      | Ground pin for TTL         | 41    | T <sub>x</sub> OUT2 +   | Positive LVDS differential data output 2 |
| 14    | D14      | TTL Input (G5)             | 42    | T <sub>x</sub> OUT2 -   | Negative LVDS differential data output 2 |
| 15    | D15      | TTL Input (B0)             | 43    | LVDS GND                | Ground pin for LVDS                      |
| 16    | D16      | TTL Input (B6)             | 44    | LVDS Vcc                | Power Supply for LVDS                    |
| 17    | Vcc      | Power Supply for TTL Input | 45    | T <sub>x</sub> OUT1 +   | Positive LVDS differential data output 1 |
| 18    | D17      | TTL Input (B7)             | 46    | T <sub>x</sub> OUT1 -   | Negative LVDS differential data output 1 |
| 19    | D18      | TTL Input (B1)             | 47    | T <sub>x</sub> OUT0 +   | Positive LVDS differential data output 0 |
| 20    | D19      | TTL Input (B2)             | 48    | T <sub>x</sub> OUT0 -   | Negative LVDS differential data output 0 |
| 21    | GND      | Ground pin for TTL Input   | 49    | LVDS GND                | Ground pin for LVDS                      |
| 22    | D20      | TTL Input (B3)             | 50    | D27                     | TTL Input (R6)                           |
| 23    | D21      | TTL Input (B4)             | 51    | D0                      | TTL Input (R0)                           |
| 24    | D22      | TTL Input (B5)             | 52    | D1                      | TTL Input (R1)                           |
| 25    | D23      | TTL Input (RSVD)           | 53    | GND                     | Ground pin for TTL                       |
| 26    | Vcc      | Power Supply for TTL Input | 54    | D2                      | TTL Input (R2)                           |
| 27    | D24      | TTL Input (HSYNC)          | 55    | D3                      | TTL Input (R3)                           |
| 28    | D25      | TTL Input (VSYNC)          | 56    | D4                      | TTL Input (R4)                           |

Notes : Refer to LVDS Transmitter Data Sheet for detail descriptions.

**Product Specification**

**3-2-2. Backlight Interface**

- Inverter Connector : S14B-PHA-SM3 Side entry type (Manufactured by JST) or Equivalent
- Mating Connector : PHR-14(Manufactured by JST) or Equivalent

**Table 4. INVERTER CONNECTOR PIN CONFIGURATION**

| Pin No | Symbol          | Description                   | Remarks                     |
|--------|-----------------|-------------------------------|-----------------------------|
| 1      | V <sub>BL</sub> | Power Supply +24.0V           |                             |
| 2      | V <sub>BL</sub> | Power Supply +24.0V           |                             |
| 3      | V <sub>BL</sub> | Power Supply +24.0V           |                             |
| 4      | V <sub>BL</sub> | Power Supply +24.0V           |                             |
| 5      | V <sub>BL</sub> | Power Supply +24.0V           |                             |
| 6      | GND             | Power Ground                  | Note 1                      |
| 7      | GND             | Power Ground                  |                             |
| 8      | GND             | Power Ground                  |                             |
| 9      | GND             | Power Ground                  |                             |
| 10     | GND             | Power Ground                  |                             |
| 11     | OPEN            | NC                            |                             |
| 12     | V <sub>ON</sub> | Backlight On/off Signal       | (On :2.0V~5V/Off :0.0~0.8V) |
| 13     | V <sub>BR</sub> | Brightness Adjustable Voltage | (Max :3.3V / Min :0.0V)     |
| 14     | OPEN            | NC                            |                             |

Notes : 1. GND is connected to the LCD's metal frame.

**Rear view of LCM**

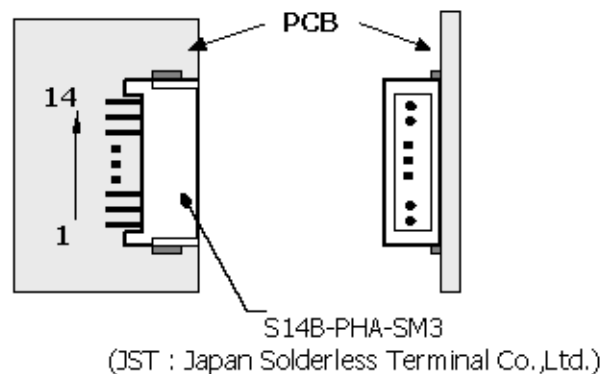

Product Specification

### 3-3. Signal Timing Specifications

This is signal timing required at the input of the TMDS transmitter. All of the interface signal timing should be satisfied with the following specifications for it's proper operation.

**Table 5. TIMING TABLE (VESA COORDINATED VIDEO TIMING)**

| ITEM   |                        | SYMBOL | Min   | Typ   | Max  | Unit | Note              |
|--------|------------------------|--------|-------|-------|------|------|-------------------|
| DCLK   | Period                 | tCLK   | 6.58  | 6.49  | 6.41 | ns   |                   |
|        | Frequency              | fCLK   | 152   | 154   | 156  | MHz  |                   |
| Hsync  | Period                 | tHP    | 2072  | 2080  | 2088 | tCLK |                   |
|        | Width-Active           | tWH    | 32    | 32    | 32   |      |                   |
| Vsync  | Period                 | tVP    | 1233  | 1235  | 1237 | tHP  |                   |
|        | Frequency              | fV     | 58.85 | 59.95 | 61   | Hz   |                   |
|        | Width-Active           | tWV    | 6     | 6     | 6    | tHP  |                   |
| Data   | Horizontal Valid       | tHV    | 1920  | 1920  | 1920 | tCLK |                   |
|        | Horizontal Back Porch  | tHBP   | 72    | 80    | 88   |      |                   |
|        | Horizontal Front Porch | tHFP   | 40    | 48    | 56   |      |                   |
|        | Horizontal Blank       | -      | 152   | 160   | 168  |      | tWH + tHBP + tHFP |
| Enable | Vertical Valid         | tVW    | 1200  | 1200  | 1200 | tHP  |                   |
|        | Vertical Back Porch    | tVBP   | 25    | 26    | 27   |      |                   |
|        | Vertical Front Porch   | tVFP   | 2     | 3     | 4    |      |                   |
|        | Vertical Blank         | -      | 33    | 35    | 37   |      | tWV + tVBP + tVFP |

Note: Hsync period and Hsync width-active should be even number times of tCLK. If the value is odd number times of tCLK, display control signal can be asynchronous. In order to operate this LCM a Hsync, Vsyn, and DE(data enable) signals should be used.

1. The performance of the electro-optical characteristics may be influenced by variance of the vertical refresh rates.
2. Vsync and Hsync should be keep the above specification.
3. Hsync Period, Hsync Width, and Horizontal Back Porch should be any times of of character number(8).
4. The polarity of Hsync, Vsync is not restricted.

**Product Specification**

**3-4. Signal Timing Waveforms**

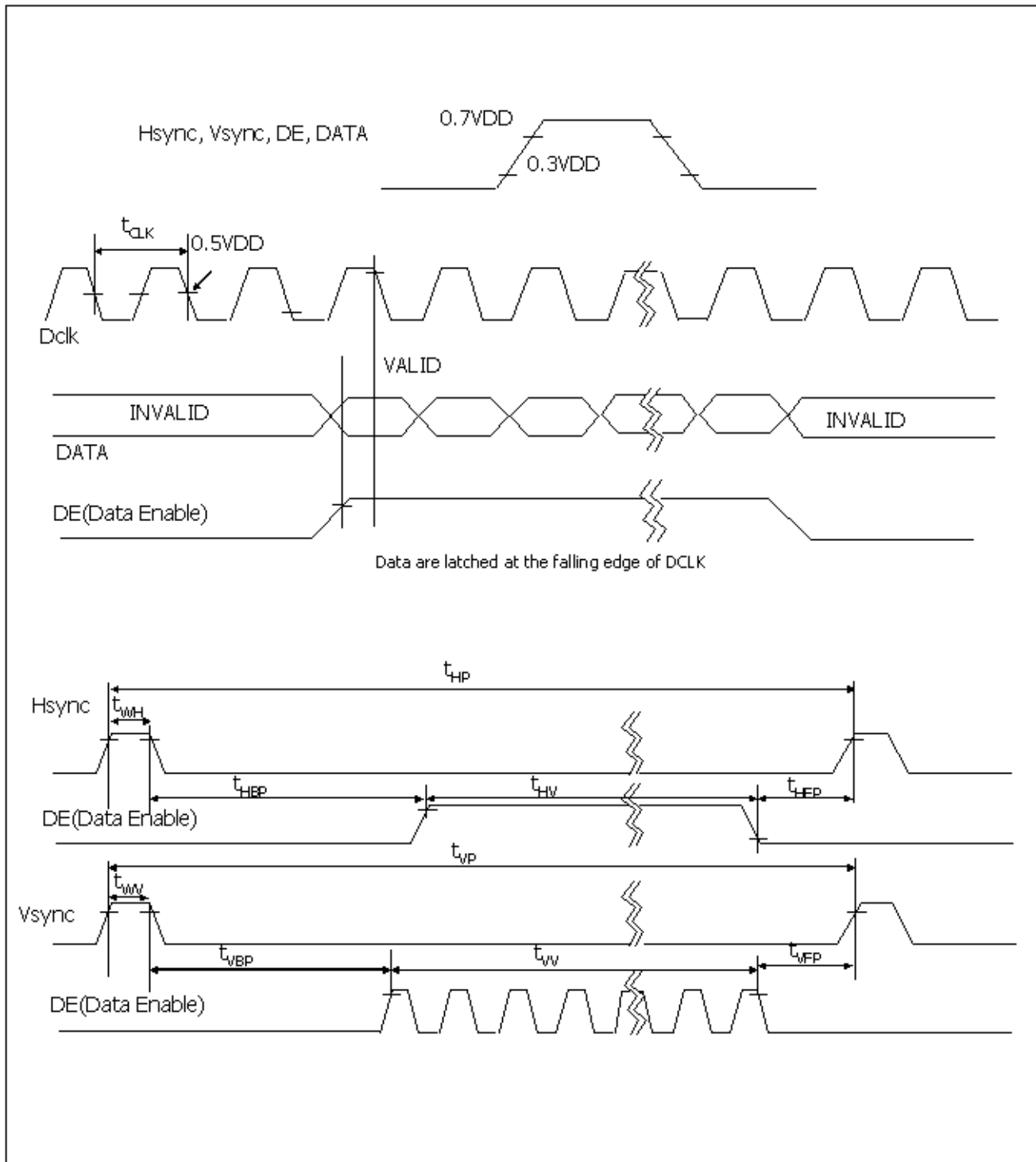

**Product Specification**

**3-5. Color Data Reference**

The Brightness of each primary color(red,green,blue) is based on the 8-bit gray scale data input for the color; the higher the binary input, the brighter the color. The table below provides a reference for color versus data input.

**Table 6. COLOR DATA REFERENCE**

| Color       |                  | Input Color Data |    |     |    |     |    |     |    |       |    |     |    |     |    |      |    |      |    |    |    |    |    |    |    |
|-------------|------------------|------------------|----|-----|----|-----|----|-----|----|-------|----|-----|----|-----|----|------|----|------|----|----|----|----|----|----|----|
|             |                  | RED              |    |     |    |     |    |     |    | GREEN |    |     |    |     |    |      |    | BLUE |    |    |    |    |    |    |    |
|             |                  | MSB              |    | RED |    | LSB |    | MSB |    | GREEN |    | LSB |    | MSB |    | BLUE |    | LSB  |    |    |    |    |    |    |    |
|             |                  | R7               | R6 | R5  | R4 | R3  | R2 | R1  | R0 | G7    | G6 | G5  | G4 | G3  | G2 | G1   | G0 | B7   | B6 | B5 | B4 | B3 | B2 | B1 | B0 |
| Basic Color | Black            | 0                | 0  | 0   | 0  | 0   | 0  | 0   | 0  | 0     | 0  | 0   | 0  | 0   | 0  | 0    | 0  | 0    | 0  | 0  | 0  | 0  | 0  | 0  | 0  |
|             | Red (255)        | 1                | 1  | 1   | 1  | 1   | 1  | 1   | 1  | 0     | 0  | 0   | 0  | 0   | 0  | 0    | 0  | 0    | 0  | 0  | 0  | 0  | 0  | 0  | 0  |
|             | Green (255)      | 0                | 0  | 0   | 0  | 0   | 0  | 0   | 0  | 1     | 1  | 1   | 1  | 1   | 1  | 1    | 1  | 0    | 0  | 0  | 0  | 0  | 0  | 0  | 0  |
|             | Blue (255)       | 0                | 0  | 0   | 0  | 0   | 0  | 0   | 0  | 0     | 0  | 0   | 0  | 0   | 0  | 0    | 0  | 1    | 1  | 1  | 1  | 1  | 1  | 1  | 1  |
|             | Cyan             | 0                | 0  | 0   | 0  | 0   | 0  | 0   | 0  | 1     | 1  | 1   | 1  | 1   | 1  | 1    | 1  | 1    | 1  | 1  | 1  | 1  | 1  | 1  | 1  |
|             | Magenta          | 1                | 1  | 1   | 1  | 1   | 1  | 1   | 1  | 0     | 0  | 0   | 0  | 0   | 0  | 0    | 0  | 1    | 1  | 1  | 1  | 1  | 1  | 1  | 1  |
|             | Yellow           | 1                | 1  | 1   | 1  | 1   | 1  | 1   | 1  | 1     | 1  | 1   | 1  | 1   | 1  | 1    | 1  | 0    | 0  | 0  | 0  | 0  | 0  | 0  | 0  |
|             | White            | 1                | 1  | 1   | 1  | 1   | 1  | 1   | 1  | 1     | 1  | 1   | 1  | 1   | 1  | 1    | 1  | 1    | 1  | 1  | 1  | 1  | 1  | 1  | 1  |
| RED         | RED (000) Dark   | 0                | 0  | 0   | 0  | 0   | 0  | 0   | 0  | 0     | 0  | 0   | 0  | 0   | 0  | 0    | 0  | 0    | 0  | 0  | 0  | 0  | 0  | 0  | 0  |
|             | RED (001)        | 0                | 0  | 0   | 0  | 0   | 0  | 0   | 1  | 0     | 0  | 0   | 0  | 0   | 0  | 0    | 0  | 0    | 0  | 0  | 0  | 0  | 0  | 0  | 0  |
|             | ...              | ...              |    |     |    |     |    |     |    | ...   |    |     |    |     |    |      |    | ...  |    |    |    |    |    |    |    |
|             | RED (254)        | 1                | 1  | 1   | 1  | 1   | 1  | 1   | 0  | 0     | 0  | 0   | 0  | 0   | 0  | 0    | 0  | 0    | 0  | 0  | 0  | 0  | 0  | 0  | 0  |
|             | RED (255)        | 1                | 1  | 1   | 1  | 1   | 1  | 1   | 1  | 0     | 0  | 0   | 0  | 0   | 0  | 0    | 0  | 0    | 0  | 0  | 0  | 0  | 0  | 0  | 0  |
| GREEN       | GREEN (000) Dark | 0                | 0  | 0   | 0  | 0   | 0  | 0   | 0  | 0     | 0  | 0   | 0  | 0   | 0  | 0    | 0  | 0    | 0  | 0  | 0  | 0  | 0  | 0  | 0  |
|             | GREEN (001)      | 0                | 0  | 0   | 0  | 0   | 0  | 0   | 0  | 0     | 0  | 0   | 0  | 0   | 0  | 0    | 1  | 0    | 0  | 0  | 0  | 0  | 0  | 0  | 0  |
|             | ...              | ...              |    |     |    |     |    |     |    | ...   |    |     |    |     |    |      |    | ...  |    |    |    |    |    |    |    |
|             | GREEN (254)      | 0                | 0  | 0   | 0  | 0   | 0  | 0   | 0  | 1     | 1  | 1   | 1  | 1   | 1  | 1    | 0  | 0    | 0  | 0  | 0  | 0  | 0  | 0  | 0  |
|             | GREEN (255)      | 0                | 0  | 0   | 0  | 0   | 0  | 0   | 0  | 1     | 1  | 1   | 1  | 1   | 1  | 1    | 1  | 0    | 0  | 0  | 0  | 0  | 0  | 0  | 0  |
| BLUE        | BLUE (000) Dark  | 0                | 0  | 0   | 0  | 0   | 0  | 0   | 0  | 0     | 0  | 0   | 0  | 0   | 0  | 0    | 0  | 0    | 0  | 0  | 0  | 0  | 0  | 0  | 0  |
|             | BLUE (001)       | 0                | 0  | 0   | 0  | 0   | 0  | 0   | 0  | 0     | 0  | 0   | 0  | 0   | 0  | 0    | 0  | 0    | 0  | 0  | 0  | 0  | 0  | 0  | 1  |
|             | ...              | ...              |    |     |    |     |    |     |    | ...   |    |     |    |     |    |      |    | ...  |    |    |    |    |    |    |    |
|             | BLUE (254)       | 0                | 0  | 0   | 0  | 0   | 0  | 0   | 0  | 0     | 0  | 0   | 0  | 0   | 0  | 0    | 0  | 1    | 1  | 1  | 1  | 1  | 1  | 1  | 0  |
|             | BLUE (255)       | 0                | 0  | 0   | 0  | 0   | 0  | 0   | 0  | 0     | 0  | 0   | 0  | 0   | 0  | 0    | 0  | 1    | 1  | 1  | 1  | 1  | 1  | 1  | 1  |

Product Specification

3-6. Power Sequence

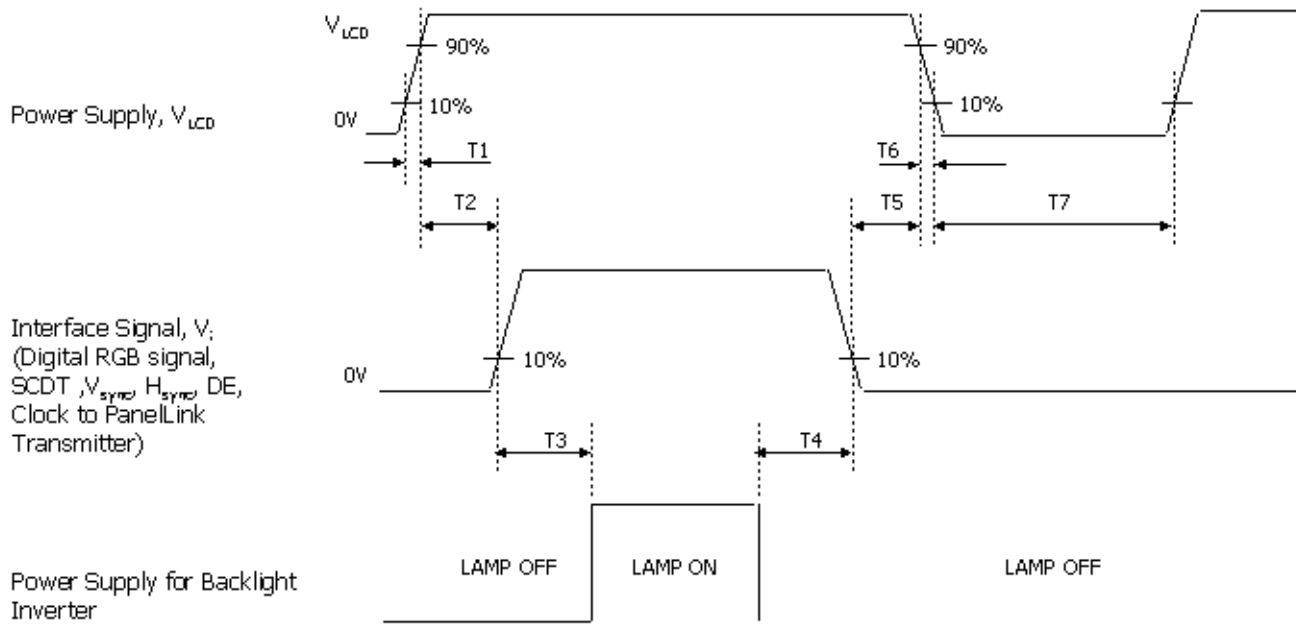

Table 7. POWER SEQUENCE

| Parameter | Values |     |     | Units |
|-----------|--------|-----|-----|-------|
|           | Min    | Typ | Max |       |
| T1        | -      | -   | 10  | ms    |
| T2        | 0.01   | -   | 50  | ms    |
| T3        | 200    | -   | -   | ms    |
| T4        | 200    | -   | -   | ms    |
| T5        | 0.01   | -   | 50  | ms    |
| T6        | 0.01   | -   | 10  | ms    |
| T7        | 1      | -   | -   | s     |

- Notes :
1. Please avoid floating state of interface signal at invalid period.
  2. When the interface signal is invalid, be sure to pull down the power supply for LCD  $V_{LCD}$  to 0V.
  3. Lamp power must be turn on after power supply for LCD and interface signal are valid.

Product Specification

3-7. Power Sequence for Inverter

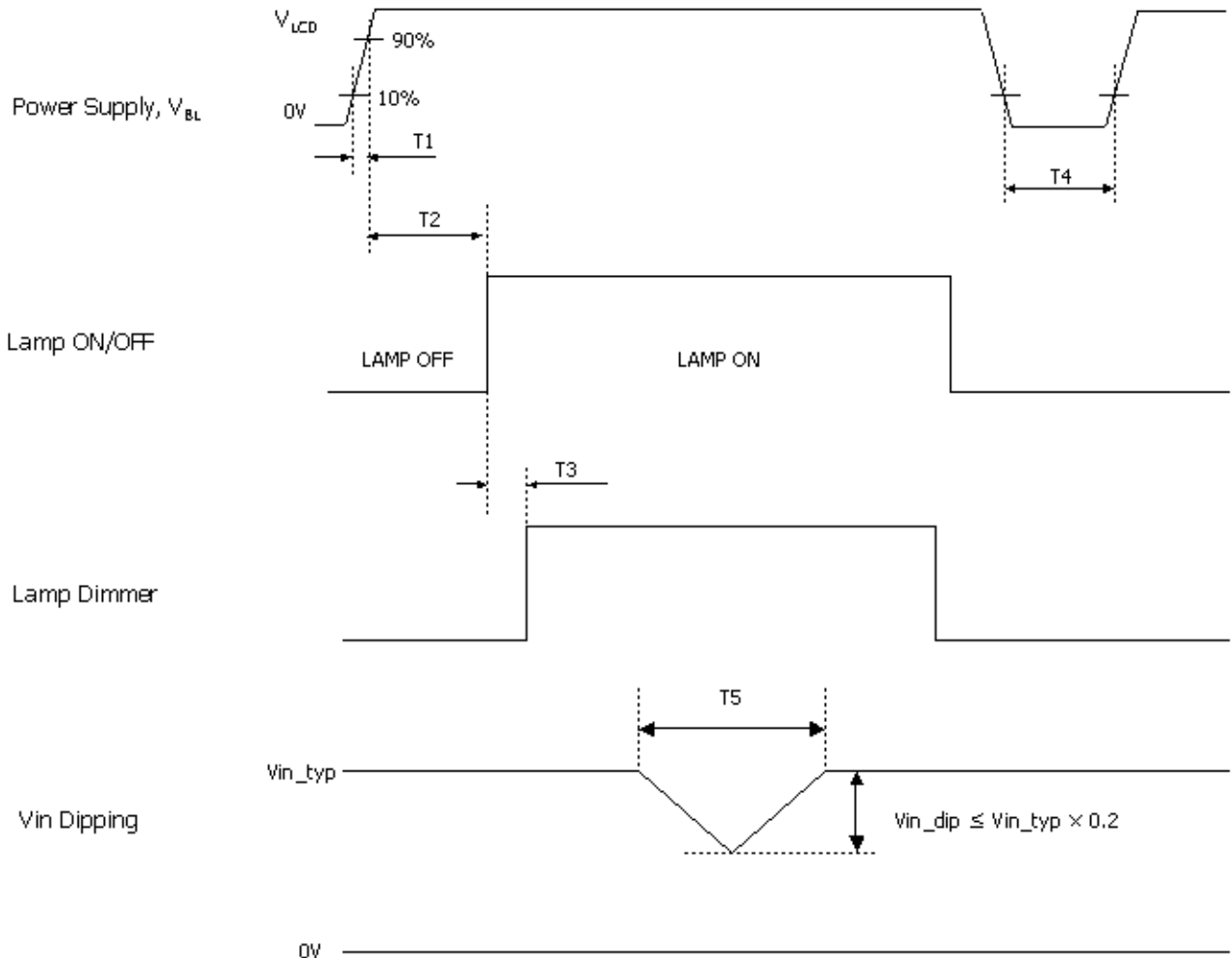

Table 8. POWER SEQUENCE

| Parameter | Values |     |     | Units |
|-----------|--------|-----|-----|-------|
|           | Min    | Typ | Max |       |
| T1        | 1      | -   | 30  | ms    |
| T2        | 200    | -   | -   | ms    |
| T3        | -      | -   | 50  | ms    |
| T4        | 500    | -   | -   | ms    |
| T5        | -      | -   | 10  | ms    |

**Product Specification**

**4. Optical Specifications**

Optical characteristics are determined after the unit has been 'ON' for approximately 30 minutes in a dark environment at  $25 \pm 2^\circ\text{C}$ . The values specified are at an approximate distance 50cm from the LCD surface at a viewing angle of  $\Phi$  and  $\theta$  equal to  $0^\circ$  and aperture 1 degree.

FIG. 1 presents additional information concerning the measurement equipment and method.

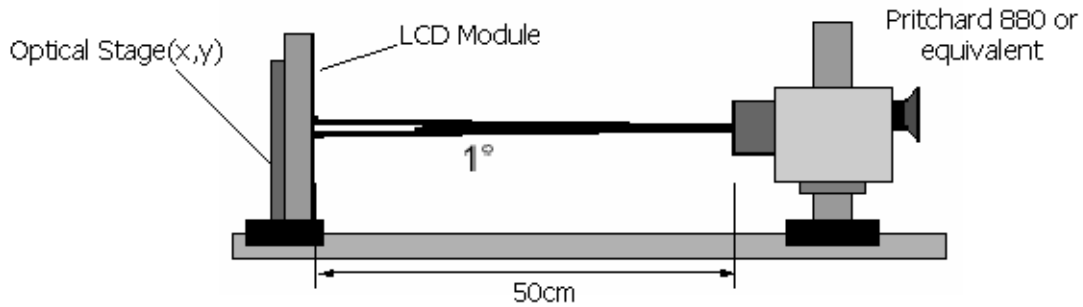

**FIG. 1 Optical Characteristic Measurement Equipment and Method**

**Table 9. OPTICAL CHARACTERISTICS**

( $T_a=25^\circ\text{C}$ ,  $V_{LCD}=12.0\text{V}$ ,  $f_v=60\text{Hz}$  Dclk=154MHz,  $V_{BR}=3.3\text{V}$ )

| Parameter                   | Symbol           | Values            |              |       | Units             | Notes  |   |
|-----------------------------|------------------|-------------------|--------------|-------|-------------------|--------|---|
|                             |                  | Min               | Typ          | Max   |                   |        |   |
| Contrast Ratio              | CR               | 500               | 800          |       |                   | 1      |   |
| Surface Luminance, white    | $L_{WH}$         | 400               | 500          |       | cd/m <sup>2</sup> | 2      |   |
| Luminance Variation         | $\delta_{WHITE}$ | 75                |              |       | %                 | 3      |   |
| Response Time               | Rise Time        | $Tr_R$            | -            | 5.5   | 12                | ms     | 4 |
|                             | Decay Time       | $Tr_D$            | -            | 6.5   | 12                | ms     | 4 |
|                             | Gray to Gray     | $T_{GTG\_AVR}$    | -            | 5     | -                 | ms     | 5 |
|                             |                  | $T_{GTG\_MAX}$    | -            | -     | 12                | ms     | 5 |
| Color Coordinates [CIE1931] | RED              | $R_x$             | Typ<br>-0.03 | 0.658 | Typ<br>+0.03      |        |   |
|                             |                  | $R_y$             |              | 0.324 |                   |        |   |
|                             | GREEN            | $G_x$             |              | 0.210 |                   |        |   |
|                             |                  | $G_y$             |              | 0.658 |                   |        |   |
|                             | BLUE             | $B_x$             |              | 0.146 |                   |        |   |
|                             |                  | $B_y$             |              | 0.065 |                   |        |   |
|                             | WHITE            | $W_x$             |              | 0.313 |                   |        |   |
|                             | $W_y$            | 0.329             |              |       |                   |        |   |
| Color Shift                 | Horizontal       | $\theta_{CST\_H}$ | -            | 178   | -                 | Degree | 6 |
|                             | Vertical         | $\theta_{CST\_V}$ | -            | 178   | -                 |        |   |
| Viewing Angle (CR>10)       |                  |                   |              |       |                   |        |   |
| General                     | Horizontal       | $\theta_H$        | 170          | 178   | -                 | Degree | 7 |
|                             | Vertical         | $\theta_V$        | 170          | 178   | -                 |        |   |
| Effective                   | Horizontal       | $\theta_{GMA\_H}$ |              | 178   | -                 | Degree | 8 |
|                             | Vertical         | $\theta_{GMA\_V}$ |              | 178   | -                 |        |   |
| Gray Scale                  |                  |                   |              | 2.2   |                   |        | 9 |



Product Specification

Notes 1. Contrast Ratio(CR) is defined mathematically as :

$$\text{Contrast Ratio} = \frac{\text{Surface Luminance with all white pixels}}{\text{Surface Luminance with all black pixels}}$$

It is measured at center point(Location P1)

2. Surface luminance(L<sub>wH</sub>)is luminance value at center point(P1) across the LCD surface 50cm from the surface with all pixels displaying white. For more information see FIG 2.

3. The variation in surface luminance , δ WHITE is defined as :

$$\delta_{\text{WHITE}} = \frac{\text{Minimum}(L_{\text{on1}}, L_{\text{on2}}, \dots, L_{\text{on9}})}{\text{Maximum}(L_{\text{on1}}, L_{\text{on2}}, \dots, L_{\text{on9}})} \times 100(\%)$$

Where L1 to L9 are the luminance with all pixels displaying white at 9 locations.  
For more information see FIG 2.

4. Response time is the time required for the display to transition from black to white (Rise Time, Tr<sub>R</sub>) and from white to black (Decay Time, Tr<sub>D</sub>). For additional information see FIG 3.

5. Gray to gray response time is the time required for the display to transition from gray to gray. For additional information see Table 10.

6. Color shift is the angle at which the color difference is lower than 0.04.  
For more information see FIG 4.

- Color difference (Δu'v')

$$u' = \frac{4x}{-2x + 12y + 3} \quad v' = \frac{9y}{-2x + 12y + 3}$$

$$\Delta u'v' = \sqrt{(u'_1 - u'_2)^2 + (v'_1 - v'_2)^2} \quad \begin{array}{l} u'_1, v'_1 : u'v' \text{ value at viewing angle direction} \\ u'_2, v'_2 : u'v' \text{ value at front } (\Theta=0) \end{array}$$

- Pattern size : 25% Box size

- Viewing angle direction of color shift : Horizontal, Vertical

7. Viewing angle is the angle at which the contrast ratio is greater than 10. The angles are determined for the horizontal or x axis and the vertical or y axis with respect to the z axis which is normal to the LCD surface. For more information see FIG 5.

8. Effective viewing angle is the angle at which the gamma shift of gray scale is lower than 0.3.  
For more information see FIG 6 and FIG 7.

9. Gray scale specification

Gamma Value is approximately 2.2. For more information see Table 11.

**Product Specification**

Measuring point for surface luminance & measuring point for luminance variation.

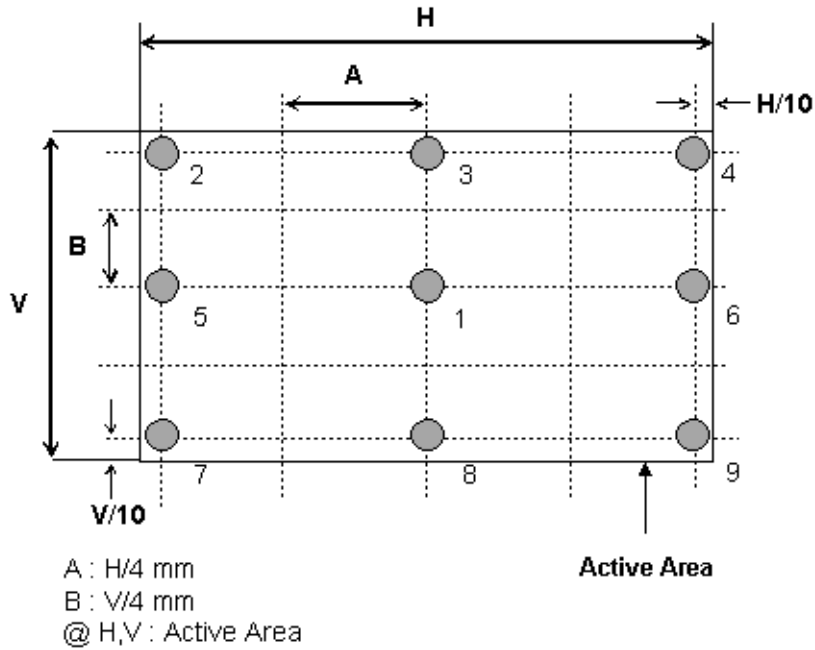

**FIG. 2 Measure Point for Luminance**

The response time is defined as the following figure and shall be measured by switching the input signal for "black" and "white".

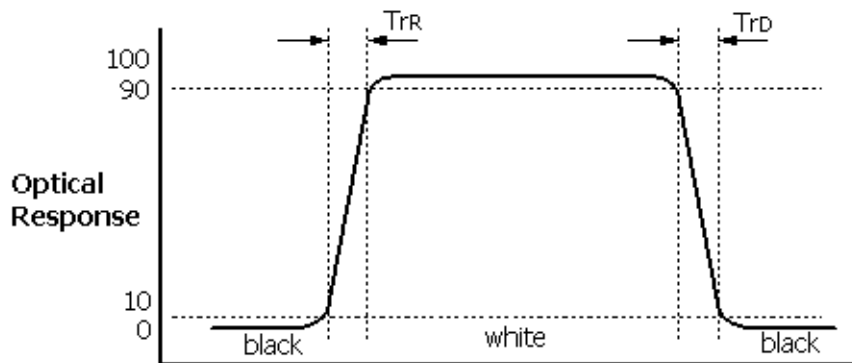

**FIG. 3 Response Time**

**Product Specification**

The gray to gray response time is defined as the following figure and shall be measured by switching the input signal for "Gray To Gray".

- Gray step : 5 step
- $T_{GTG\_AVR}$  is the total average time at rising time and falling time for "Gray To Gray".
- $T_{GTG\_MAX}$  is the max time at rising time or falling time for "Gray To Gray".

**Table 10. Gray to gray response time table**

| Gray to Gray |      | Rising Time |      |      |     |    |
|--------------|------|-------------|------|------|-----|----|
|              |      | G255        | G191 | G127 | G63 | G0 |
| Falling Time | G255 |             |      |      |     |    |
|              | G191 |             |      |      |     |    |
|              | G127 |             |      |      |     |    |
|              | G63  |             |      |      |     |    |
|              | G0   |             |      |      |     |    |

Color shift is defined as the following test pattern and color.

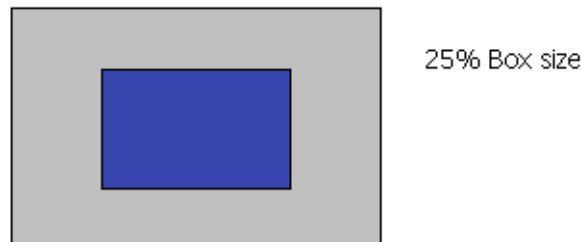

**FIG. 4 Test Pattern**

Average RGB values in Bruce RGB for Macbeth Chart

|   |           |               |              |           |              |               |
|---|-----------|---------------|--------------|-----------|--------------|---------------|
|   | Dark skin | Light skin    | Blue sky     | Foliage   | Blue flower  | Bluish green  |
| R | 98        | 206           | 85           | 77        | 129          | 114           |
| G | 56        | 142           | 112          | 102       | 118          | 199           |
| B | 45        | 123           | 161          | 46        | 185          | 178           |
|   | Orange    | Purplish blue | Moderate red | Purple    | Yellow green | Orange yellow |
| R | 219       | 56            | 211          | 76        | 160          | 230           |
| G | 104       | 69            | 67           | 39        | 193          | 162           |
| B | 24        | 174           | 87           | 86        | 58           | 29            |
|   | Blue      | Green         | Red          | Yellow    | Magenta      | cyan          |
| R | 26        | 72            | 197          | 241       | 207          | 35            |
| G | 32        | 148           | 27           | 212       | 62           | 126           |
| B | 145       | 65            | 37           | 36        | 151          | 172           |
|   | White     | Neutral 8     | Neutral 6.5  | Neutral 5 | Neutral 3.5  | black         |
| R | 240       | 206           | 155          | 110       | 63           | 22            |
| G | 240       | 206           | 155          | 110       | 63           | 22            |
| B | 240       | 206           | 155          | 110       | 63           | 22            |

Product Specification

Dimension of viewing angle range.

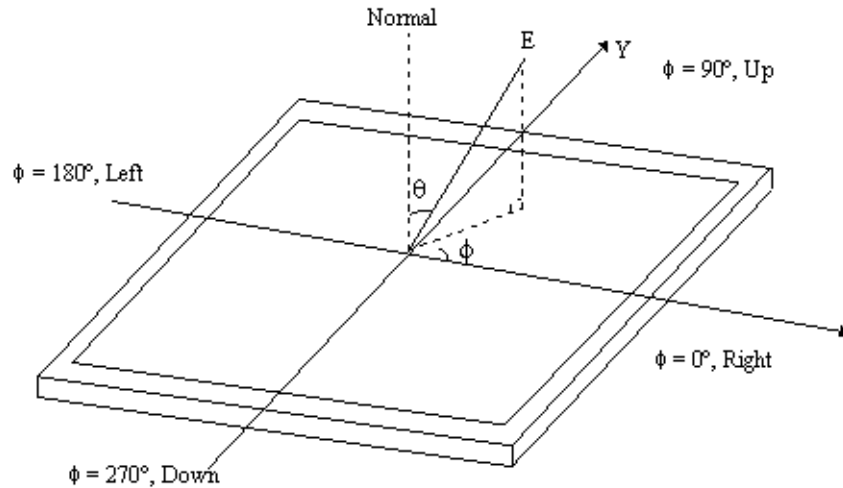

FIG. 5 Viewing angle

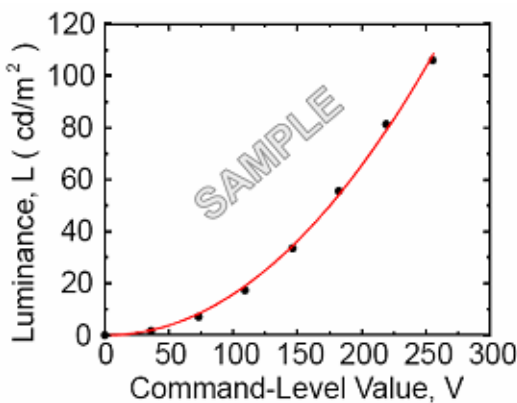

FIG. 6 Sample Luminance vs. gray scale (using a 256 bit gray scale)

$$L = aV^\gamma + L_b$$

Here the Parameter  $a$  and  $\gamma$  relate the signal level  $V$  to the luminance  $L$ .  
The GAMMA we calculate from the log-log representation (FIG. 7)

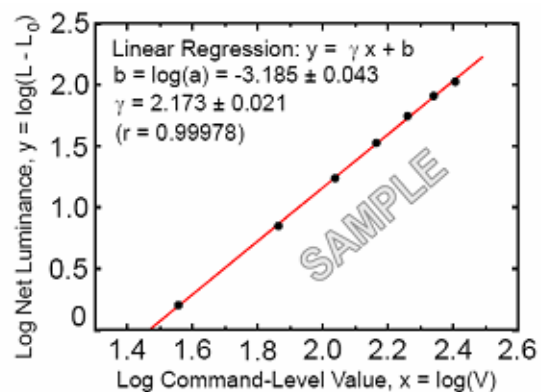

FIG. 7 Sample Log-log plot of luminance vs. gray scale

$$\log(L - L_b) = r \log(V) + \log(a)$$

Product Specification

Table 11. Gray Scale Specification

| Gray Level | Relative Luminance [%] (Typ.) |
|------------|-------------------------------|
| 0          | 0.125                         |
| 31         | 1.2                           |
| 63         | 4.7                           |
| 95         | 11.7                          |
| 127        | 21.2                          |
| 159        | 35.2                          |
| 191        | 53.0                          |
| 223        | 75.4                          |
| 255        | 100                           |

**Product Specification**

**5. Mechanical Characteristics**

The contents provide general mechanical characteristics. In addition the figures in the next page are detailed mechanical drawing of the LCD.

|                     |   |                 |
|---------------------|---|-----------------|
| Outline Dimension   | Horizontal  | <b>582.0mm</b>  |
|                     | Vertical  | <b>375.6mm</b>  |
|                     | Depth   | <b>41.5mm</b>   |
| Bezel Area          | Horizontal  | <b>554.1mm</b>  |
|                     | Vertical  | <b>347.8mm</b>  |
| Active Display Area | Horizontal  | <b>550.08mm</b> |
|                     | Vertical  | <b>343.8mm</b>  |
| Weight              | Typ : 3,520g , Max : 3,700g                                     |                 |
| Surface Treatment   | Hard coating(3H)<br>Anti-glare treatment of the front polarizer |                 |

Notes : Please refer to a mechanic drawing in terms of tolerance at the next page.



Product Specification

<REAR VIEW>

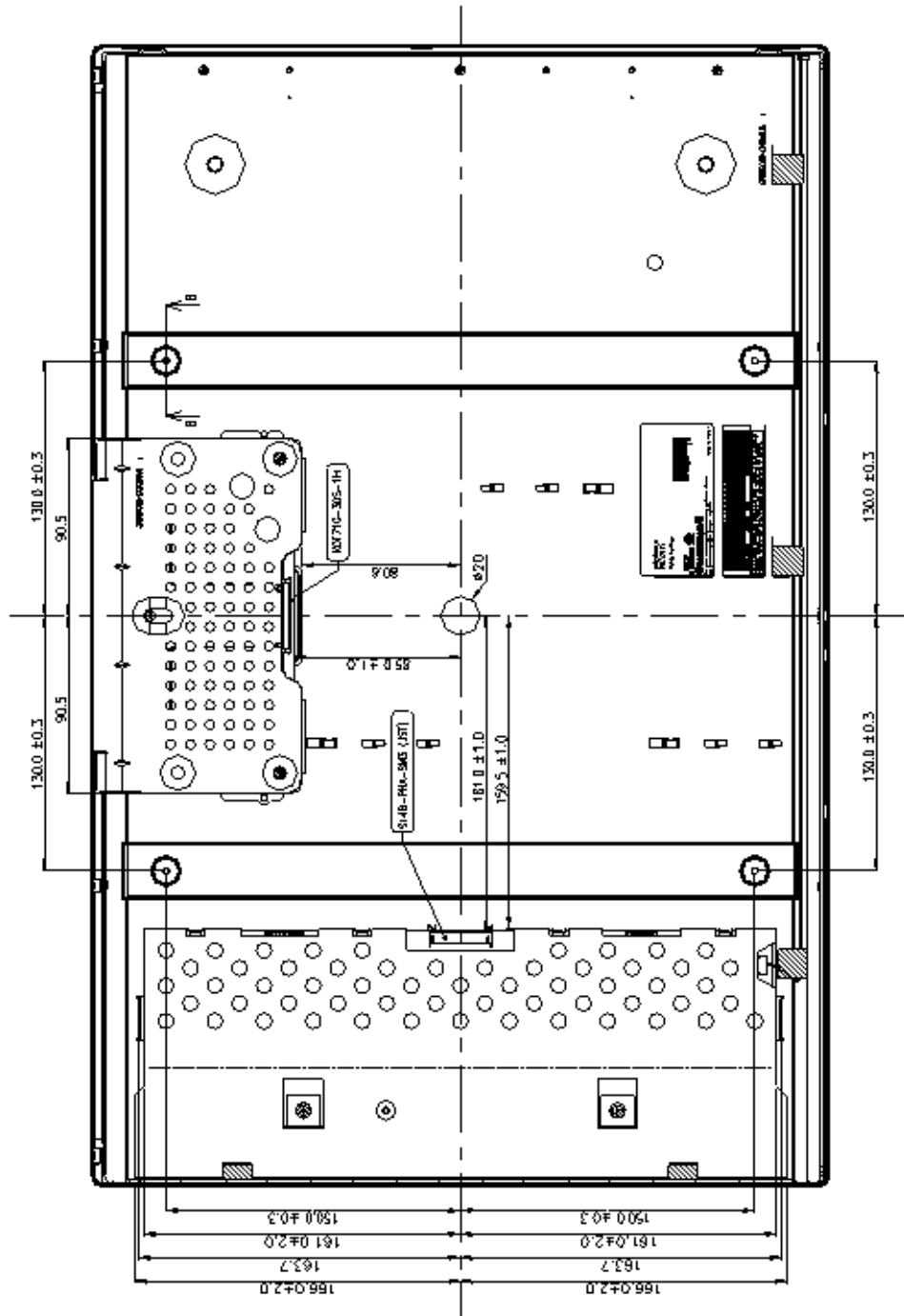

- Notes
1. Unspecified tolerances are to be  $\pm 0.5$ mm.
  2. Gap between top case and glass is  $0.5 \pm 0.2$ .
  3. Bottom surface dimensions and connection labels are excluded.
  4. Bit and axial disposition tolerance of display area are as follows:
    - (1) X-direction:  $0.4 - 0.1 \leq 1.4$ mm
    - (2) Y-direction:  $0.4 - 0.1 \leq 1.4$ mm

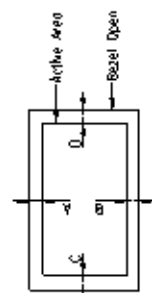

5. Torque Spec of User Mounting :  $2.0 \sim 8.0$ kgf·cm

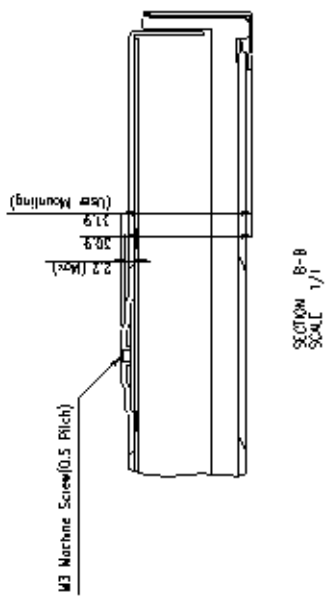



Product Specification

**6. Reliability**

Environment test condition

| No | Test Item  | Condition   |
|----|--|---|
| 1  | High temperature storage test                                | Ta= 60°C 240h   |
| 2  | Low temperature storage test                                 | Ta= -20°C 240h  |
| 3  | High temperature operation test                              | Ta= 50°C 60%RH 240h   |
| 4  | Low temperature operation test                               | Ta= 0°C 240h  |
| 5  | Vibration test<br>(non-operating)                            | Wave form : random<br>Vibration level : 1.0G RMS<br>Bandwidth : 10-500Hz<br>Duration : X,Y,Z, 10 min<br>One time each direction |
| 6  | Shock test<br>(non-operating)                                | Shock level : 100Grms<br>Waveform : half sine wave, 2ms<br>Direction : ±X, ±Y, ±Z<br>One time each direction                    |
| 7  | Humidity condition Operation                                 | Ta= 40 °C ,90%RH  |
| 8  | Altitude<br>storage / shipment                               | 0 - 40,000 feet(12192m)   |
| 9  | Maximum Storage Humidity for<br>4 corner light leakage Mura. | Max 70%RH , Ta=40°C   |

## Product Specification

### 7. International Standards

#### 7-1. Safety

- a) UL 60950-1:2003, First Edition, Underwriters Laboratories, Inc., Standard for Safety of Information Technology Equipment.
- b) CAN/CSA C22.2, No. 60950-1-03 1<sup>st</sup> Ed. April 1, 2003, Canadian Standards Association, Standard for Safety of Information Technology Equipment.
- c) EN 60950-1:2001, First Edition, European Committee for Electro technical Standardization(CENELEC) European Standard for Safety of Information Technology Equipment.
- d) RoHS, Directive 2002/95/EC of the European Parliament and of the council of 27 January 2003

#### 7-2. EMC

- a) ANSI C63.4 "Methods of Measurement of Radio-Noise Emissions from Low-Voltage Electrical and Electrical Equipment in the Range of 9kHz to 40GHz." American National Standards Institute(ANSI), 1992
- b) C.I.S.P.R. "Limits and Methods of Measurement of Radio Interface Characteristics of Information Technology Equipment." International Special Committee on Radio Interference.
- c) EN 55022 "Limits and Methods of Measurement of Radio Interface Characteristics of Information Technology Equipment." European Committee for Electro technical Standardization.(CENELEC), 1998 (Including A1: 2000 )

**Product Specification**

**8. Packing**

**8-1. Designation of Lot Mark**

a) Lot Mark

|   |   |   |   |   |   |   |   |   |   |   |   |   |
|---|---|---|---|---|---|---|---|---|---|---|---|---|
| A | B | C | D | E | F | G | H | I | J | K | L | M |
|---|---|---|---|---|---|---|---|---|---|---|---|---|

A,B,C : SIZE(INCH)  
E : MONTH

D : YEAR  
F ~ M : SERIAL NO.

Note

1. YEAR

|      |      |      |      |      |      |      |      |      |      |      |
|------|------|------|------|------|------|------|------|------|------|------|
| Year | 2001 | 2002 | 2003 | 2004 | 2005 | 2006 | 2007 | 2008 | 2009 | 2010 |
| Mark | 1    | 2    | 3    | 4    | 5    | 6    | 7    | 8    | 9    | 0    |

2. MONTH

|       |     |     |     |     |     |     |     |     |     |     |     |     |
|-------|-----|-----|-----|-----|-----|-----|-----|-----|-----|-----|-----|-----|
| Month | Jan | Feb | Mar | Apr | May | Jun | Jul | Aug | Sep | Oct | Nov | Dec |
| Mark  | 1   | 2   | 3   | 4   | 5   | 6   | 7   | 8   | 9   | A   | B   | C   |

b) Location of Lot Mark

Serial No. is printed on the label. The label is attached to the backside of the LCD module.  
This is subject to change without prior notice.

**8-2. Packing Form**

a) Package quantity in one box : 5EA

b) Box Size : 452X376X660

## Product Specification

### 9. PRECAUTIONS

Please pay attention to the followings when you use this TFT LCD module.

#### 9-1. MOUNTING PRECAUTIONS

- (1) You must mount a module using holes arranged in four corners or four sides.
- (2) You should consider the mounting structure so that uneven force (ex. Twisted stress) is not applied to the module. And the case on which a module is mounted should have sufficient strength so that external force is not transmitted directly to the module.
- (3) Please attach the surface transparent protective plate to the surface in order to protect the polarizer. Transparent protective plate should have sufficient strength in order to resist external force.
- (4) You should adopt radiation structure to satisfy the temperature specification.
- (5) Acetic acid type and chlorine type materials for the cover case are not desirable because the former generates corrosive gas of attacking the polarizer at high temperature and the latter causes circuit break by electro-chemical reaction.
- (6) Do not touch, push or rub the exposed polarizers with glass, tweezers or anything harder than HB pencil lead. And please do not rub with dust clothes with chemical treatment. Do not touch the surface of polarizer for bare hand or greasy cloth. (Some cosmetics are detrimental to the polarizer.)
- (7) When the surface becomes dusty, please wipe gently with absorbent cotton or other soft materials like chamois soaks with petroleum benzene. Normal-hexane is recommended for cleaning the adhesives used to attach front / rear polarizers. Do not use acetone, toluene and alcohol because they cause chemical damage to the polarizer.
- (8) Wipe off saliva or water drops as soon as possible. Their long time contact with polarizer causes deformations and color fading.
- (9) Do not open the case because inside circuits do not have sufficient strength.

#### 9-2. OPERATING PRECAUTIONS

- (1) The spike noise causes the mis-operation of circuits. It should be lower than following voltage :  
 $V = \pm 200\text{mV}$  (Over and under shoot voltage)
- (2) Response time depends on the temperature. (In lower temperature, it becomes longer.)
- (3) Brightness depends on the temperature. (In lower temperature, it becomes lower.)  
And in lower temperature, response time (required time that brightness is stable after turned on) becomes longer.
- (4) Be careful for condensation at sudden temperature change. Condensation makes damage to polarizer or electrical contacted parts. And after fading condensation, smear or spot will occur.
- (5) When fixed patterns are displayed for a long time, remnant image is likely to occur.
- (6) Module has high frequency circuits. Sufficient suppression to the electromagnetic interference shall be done by system manufacturers. Grounding and shielding methods may be important to minimize the interference.
- (7) Please do not give any mechanical and/or acoustical impact to LCM. Otherwise, LCM can't be operated its full characteristics perfectly.
- (8) A screw which is fastened up the steels should be a machine screw.  
(if not, it causes metallic foreign material and deal LCM a fatal blow)
- (9) Please do not set LCD on its edge.

## Product Specification

### 9-3. ELECTROSTATIC DISCHARGE CONTROL

Since a module is composed of electronic circuits, it is not strong to electrostatic discharge. Make certain that treatment persons are connected to ground through wrist band etc. And don't touch interface pin directly.

### 9-4. PRECAUTIONS FOR STRONG LIGHT EXPOSURE

Strong light exposure causes degradation of polarizer and color filter.

### 9-5. STORAGE

When storing modules as spares for a long time, the following precautions are necessary.

- (1) Store them in a dark place. Do not expose the module to sunlight or fluorescent light. Keep the temperature between 5°C and 35°C at normal humidity.
- (2) The polarizer surface should not come in contact with any other object.  
It is recommended that they be stored in the container in which they were shipped.

### 9-6. HANDLING PRECAUTIONS FOR PROTECTION FILM

- (1) The protection film is attached to the bezel with a small masking tape.  
When the protection film is peeled off, static electricity is generated between the film and polarizer.  
This should be peeled off slowly and carefully by people who are electrically grounded and with well ion-blown equipment or in such a condition, etc.
- (2) When the module with protection film attached is stored for a long time, sometimes there remains a very small amount of glue still on the bezel after the protection film is peeled off.
- (3) You can remove the glue easily. When the glue remains on the bezel surface or its vestige is recognized, please wipe them off with absorbent cotton waste or other soft material like chamois soaked with normal-hexane.