

Product Specification

SPECIFICATION FOR APPROVAL

- () Preliminary Specification
 Final Specification

Title	20.1" UXGA TFT LCD
-------	---------------------------

BUYER	
MODEL	

SUPPLIER	LG.Philips LCD CO., Ltd.
*MODEL	LM201U05
SUFFIX	SLA3

*When you obtain standard approval,
please use the above model name without suffix

SIGNATURE	DATE
/	_____
/	_____
/	_____

Please return 1 copy for your confirmation with your signature and comments.

APPROVED BY	DATE
Hans. Kim / G. Manager	_____
REVIEWED BY	
C.K. Lee / Manager	_____
PREPARED BY	
C.W. Lim / Engineer	_____

**Product Engineering Dept.
LG. Philips LCD Co., Ltd**

Product Specification

CONTENTS

NO.	ITEM	Page
-	COVER	1
-	CONTENTS	2
-	RECORD OF REVISIONS	3
1	GENERAL DESCRIPTION	4
2	ABSOLUTE MAXIMUM RATINGS	5
3	ELECTRICAL SPECIFICATIONS	6
3-1	ELECTRICAL CHARACTERISTICS	6
3-2	INTERFACE CONNECTIONS	8
3-3	SIGNAL TIMING SPECIFICATIONS	10
3-4	SIGNAL TIMING WAVE FORMS	11
3-5	COLOR INPUT DATA REFERENCE	12
3-6	POWER SEQUENCE	13
4	OPTICAL SPECIFICATIONS	14
5	MECHANICAL CHARACTERISTICS	19
6	RELIABILITY	22
7	INTERNATIONAL STANDARDS	23
7-1	SAFETY	23
7-2	EMC	23
8	PACKING	24
8-1	DESIGNATION OF LOT MARK	24
8-2	PACKING FORM	24
9	PRECAUTIONS	25
10	OTHERS	-
	APPENDIX 1. REQUIRED SIGNAL ASSIGNMENT FOR FLATLink Transmitter	27

Product Specification

RECORD OF REVISIONS

Revision No	Date	Page	Description
1.0	Jan. 24. 2008		Final Specifications.

Product Specification

1. General Description

The LM201U05-SLA3 is a Color Active Matrix Liquid Crystal Display with an integral Cold Cathode Fluorescent Lamp(CCFL) backlight system. The matrix employs a-Si Thin Film Transistor as the active element. It is a transmissive type display operating in the normally black mode. This TFT-LCD has a 20.1 inch diagonally measured active display area with UXGA resolution(1200 vertical by 1600 horizontal pixel array). Each pixel is divided into Red, Green and Blue sub-pixels or dots which are arranged in vertical stripes. Gray scale or the brightness of the sub-pixel color is determined with a 8-bit gray scale signal for each dot, thus, presenting a palette of more than 16,777,216 colors.

The LM201U05-SLA3 has been designed to apply the interface method that enables low power, high speed, low EMI. FPD Link must be used as a LVDS(Low Voltage Differential Signaling) chip. The LM201U05-SLA3 is intended to support applications where thin thickness, wide viewing angle, low power are critical factors and graphic displays are important. In combination with the vertical arrangement of the sub-pixels, the LM201U05-SLA3 characteristics provide an excellent flat panel display for office automation products such as monitors.

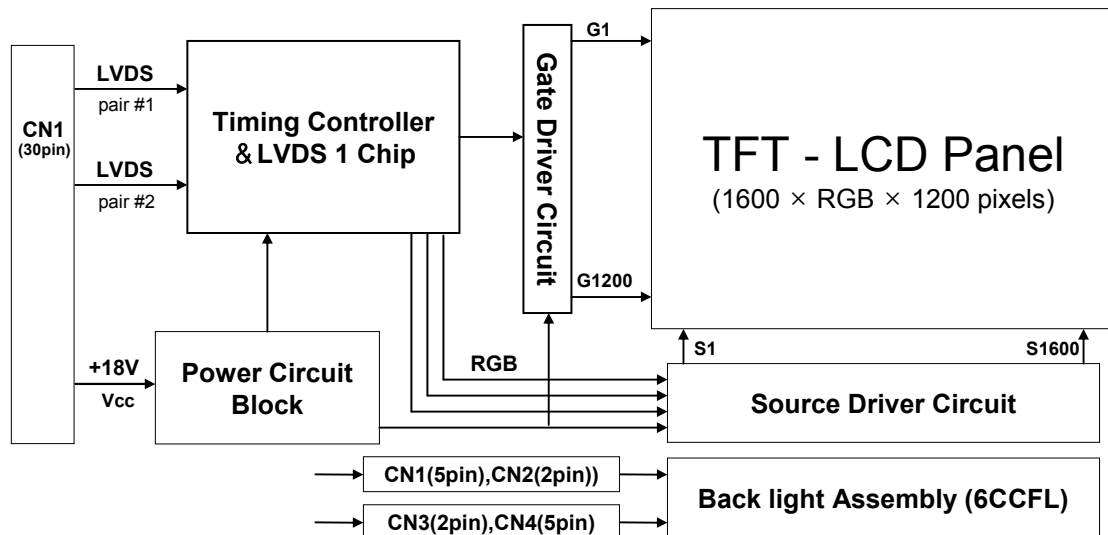

General Features

Active screen size	20.1 inches (510.54mm) diagonal
Outline Dimension	432.0(H) x 331.5(V) x 25.0(D) mm(Typ.)
Pixel Pitch	0.255 mm x 0.255 mm
Pixel Format	1600 horizontal By 1200 vertical Pixels RGB stripe arrangement
Color depth	8-bits, 16,777,216 colors
Luminance, white	300 cd/m ² (Typ. Center 1 point)
Power Consumption	Total 36.6 Watt(Typ.), (7.2 Watt @Vcc, 29.4 Watt @300cd/m ² [Lamp=7.0mA])
Weight	3200g (Typ.)
Display operating mode	Transmissive mode, normally black
Surface treatments	Hard coating (3H), Anti-glare treatment of the front polarizer

Product Specification

2. Absolute Maximum Ratings

The following are maximum values which, if exceeded, may cause faulty operation or damage to the unit.

Table 1. ABSOLUTE MAXIMUM RATINGS

Parameter	Symbol	Values		Units	Notes
		Min.	Max.		
Power Input Voltage	V_{CC}	-0.3	+23	V_{dc}	at 25°C
Operating Temperature	T_{OP}	0	+50	°C	1
Storage Temperature	T_{ST}	-20	+60	°C	1
Operating Ambient Humidity	H_{OP}	10	+90	%RH	1
Storage Humidity	H_{ST}	10	+90	%RH	1

Note : 1. Temperature and relative humidity range are shown in the figure below.
 Wet bulb temperature should be 39 °C Max, and no condensation of water.

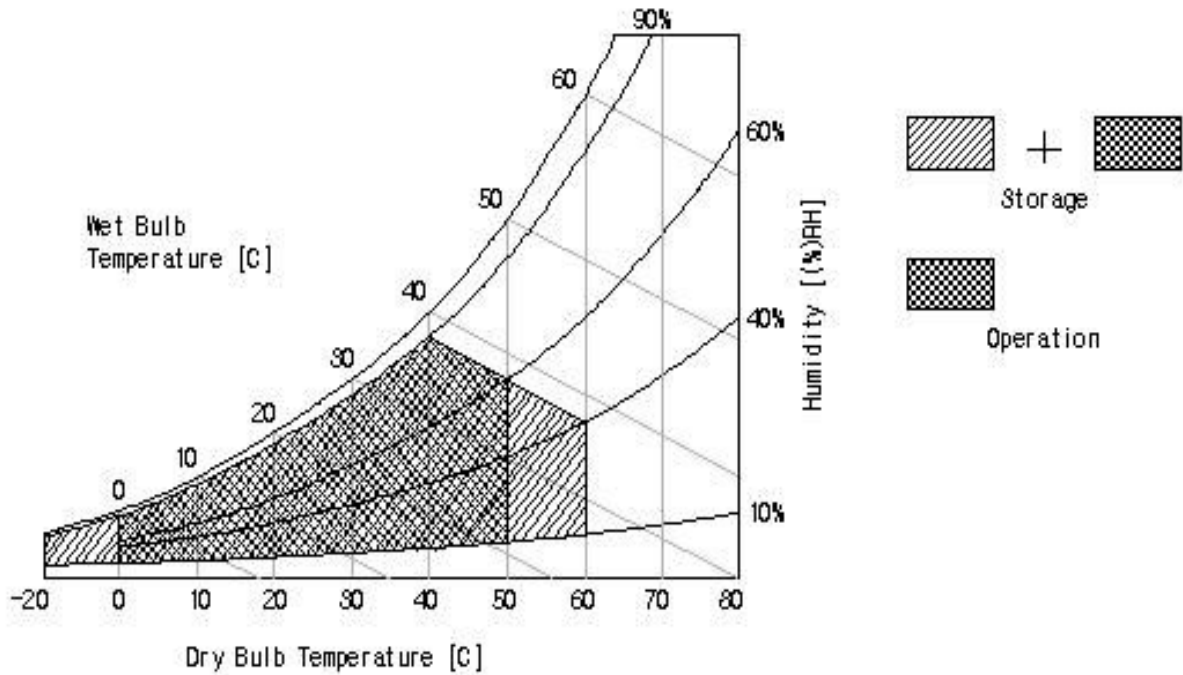

Product Specification

3. Electrical Specifications

3-1. Electrical Characteristics

The LM201U05-SLA1 requires two power inputs. One is employed to power the LCD electronics and to drive the TFT array and liquid crystal. The second input which powers the CCFL, is typically generated by an inverter. The inverter is an external unit to the LCD.

Table 2. ELECTRICAL CHARACTERISTICS

Parameter	Symbol	Values			Units	Notes
		Min.	Typ.	Max.		
MODULE:						
Power Supply Input Voltage	V_{CC}	17V	18V	19V	Vdc	1
Power Supply Input Current	I_{CC}		0.40	0.60	A	1
Power Consumption	P_c		7.2	10.8	W	1
Differential Impedance	Z_m		100		Ohm	2
Rush Current	I_{Rush}			3	A	3
LAMP (each CCFL)						
Operating voltage	V_{BL}	670(8.0mA)	700	825(3mA)	V_{RMS}	4
Operating Current	I_{BL}	3.0	7.0	8.0	mA	
Established Starting Voltage	V_s					5
at 25°C		-	-	1150	V_{RMS}	
at 0°C		-	-	1450	V_{RMS}	
Operating Frequency	F_{BL}	40	50	80	KHZ	6
Power Consumption (6 CCFL's)	P_{BL}	-	29.4	32.3	Watts	7
Discharge Stabilization Time	T_s	-	-	3	Minutes	8
Life time		45000	-	-	Hours	9

- Notes :
- The specified current and power consumption are under the $V_{CC}=18.0V$, $25^{\circ}C$, $f_v=60Hz$ condition, Typical supply current is measured at the condition of 8 X 6 chess pattern (white & black) and Max supply current is measured at the sub 1dot pattern.
 - This impedance value is for impedance matching between LVDS T_x and the mating connector of the LCD.
 - The duration of rush current is about 1ms.
 - Operating voltage is measured at $25^{\circ}C$. The variance of the voltage is $\pm 10\%$.
 - The output voltage at the transformer in the inverter must be high considering to the loss of the ballast capacitor in the inverter. The voltage above V_s should be applied to the lamps for more than 1 second for start-up. Otherwise, the lamps may not be turned on.
 - Lamp frequency may produce interface with horizontal synchronous frequency and as a result this may cause beat on the display. Therefore lamp frequency shall be as away possible from the horizontal synchronous frequency and from its harmonics in order to prevent interference.
 - The lamp power consumption shown above does not include loss of external inverter at $25^{\circ}C$. The used lamp current is the lamp typical current.
 - Let's define the brightness of the lamp after being lighted for 5 minutes as 100%. T_s is the time required for the brightness of the center of the lamp to be not less than 95%. The used lamp current is the lamp typical current.
 - The life time is defined as the time at which brightness of lamp is 50% compare to that of initial value at the typical lamp current on condition of continuous operating at $25\pm 2^{\circ}C$.

Product Specification

Note. Do not attach a conducting tape to connecting wire.
 If the lamp wire attach to a conducting tape, TFT-LCD Module has a low luminance and the inverter has abnormal action. Because leakage current is occurred between lamp wire and conducting tape.

The design of the inverter must have specifications for the lamp in LCD Assembly. The performance of the Lamp in LCM, for example life time or brightness, is extremely influenced by the characteristics of the DC-AC inverter. So all the parameters of an inverter should be carefully designed so as not to produce too much leakage current from high-voltage output of the inverter. When you design or order the inverter, please make sure unwanted lighting caused by the mismatch of the lamp and the inverter(no lighting, flicker, etc) never occurs. When you confirm it, the LCD – Assembly should be operated in the same condition as installed in you instrument.

Requirements for a system inverter design, which is intended to have a better display performance, a better power efficiency and a more reliable lamp.

It shall help increase the lamp lifetime and reduce its leakage current.

- a. The asymmetry rate of the inverter current and voltage waveform should be 10% below;
- b. The distortion rate of the current and voltage waveform should be within $\sqrt{2} \pm 10\%$;
- c. The ideal sine current and voltage waveform shall be symmetric in positive and negative polarities.

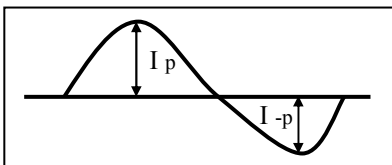

* Asymmetry rate = $| I_p - I_{-p} | / I_{rms} * 100\%$

* Distortion rate = $I_p \text{ (or } I_{-p}) / I_{rms}$

Product Specification

3-2. Interface Connections

Interface chip must be used LVDS, part No. DS90CF383MTD(Transmitter) made by National Semiconductor. Or used the compatible interface chips(TI:SN75LVDS83).
 This LCD employs seven interface connections, a 30-pin connector is used for the module electronics interface. Six 2-pin connectors are used for the integral back-light system.
 The electronics interface connector is locking type and a model IS100-L30R-C23 manufactured by UJU or FI-XB30SSRL-HF16 manufactured by JAE, The mating connector part number FI-X30M(JAE) or equivalent. The pin configuration for the connector is shown in the table 3.

Table 3. MODULE CONNECTOR PIN CONFIGURATION(LVDS)

Pin	Symbol	Description
1	Vcc	Supply voltage for LCD module
2	Vcc	Supply voltage for LCD module
3	Vcc	Supply voltage for LCD module
4	Vcc	Supply voltage for LCD module
5	NC	NC (No Connection)
6	NC	NC (No Connection)
7	SR3P	Plus signal of even channel 3 (LVDS)
8	SR3M	Minus signal of even channel 3 (LVDS)
9	SCLKINP	Plus signal of even clock channel (LVDS)
10	SCLKINM	Minus signal of even clock channel (LVDS)
11	SR2P	Plus signal of even channel 2 (LVDS)
12	SR2M	Minus signal of even channel 2 (LVDS)
13	SR1P	Plus signal of even channel 1 (LVDS)
14	SR1M	Minus signal of even channel 1 (LVDS)
15	SR0P	Plus signal of even channel 0 (LVDS)
16	SR0M	Minus signal of even channel 0 (LVDS)
17	GND	Ground
18	GND	Ground
19	FR3P	Plus signal of odd channel 3 (LVDS)
20	FR3M	Minus signal of odd channel 3 (LVDS)
21	FCLKINP	Plus signal of odd clock channel (LVDS)
22	FCLKINM	Minus signal of odd clock channel (LVDS)
23	FR2P	Plus signal of odd channel 2 (LVDS)
24	FR2M	Minus signal of odd channel 2 (LVDS)
25	FR1P	Plus signal of odd channel 1 (LVDS)
26	FR1M	Minus signal of odd channel 1 (LVDS)
27	FR0P	Plus signal of odd channel 0 (LVDS)
28	FR0M	Minus signal of odd channel 0 (LVDS)
29	GND	Ground
30	GND	Ground

Second data

First data

Connector pin arrangement

P/N, Maker :
IS100-L30R-C23 , UJU

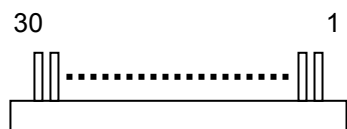

Product Specification

The backlight interface connector is a model 1674817-1(CN2/CN3) manufactured by AMP (or equivalent BHSR-02VS-1 manufactured by JST) and BHR-05VS-1 (CN1/CN4) manufactured by JST. The mating connector part number are SM02B-BHSS-1-TB(2pin), SM04(9-E2)B-BHS-1-TB or equivalent. The pin configuration for the connector is shown in the table below.

Table 4. BACKLIGHT CONNECTOR PIN CONFIGURATION

No	Pin	Symbol	Description	Notes
CN1	1	HV	Power supply for lamp 1(High voltage side)	1
	2	HV	Power supply for lamp 2(High voltage side)	1
	3	NC	NC	
	4	LV	Power supply for lamp 1(Low voltage side)	
	5	LV	Power supply for lamp 2(Low voltage side)	
CN2	1	HV	Power supply for lamp 3(High voltage side)	1
	2	LV	Power supply for lamp 3(Low voltage side)	
CN3	1	HV	Power supply for lamp 4(High voltage side)	1
	2	LV	Power supply for lamp 4(Low voltage side)	
CN4	1	HV	Power supply for lamp 6(High voltage side)	1
	2	HV	Power supply for lamp 5(High voltage side)	1
	3	NC	NC	
	4	LV	Power supply for lamp 6(Low voltage side)	
	5	LV	Power supply for lamp 5(Low voltage side)	

- Notes: 1. The high voltage power terminal is thick line.
2. The low voltage power terminal is thin line.

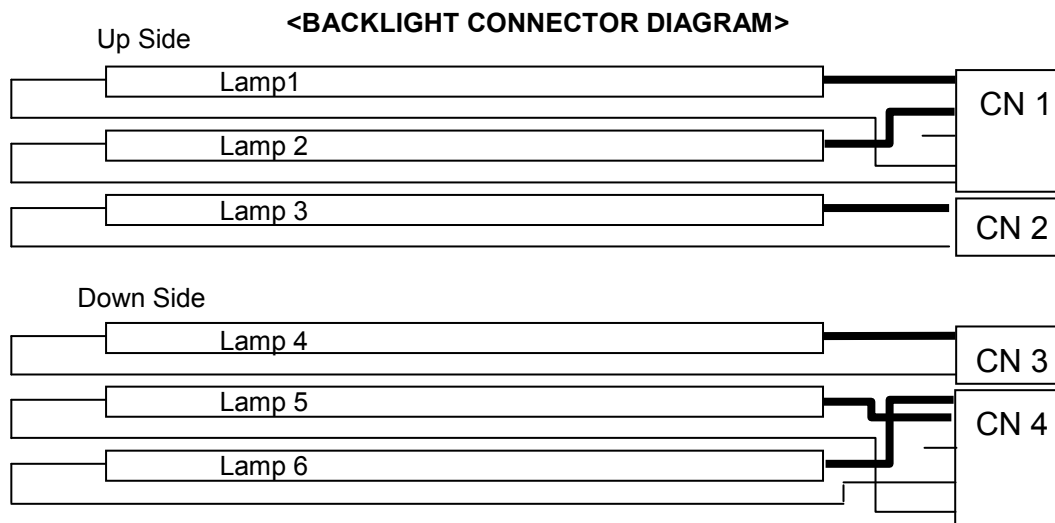

Product Specification

3-3. Signal Timing Specifications

This is the signal timing required at the input of the LVDS Transmitter. All of the interface signal timing should be satisfied with the following specifications for its proper operation.

Table 5. Timing Table

ITEM		SYMBOL	Min	Typ	Max	Unit	Note
DCLK	Period	t _{CLK}	14.28	15.625	16.00	ns	
	Frequency	f _{CLK}	62.5	64.0	70.0	MHz	2pixel/clock
Hsync	Period	t _{HP}	852	860	906	t _{CLK}	1
	Width-Active	t _{WH}	16	16	16		2
Vsync	Period	t _{VP}	1230	1240	1250	t _{HP}	
	Frequency	f _V	59	60	61	Hz	3
	Width-Active	t _{WV}	2	4	4	t _{HP}	4
Data Enable	Horizontal Valid	t _{HV}	800	800	800	t _{CLK}	
	Horizontal Back Porch	t _{HBP}	20	24	48		
	Horizontal Front Porch	t _{HFP}	16	20	42		
	Horizontal Blank		52	60	106		=t _{WH} + t _{HBP} + t _{HFP}
	Vertical Valid	t _{VV}	1200	1200	1200	t _{HP}	
	Vertical Back Porch	t _{VBP}	24	32	42		
	Vertical Front Porch	t _{VFP}	4	4	4		
	Vertical Blank	-	30	40	50		t _{WV} + t _{VBP} + t _{VFP}

- Notes: 1. Hsync period shall be a double number of 4 (based on 2pixel/clock)
 2. Horizontal sync shall be active high.
 3. Vertical frequency should be keep the above specification when the resolution & mode are changed.
 4. Vertical sync shall be active high.

Product Specification

3-4. Signal Timing Waveforms

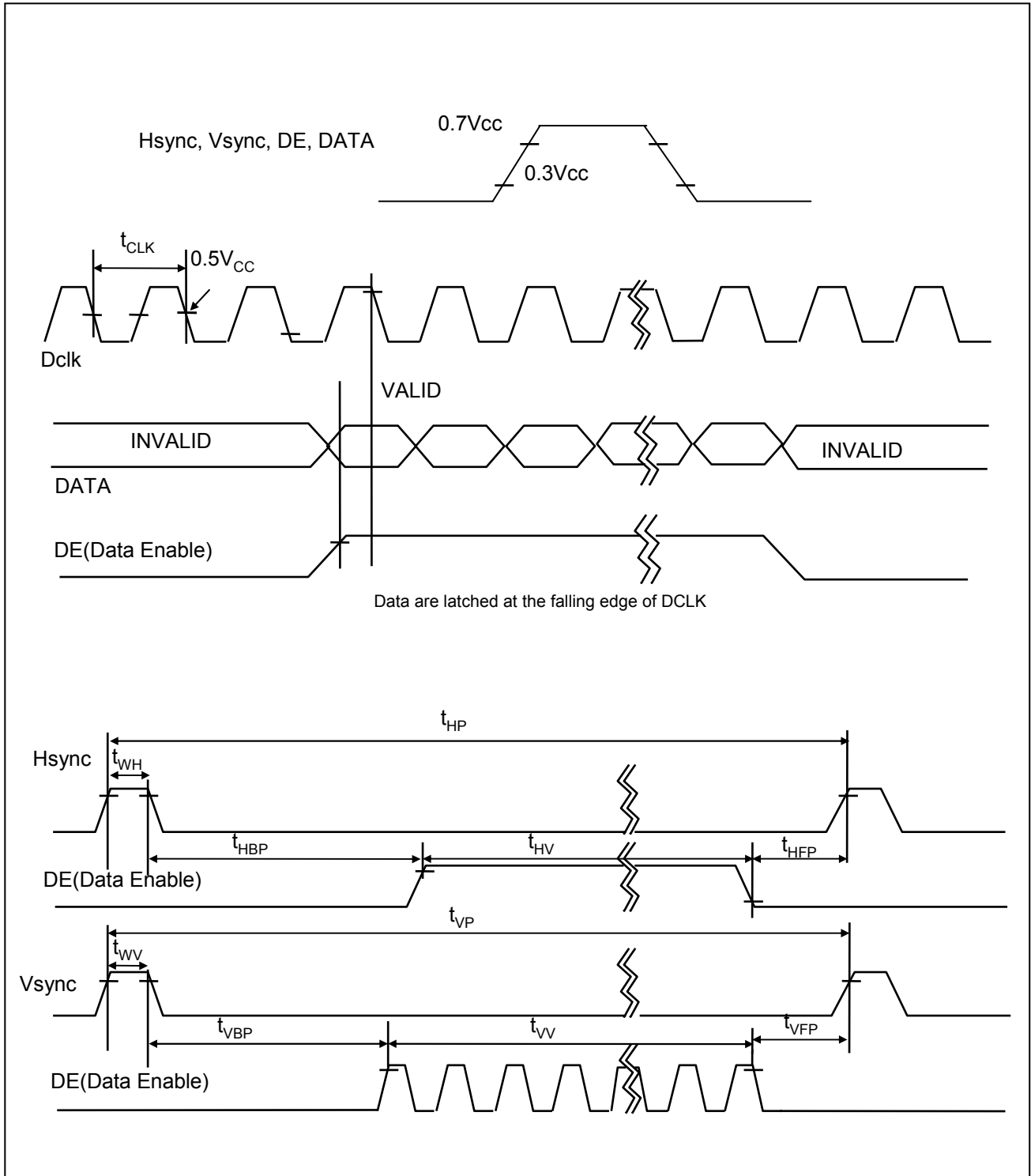

Product Specification

3-5. Color Input Data Reference

The brightness of each primary color(red,green and blue) is based on the 8-bit gray scale data input for the color ; the higher the binary input, the brighter the color. The table below provides a reference for color versus data input.

Table 6. COLOR DATA REFERENCE

Color		Input Color Data																							
		Red								Green								Blue							
		MSB				LSB				MSB				LSB				MSB				LSB			
		R7	R6	R5	R4	R3	R2	R1	R0	G7	G6	G5	G4	G3	G2	G1	G0	B7	B6	B5	B4	B3	B2	B1	B0
Basic Color	Black	0	0	0	0	0	0	0	0	0	0	0	0	0	0	0	0	0	0	0	0	0	0	0	0
	Red (255)	1	1	1	1	1	1	1	1	0	0	0	0	0	0	0	0	0	0	0	0	0	0	0	0
	Green (255)	0	0	0	0	0	0	0	0	1	1	1	1	1	1	1	1	0	0	0	0	0	0	0	0
	Blue (255)	0	0	0	0	0	0	0	0	0	0	0	0	0	0	0	0	1	1	1	1	1	1	1	1
	Cyan	0	0	0	0	0	0	0	0	1	1	1	1	1	1	1	1	1	1	1	1	1	1	1	1
	Magenta	1	1	1	1	1	1	1	1	0	0	0	0	0	0	0	0	1	1	1	1	1	1	1	1
	Yellow	1	1	1	1	1	1	1	1	1	1	1	1	1	1	1	1	0	0	0	0	0	0	0	0
	White	1	1	1	1	1	1	1	1	1	1	1	1	1	1	1	1	1	1	1	1	1	1	1	1
Red	Red(000) Dark	0	0	0	0	0	0	0	0	0	0	0	0	0	0	0	0	0	0	0	0	0	0	0	0
	Red(001)	0	0	0	0	0	0	0	1	0	0	0	0	0	0	0	0	0	0	0	0	0	0	0	0
	Red(002)	0	0	0	0	0	0	1	0	0	0	0	0	0	0	0	0	0	0	0	0	0	0	0	0
	-----	-	-	-	-	-	-	-	-	-	-	-	-	-	-	-	-	-	-	-	-	-	-	-	-
	-----	-	-	-	-	-	-	-	-	-	-	-	-	-	-	-	-	-	-	-	-	-	-	-	-
	Red(253)	1	1	1	1	1	1	0	1	0	0	0	0	0	0	0	0	0	0	0	0	0	0	0	0
	Red(254)	1	1	1	1	1	1	1	0	0	0	0	0	0	0	0	0	0	0	0	0	0	0	0	0
	Red(255) Bright	1	1	1	1	1	1	1	1	0	0	0	0	0	0	0	0	0	0	0	0	0	0	0	0
Green	Green(000) Dark	0	0	0	0	0	0	0	0	0	0	0	0	0	0	0	0	0	0	0	0	0	0	0	0
	Green(001)	0	0	0	0	0	0	0	0	0	0	0	0	0	0	1	0	0	0	0	0	0	0	0	0
	Green(002)	0	0	0	0	0	0	0	0	0	0	0	0	0	1	0	0	0	0	0	0	0	0	0	0
	-----	-	-	-	-	-	-	-	-	-	-	-	-	-	-	-	-	-	-	-	-	-	-	-	-
	-----	-	-	-	-	-	-	-	-	-	-	-	-	-	-	-	-	-	-	-	-	-	-	-	-
	Green(253)	0	0	0	0	0	0	0	0	1	1	1	1	1	1	0	1	0	0	0	0	0	0	0	0
	Green(254)	0	0	0	0	0	0	0	0	1	1	1	1	1	1	1	0	0	0	0	0	0	0	0	0
	Green(255) Bright	0	0	0	0	0	0	0	0	1	1	1	1	1	1	1	1	0	0	0	0	0	0	0	0
Blue	Blue(000) Dark	0	0	0	0	0	0	0	0	0	0	0	0	0	0	0	0	0	0	0	0	0	0	0	0
	Blue(001)	0	0	0	0	0	0	0	0	0	0	0	0	0	0	0	0	0	0	0	0	0	0	0	1
	Blue(002)	0	0	0	0	0	0	0	0	0	0	0	0	0	0	0	0	0	0	0	0	0	0	1	0
	-----	-	-	-	-	-	-	-	-	-	-	-	-	-	-	-	-	-	-	-	-	-	-	-	-
	-----	-	-	-	-	-	-	-	-	-	-	-	-	-	-	-	-	-	-	-	-	-	-	-	-
	Blue(253)	0	0	0	0	0	0	0	0	0	0	0	0	0	0	0	0	1	1	1	1	1	1	0	1
	Blue(254)	0	0	0	0	0	0	0	0	0	0	0	0	0	0	0	0	1	1	1	1	1	1	1	0
	Blue(255) Bright	0	0	0	0	0	0	0	0	0	0	0	0	0	0	0	0	1	1	1	1	1	1	1	1

Product Specification

3-6. Power Sequence

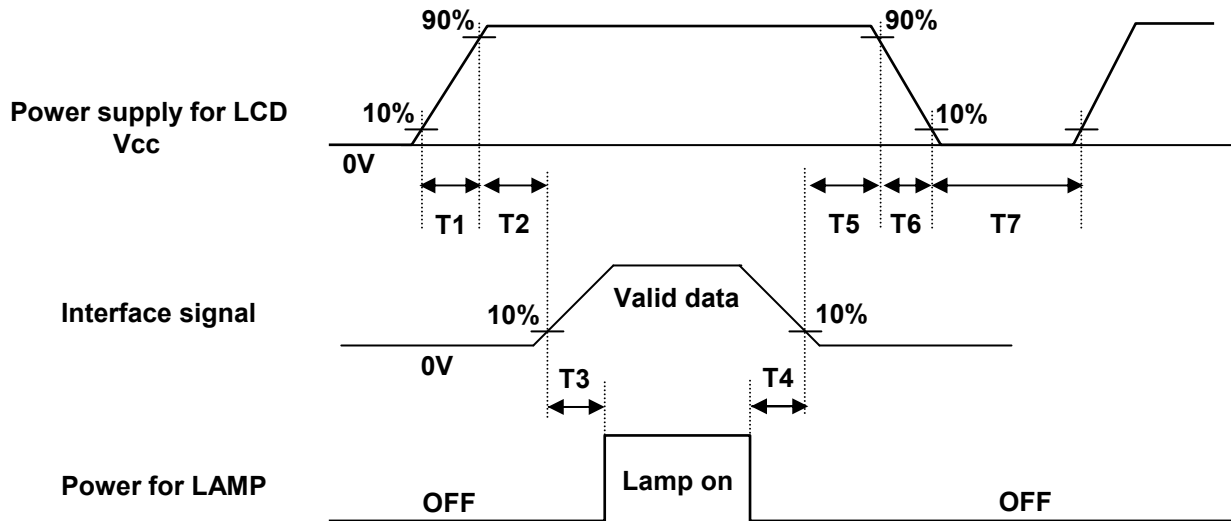

Table 7. POWER SEQUENCE

Parameter	Values			Units
	Min.	Typ.	Max.	
T 1	–	–	10	ms
T 2	0	–	50	ms
T 3	200	–	–	ms
T 4	200	–	–	ms
T 5	0	–	50	ms
T 6	-	–	10	ms
T 7	400	–	–	ms

- Notes :
1. Please avoid floating state of interface signal at invalid period.
 2. When the interface signal is invalid, be sure to pull down the power supply for LCD V_{CC} to 0V. Invalid signal with V_{CC} for a long period of time, causes permanent damage to LCD panel.
 3. Lamp power must be turn on after power supply for LCD and interface signals are valid.

Product Specification

4. Optical Specifications

Optical characteristics are determined after the unit has been 'ON' for 30 minutes in a dark environment at 25 °C. The values specified are at an approximate distance 50cm from the LCD surface at a viewing angle of Φ and θ equal to 0°.

FIG. 1 presents additional information concerning the measurement equipment and method.

FIG. 1 Optical Characteristic Measurement Equipment and Method

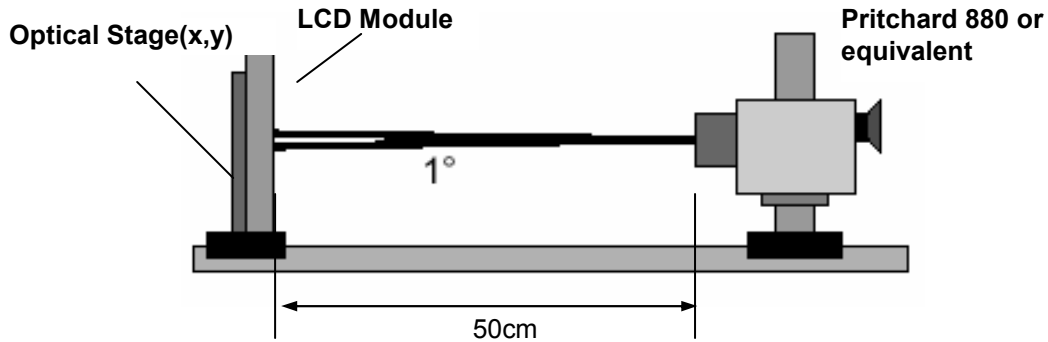

Table 8. OPTICAL CHARACTERISTICS (Ta=25 °C, V_{CC}=18.0V, f_V=60Hz, Dclk=128MHz, I_{BL}=7.0mA_{rms})

Parameter	Symbol	Values			Units	Notes	
		Min	Typ	MAx			
Contrast Ratio	CR	400	800			1	
Surface Luminance, white	L _{WH}	250	300		cd/m ²	2	
Luminance Variation	δ_{WHITE}	70	-	-	%	3	
Response Time	Rise Time	T _R	7	25	ms	4	
	Decay Time	T _D	9		ms	4	
	Gray To Gray	T _{GTG_AVR}	-	8	-	ms	5
T _{GTG_MAX}		-	14	-	ms	5	
Color Coordinates							
RED	RX		0.639	+0.03			
	RY		0.342				
GREEN	GX		0.290				
	GY		0.615				
BLUE	BX	-0.03	0.146				
	BY		0.072				
WHITE	WX		0.313				
	WY		0.329				
Color shift							
Horizontal	θ_{CST_H}	-	178	-	degree	6	
	Vertical	θ_{CST_V}	-	178	-		
Viewing Angle							
general	Horizontal	θ_H	-	178	-	degree	7
	Vertical	θ_V	-	178	-		
Effective	Horizontal	θ_{GMA_H}	-	178	-	degree	8
	Vertical	θ_{GMA_V}	-	178	-		
Gray Scale			2.2			9	

Product Specification

Notes 1. Contrast Ratio(CR) is defined mathematically as :

$$\text{Contrast Ratio} = \frac{\text{Surface Luminance with all white pixels}}{\text{Surface Luminance with all black pixels}}$$

2. Surface luminance is the center point across the LCD surface 50cm from the surface with all pixels displaying white under the condition of IBL = 7.0mArms . For more information see FIG 2.

3. The variation in surface luminance , δ WHITE is determined by measuring LON at each test position 1 through 9, and then dividing the maximum LON of 9 points luminance by minimum LON of 9 points luminance. For more information see FIG 2

$$\text{WHITE} = [\text{Minimum}(\text{LON1}, \text{LON2}, \dots, \text{LON9}) / \text{Maximum}(\text{LON1}, \text{LON2}, \dots, \text{LON9})] \times 100 [\%]$$

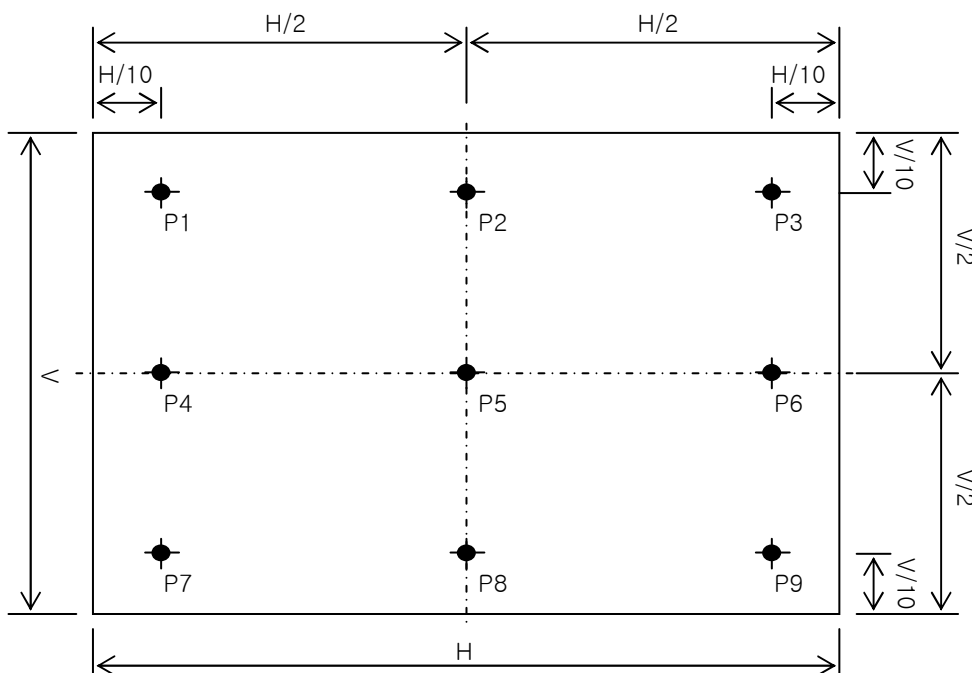

FIG. 2 Measure Point for Luminance variation

Product Specification

4. **The response time** is defined as the following figure and shall be measured by switching the input signal for “black” and “white”.
 Response time is the time required for the display to transition from black to white (Rise Time, T_{rR}) and from white to black (Decay Time, T_{rD}).

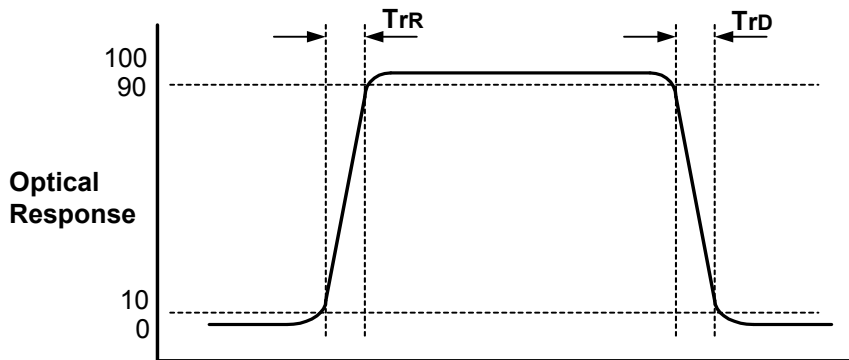

FIG. 3 Response Time

5. **The Gray to Gray response time** is defined as the following figure and shall be measured by switching the input signal for “Gray To Gray “.
- Gray step : 5 Step
 - T_{GTG_AVR} is the total average time at rising time and falling time for “Gray To Gray “.
 - T_{GTG_MAX} is the max time at rising time or falling time for “Gray To Gray “.

Gray to Gray		Rising Time				
		G255	G191	G127	G63	G0
Falling Time	G255					
	G191					
	G127					
	G63					
	G0					

Product Specification

6. **Color shift** is the angle at which the color difference is lower than 0.04.

- Color difference ($\Delta u'v'$)

$$u' = \frac{4x}{-2x + 12y + 3}$$

$$v' = \frac{9y}{-2x + 12y + 3}$$

$$\Delta u'v' = \sqrt{(u'_1 - u'_2)^2 + (v'_1 - v'_2)^2}$$

u'_1, v'_1 : $u'v'$ value at viewing angle direction

u'_2, v'_2 : $u'v'$ value at front($\theta=0$)

- Pattern size : 25% Box size

- Viewing angle direction of color shift : Horizontal, Vertical

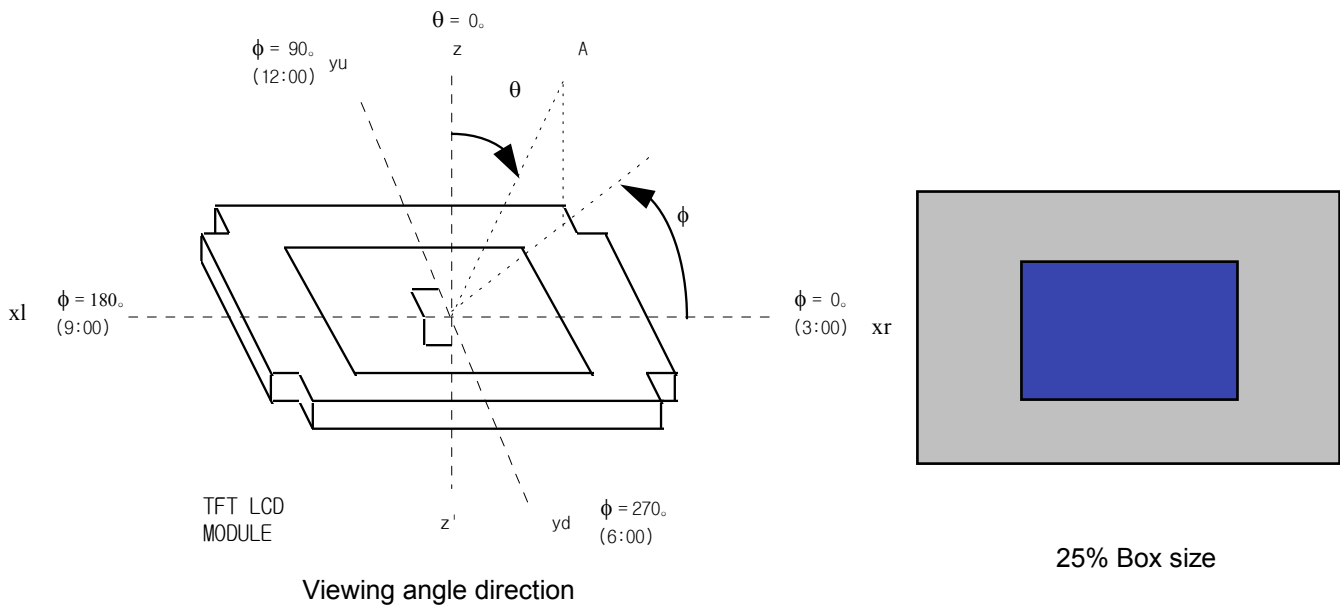

AVERAGE RGB VALUES IN BRUCE RGB FOR MACBETH CHART

	dark skin	light skin	blue sky	foliage	blue flower	bluish green
R	98	206	85	77	129	114
G	56	142	112	102	118	199
B	45	123	161	46	185	178
	orange	purplish blue	moderate red	purple	yellow green	orange yellow
R	219	56	211	76	160	230
G	104	69	67	39	193	162
B	24	174	87	86	58	29
	blue	green	red	yellow	magenta	cyan
R	26	72	197	241	207	35
G	32	148	27	212	62	126
B	145	65	37	36	151	172
	white	neutral 8	neutral 6,5	neutral 5	neutral 3,5	black
R	240	206	155	110	63	22
G	240	206	155	110	63	22
B	240	206	155	110	63	22

(Test Pattern : Macbeth Chart)

Product Specification

7. **Viewing angle(general)** is the angle at which the contrast ratio is greater than 10.

8. **Effective viewing angle** is the angle at which the gamma shift of gray scale is lower than 0.3.

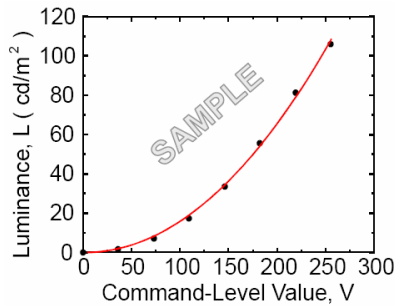

Fig. 1. Sample Luminance vs. gray scale (using a 256 bit gray scale).

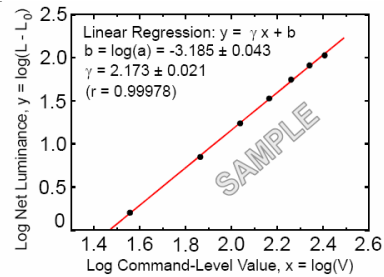

Fig. 2. Sample Log-log plot of luminance vs. gray scale.

$$L = aV^r + L_b$$

FIG. 4

$$\log(L - L_b) = r \log(V) + \log(a)$$

Here the Parameter α and γ relate the signal level V to the luminance L.

The GAMMA we calculate from the log-log representation(Fig, 4)

9. Grayscale Specification

Gray Level	Relative Luminance [%] (Typ.)
0	0.14
31	1.20
63	4.57
95	11.3
127	21.4
159	35.2
191	52.8
223	74.4
255	100

Product Specification

5. Mechanical Characteristics

The contents provide general mechanical characteristics for the model LM201U04-SL02 . In addition, the figures in the next page are detailed mechanical drawing of the LCD.

Outside dimensions	Horizontal	432.0 ± 0.5mm
	Vertical	331.5 ± 0.5mm
	Depth	25.0 ± 0.5 mm
Bezel area	Horizontal	413.0 mm
	Vertical	311.0 mm
Active display area	Horizontal	408.0 mm
	Vertical	306.0 mm
Weight (approximate)	3,200g (Typ.)	
Surface Treatment	Hard coating (3H) Anti-glare treatment of the front polarizer Haze (25%)	

Product Specification

<FRONT VIEW>

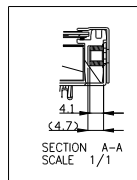
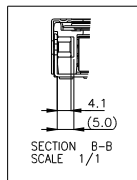
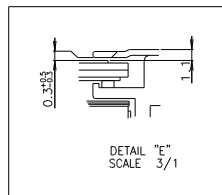
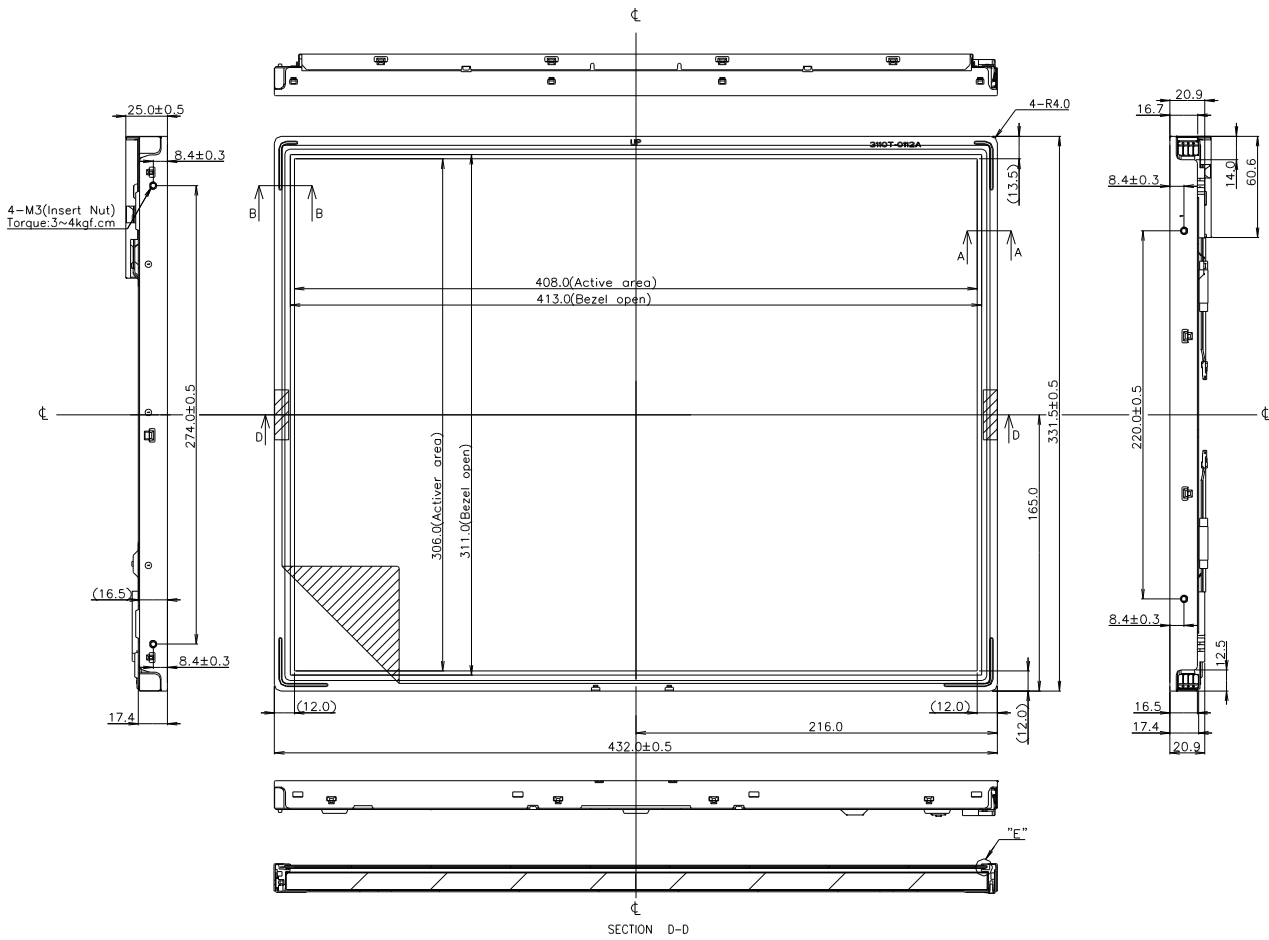

Product Specification

<REAR VIEW>

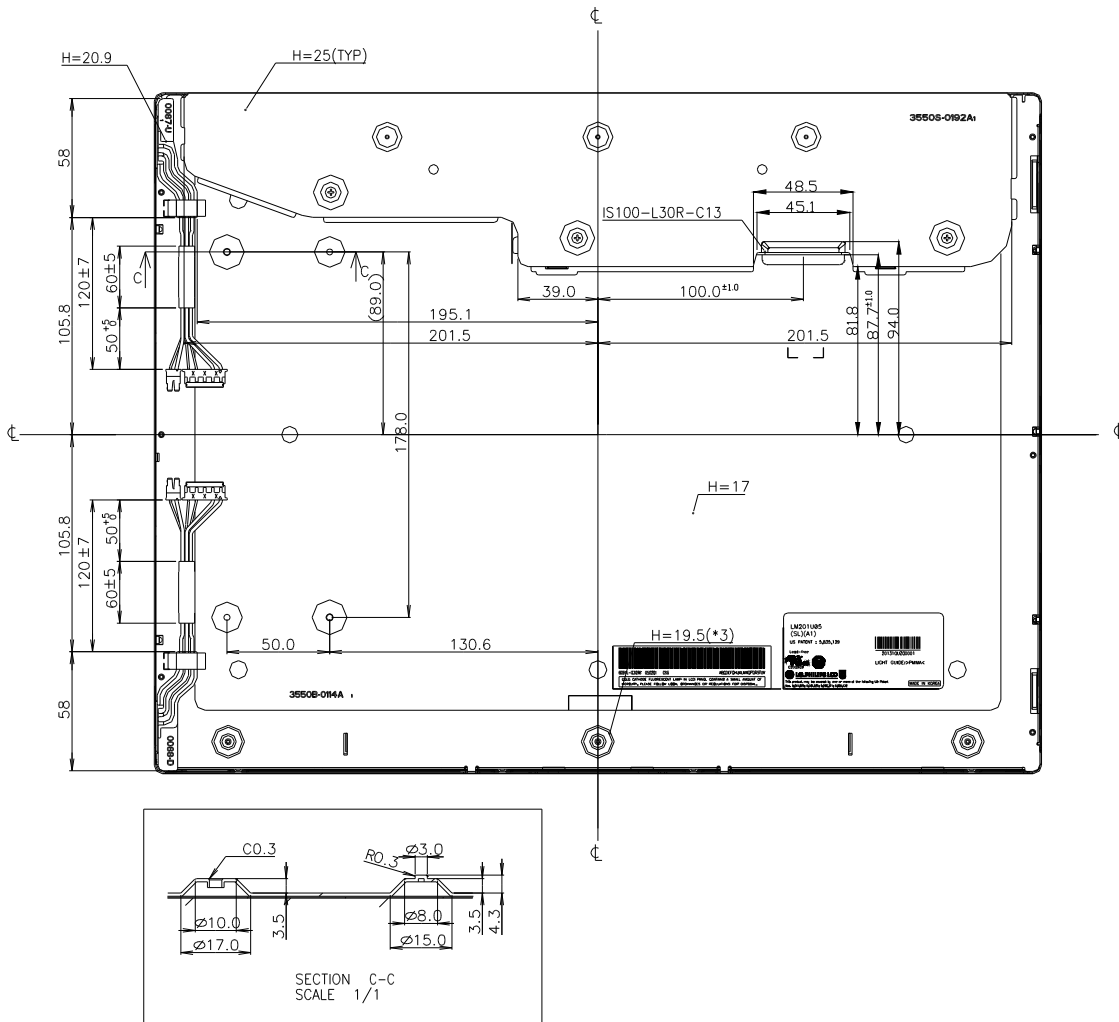

- NOTES
1. Unspecified tolerances are to be $\pm 0.5\text{mm}$.
 2. Both backlight wires and contraction tubes are excluded from outline dimensions.
 3. Tilt and partial disposition tolerance of display area are as following.
 - (1) Y-Direction : $IA-BI \leq 1.0\text{mm}$
 - (2) X-Direction : $IC-DI \leq 1.0\text{mm}$
 4. I/F Connector Specification : IS100-L30R-C23 or Compatible
 5. Lamp Connector Specification
 - BHR-05VS-1(JST) or Compatible
 - BHSR-02VS-1(JST) or Compatible
 6. Lamp(CCFL) lot No.is marked at backlight connector.

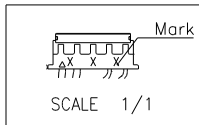
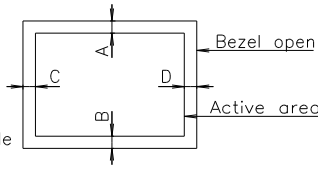

7. Do not wrap conductive tapes around the backlight wires.

Product Specification

6. Reliability

Environment test condition

No.	Test Item	Conditions
1	High temperature storage test	Ta= 60°C 240h
2	Low temperature storage test	Ta= -20°C 240h
3	High temperature operation test	Ta= 50°C 60%RH 240h
4	Low temperature operation test	Ta= 0°C 240h
5	Vibration test (non-operating)	Waveform : Random Vibration level : 1.0G RMS Bandwidth : 10 ~ 500Hz Duration : X,Y,Z 10min One time each direction
6	Shock test (non-operating)	Shock level : 100G Waveform: half sine wave, 2ms Direction : ±X, ±Y, ±Z One time each direction
7	Altitude storage / shipment operating	0 - 40,000 feet(12,192m) 0 - 12,000 feet (3657.6m)

{ Result Evaluation Criteria }

There should be no change which might affect the practical display function when the display quality test is conducted under normal operating condition.

Product Specification

7. International Standards

7-1. Safety

- a) UL 60950-1:2003, First Edition, Underwriters Laboratories, Inc., Standard for Safety of Information Technology Equipment.
- b) CAN/CSA C22.2, No. 60950-1-03 1st Ed. April 1, 2003, Canadian Standards Association, Standard for Safety of Information Technology Equipment.
- c) EN 60950-1:2001, First Edition, European Committee for Electrotechnical Standardization(CENELEC) European Standard for Safety of Information Technology Equipment.

7-2. EMC

- a) ANSI C63.4 "Methods of Measurement of Radio-Noise Emissions from Low-Voltage Electrical and Electrical Equipment in the Range of 9kHz to 40GHz. "American National Standards Institute(ANSI), 1992
- b) C.I.S.P.R. "Limits and Methods of Measurement of Radio Interface Characteristics of Information Technology Equipment." International Special Committee on Radio Interference.
- c) EN 55022 "Limits and Methods of Measurement of Radio Interface Characteristics of Information Technology Equipment." European Committee for Electrotechnical Standardization.(CENELEC), 1998 (Including A1: 2000)

Notes : The LM201U05-SLA3 is applied ROHS

Product Specification

8. Packing

8-1. Designation of Lot Mark

a) Lot Mark

A	B	C	D	E	F	G	H	I	J	K	L	M
---	---	---	---	---	---	---	---	---	---	---	---	---

A,B,C : SIZE(INCH)
E : MONTH

D : YEAR
F ~ M : SERIAL NO.

Note

1. YEAR

Year	2001	2002	2003	2004	2005	2006	2007	2008	2009	2010
Mark	1	2	3	4	5	6	7	8	9	0

2. MONTH

Month	Jan	Feb	Mar	Apr	May	Jun	Jul	Aug	Sep	Oct	Nov	Dec
Mark	1	2	3	4	5	6	7	8	9	A	B	C

b) Location of Lot Mark

Serial No. is printed on the label. The label is attached to the backside of the LCD module.
This is subject to change without prior notice.

8-2. Packing Form

a) Package quantity in one box : 5 pcs

b) Box Size : 530mm × 307mm × 453mm

Product Specification

9. PRECAUTIONS

Please pay attention to the following when you use this TFT LCD module.

9-1. MOUNTING PRECAUTIONS

- (1) You must mount a module using holes arranged in four corners or four sides.
- (2) You should consider the mounting structure so that uneven force(ex. Twisted stress) is not applied to the module.
And the case on which a module is mounted should have sufficient strength so that external force is not transmitted directly to the module.
- (3) Please attach a transparent protective plate to the surface in order to protect the polarizer.
Transparent protective plate should have sufficient strength in order to resist external force.
- (4) You should adopt radiation structure to satisfy the temperature specification.
- (5) Acetic acid type and chlorine type materials for the cover case are not describe because the former generates corrosive gas of attacking the polarizer at high temperature and the latter causes circuit break by electro-chemical reaction.
- (6) Do not touch, push or rub the exposed polarizers with glass, tweezers or anything harder than HB pencil lead. And please do not rub with dust clothes with chemical treatment.
Do not touch the surface of polarizer for bare hand or greasy cloth.(Some cosmetics are determined to the polarizer.)
- (7) When the surface becomes dusty, please wipe gently with absorbent cotton or other soft materials like chamois soaks with petroleum benzene. Normal-hexane is recommended for cleaning the adhesives used to attach front / rear polarizers. Do not use acetone, toluene and alcohol because they cause chemical damage to the polarizer.
- (8) Wipe off saliva or water drops as soon as possible. Their long time contact with polarizer causes deformations and color fading.
- (9) Do not open the case because inside circuits do not have sufficient strength.

9-2. OPERATING PRECAUTIONS

- (1) The spike noise causes the mis-operation of circuits. It should be lower than following voltage :
 $V = \pm 200\text{mV}$ (Over and under shoot voltage)
- (2) Response time depends on the temperature.(In lower temperature, it becomes longer.)
- (3) Brightness depends on the temperature. (In lower temperature, it becomes lower.)
And in lower temperature, response time(required time that brightness is stable after turned on) becomes longer.
- (4) Be careful for condensation at sudden temperature change. Condensation makes damage to polarizer or electrical contacted parts. And after fading condensation, smear or spot will occur.
- (5) When fixed patterns are displayed for a long time, remnant image is likely to occur.
- (6) Module has high frequency circuits. Sufficient suppression to the electromagnetic interference shall be done by system manufacturers. Grounding and shielding methods may be important to minimized the interference.
- (7) Please do not give any mechanical and/or acoustical impact to LCM.
Otherwise, LCM can not be operated its full characteristics perfectly.

Product Specification

9-3. ELECTROSTATIC DISCHARGE CONTROL

Since a module is composed of electronic circuits, it is not strong to electrostatic discharge. Make certain that treatment persons are connected to ground through wrist band etc. And don't touch interface pin directly.

9-4. PRECAUTIONS FOR STRONG LIGHT EXPOSURE

Strong light exposure causes degradation of polarizer and color filter.

9-5. STORAGE

When storing modules as spares for a long time, the following precautions are necessary.

- (1) Store them in a dark place. Do not expose the module to sunlight or fluorescent light. Keep the temperature between 5°C and 35°C at normal humidity.
- (2) The polarizer surface should not come in contact with any other object.
It is recommended that they be stored in the container in which they were shipped.

9-6. HANDLING PRECAUTIONS FOR PROTECTION FILM

- (1) The protection film is attached to the bezel with a small masking tape
When the protection film is peeled off, static electricity is generated between the film and polarizer.
This should be peeled off slowly and carefully by people who are electrically grounded and with well ion-blown equipment or in such a condition, etc.
- (2) When the module with protection film attached is stored for a long time, sometimes there remains a very small amount of glue still on the bezel after the protection film is peeled off.
- (3) You can remove the glue easily. When the glue remains on the bezel or its vestige is recognized, please wipe them off with absorbent cotton waste or other soft material like chamois soaked with normal-hexane.

Product Specification

APPENDIX 1. REQUIRED SIGNAL ASSIGNMENT FOR FlatLink(TI:SN75LVDS83) Transmitter

Pin #	Pin Name	Require Signal	Pin #	Pin Name	Require Signal
1	VCC	Power Supply for TTL Input	29	GND	Ground pin for TTL
2	D5	TTL Input (R7)	30	D26	TTL Input (DE)
3	D6	TTL Input (R5)	31	T _X CLKIN	TTL Level clock Input
4	D7	TTL Input (G0)	32	PWR DWN	Power Down Input
5	GND	Ground pin for TTL	33	PLL GND	Ground pin for PLL
6	D8	TTL Input (G1)	34	PLL VCC	Power Supply for PLL
7	D9	TTL Input (G2)	35	PLL GND	Ground pin for PLL
8	D10	TTL Input (G6)	36	LVDS GND	Ground pin for LVDS
9	VCC	Power Supply for TTL Input	37	TxOUT3 +	Positive LVDS differential data output 3
10	D11	TTL Input (G7)	38	TxOUT3 –	Negative LVDS differential data output 3
11	D12	TTL Input (G3)	39	T _X CLKOUT +	Positive LVDS differential clock output
12	D13	TTL Input (G4)	40	T _X CLKOUT –	Negative LVDS differential clock output
13	GND	Ground pin for TTL	41	T _X OUT2 +	Positive LVDS differential data output 2
14	D14	TTL Input (G5)	42	T _X OUT2 –	Negative LVDS differential data output 2
15	D15	TTL Input (B0)	43	LVDS GND	Ground pin for LVDS
16	D16	TTL Input (B6)	44	LVDS VCC	Power Supply for LVDS
17	VCC	Power Supply for TTL Input	45	T _X OUT1 +	Positive LVDS differential data output 1
18	D17	TTL Input (B7)	46	T _X OUT1 –	Negative LVDS differential data output 1
19	D18	TTL Input (B1)	47	T _X OUT0 +	Positive LVDS differential data output 0
20	D19	TTL Input (B2)	48	T _X OUT0 –	Negative LVDS differential data output 0
21	GND	Ground pin for TTL Input	49	LVDS GND	Ground pin for LVDS
22	D20	TTL Input (B3)	50	D27	TTL Input (R6)
23	D21	TTL Input (B4)	51	D0	TTL Input (R0)
24	D22	TTL Input (B5)	52	D1	TTL Input (R1)
25	D23	TTL Input (RSVD)	53	GND	Ground pin for TTL
26	VCC	Power Supply for TTL Input	54	D2	TTL Input (R2)
27	D24	TTL Input (HSYNC)	55	D3	TTL Input (R3)
28	D25	TTL Input (VSYNC)	56	D4	TTL Input (R4)

Notes : Refer to LVDS Transmitter Data Sheet for detail descriptions.