

Product Specification

SPECIFICATION FOR APPROVAL

- () Preliminary Specification
 (◆) Final Specification

Title	17.0" SXGA TFT LCD
-------	---------------------------

BUYER	
MODEL	

SUPPLIER	LG.Philips LCD Co., Ltd.
*MODEL	LM170E03
SUFFIX	TLG3

*When you obtain standard approval,
please use the above model name without suffix

SIGNATURE	DATE
/	_____
/	_____
/	_____

APPROVED BY	DATE
_____	_____
REVIEWED BY	_____
_____	_____
PREPARED BY	_____
_____	_____

Please return 1 copy for your confirmation with your signature and comments.

**Product Engineering Dept.
LG. Philips LCD Co., Ltd**

Product Specification

CONTENTS

NO.	ITEM	Page
-	COVER	1
-	CONTENTS	2
-	RECORD OF REVISIONS	3
1	GENERAL DESCRIPTION	4
2	ABSOLUTE MAXIMUM RATINGS	5
3	ELECTRICAL SPECIFICATIONS	6
3-1	ELECTRICAL CHARACTERISTICS	6
3-2	INTERFACE CONNECTIONS	9
3-3	SIGNAL TIMING SPECIFICATIONS	15
3-4	SIGNAL TIMING WAVEFORMS	16
3-5	COLOR INPUT DATA REFERANCE	17
3-6	POWER SEQUENCE	18
3-7	VCC POWER DIP CONDITION	19
4	OPTICAL SPECIFICATIONS	20
5	MECHANICAL CHARACTERISTICS	25
6	RELIABILITY	28
7	INTERNATIONAL STANDARDS	29
7-1	SAFETY	29
7-2	EMC	29
8	PACKING	30
8-1	DESIGNATION OF LOT MARK	30
8-2	PACKING FORM	30
9	PRECAUTIONS	31

Product Specification

RECORD OF REVISIONS

Revision No	Date	Page	Description
Ver 0.1	Nov. 30, 2007		Preliminary Specifications
Ver 0.2	Jan. 24, 2008	4,25 27	Update for Weight 1890g(typ) → 1600g(typ) Update for Rear view -Label change
Ver 1.0	Feb. 27, 2008		Final Specification

Product Specification

1. General Description

The LM170E03-TLG3 is a Color Active Matrix Liquid Crystal Display with an integral Cold Cathode Fluorescent Lamp(CCFL) backlight system. The matrix employs a-Si Thin Film Transistor as the active element. It is a transmissive type display operating in the normally white mode. This TFT-LCD has a 17.0 inch diagonal measured active display area with SXGA resolution(1024 vertical by 1280 horizontal pixel array) Each pixel is divided into Red, Green and Blue sub-pixels or dots which are arranged in vertical stripes. Gray scale or the brightness of the sub-pixel color is determined with a 8-bit gray scale signal for each dot, thus, presenting a palette of more than 16.7M colors with A-FRC(Advanced-Frame Rate Control).

The LM170E03-TLG3 has been designed to apply the interface method that enables low power, high speed, low EMI. FPD Link or compatible must be used as a LVDS(Low Voltage Differential Signaling) chip. The LM170E03-TLG3 is intended to support applications where thin thickness, wide viewing angle, low power are critical factors and graphic displays are important. In combination with the vertical arrangement of the sub-pixels, the LM170E03-TLG3 characteristics provide an excellent flat panel display for office automation products such as monitors.

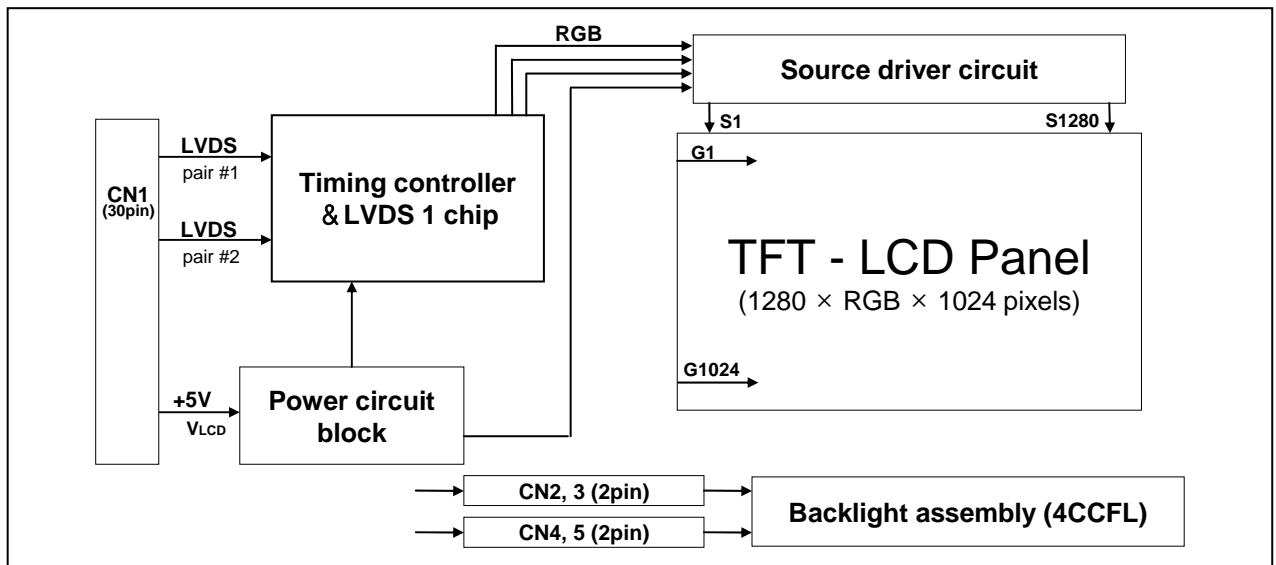

Figure 1. Block diagram

General Features

Active screen size	17.0 inch (43.27cm) diagonal
Outline Dimension	358.5(H) x 296.5(V) x 16.0(D) mm(Typ.)
Pixel Pitch	0.264 mm x 0.264 mm
Pixel Format	1280 horiz. by 1024 vert. Pixels. RGB stripe arrangement
Display Colors	16.7M colors
Luminance, white	300 cd/m ² (Typ. Center 1 point)
Power Consumption	21.85 Watts(Typ.)
Weight	1600g (Typ.)
Display operating mode	Transmissive mode, normally white
Surface treatments	Hard coating (3H), Anti-glare treatment of the front polarizer

Product Specification

2. Absolute maximum ratings

The following are maximum values which, if exceeded, may cause faulty operation or damage to the unit.

Table 1. Absolute Maximum Ratings

Parameter	Symbol	Values		Units	Notes
		Min.	Max.		
Power Supply Input Voltage	V_{CC}	- 0.3	+ 5.5	V_{dc}	At 25 °C
Operating Temperature	T_{OP}	0	+ 50	°C	1
Storage Temperature	T_{ST}	- 20	+ 60	°C	1
Operating Ambient Humidity	H_{OP}	10	+ 90	%RH	1
Storage Humidity	H_{ST}	10	+ 90	%RH	1

Note : 1. Temperature and relative humidity range are shown in the figure below.
 Wet bulb temperature should be 39 °C Max, and no condensation of water.

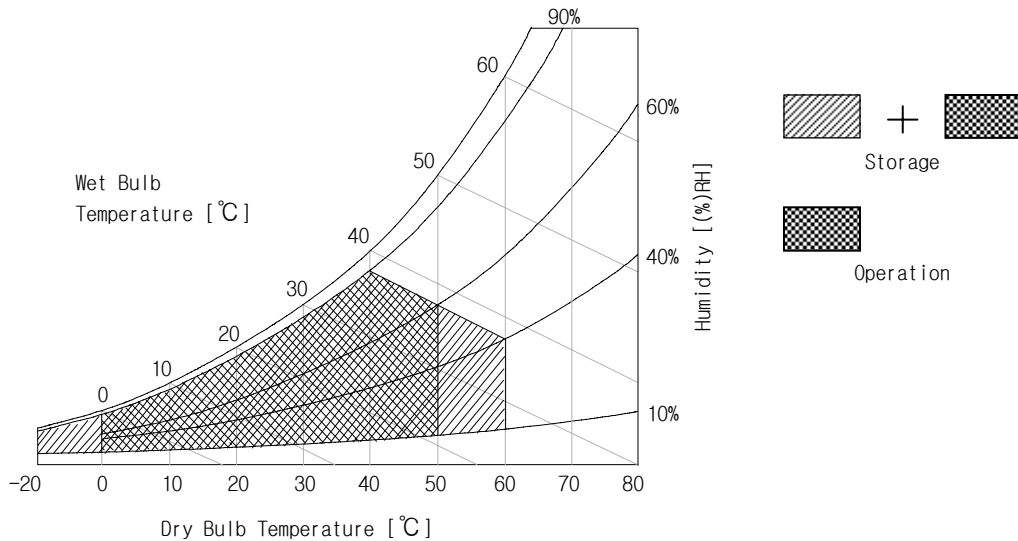

Figure 2. Temperature and relative humidity

Product Specification

3. Electrical specifications

3-1. Electrical characteristics

The LM170E03-TLG3 requires two power inputs. One is employed to power the LCD electronics and to drive the TFT array and liquid crystal. Another which powers the CCFL, is typically generated by an inverter. The inverter is an external unit to the LCD.

Table 2_1. ELECTRICAL CHARACTERISTICS

Parameter	Symbol	Values			Unit	Notes
		Min	Typ	Max		
MODULE :						
Power Supply Input Voltage	V _{LCD}	4.5	5.0	5.5	Vdc	
Power Supply Input Current	I _{LCD}	-	790	910	mA	1
		-	950	1090	mA	2
Power Consumption	P _{LCD}	-	3.95	4.55	Watt	1
Rush current	I _{RUSH}	-	-	3	A	3

Note :

1. The specified current and power consumption are under the $V_{LCD}=5.0V$, $25 \pm 2^{\circ}C$, $f_v=60Hz$ condition whereas mosaic pattern(8 x 6) is displayed and f_v is the frame frequency.
2. The current is specified at the maximum current pattern.
3. The duration of rush current is about 2ms and rising time of power Input is $500\mu s \pm 20\%$.(min.).

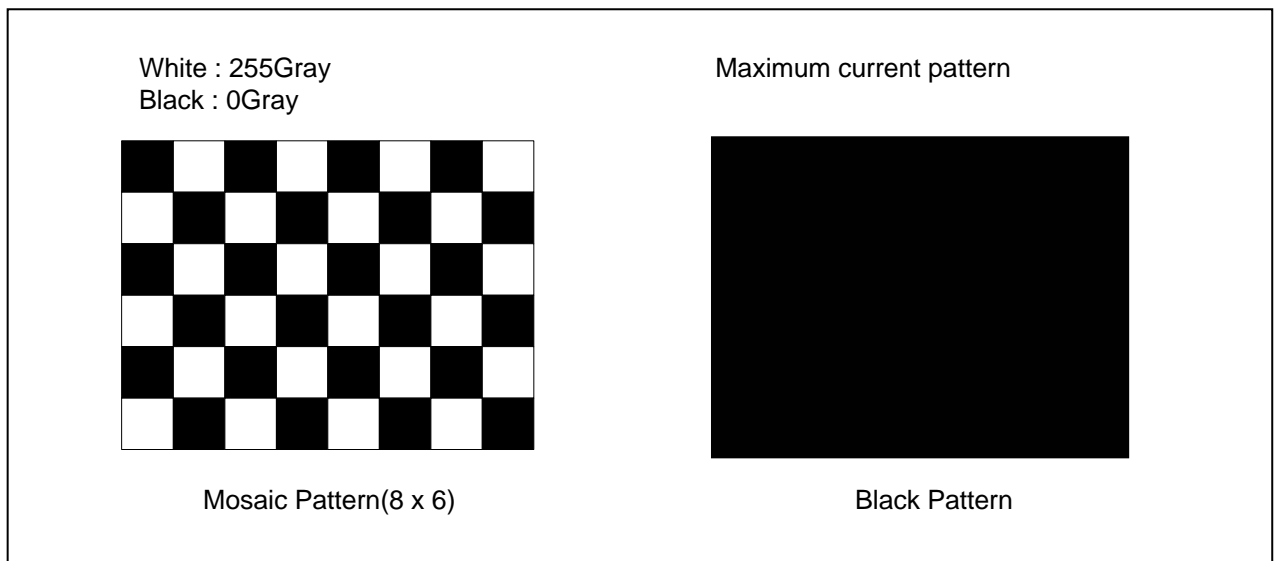

Product Specification

Table 2_2. ELECTRICAL CHARACTERISTICS

Parameter	Symbol	Values			Unit	Notes
		Min	Typ	Max		
LAMP :						
Operating Voltage	V _{BL}	628	640	745	V _{RMS}	1, 2
Operating Current	I _{BL}	2.5	7.0	7.5	mA _{RMS}	1
Established Starting Voltage	V _S					1, 3
	at 25 °C			1000	V _{RMS}	
	at 0 °C			1250	V _{RMS}	
Operating Frequency	f _{BL}	40	60	70	kHz	4
Discharge Stabilization Time	T _S			3	Min	1, 5
Power Consumption	P _{BL}		17.90	19.70	W	6
Life Time		50,000			Hrs	1, 7

Note : The design of the inverter must have specifications for the lamp in LCD Assembly.

The performance of the Lamp in LCM, for example life time or brightness, is extremely influenced by the characteristics of the DC-AC inverter. So all the parameters of an inverter should be carefully designed so as not to produce too much leakage current from high-voltage output of the inverter.

When you design or order the inverter, please make sure unwanted lighting caused by the mismatch of the lamp and the inverter (no lighting, flicker, etc) never occurs. When you confirm it, the LCD-Assembly should be operated in the same condition as installed in you instrument.

※ Do not attach a conducting tape to lamp connecting wire.

If the lamp wire attach to a conducting tape, TFT-LCD Module has a low luminance and the inverter has abnormal action. Because leakage current is occurred between lamp wire and conducting tape.

- Specified values are for a single lamp.
- Operating voltage is measured at $25 \pm 2^\circ\text{C}$. The variance of the voltage is $\pm 10\%$.
- The voltage above V_S should be applied to the lamps for more than 1 second for start-up.
(Inverter open voltage must be more than lamp starting voltage.)
Otherwise, the lamps may not be turned on. The used lamp current is the lamp typical current.
- Lamp frequency may produce interface with horizontal synchronous frequency and as a result this may cause beat on the display. Therefore lamp frequency shall be as away possible from the horizontal synchronous frequency and from its harmonics in order to prevent interference.
- Let's define the brightness of the lamp after being lighted for 5 minutes as 100%.
 T_S is the time required for the brightness of the center of the lamp to be not less than 95%.
- The lamp power consumption shown above does not include loss of external inverter.
The used lamp current is the lamp typical current. ($P_{BL} = V_{BL} \times I_{BL} \times N_{Lamp}$)
- The life is determined as the time at which brightness of the lamp is 50% compared to that of initial value at the typical lamp current on condition of continuous operating at $25 \pm 2^\circ\text{C}$.

Product Specification

8. The output of the inverter must have symmetrical(negative and positive) voltage waveform and symmetrical current waveform (Unsymmetrical ratio is less than 10%). Please do not use the inverter which has unsymmetrical voltage and unsymmetrical current and spike wave. Requirements for a system inverter design, which is intended to have a better display performance, a better power efficiency and a more reliable lamp, are following. It shall help increase the lamp lifetime and reduce leakage current.
- a. The asymmetry rate of the inverter waveform should be less than 10%.
 - b. The distortion rate of the waveform should be within $\sqrt{2} \pm 10\%$.
- * Inverter output waveform had better be more similar to ideal sine wave.

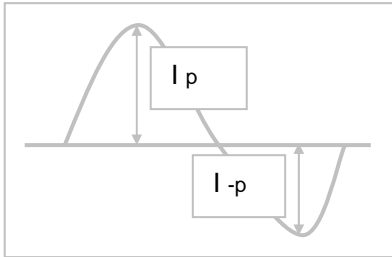

* Asymmetry rate:

$$\frac{|I_p - I_{-p}|}{I_{rms}} \times 100\%$$

* Distortion rate

$$I_p \text{ (or } I_{-p}) / I_{rms}$$

9. The inverter which is combined with this LCM, is highly recommended to connect coupling(ballast) condenser at the high voltage output side. When you use the inverter which has not coupling(ballast) condenser, it may cause abnormal lamp lighting because of biased mercury as time goes.
10. In case of edgy type back light with over 4 parallel lamps, input current and voltage wave form should be synchronized

Product Specification

3-2. Interface Connections

Interface chip must be used LVDS, part No. SN75LVDS83 (Tx, Texas Instrument) or compatible. This LCD employs a interface connection, a 30 pin connector is used for the module electronics interface. Four 2pin connectors are used for the integral backlight system. The electronics interface connector is a model IS100-L30B-C23 manufactured by UJU or 187024-30091 manufactured by P-TWO. And mating connector is FI-X30H and FI-X30HL or it's compatible manufactured by JAE. The pin configuration for the connector is shown in the table 3 and the signal mapping with LVDS transmitter is shown in the table 4.

Table 3. Module connector pin configuration

Pin No	Symbol	Description
1	RxO0-	LVDS Signal of Odd Channel 0(-)
2	RxO0+	LVDS Signal of Odd Channel 0(+)
3	RxO1-	LVDS Signal of Odd Channel 1(-)
4	RxO1+	LVDS Signal of Odd Channel 1(+)
5	RxO2-	LVDS Signal of Odd Channel 2(-)
6	RxO2+	LVDS Signal of Odd Channel 2(+)
7	GND	Ground
8	RxOC-	LVDS Signal of Odd Channel Clock(-)
9	RxOC+	LVDS Signal of Odd Channel Clock(+)
10	RxO3-	LVDS Signal of Odd Channel 3(-)
11	RxO3+	LVDS Signal of Odd Channel 3(+)
12	RxE0-	LVDS Signal of Even Channel 0(-)
13	RxE0+	LVDS Signal of Even Channel 0(+)
14	GND	Ground
15	RxE1-	LVDS Signal of Even Channel 1(-)
16	RxE1+	LVDS Signal of Even Channel 1(+)
17	GND	Ground
18	RxE2-	LVDS Signal of Even Channel 2(-)
19	RxE2+	LVDS Signal of Even Channel 2(+)
20	RxEC-	LVDS Signal of Even Channel Clock(-)
21	RxEC+	LVDS Signal of Even Channel Clock(+)
22	RxE3-	LVDS Signal of Even Channel 3(-)
23	RxE3+	LVDS Signal of Even Channel 3(+)
24	GND	Ground
25	NC	No connection(For LCD internal use only)
26	NC	No connection(For LCD internal use only)
27	PWM_OUT	PWM_OUT signal for control burst frequency of inverter
28	VCC	Power supply (5.0V Typ.)
29	VCC	Power supply (5.0V Typ.)
30	VCC	Power supply (5.0V Typ.)

First Pixel Data

Second Pixel Data

Product Specification

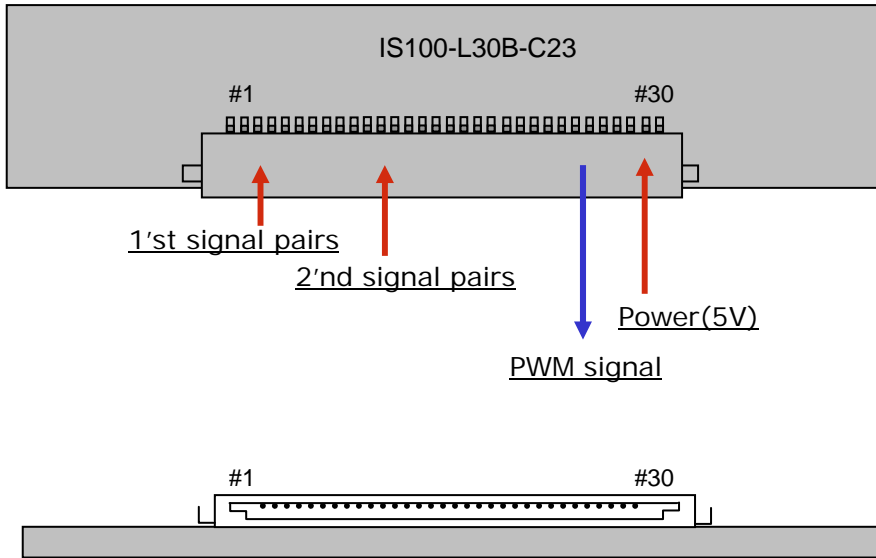

Rear view of LCM

[Figure 4] Connector diagram

- Notes:
1. All GND(ground) pins should be connected together and should also be connected to the LCD's metal frame.
 2. All V_{CC} (power input) pins should be connected together.
 3. All NC pins should be separated from other signal or power.
 4. PWM_OUT signal controls the burst frequency of a inverter.
 This signal is synchronized with vertical frequency,
 it's frequency is 3 times of vertical frequency, and it's duty ratio is 50%.
 If you don't use this pin, it is no connection.

Product Specification

Table 4. Required signal assignment for Flat Link (TI:SN75LVDS83) Transmitter

Pin	Pin Name	Require Signal	Pin	Pin Name	Require Signal
1	VCC	Power Supply for TTL Input	29	GND	Ground pin for TTL
2	D5	TTL Input(R7)	30	D26	TTL Input(DE)
3	D6	TTL Input(R5)	31	TxCLKIN	TTL Level clock Input
4	D7	TTL Input(G0)	32	PWR DWN	Power Down Input
5	GND	Ground pin for TTL	33	PLL GND	Ground pin for PLL
6	D8	TTL Input(G1)	34	PLL VCC	Power Supply for PLL
7	D9	TTL Input(G2)	35	PLL GND	Ground pin for PLL
8	D10	TTL Input(G6)	36	LVDS GND	Ground pin for LVDS
9	VCC	Power Supply for TTL Input	37	TxOUT3+	Positive LVDS differential data output3
10	D11	TTL Input(G7)	38	TxOUT3-	Negative LVDS differential data output3
11	D12	TTL Input(G3)	39	TxCLKOUT+	Positive LVDS differential clock output
12	D13	TTL Input(G4)	40	TxCLKOUT-	Negative LVDS differential clock output
13	GND	Ground pin for TTL	41	TxOUT2+	Positive LVDS differential data output2
14	D14	TTL Input(G5)	42	TxOUT2-	Negative LVDS differential data output2
15	D15	TTL Input(B0)	43	LVDS GND	Ground pin for LVDS
16	D16	TTL Input(B6)	44	LVDS VCC	Power Supply for LVDS
17	VCC	Power Supply for TTL Input	45	TxOUT1+	Positive LVDS differential data output1
18	D17	TTL Input(B7)	46	TxOUT1-	Negative LVDS differential data output1
19	D18	TTL Input(B1)	47	TxOUT0+	Positive LVDS differential data output0
20	D19	TTL Input(B2)	48	TxOUT0-	Negative LVDS differential data output0
21	GND	Ground pin for TTL Input	49	LVDS GND	Ground pin for TTL
22	D20	TTL Input(B3)	50	D27	TTL Input(R6)
23	D21	TTL Input(B4)	51	D0	TTL Input(R0)
24	D22	TTL Input(B5)	52	D1	TTL Input(R1)
25	D23	TTL Input(RSVD)	53	GND	Ground pin for TTL
26	VCC	Power Supply for TTL Input	54	D2	TTL Input(R2)
27	D24	TTL Input(HSYNC)	55	D3	TTL Input(R3)
28	D25	TTL Input(VSYNC)	56	D4	TTL Input(R4)

Notes : 1. Refer to LVDS Transmitter Data Sheet for detail descriptions.

2. 7 means MSB and 0 means LSB at R,G,B pixel data

Product Specification

LVDS Input characteristics

1. DC Specification

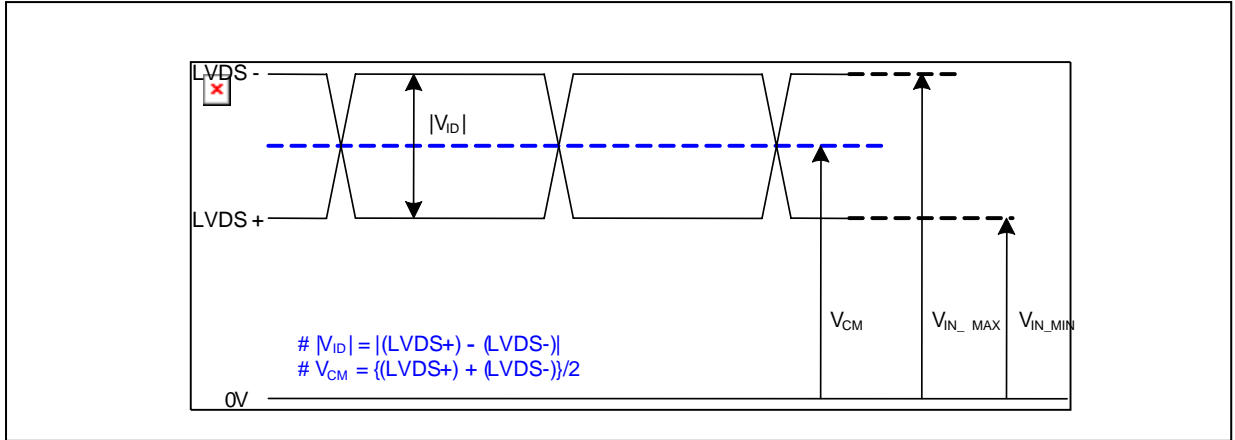

Description	Symbol	Min	Max	Unit	Notes
LVDS Differential Voltage	$ V_{ID} $	200	600	mV	-
LVDS Common mode Voltage	V_{CM}	0.6	1.8	V	-
LVDS Input Voltage Range	V_{IN}	0.3	2.1	V	-

2. AC Specification

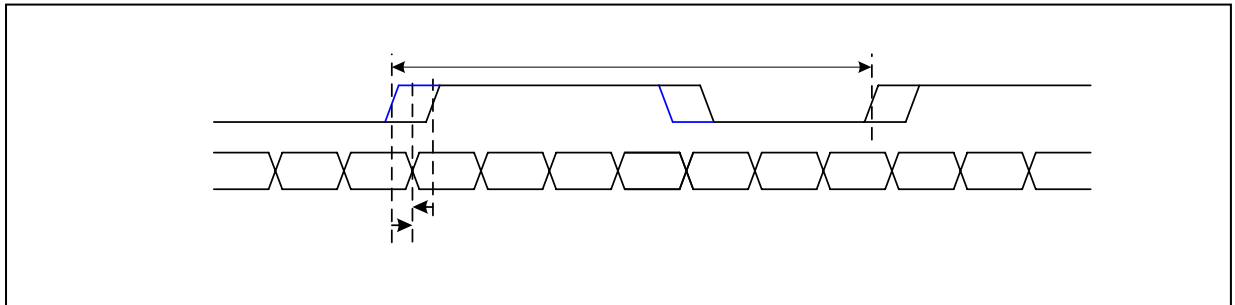

Description	Symbol	Min	Max	Unit	Notes
LVDS Clock to Data Skew Margin	t_{SKEW}	- 400	+ 400	ps	85MHz > Fclk ≥ 65MHz
	t_{SKEW}	- 600	+ 600	ps	65MHz > Fclk ≥ 25MHz
LVDS Clock to Clock Skew Margin (Even to Odd)	t_{SKEW_EO}	- 1/7	+ 1/7	T_{clk}	-
Maximum deviation of input clock frequency during SSC	F_{DEV}	-	± 3	%	-
Maximum modulation frequency of input clock during SSC	F_{MOD}	-	200	KHz	-

Product Specification

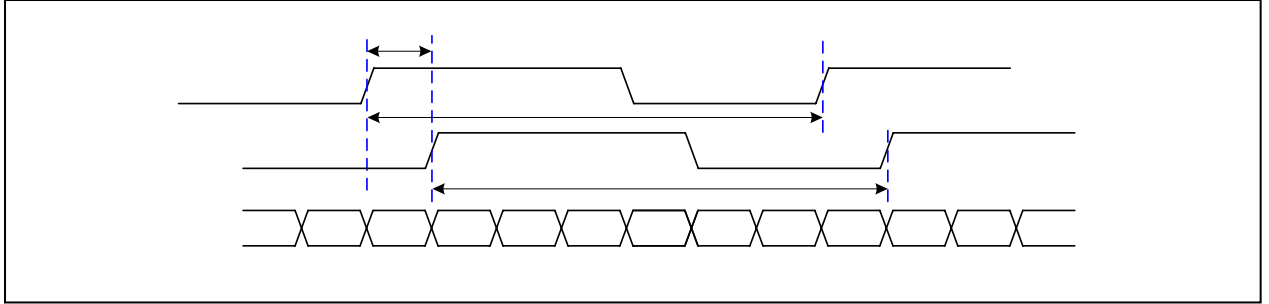

< Clock skew margin between channel >

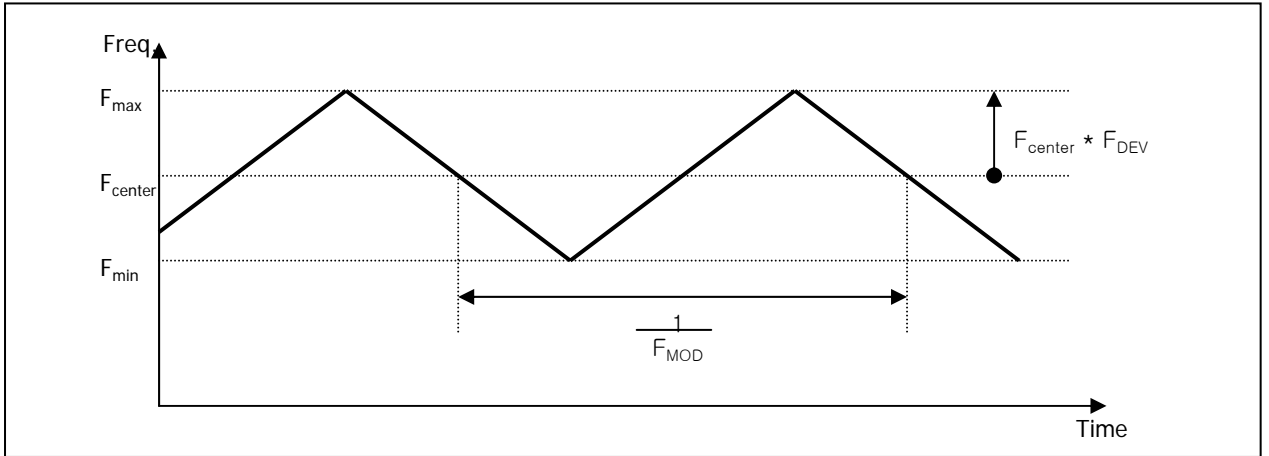

< Spread Spectrum >

3. Data Format

1) LVDS 2 Port

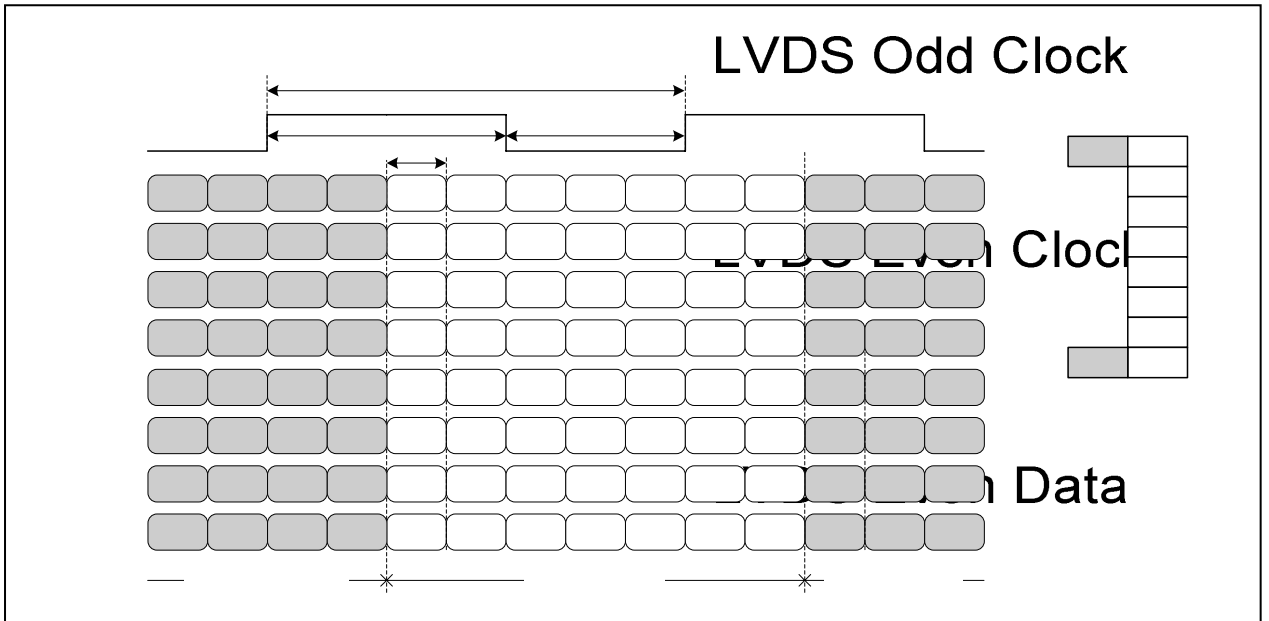

< LVDS Data Format >

Product Specification

The backlight interface connector is a model 35001HS-02LD(YEONHO) .
 The mating connector part number is 35001WR-02L or equivalent.
 The pin configuration for the connector is shown in the table 5.

Table 5. Backlight connector pin configuration

Pin	Symbol	Description	Notes
1	HV	High Voltage for lamp	1
2	LV	Low Voltage for lamp	1,2

Notes : 1. The high voltage side terminal is colored white or pink. The low voltage side terminal is White or Blue.
 2. The backlight ground should be common with LCD metal frame.

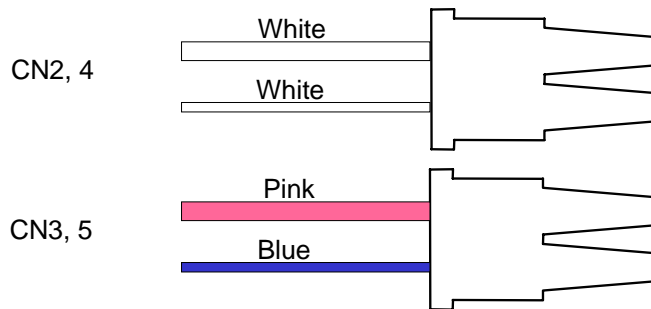

[Figure 5] Backlight connector view

Product Specification

3-3. Signal Timing Specifications

This is the signal timing required at the input of the LVDS Transmitter. All of the interface signal timing should be satisfied with the following specifications for its proper operation.

Table 6. Timing table

Parameter		Symbol	Min.	Typ.	Max.	Unit	Notes
D _{CLK}	Period	t _{CLK}	14.4	18.5	23.2	ns	Pixel frequency : Typ.108MHz
	Frequency	f _{CLK}	43.2	54.0	69.3	MHz	
Horizontal	Horizontal Valid	t _{HV}	640	640	640	t _{CLK}	
	H Period Total	t _{HP}	672	844	1022		
	Hsync Frequency	f _H	51.2	64.0	82.1	kHz	
Vertical	Vertical Valid	t _{VV}	1024	1024	1024	t _{HP}	
	V Period Total	t _{VP}	1032	1066	1536		
	Vsync Frequency	f _V	48	60	77	Hz	
DE (Data Enable)	DE Setup Time	t _{SI}	4	-	-	ns	For D _{CLK}
	DE Hold Time	t _{HI}	4	-	-		
Data	Data Setup Time	t _{SD}	4	-	-	ns	For D _{CLK}
	Data Hold Time	t _{HD}	4	-	-		

Note:

1. DE Only mode operation. The input of Hsync & Vsync signal does not have an effect on LCD normal operation.
2. The performance of the electro-optical characteristics may be influenced by variance of the vertical refresh rates.
3. Horizontal period should be even.

Product Specification

3-4. Signal Timing Waveforms

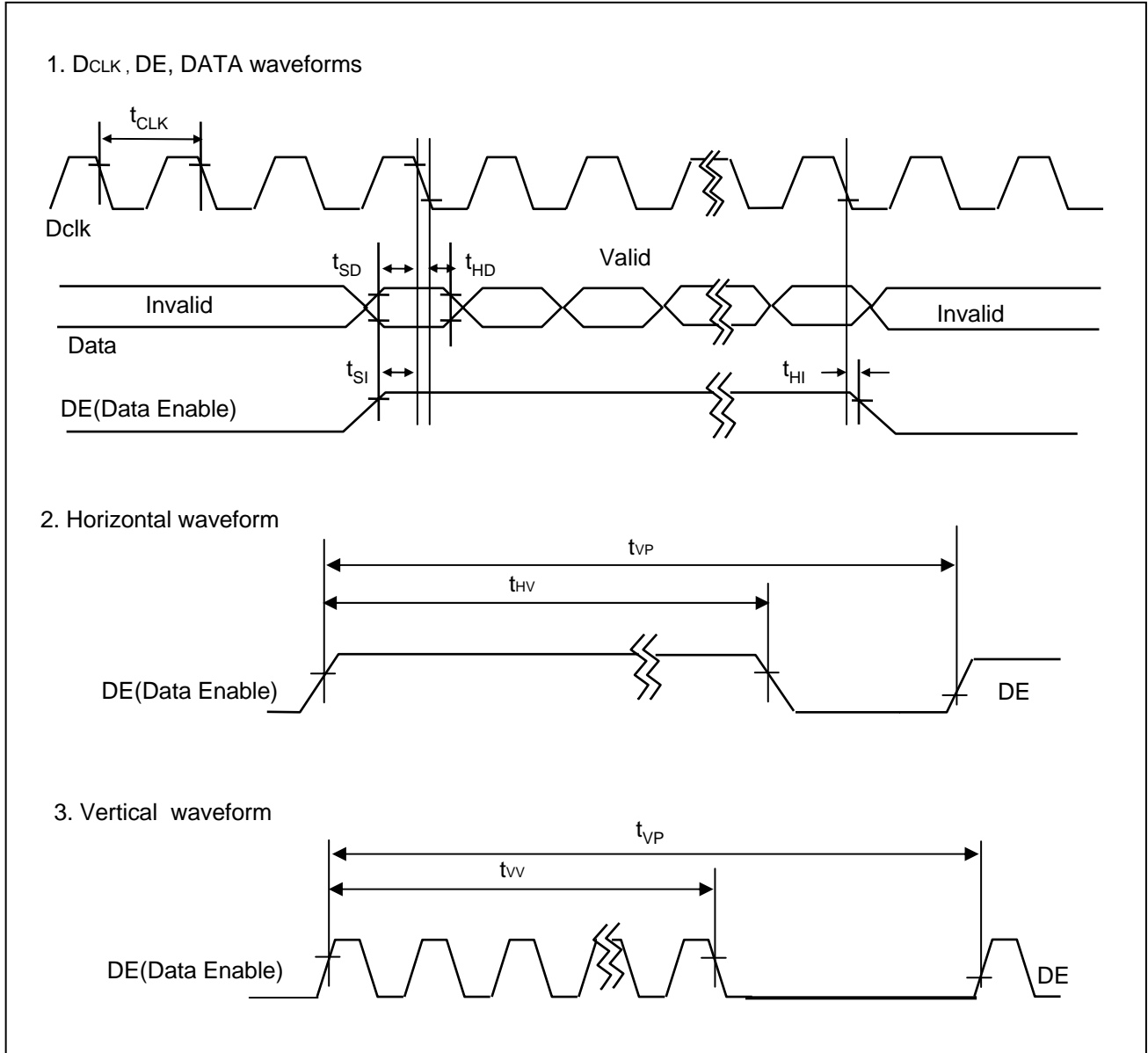

[Figure 6] Signal timing waveforms

Product Specification

3-5. Color Input Data Reference

The brightness of each primary color(red,green and blue) is based on the 8-bit gray scale data input for the color ; the higher the binary input, the brighter the color. The table below provides a reference for color versus data input.

Table 7. Color data reference

Color		Input color data																							
		Red								Green								Blue							
		MSB		LSB						MSB		LSB						MSB		LSB					
		R7	R6	R5	R4	R3	R2	R1	R0	G7	G6	G5	G4	G3	G2	G1	G0	B7	B6	B5	B4	B3	B2	B1	B0
Basic colors	Black	0	0	0	0	0	0	0	0	0	0	0	0	0	0	0	0	0	0	0	0	0	0	0	0
	Red(255)	1	1	1	1	1	1	1	1	0	0	0	0	0	0	0	0	0	0	0	0	0	0	0	0
	Green(255)	0	0	0	0	0	0	0	0	1	1	1	1	1	1	1	1	0	0	0	0	0	0	0	0
	Blue(255)	0	0	0	0	0	0	0	0	0	0	0	0	0	0	0	0	1	1	1	1	1	1	1	1
	Cyan	0	0	0	0	0	0	0	0	1	1	1	1	1	1	1	1	1	1	1	1	1	1	1	1
	Magenta	1	1	1	1	1	1	1	1	0	0	0	0	0	0	0	0	1	1	1	1	1	1	1	1
	Yellow	1	1	1	1	1	1	1	1	1	1	1	1	1	1	1	1	0	0	0	0	0	0	0	0
	White	1	1	1	1	1	1	1	1	1	1	1	1	1	1	1	1	1	1	1	1	1	1	1	1
Red	Red(000) dark	0	0	0	0	0	0	0	0	0	0	0	0	0	0	0	0	0	0	0	0	0	0	0	0
	Red(001)	0	0	0	0	0	0	0	1	0	0	0	0	0	0	0	0	0	0	0	0	0	0	0	0
	Red(002)	0	0	0	0	0	0	1	0	0	0	0	0	0	0	0	0	0	0	0	0	0	0	0	0
	:	:	:	:	:	:	:	:	:	:	:	:	:	:	:	:	:	:	:	:	:	:	:	:	:
	Red(253)	1	1	1	1	1	1	0	1	0	0	0	0	0	0	0	0	0	0	0	0	0	0	0	0
	Red(254)	1	1	1	1	1	1	1	0	0	0	0	0	0	0	0	0	0	0	0	0	0	0	0	0
	Red(255) bright	1	1	1	1	1	1	1	1	0	0	0	0	0	0	0	0	0	0	0	0	0	0	0	0
Green	Green(000)dark	0	0	0	0	0	0	0	0	0	0	0	0	0	0	0	0	0	0	0	0	0	0	0	0
	Green(001)	0	0	0	0	0	0	0	0	0	0	0	0	0	0	1	0	0	0	0	0	0	0	0	0
	Green(002)	0	0	0	0	0	0	0	0	0	0	0	0	0	1	0	0	0	0	0	0	0	0	0	0
	:	:	:	:	:	:	:	:	:	:	:	:	:	:	:	:	:	:	:	:	:	:	:	:	:
	Green(253)	0	0	0	0	0	0	0	1	1	1	1	1	1	1	0	1	0	0	0	0	0	0	0	0
	Green(254)	0	0	0	0	0	0	0	1	1	1	1	1	1	1	1	0	0	0	0	0	0	0	0	0
	Green(255)bright	0	0	0	0	0	0	0	1	1	1	1	1	1	1	1	1	0	0	0	0	0	0	0	0
Blue	Blue(000) dark	0	0	0	0	0	0	0	0	0	0	0	0	0	0	0	0	0	0	0	0	0	0	0	0
	Blue(001)	0	0	0	0	0	0	0	0	0	0	0	0	0	0	0	0	0	0	0	0	0	0	0	1
	Blue(002)	0	0	0	0	0	0	0	0	0	0	0	0	0	0	0	0	0	0	0	0	0	0	1	0
	:	:	:	:	:	:	:	:	:	:	:	:	:	:	:	:	:	:	:	:	:	:	:	:	:
	Blue(253)	0	0	0	0	0	0	0	0	0	0	0	0	0	0	0	1	1	1	1	1	1	1	0	1
	Blue(254)	0	0	0	0	0	0	0	0	0	0	0	0	0	0	0	1	1	1	1	1	1	1	1	0
	Blue(255) bright	0	0	0	0	0	0	0	0	0	0	0	0	0	0	0	1	1	1	1	1	1	1	1	1

Product Specification

3-6. Power Sequence

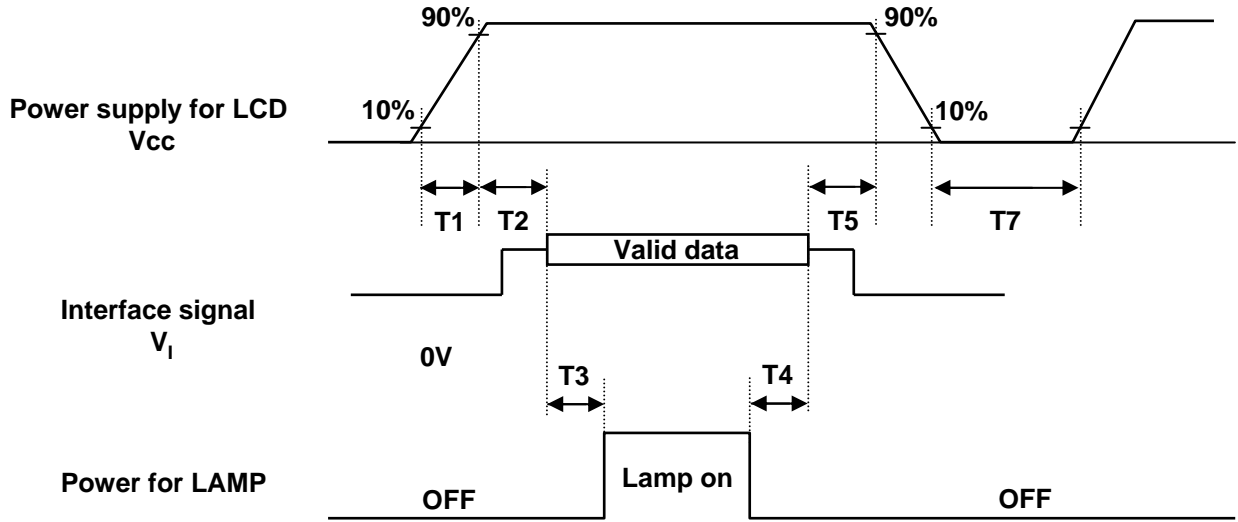

[Figure 7] Power sequence

Table 8. Power sequence time delay

Parameter	Values			Units
	Min.	Typ.	Max.	
T ₁	0.5	-	10	ms
T ₂	0.01	-	50	ms
T ₃	200	-	-	ms
T ₄	200	-	-	ms
T ₅	0.01	-	50	ms
T ₇	1	-	-	s

- Notes :
1. Please avoid floating state of interface signal at invalid period.
 2. When the interface signal is invalid, be sure to pull down the power supply for LCD V_{CC} to 0V.
 3. Lamp power must be turn on after power supply for LCD and interface signals are valid.

Product Specification

3-7. V_{CC} Power Dip Condition

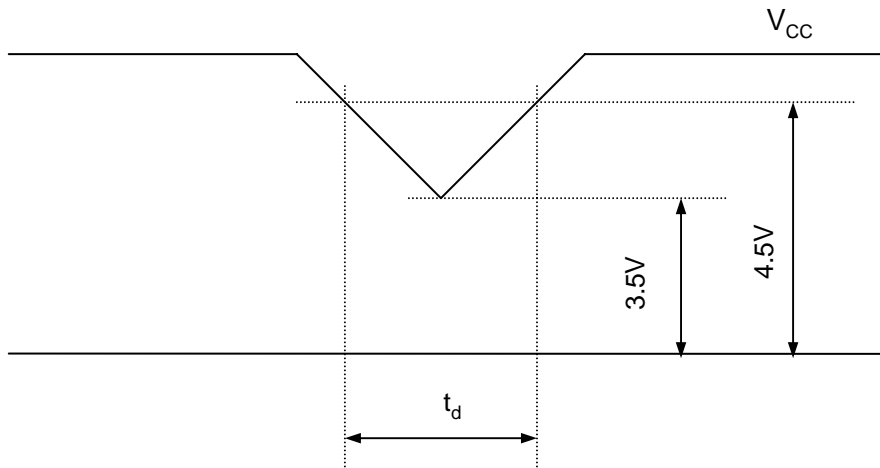

[Figure 8] Power dip condition

1) Dip condition

$$3.5V \leq V_{CC} < 4.5V, t_d \leq 20ms$$

2) V_{CC} < 3.5V

V_{CC}-dip conditions should also follow the Power On/Off conditions for supply voltage.

Product Specification

4. Optical Specifications

Optical characteristics are determined after the unit has been 'ON' and stable for approximately 30 minutes in a dark environment at 25 °C. The values specified are measured at an approximate distance 50cm from the LCD surface at a viewing angle of Φ and θ equal to 0 °.

Figure. 9 presents additional information concerning the measurement equipment and method.

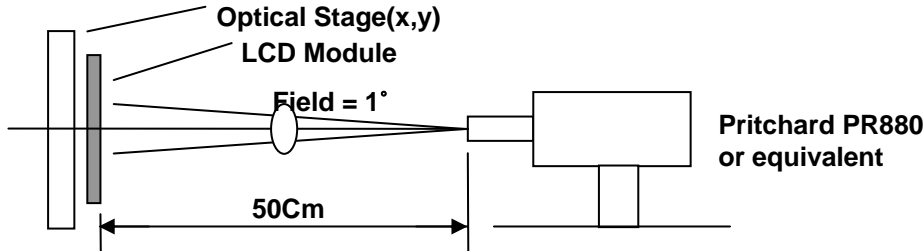

[Figure 9] Optical characteristic measurement equipment and method

Table 9. Optical characteristics (Ta=25 °C, V_{CC}=5.0V, f_V=60Hz Dclk=54MHz, I_{BL}=7.0mArms)

Parameter	Symbol	Values			Units	Notes
		Min.	Typ.	Max.		
Contrast ratio	CR	500	800	-		1
Surface luminance, white	L _{WH}	250	300	-	cd/m ²	2
Luminance uniformity	ΔL_g	75	-	-	%	3
Response time	Tr		5	10	ms	4
Rise time	Tr _R	-	1.2	2.4		
Decay time	Tr _D	-	3.8	7.6		
CIE color coordinates						
Red	XR	0.610	0.640	0.670		
	YR	0.305	0.335	0.365		
Green	XG	0.268	0.298	0.328		
	YG	0.578	0.608	0.638		
Blue	XB	0.117	0.147	0.177		
	YB	0.040	0.070	0.100		
White	XW	0.283	0.313	0.343		
	YW	0.299	0.329	0.359		
Viewing angle (by CR ≥ 10)				-		
X axis, right($\phi=0^\circ$)	θ_r	70	85	-	degree	5
X axis, left ($\phi=180^\circ$)	θ_l	70	85	-		
Y axis, up ($\phi=90^\circ$)	θ_u	60	75	-		
Y axis, down ($\phi=270^\circ$)	θ_d	70	85	-		
Viewing angle (by CR ≥ 5)				-		
X axis, right($\phi=0^\circ$)	θ_r	75	88	-	degree	
X axis, left ($\phi=180^\circ$)	θ_l	75	88	-		
Y axis, up ($\phi=90^\circ$)	θ_u	70	85	-		
Y axis, down ($\phi=270^\circ$)	θ_d	70	85	-		
Relative brightness						
Luminance uniformity - Angular dependence (TCO'03)		-	-	1.7		6 Figure 10
Crosstalk						
Color grayscale linearity	$\Delta u'v'$		0.018	1.5	%	Figure 13 7

Product Specification

Notes : 1. Contrast ratio(CR) is defined mathematically as :

$$\text{Contrast ratio} = \frac{\text{Surface luminance with all white pixels}}{\text{Surface luminance with all black pixels}}$$

2. Surface luminance is the center point across the LCD surface 50cm from the surface with all pixels displaying white. For more information see [Figure 10].
When $I_{BL}=7.0\text{mA}$, $L_{WH}=250\text{cd/m}^2(\text{Min.})$ $300\text{cd/m}^2(\text{Typ.})$
3. The uniformity in surface luminance , ΔL_g is determined by measuring L_{ON} at any point in test area. But the management of ΔL_g is determined by measuring L_{ON} at each test position 1 through 9, and then dividing the maximum L_{ON} of 9 points luminance by minimum L_{ON} of 9 points luminance. For more information see [Figure 10].
 $\Delta L_g = \text{Minimum } (L_{ON1}, L_{ON2}, \dots, L_{ON9}) \div \text{Maximum } (L_{ON1}, L_{ON2}, \dots, L_{ON9}) \times 100 (\%)$
4. Response time is the time required for the display to transition from white to black(Rise Time, Tr_R) and from black to white(Decay Time, Tr_D). For additional information see [Figure 11].
The sampling rate is 2,500 sample/sec.
5. Viewing angle is the angle at which the contrast ratio is greater than 10. The angles are determined for the horizontal or x axis and the vertical or y axis with respect to the z axis which is normal to the LCD surface. For more information see Figure 12 .
6. Gray scale specification

Table 10. Gray scale

Gray level	Luminance(%) (Typ.)
L0	0.10
L31	1.13
L63	4.93
L95	11.6
L127	21.3
L159	35.3
L191	54.8
L223	77.8
L255	100

Product Specification

Notes : 7. Color grayscale linearity , $\Delta u'v'$ is defined as

$$\sqrt{(u'_{A} - u'_{B})^2 + (v'_{A} - v'_{B})^2}$$

Where indices A and B are the two gray levels found to have the largest color differences between them.

i.e. get the largest $\Delta u'$ and $\Delta v'$ of each 6pairs of u' and v' and calculate $\Delta u'v'$.

- a. Test pattern : 100% full white pattern with a test pattern as shown below.
 Squares of 40mm by 40mm in size, filled with 255, 225, 195, 165, 135 and 105 grayscale steps should be arranged in the center of the screen.
- b. Test method
 First gray step : move a square of 255 gray level should be moved into the center of the screen and measure luminance and u' and v' coordinates.
 Next gray step : move a 255 gray square into the center and measure both luminance and u' and v' coordinates.
 The same procedure shall then be repeated for gray steps 195, 165, 135 and 105.

Color grayscale linearity

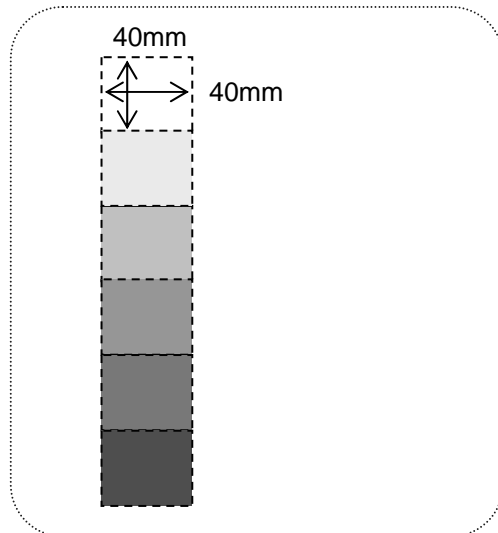

Product Specification

Figure 10. Luminance measuring point

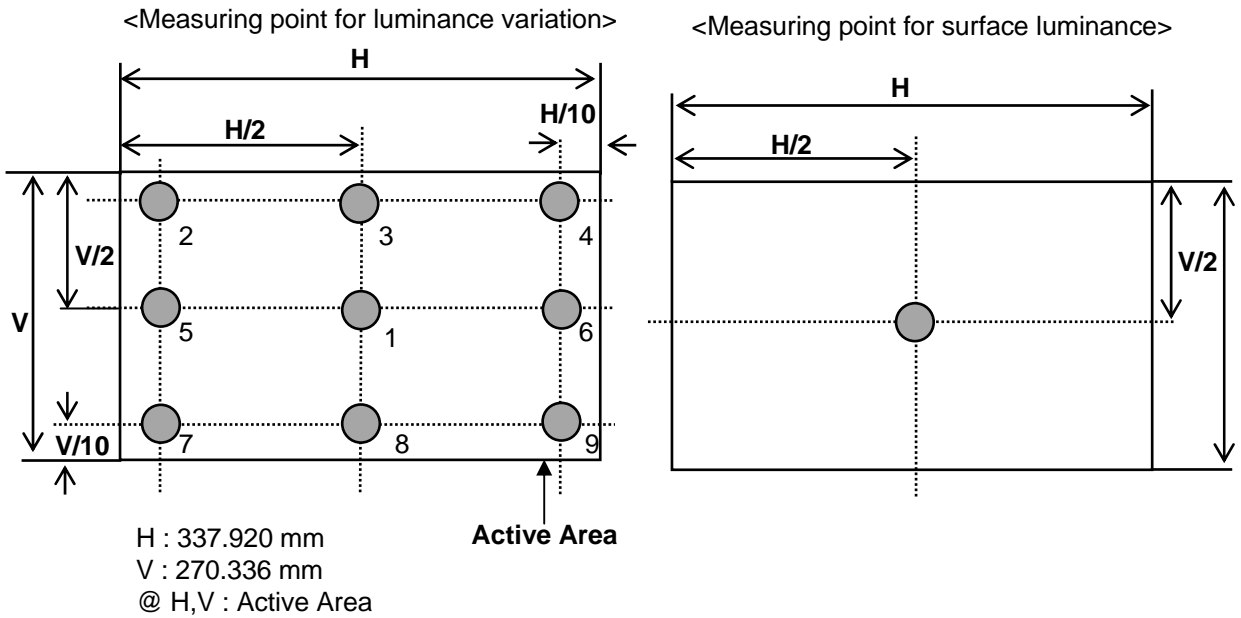

< Luminance Uniformity - angular – dependence (L_R & T_B)

TCO '03 Luminance uniformity – angular dependence, is the capacity of the VDU to present the same luminance level independently of the viewing direction. The angular-dependent luminance uniformity is calculated as the ratio of maximum luminance to minimum luminance in the specified measurement areas.

Test pattern : 80% white pattern

Test point : 2-point

Test distance : $D * 1.5 = 64.77$ cm

$$L_R = \left(\frac{L_{max.+30deg.}}{L_{min.+30deg.}} + \frac{L_{max.-30deg.}}{L_{min.-30deg.}} \right) / 2$$

$$T_B = \left(\frac{L_{max.+15deg.}}{L_{min.+15deg.}} \right)$$

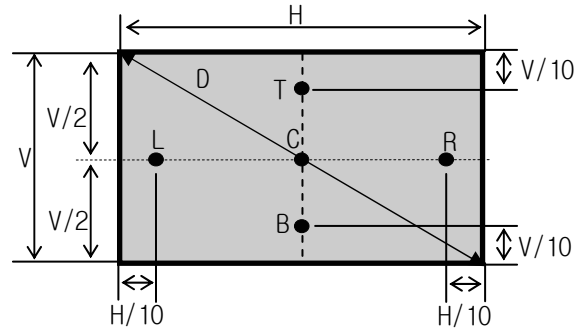

Product Specification

Figure 11. Response time

The response time is defined as the following Figure and shall be measured by switching the input signal for "black" and "white".

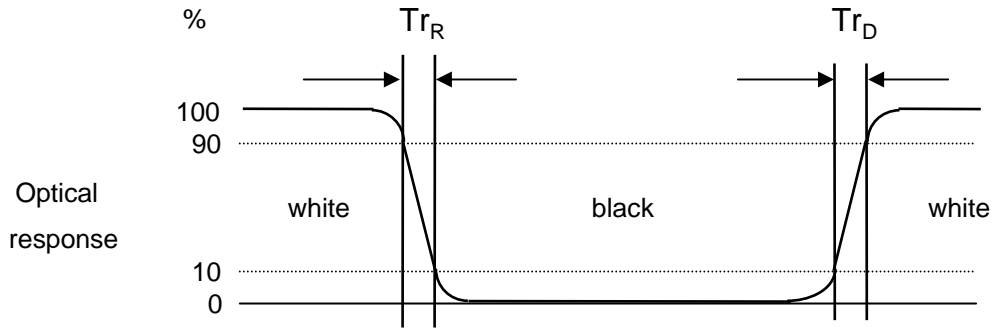
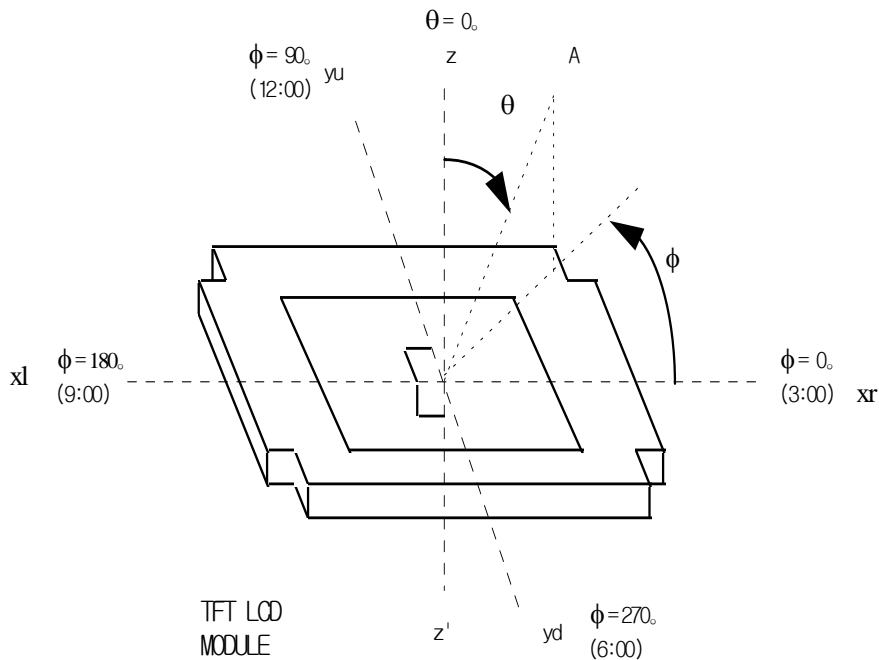

Figure 12. Viewing angle

<Dimension of viewing angle range>



Product Specification

Figure 13. Crosstalk

The equation of crosstalk : $(|L_{A[or C]2} - L_{A[or C]1}| / L_{A[or C]1}) \times 100(\%)$ [Vertical],
 $(|L_{B[or D]2} - L_{B[or D]1}| / L_{B[or D]1}) \times 100(\%)$ [Horizontal]

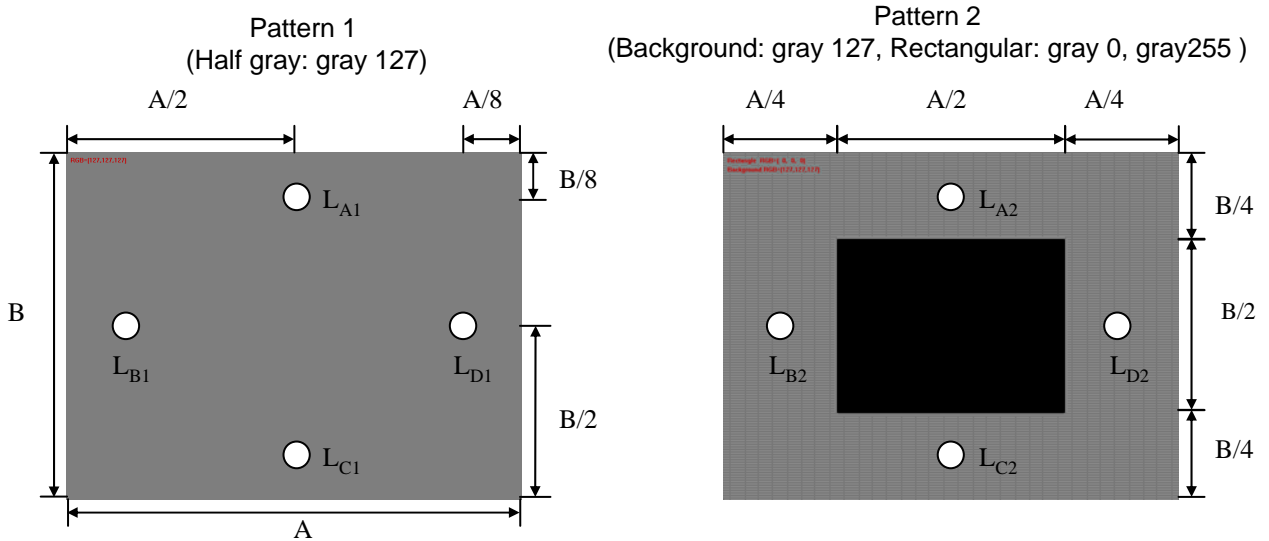

5. Mechanical Characteristics

Table 11. provides general mechanical characteristics for the model LM170E03-TLG3. Please refer to Figure 14,15 regarding the detailed mechanical drawing of the LCD.

Table 11. Mechanical characteristics

Outside dimensions	Horizontal	358.5mm
	Vertical	296.5mm
	Depth	16.0mm
Bezel area	Horizontal	341.6mm
	Vertical	274.0mm
Active display area	Horizontal	337.920mm
	Vertical	270.336mm
Weight(approximate)	1600g(Typ.),1680g(Max.)	
Surface Treatment	Hard coating(3H) Anti-glare treatment of the front polarizer	

Product Specification

Figure 14. Front view

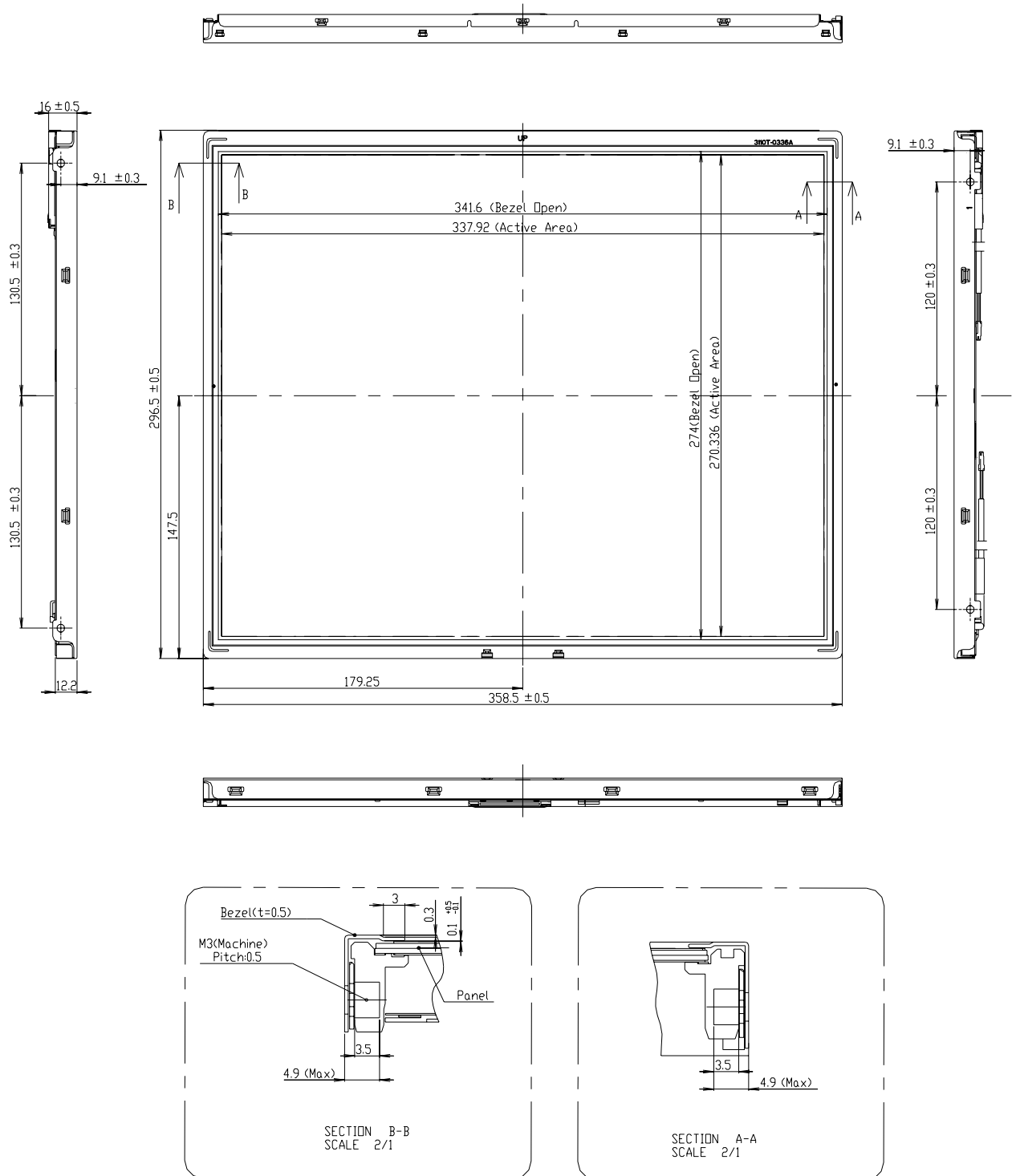

Product Specification

Figure 15. Rear view

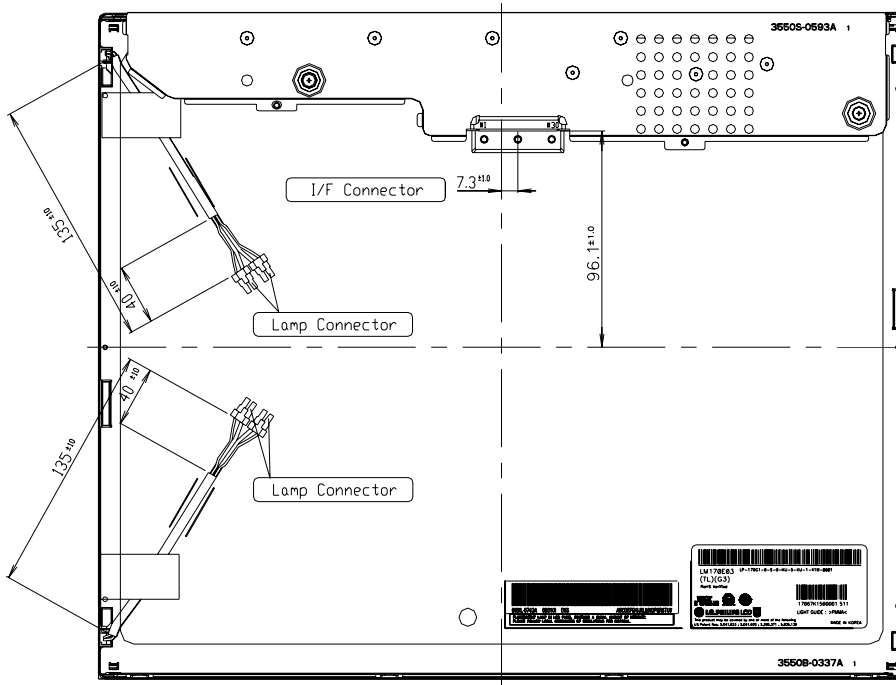

Notes

1. Backlight : 4 Cold Cathode Fluorescent Lamps.
2. I/F Connector Specification : UJU IS100-L30B-C23 or Equivalent
3. Torque of user hole : 2.5~3.5 kgf-cm
4. The CDF area is weak & sensitive, So, please don't press the CDF area.
5. Tilt and partial disposition tolerance of display area as following
 - (1) Y-Direction : |A-B| ≤ 1.0
 - (2) X-Direction : |C-D| ≤ 1.0

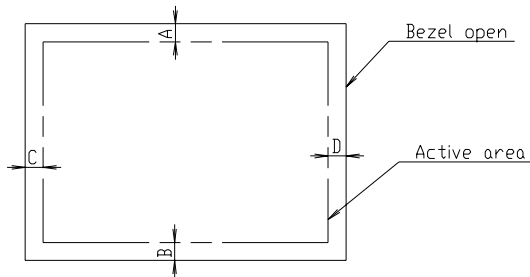

6. Lamp(CCFL) No. is marked at back light connector

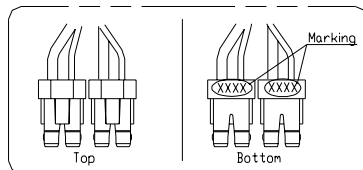

7. Do not wind conductive tape around the backlight wires
8. Gap between Bezel and Panel : Max 0.6mm
9. Unspecified tolerances to be ± 0.5mm

Product Specification

6. Reliability

Table 12. Environment test condition

No.	Test item	Conditions
1	High temperature storage test	Ta= 60°C 240h
2	Low temperature storage test	Ta= -20°C 240h
3	High temperature operation test	Ta= 50°C 50%RH 240h
4	Low temperature operation test	Ta= 0°C 240h
5	Vibration test (non-operating)	Wave form : random Vibration level : 1.0G RMS Bandwidth : 10-300Hz Duration : X,Y,Z, 30 min One time each direction
6	Shock test (non-operating)	Shock level : 120G Waveform : half sine wave, 2ms Direction : ±X, ±Y, ±Z One time each direction
7	Altitude storage / shipment	0 - 40,000 feet(12,192m)

{ Result evaluation criteria }

There should be no change which might affect the practical display function when the display quality test is conducted under normal operating condition.

Product Specification

7. International Standards

7-1. Safety

- a) UL 60950-1:2003, First Edition, Underwriters Laboratories, Inc., Standard for Safety of Information Technology Equipment.
- b) CAN/CSA C22.2, No. 60950-1-03 1st Ed. April 1, 2003, Canadian Standards Association, Standard for Safety of Information Technology Equipment.
- c) EN 60950-1:2001, First Edition, European Committee for Electrotechnical Standardization(CENELEC) European Standard for Safety of Information Technology Equipment.
- d) RoHS, Directive 2002/95/EC of the European Parliament and of the council of 27 January 2003

7-2. EMC

- a) ANSI C63.4 "Methods of Measurement of Radio-Noise Emissions from Low-Voltage Electrical and Electrical Equipment in the Range of 9kHz to 40GHz. "American National Standards Institute(ANSI), 1992
- b) C.I.S.P.R "Limits and Methods of Measurement of Radio Interface Characteristics of Information Technology Equipment." International Special Committee on Radio Interference.
- c) EN 55022 "Limits and Methods of Measurement of Radio Interface Characteristics of Information Technology Equipment." European Committee for Electrotechnical Standardization.(CENELEC), 1998 (Including A1: 2000)

Product Specification

8. Packing

8-1. Designation of Lot Mark

a) Lot Mark

A	B	C	D	E	F	G	H	I	J	K	L	M
---	---	---	---	---	---	---	---	---	---	---	---	---

A,B,C : SIZE(INCH)
E : MONTH

D : YEAR
F ~ M : SERIAL NO.

Note

1. YEAR

Year	2001	2002	2003	2004	2005	2006	2007	2008	2009	2010
Mark	1	2	3	4	5	6	7	8	9	0

2. MONTH

Month	Jan	Feb	Mar	Apr	May	Jun	Jul	Aug	Sep	Oct	Nov	Dec
Mark	1	2	3	4	5	6	7	8	9	A	B	C

b) Location of Lot Mark

Serial No. is printed on the label. The label is attached to the backside of the LCD module.
This is subject to change without prior notice.

8-2. Packing Form

- a) Package quantity in one box : 10pcs
- b) Box size : 420mm X 333mm X 431mm

Product Specification

9. Precautions

Please pay attention to the following when you use this TFT LCD module.

9-1. Mounting Precautions

- (1) You must mount a module using holes arranged in four corners or four sides.
- (2) You should consider the mounting structure so that uneven force(ex. twisted stress) is not applied to the module.
And the case on which a module is mounted should have sufficient strength so that external force is not transmitted directly to the module.
- (3) Please attach a transparent protective plate to the surface in order to protect the polarizer.
Transparent protective plate should have sufficient strength in order to the resist external force.
- (4) You should adopt radiation structure to satisfy the temperature specification.
- (5) Acetic acid type and chlorine type materials for the cover case are not describe because the former generates corrosive gas of attacking the polarizer at high temperature and the latter causes circuit break by electro-chemical reaction.
- (6) Do not touch, push or rub the exposed polarizers with glass, tweezers or anything harder than HB pencil lead. And please do not rub with dust clothes with chemical treatment.
Do not touch the surface of polarizer for bare hand or greasy cloth.(Some cosmetics are determined to the polarizer.)
- (7) When the surface becomes dusty, please wipe gently with absorbent cotton or other soft materials like chamois soaks with petroleum benzene. Normal-hexane is recommended for cleaning the adhesives used to attach front / rear polarizers. Do not use acetone, toluene and alcohol because they cause chemical damage to the polarizer.
- (8) Wipe off saliva or water drops as soon as possible. Their long time contact with polarizer causes deformations and color fading.
- (9) Do not open the case because inside circuits do not have sufficient strength.

9-2. Operating Precautions

- (1) The spike noise causes the mis-operation of circuits. It should be lower than following voltage :
 $V = \pm 200\text{mV}$ (Over and under shoot voltage)
- (2) Response time depends on the temperature.(In lower temperature, it becomes longer.)
- (3) Brightness depends on the temperature. (In lower temperature, it becomes lower.)
And in lower temperature, response time(required time that brightness is stable after turned on) becomes longer.
- (4) Be careful for condensation at sudden temperature change. Condensation makes damage to polarizer or electrical contacted parts. And after fading condensation, smear or spot will occur.
- (5) When fixed patterns are displayed for a long time, remnant image is likely to occur.
- (6) Module has high frequency circuits. Sufficient suppression to the electromagnetic interference shall be done by system manufacturers. Grounding and shielding methods may be important to minimized the interference.
- (7) Please do not give any mechanical and/or acoustical impact to LCM. Otherwise, LCM can not be operated its full characteristics perfectly.
- (8) A screw which is fastened up the steels should be a machine screw (if not, it causes metal foreign material and deal LCM a fatal blow)

Product Specification

9-3. Electrostatic Discharge Control

Since a module is composed of electronic circuits, it is not strong to electrostatic discharge. Make certain that treatment persons are connected to ground through wrist band etc. And don't touch interface pin directly.

9-4. Precautions for Strong Light Exposure

Strong light exposure causes degradation of polarizer and color filter.

9-5. Storage

When storing modules as spares for a long time, the following precautions are necessary.

- (1) Store them in a dark place. Do not expose the module to sunlight or fluorescent light. Keep the temperature between 5°C and 35°C at normal humidity.
- (2) The polarizer surface should not come in contact with any other object.
It is recommended that they be stored in the container in which they were shipped.

9-6. Handling Precautions for Protection Film

- (1) The protection film is attached to the bezel with a small masking tape.
When the protection film is peeled off, static electricity is generated between the film and polarizer. This should be peeled off slowly and carefully by people who are electrically grounded and with well ion-blown equipment or in such a condition, etc.
- (2) When the module with protection film attached is stored for a long time, sometimes there remains a very small amount of glue still on the Bezel after the protection film is peeled off.
- (3) You can remove the glue easily. When the glue remains on the Bezel or its vestige is recognized, please wipe them off with absorbent cotton waste or other soft material like chamois soaked with normal-hexane.



Product Specification

Warranty for Non-Inclusion of Hazardous Substances
in Products (ver.4.1)

Our company hereby warrants and guarantees that all of or part of products, including, but not limited to, the peripherals, accessories or (including your subsidiaries and affiliated company) directly or packages, manufactured and/ or delivered to your company indirectly by our company (including our subsidiaries or affiliated companies) are free from any of the substances listed in your company's Technology Standard or its subsequent revision, including the following articles,

- 1. Our company actually cooperates with environment-friendly policy pushed by your company and follows the total abolition schedule of Pb, Cd, Cr+6, Hg, PBB and PBDEs proposed by Hazardous substances management standard in your company
- 2. Our company don't excessively enclose to the noxious material including Cd, Pb in products and parts supporting to the department of DID in LG electronics. If the environmental accident is occurred by our company's mistake and insufficient improvement, acts on our company's responsibility
- 3. Our company ensure that all of information submitted to your company is not arbitrary estimation and is to the exact document based on reliable data.

By attached Data, Our company warrants this products comfirm to following requirements.(Check each applicable item)

Pb Free Soldering Pb Free RoHS Free TCO '03

Definition :

- Pb Free Soldering : Parts must meet DID's Heat resistance condition.
(Reflow Type:250°C,10sec, Flow Type : 260°C,10sec)
- Pb Free : Lead wire plating is Pb Free(Pb content < 1,000ppm) and Inner contact point and Body itself don't contain Pb(Pb content < 1,000ppm)
- RoHS Free : Part does not contain Pb,Cd,Cr+6,Hg,PBBs and PBDEs(Cd<100ppm,Others<1,000ppm) and supplier must submit evidences(ICP,AAS,UV-Vis,GC) certificated by authorised agency
- TCO '03 : Part meet TCO'03 and LG electronics requirement
(Cd<5ppm, Pb<50ppm, Hg<2ppm, Cr+6,PBBs,PBDEs<100)

Company name : *LG-Philips LCD*
Date : *Jan. 11. 2007*
Representative : *Mun-Cheol Jeong*
Signature : *[Handwritten Signature]*