

SPECIFICATION

For

APPROVAL

() Preliminary Specification
 () Final Specification »XGA TFT LCD

Title	15.1
-------	------

BUYER NAME	
MODEL NAME	

SUPPLIER	LG LCD Inc.
MODEL NAME	LM151X2-C2TH

SIGNATURE	DATE
/	_____
/	_____
/	_____

APPROVED BY	DATE
S.H.Kang /G.Manager	_____
REVIEWED BY	
I. H. Ahn /S.Engineer	_____
PREPARED BY	
T.K.Kark /S.Engineer	_____

Please return 1 copy for our confirmation with your signature and comments.

Product Engineering Dept.
LCD Division LG LCD Inc.

CONTENTS

NO.	ITEM	Page
-	COVER	1
-	CONTENTS	2
-	RECORD of REVISIONS	3
1.	GENERAL DESCRIPTIONS	4
2.	MAXIMUM RATINGS	5
3.	ELECTRICAL SPECIFICATIONS	5
4.	OPTICAL SPECIFICATIONS	6
5.	INTERFACE CONNECTIONS	10
6.	SIGNAL TIMING SPECIFICATIONS	11
7.	SIGNAL TIMING WAVEFORMS	12
8.	COLOR INPUT DATA REFERENCES	13
9.	POWER SEQUENCES	14
10.	MECHANICAL CHARACTERISTICS	15
11.	ENVIRONMENTAL SPECIFICATIONS	16
12.	DESIGNATION OF LOT MARK	17
13.	PACKING FORM	17
14.	PRECAUTIONS	18
15.	APPENDIX 1. OUTLINE DRAWINGS	19~20
16.	APPENDIX 2. PACKING ASSEMBLY DRAWINGS	21~22

Product Specification (Preliminary)

Record of Revisions

Revision Version	Date	DESCRIPTION
0.0	April 13, 1998	Preliminary
0.1	May 6, 1998	Preliminary, Update (Changed Interface Connections - Increased V_{DD} Lines, Fixed Interface Connector Model Name, Updated Outline Drawings)
0.2	June 16, 1998	Preliminary, Update (Updated Electrical Specifications, Optical Specifications, and Signal Timing Specifications)
0.3	June 22, 1998	Preliminary, Update (Updated Power Sequences, Updated Electrical Specifications - Back Light)
0.4	June 29, 1998	Preliminary, Update (Changed Environmental Specifications, Changed Outsize Dimensions - Thickness : Refer to Outline Drawings)
0.5	July 9, 1998	Preliminary, Update (Updated Optical Specifications)
0.6	July 21, 1998	Preliminary, Update (Updated Optical Specifications - Gamma Value)
0.7	September 17, 1998	Preliminary, Update (1. Updated Optical Specifications - Contrast Ratio, Viewing angle, Cross Talk 2. Updated Signal Timing Specifications - Main Clock, Hsync, Vsync 3. Updated Electrical Characteristics - Back Light Life Time)
1.0	October 14, 1998	Final, Update (1. Updated Outsize dimensions 2. Updated Electrical Specifications - Lamp Kick-Off Voltage)
1.1	November 16, 1998	Change the signal timing wave form
1.2	November 20, 1998	1. Change the set-up & hold duration 2. Add viewing angle at C/R ≥ 5
1.3	November 25, 1998	Change the model name (LM151X2→LM151X2-C2TH)

1. General Descriptions

The LG LCD model LM151X2 LCD is a Color Active Matrix Liquid Crystal Display with an integral Cold Cathode Fluorescent Tube (CCFT) back light system. The matrix employs a-Si Thin Film Transistor as the active element. It is a transmissive type display operating in the normally white mode. This TFT-LCD has a 15.1-inch diagonally measured active display area with XGA resolution (768 vertical by 1024 horizontal pixel array). Each pixel is divided into Red, Green and Blue sub-pixels or dots, which are arranged in vertical stripes. Gray scale or the brightness of the sub-pixel color is determined with a 6-bit gray scale signal for each dot, thus, presenting a palette of more than 262,144 colors.

LM151X2 has been designed to apply the CMOS logic level interface.

The LM151X2 LCD is intended to support applications where high brightness, wide viewing angle, high color saturation, and high color depth are very important. In combination with the vertical arrangement of the sub-pixels, the LM151X2 characteristics provide an excellent flat panel display for office automation products such as monitors.

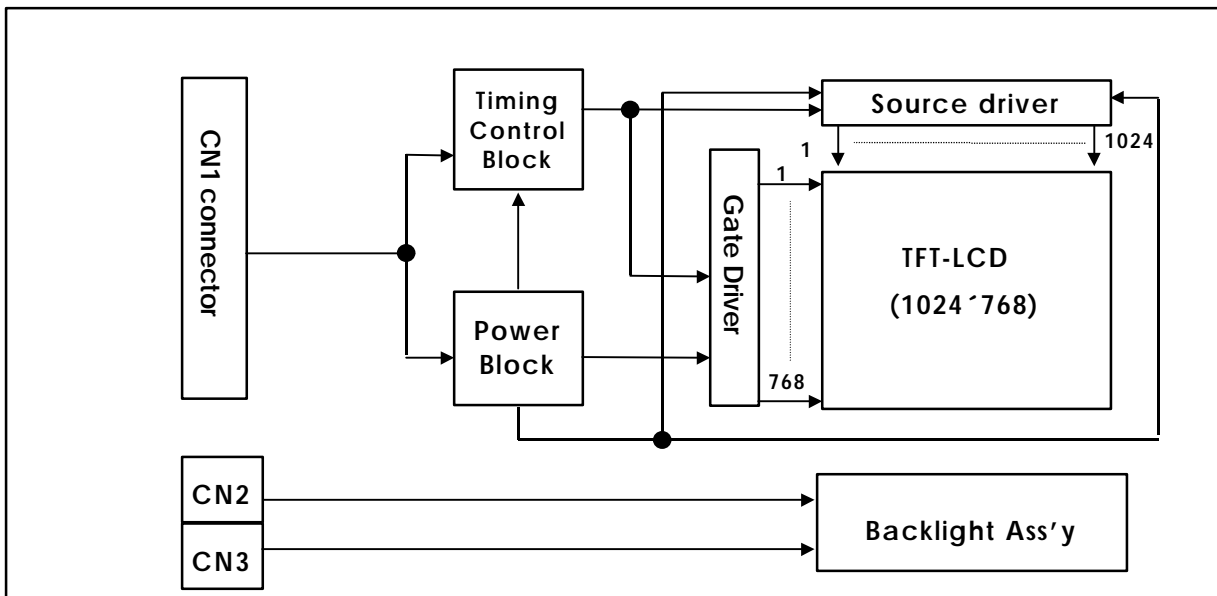

General Display Characteristics

The following are general features of the model LM151X2 LCD;

Active display area	15.1-inches (38cm) diagonal
Outside dimensions	352.6w x 265.0h x 18.5t(Typ.)mm (Without Inverter and User Connector)
Pixel pitch	0.30 mm \times 0.30 mm
Pixel format	1024 horiz. By 768 vert. pixels RGB vertical stripe arrangement
Color depth	6-bit, 262,144 colors
Display operating mode	transmissive mode, normally white
Surface treatments	hard coating(3H), anti-glare treatment of the front polarizer

Product Specification (Preliminary)
--

2. Maximum Ratings

The following are maximum values which, if exceeded, may cause faulty operation or damage to the unit.

Table 1 ABSOLUTE MAXIMUM RATINGS

Parameter	Symbol	Values		Units	Notes
		Min.	Max.		
Power Input Voltage	V_{DD}	0	+3.6	V_{DC}	at 25; 1
Lamp Current	I_{BL}	-	9.0	mArms	2
Operating Temperature	T_{OP}	0	+50	; 1	1
Storage Temperature	T_{ST}	-20	+60	; 1	

Note: 1. The Relative Humidity must not exceed 95% non-condensing at temperatures of 40; 1 or less. At temperatures greater than 40; 1 the wet bulb temperature must not exceed 39; 1
 2. Current shall be measured at ground line.

3. Electrical Specifications

The LM151X2 requires two power inputs. One input is employed to power the LCD electronics and to drive the voltages to drive the TFT array and liquid crystal. And the second input for the backlight CCFL, is typically generated by an inverter. The inverter is an external unit to the LCD.

Table 2 ELECTRICAL CHARACTERISTICS:

Parameter	Symbol	Values			Units	Notes
		Min.	Typ.	Max.		
MODULE :						
Power Supply Input Voltage	V_{DD}	3.15	3.3	3.45	V_{DC}	1
Power Supply Input Current	I_{DD}	-	500	800	mA	1, 2
Power Supply Kick Off Current	I_{DDI}	-	-	1,500	mA	7
Data Input High Voltage	V_{IH}	0.7; V_{DD}	-	$V_{DD} + 0.5$	V	1
Data Input Low Voltage	V_{IL}	-0.5	-	0.3; V_{DD}	V	1
BACK LIGHT :						
Back light Input voltage	V_{BL}	685	585	570	V_{RMS}	
Backlight Input Current	I_{BL}	3.0	8.0	9.0	mA	3
Lamp Kick-Off Voltage		-	-	880	V_{RMS}	At 25; 2; 1
		-	-	1145	V_{RMS}	At 0; 2; 1
		1290	-	-	V_{RMS}	4
		1660	-	-	V_{RMS}	At 25; 2; 1
					V_{RMS}	At 0; 2; 1
Operating Frequency	F_{BL}	30	50	80	KHz	5
Life time		25,000	40,000	-	hours	6

Notes: 1. All values shall be measured at the user connection.
 2. The input current shall be measured at V_{DD} of 3.3V at 25; 1 refresh rate of 60Hz, and clock frequency of 65MHz under 9 gray pattern.
 3. The backlight input current shall be measured at the ground cable and does not include loss of external inverter.
 4. Voltages at both ends of the lamp.
 5. Voltages at secondary side of transformer using the balancing capacitor, 22pF in inverter. These voltages can be changed with customer's own design of inverter.
 6. The life time is defined as the time at which brightness of lamp is 50% compare to that of initial value at the typical lamp current.
 7. Power supply kick off current means power supply input current at the moment of LCM power on. This current is higher than the current at the normal operating condition and it lasts for 50~100ms.

Product Specification (Preliminary)
4. Optical Specifications

Optical characteristics are determined after the unit has been 'ON' and stable for approximately 30 minutes in a dark environment at 25°C. The values specified are at an approximate distance 50cm from the LCD surface at a viewing angle of Φ and θ equal to 0° and aperture 1 degree. The test equipment is PhotoResearch Prichard SpectroRadiometer Model 1980B-SC or equivalent. The input signal voltage and timing specification are V_{DD} of 3.3V and VESA XGA @60Hz respectively. The input current of backlight is 8mA($F_{BL} = 50\text{KHz}$) at the ground terminals.

Table 2 OPTICAL CHARACTERISTICS

Parameter	Symbol	Values			Units	Notes
		Min.	Typ.	Max.		
Contrast Ratio	CR	150	200	-		1
Average Brightness, white	SB _{WH}	170	200	-	cd/m ²	2
Brightness Variation	SB _V	-	-	30	%	3
Response Time	Tr		50	80	msec	4
Rise Time	Tr _R	-	20	30		
Decay Time	Tr _D	-	30	50		
CIE Color Coordinates						
Red	x _R	0.600	0.630	0.660		
	y _R	0.310	0.340	0.370		
Green	x _G	0.270	0.300	0.330		
	y _G	0.570	0.600	0.630		
Blue	x _B	0.110	0.140	0.170		
	y _B	0.070	0.100	0.130		
White	x _W	0.290	0.320	0.350		
	y _W	0.310	0.340	0.370		
Viewing Angle by CR ≥ 10					degree, θ	5
x axis, right ($\theta = 0^\circ$)	θ	55	60	-		
x axis, left ($\theta = 180^\circ$)	θ	55	60	-		
y axis, up ($\theta = 90^\circ$)	θ	40	45	-		
y axis, down ($\theta = 270^\circ$)	θ	40	45	-		
Viewing Angle by CR ≥ 5						
x axis, right ($\theta = 0^\circ$)	θ	70	75			
x axis, left ($\theta = 180^\circ$)	θ	70	75			
y axis, up ($\theta = 90^\circ$)	θ	50	55			
y axis, down ($\theta = 270^\circ$)	θ	50	55			
Cross talk					%	
Horizontal		-	-	2.5		6
Vertical		-	-	2.5		
Gamma value		-	-	-		7

Product Specification (Preliminary)

Notes 1. Contrast Ratio (CR) is defined mathematically as:

$$\frac{\text{(Surface Brightness with all white pixels)}}{\text{(Surface Brightness with all black pixels)}}$$

Contrast ratio shall be measured at the center of the display (Location 1).

2. Average Brightness is the average of brightness value at location 1 to 5 with all pixels displaying white.

$$B(\text{AVE}) = \frac{B_1 + B_2 + B_3 + B_4 + B_5}{5}$$

3. The variation in surface brightness, SB_V is defined as :

$$\frac{\text{Maximum } (B_1, B_2, \dots, B_{13}) - \text{Minimum } (B_1, B_2, \dots, B_{13})}{\text{Average } (B_1, B_2, \dots, B_5)} \times 100(\%)$$

Where B1 to B13 are the brightness with all pixels displaying white at 13 locations.

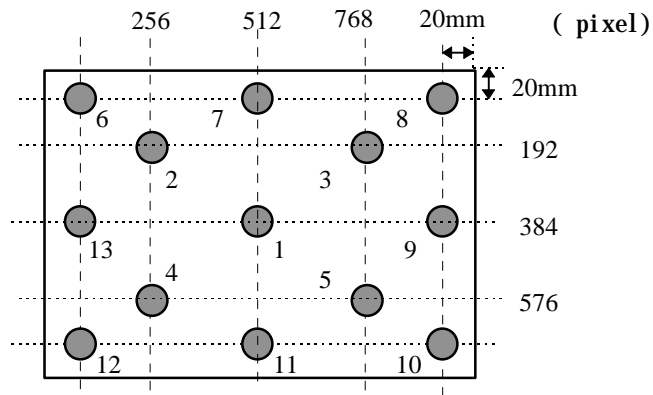

4. The response time is defined as the following figure and shall be measured by switching the input signal for "black" and "white".

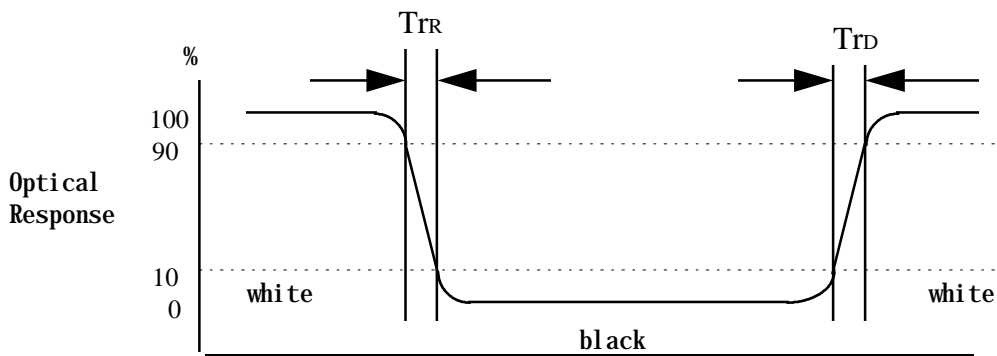

Product Specification (Preliminary)

5. Viewing angle is the angle at which the contrast ratio is greater than 10.

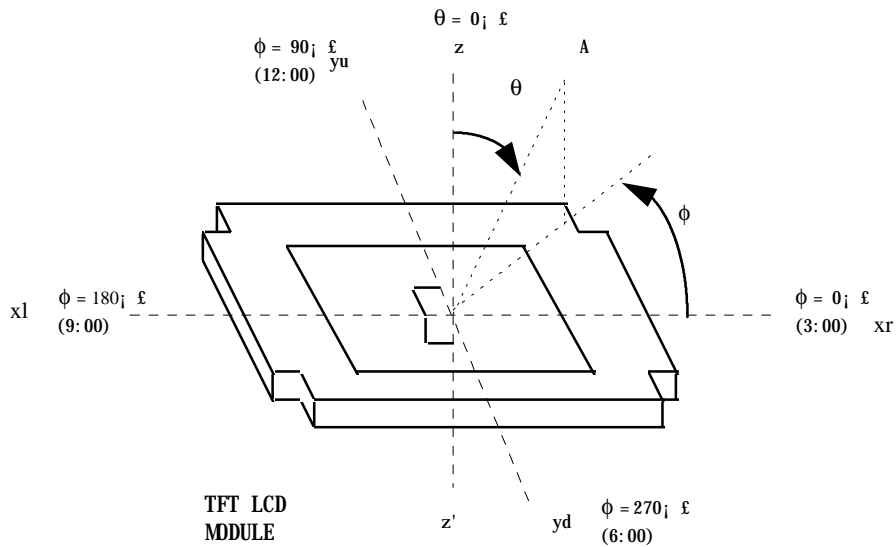

6. Cross talk shall be measured at two locations.

$$\text{Crosstalk Ratio} = 100 \times \frac{|\text{Brightness at pattern A} - \text{Brightness at pattern B}|}{\text{Brightness at pattern A}}$$

Pattern A
(Mid-gray : Gs(S)=31)

Pattern B
(Background:Gs(S)=31, Rectangular:Gs(S)=0 & 63)

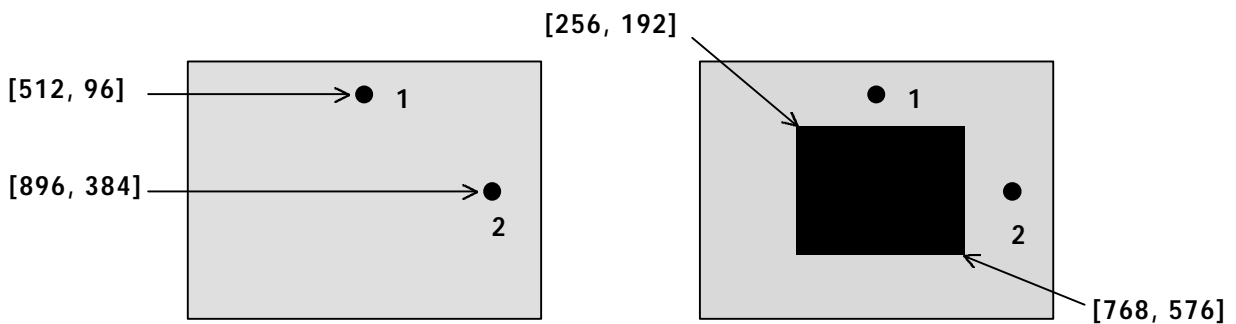

Vertical Crosstalk shall be measured at the location 1 and horizontal crosstalk shall be measured at the location 2.

Product Specification (Preliminary)
--

7. Gamma values shall be measured at the center location.

n	Gs(S)	Relative Brightness(%)		Remark
		min	max	
0	0	-	0.67	
1	7	-	1.8	
2	15	2.3	4.3	
3	23	5.4	9.4	
4	31	10.4	20.4	
5	39	22.8	34.8	
6	47	41.1	55.1	
7	55	66.7	82.7	
8	63	100	100	

Product Specification (Preliminary)
--

5. Interface Connections

This LCD employs three interface connections, a 41 pin connector is used for the module electronics and two connectors, a three pin connector, are used for the integral backlight system. The electronics interface connector is a model DF9B-41P-1V manufactured by Hirose. The pin configuration for the connector is shown in the table below.

Table 3 MODULE CONNECTOR PIN CONFIGURATION

Pin	Symbol	Description	Pin	Symbol	Description
1	GND	System Ground. Note 1	2	DCLK	Data Input Clock
3	GND	System Ground	4	H _{sync}	H _{sync} . Horizontal Sync Signal
5	V _{sync}	V _{sync} . Vertical Sync Signal	6	GND	System Ground
7	GND	System Ground	8	GND	System Ground
9	R0	Red data 0 (LSB)	10	R1	Red data 1
11	R2	Red data 2	12	GND	System Ground
13	R3	Red data 3	14	R4	Red data 4
15	R5	Red data 5 (MSB)	16	GND	System Ground
17	GND	System Ground	18	GND	System Ground
19	G0	Green data 0 (LSB)	20	G1	Green data 1
21	G2	Green data 2	22	GND	System Ground
23	G3	Green data 3	24	G4	Green data 4
25	G5	Green data 5 (MSB)	26	GND	System Ground
27	GND	System Ground	28	GND	System Ground
29	B0	Blue data 0 (LSB)	30	B1	Blue data 1
31	B2	Blue data 2	32	GND	System Ground
33	B3	Blue data 3	34	B4	Blue data 4
35	B5	Blue data 5 (MSB)	36	GND	System Ground
37	DE	Data Enable Signal	38	V _{DD}	Power Supply for LCD Module
39	V _{DD}	Power Supply for LCD Module	40	V _{DD}	Power Supply for LCD Module
41	V _{DD}	Power Supply for LCD Module			

- Notes:
1. All GND(ground) pins should be connected together and to V_{SS} which should also be connected to the LCD's metal frame.
 2. All V_{DD}(power input) pins should be connected together.

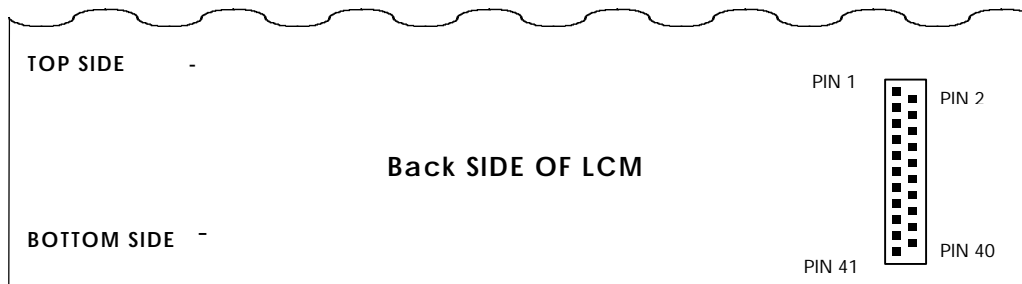

The backlight interface connector is a model BHR-03VS-1, manufactured by JST. The mating connector part number is SM02(8.0)B-BHS-1-TB or equivalent. The pin configuration for the connector is shown in the table below.

Table 4 BACKLIGHT CONNECTOR PIN CONFIGURATION

Pin	Symbol	Description	Notes
1	HV	Lamp power input	1
2	NC	No connect	
3	LV	Ground	2

- Notes:
1. The input power terminal is colored pink. Ground pin color is light pink.
 2. The backlight ground should be common with V_{SS}.

Product Specification (Preliminary)
6. Signal Timing Specifications

Parameter		Symbol	Value			Units	Notes
			Min.	Typ.	Max.		
Main Clock	Frequency	$f_{CLK}(=1/t_{CLK})$	63.0	65.0	67.0	MHz	
	High duration	t_{wCH}	$0.45 t_{CLK}$	$0.5 t_{CLK}$	$0.55 t_{CLK}$	ns	
	Low duration	t_{wCL}	$0.45 t_{CLK}$	$0.5 t_{CLK}$	$0.55 t_{CLK}$	ns	
	Rise Time	t_{rCLK}	-	-	8	ns	
	Fall Time	t_{fCLK}	-	-	8	ns	
Data (RGB data including sync)	Set-up duration	t_{SD}	3.5	-	-	ns	for f_{CLK}
	Hold duration	t_{HD}	3.5	-	-	ns	for f_{CLK} note 1
Hsync	Period	t_{HP}	16.5	20.7	-	§ Å	
	Pulse Width	t_{WH}	1056	1344	1368	clock	clock
Vsync	Period	t_{VP}	-	16.7	-	msec	
	Pulse Width	t_{WV}	777	806	840	lines	lines
Data Enable	Set-up duration	t_{SI}	5.0	-	-	ns	for f_{CLK}
	Hold duration	t_{HI}	5.0	-	-	ns	for f_{CLK}
	Horizontal Back Porch	t_{HBP}	8	160	-	clock	
	Horizontal Active		1024	1024	1024	clock	
	Horizontal Front porch	t_{HFP}	8	24	-	clock	
	Vertical Back Porch	t_{VBP}	5	29	-	lines	
	Vertical Active		768	768	768	lines	
	Vertical Front porch	t_{VFP}	1	3	-	lines	
Hsync- Clock phase difference		t_{HC}	$t_{CLK}-10$	-	t_{wCL}	ns	
Hsync-Vsync phase difference		t_{HV}	-	-	$t_{HP}-t_{WH}$	ns	

Notes: 1. All data input shall be latched at falling edge of data clock.

Product Specification (Preliminary)

7. Signal Timing Waveforms

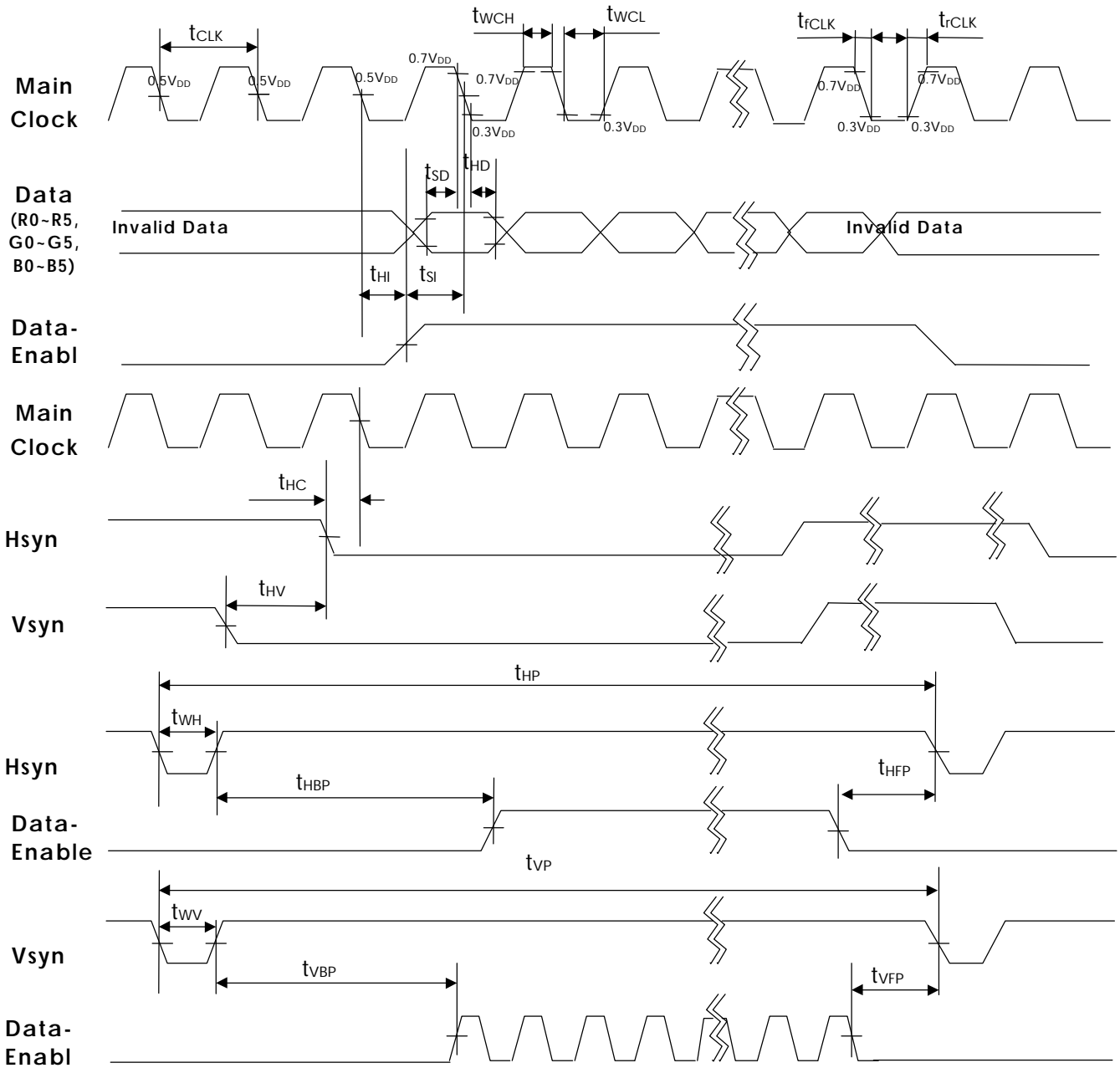

Product Specification (Preliminary)
--

8. Color Input Data References

The brightness of each primary color (red, green and blue) is based on the 6-bit gray scale data input for the color; the higher the binary input, the brighter the color. The table below provides a reference for color versus data input.

Table 5 COLOR DATA REFERENCE

Color		Input Color Data																	
		Red						Green						Blue					
		MSB			LSB			MSB			LSB			MSB			LSB		
		R5	R4	R3	R2	R1	R0	G5	G4	G3	G2	G1	G0	B5	B4	B3	B2	B1	B0
Basic Colors	Black	0	0	0	0	0	0	0	0	0	0	0	0	0	0	0	0	0	0
	Red(63)	1	1	1	1	1	1	0	0	0	0	0	0	0	0	0	0	0	0
	Green(63)	0	0	0	0	0	0	1	1	1	1	1	1	0	0	0	0	0	0
	Blue(63)	0	0	0	0	0	0	0	0	0	0	0	0	1	1	1	1	1	1
	Cyan	0	0	0	0	0	0	1	1	1	1	1	1	1	1	1	1	1	1
	Magenta	1	1	1	1	1	1	0	0	0	0	0	0	1	1	1	1	1	1
	Yellow	1	1	1	1	1	1	1	1	1	1	1	1	0	0	0	0	0	0
	White	1	1	1	1	1	1	1	1	1	1	1	1	1	1	1	1	1	1
Red	Red(0) Dark	0	0	0	0	0	0	0	0	0	0	0	0	0	0	0	0	0	0
	Red(1)	0	0	0	0	0	1	0	0	0	0	0	0	0	0	0	0	0	0
	Red(2)	0	0	0	0	1	0	0	0	0	0	0	0	0	0	0	0	0	0
	:	:	:	:	:	:	:	:	:	:	:	:	:	:	:	:	:	:	
	Red(61)	1	1	1	1	0	1	0	0	0	0	0	0	0	0	0	0	0	0
	Red(62)	1	1	1	1	1	0	0	0	0	0	0	0	0	0	0	0	0	0
	Red(63) Bright	1	1	1	1	1	1	0	0	0	0	0	0	0	0	0	0	0	0
Green	Green(0) Dark	0	0	0	0	0	0	0	0	0	0	0	0	0	0	0	0	0	0
	Green(1)	0	0	0	0	0	0	0	0	0	0	0	1	0	0	0	0	0	0
	Green(2)	0	0	0	0	0	0	0	0	0	0	1	0	0	0	0	0	0	0
	:	:	:	:	:	:	:	:	:	:	:	:	:	:	:	:	:	:	
	Green(61)	0	0	0	0	0	0	1	1	1	1	0	1	0	0	0	0	0	0
	Green(62)	0	0	0	0	0	0	1	1	1	1	1	0	0	0	0	0	0	0
	Green(63) Bright	0	0	0	0	0	0	1	1	1	1	1	1	0	0	0	0	0	0
Blue	Blue(0) Dark	0	0	0	0	0	0	0	0	0	0	0	0	0	0	0	0	0	0
	Blue(1)	0	0	0	0	0	0	0	0	0	0	0	0	0	0	0	0	0	1
	Blue(2)	0	0	0	0	0	0	0	0	0	0	0	0	0	0	0	0	1	0
	:	:	:	:	:	:	:	:	:	:	:	:	:	:	:	:	:	:	
	Blue(61)	0	0	0	0	0	0	0	0	0	0	0	0	1	1	1	1	0	1
	Blue(62)	0	0	0	0	0	0	0	0	0	0	0	0	1	1	1	1	1	0
	Blue(63) Bright	0	0	0	0	0	0	0	0	0	0	0	0	1	1	1	1	1	1

Product Specification (Preliminary)

9. Power Sequences

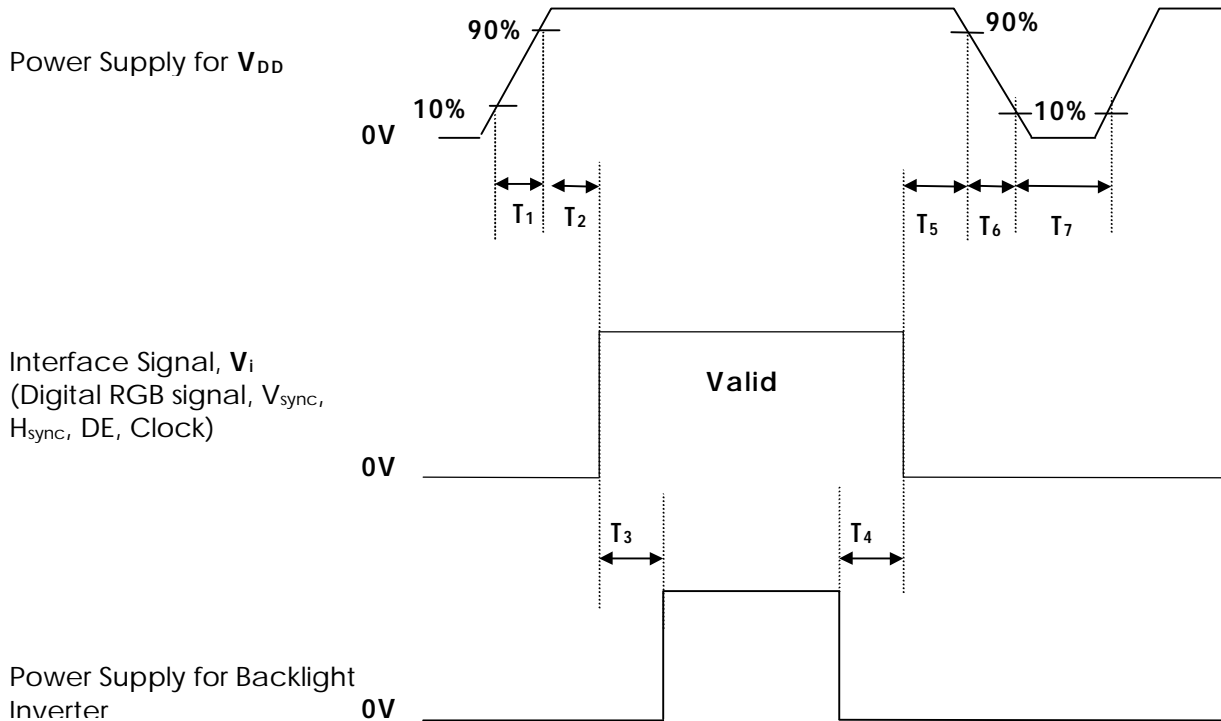

- T_1, T_6 : 10 ns ~ 20 ms.
- T_2, T_5 : 50 ms (max.)
- T_3, T_4 : 300 ms (min.)
- T_7 : 500ms (min.)

Notes: 1. Please avoid floating state of interface signal at invalid period.
 2. When the interface signal is invalid, be sure to pull down the power supply for LCD V_{DD} to 0V.
 3. BackLight inverter power must be turn on after power supply for LCD and interface signal are valid.

Product Specification (Preliminary)
--

10. Mechanical Characteristics

The chart below provides general mechanical characteristics for the model LM151X2 LCD. Please refer to appendix 2 regarding the detailed mechanical drawing of the LCD module.

Parameter	Value	Symbol	Notes
Outside dimension Width Height Thickness	352.6 (typ) 265.0 (typ) 18.5 (typ)	mm	
Bezel area Width Height	311.2 234.4	mm	
Active area Width Height	307.2 230.4	mm	
Weight	1500(typ) 1600 (max)	gram	
Front surface of LCD	Hard coating 3H. Anti-glare treatment of the front polarizer	-	

Product Specification (Preliminary)
--

11. Environmental Specifications

No	Test ITEM		Conditions
1	Temperature	Operating Non-operating	0; É- 50; É -20; É- 60; É
2	Humidity	Operating Non-operating	20% ~ 80% RH (non-condensing) 5% ~ 95% RH (38.7; Émaximum wet bulb temperature)
3	Altitude		Operating : 12,000ft Storage : 40,000ft
4	Vibration test (non-operating)		Waveform : Random Vibration level : 1.0G RMS Bandwidth : 10~200Hz Duration : X, Y, Z, 20 min one time each direction
5	Shock test (non-operating)		Shock level : 100G Waveform: half sine wave, 2ms Direction : ±X, ±Y, ±Z one time each direction

Product Specification (Preliminary)
--

12. Designation of Lot Mark

a) Lot Mark

A	B	C	D	E	F	G	H	I	J	K	L
---	---	---	---	---	---	---	---	---	---	---	---

A, B : DIVISION CODE
 C, D, E : MODEL CODE
 F : YEAR
 G : MONTH
 H, I, J, K, L : SERIAL NO.

Note : 1. YEAR

YEAR	89	90	91	92	93	94	95	96	97	98	99
Mark	9	0	1	2	3	4	5	6	7	8	9

2. MONTH

MONTH	Jan.	Feb.	Mar.	Apr.	May	Jun.	Jun.	Aug.	Sep.	Oct.	Nov.	Dec.
Mark	1	2	3	4	5	6	7	8	9	0	N	D

b) Location of Lot Mark

Serial NO. Is printed on the label. The label is attached to the backside of the LCD module.
 This is subject to change without prior notice.

13. Packing Form

a) Package quantity in one box : 8 pcs

b) Box Size : 587mm_i 408mm_i 378mm

Note : 1. Please, refer to appendix 3 regarding the detailed packing assembly drawing.

14. PRECAUTIONS

Please pay attention to the followings when you use this TFT-LCD module with Back-light unit.

- 1) You must mount Module using mounting holes arranged in 4 corners.
- 2) Be sure to turn off the power when connecting or disconnecting the circuit.
- 3) Note that the polarizers are easily damaged. Pay attention not to scratch or press this surface with any hard object.
- 4) When the LCD surface become dirty, please wipe it off with a soft material. (ie. cotton ball)
- 5) Protect the module from the ESD as it may damage the electronic circuit (C-MOS).
Make certain that treatment person's body are grounded through wrist bend.
- 6) Do not disassemble the module and be careful not to incur a mechanical shock that might occur during installation. It may cause permanent damage.
- 7) Do not leave the module in high temperatures, particularly in areas of high humidity for a long time.
- 8) The module not be expose to the direct sunlight.
- 9) Avoid contact with water as it may a short circuit within the module.
- 10) Do not apply invalid signal, especially very high frequency data clock and H_{sync} . Invalid signal causes improper shutdown of DC/DC converter in LCM or permanent damage to LCD module.
(If DC/DC converter in LCM is in shutdown state, LCM shows only white screen. Then please turn off and on once LCM power.)
- 11) If the LCM displays the same pattern continuously for a long period of time, it can be the image sticking to the screen.

Product Specification (Preliminary)

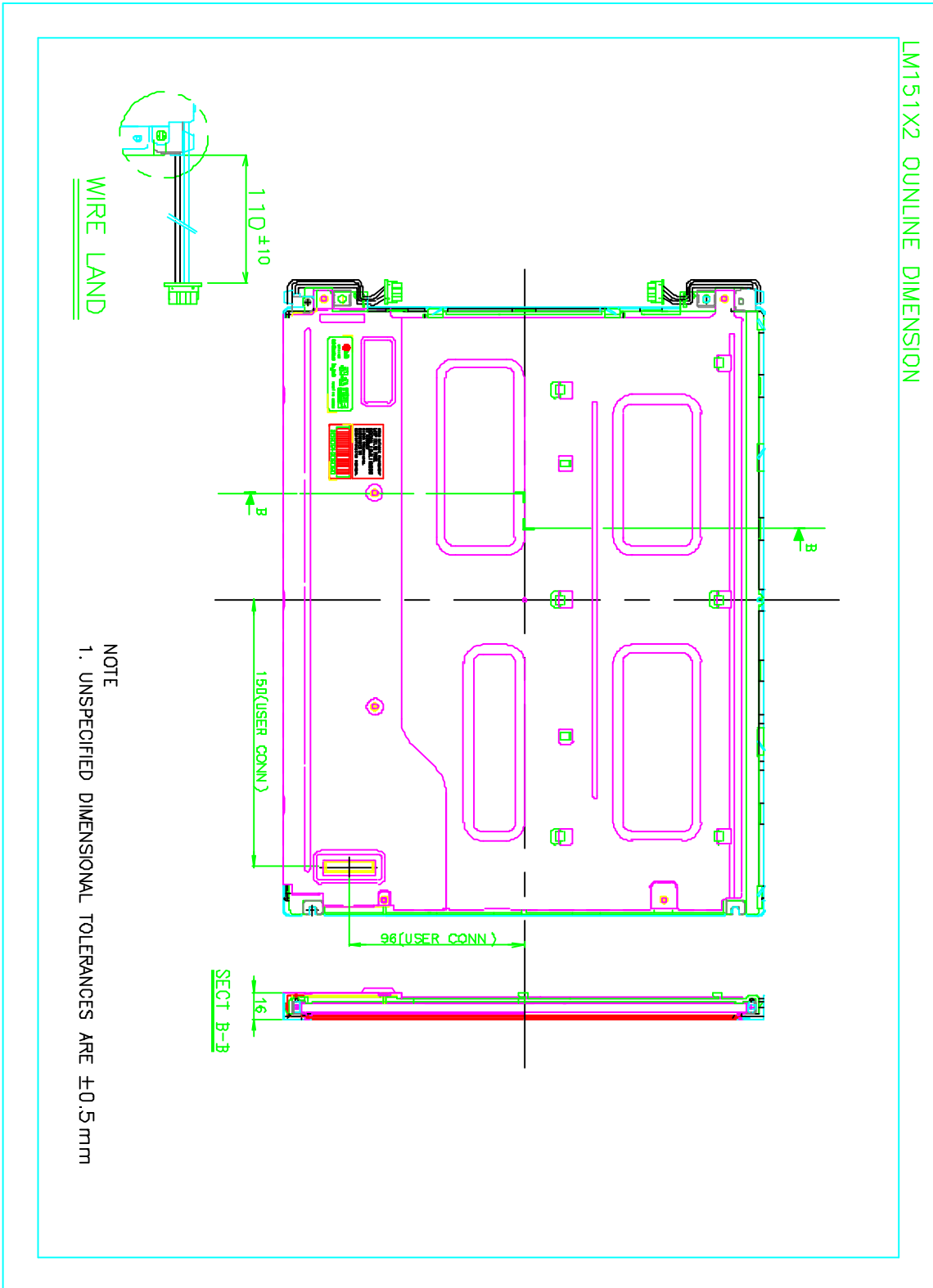

Product Specification (Preliminary)

16. APPENDIX 2 : Packing Assembly Drawings

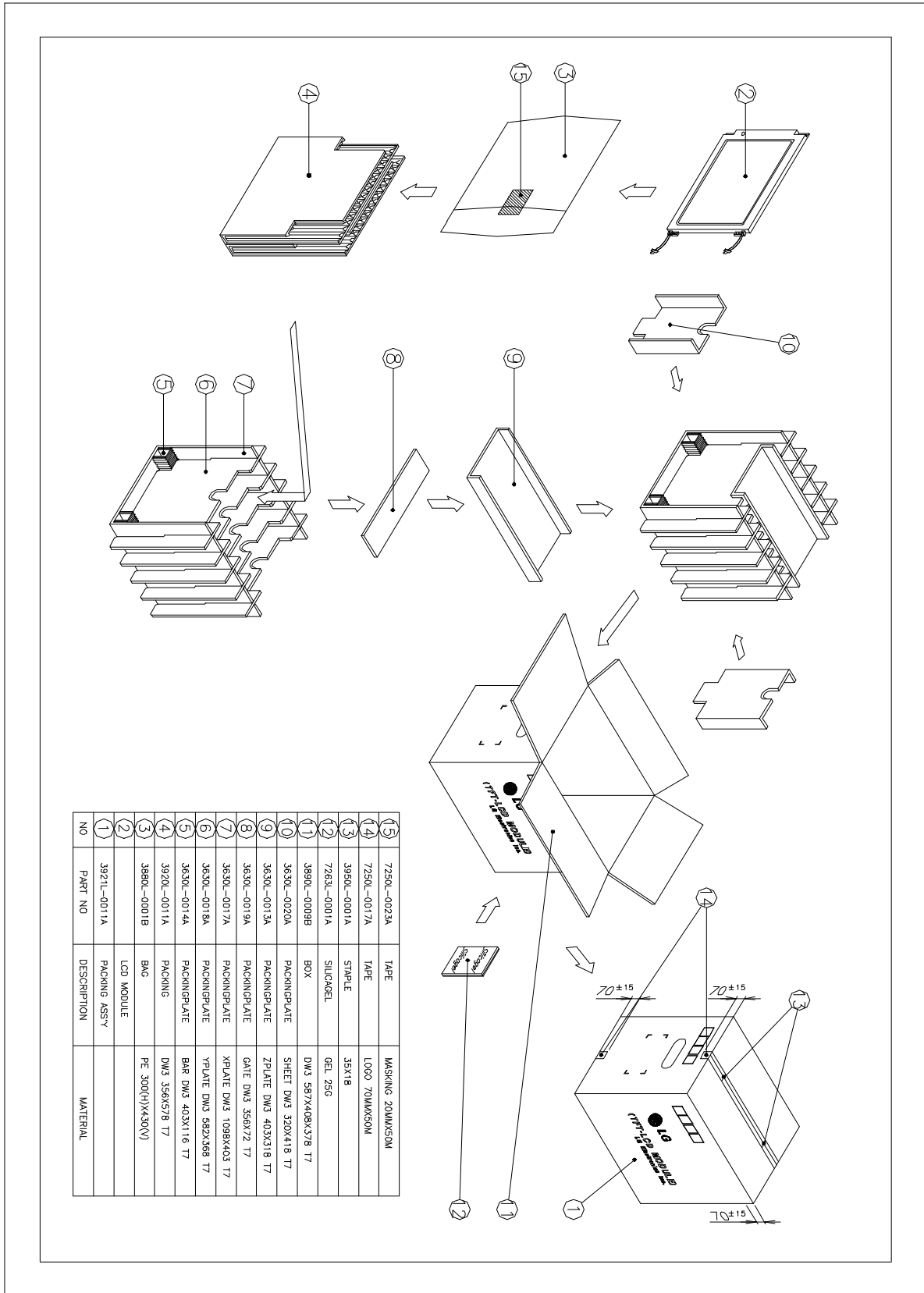

Product Specification (Preliminary)

