

PREPARED BY: DATE	<h1>SHARP</h1> <p>LIQUID CRYSTAL DISPLAY GROUP SHARP CORPORATION</p> <h2>SPECIFICATION</h2>	SPEC No. LC00307
APPROVED BY: DATE		FILE No.
		ISSU MAR.1.2000
		PAGE 28 Pages
	REPRESENTATIVE DIVISION	
		ENGINEERING DEPARTMENT 1 DUTY LCD DEVELOPMENT CENTER DUTY LIQUID CRYSTAL DISPLAY GROUP

DEVICE SPECIFICATION for
Passive Matrix Color LCD Module
(800×600 dots)

Model No.
LM100SS1T522

CUSTOMER'S APPROVAL

DATE _____

BY _____

PRESENTED

BY

M.Ise

DIVISION GENERAL MANAGER
DUTY LCD DEVELOPMENT CENTER
DUTY LIQUID CRYSTAL DISPLAY GROUP
SHARP CORPORATION

○Precautions

1) Industrial(Mechanical) design of the product in which this LCD module will be incorporated must be made so that the viewing angle characteristics of the LCD may be optimized.

This module's viewing angle is illustrated in Fig.1.

$\theta y \text{ MIN.} < \text{viewing angle} < \theta y \text{ MAX.}$

(For the specific values of $\theta y \text{ MIN.}$, and $\theta y \text{ MAX.}$, refer to the table)

Please consider the optimum viewing conditions according to the purpose when installing the module.

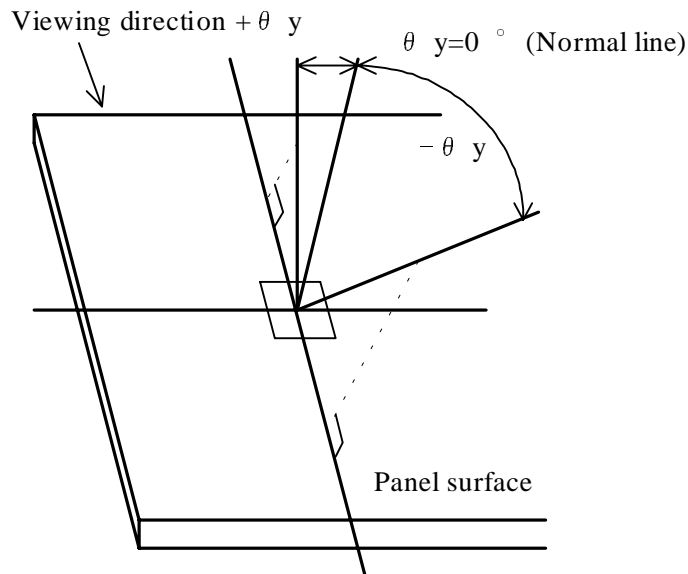

Fig.1 Definition of viewing angle

2) This module should be installed using mounting holes of metal bezel.

When installing the module, pay attention and handle carefully not to allow any undue stress such as twist or bend.

3) Since the front polarizer is easily damaged. Please pay attention not to scratch on its face.

It is recommended to use a transparent acrylic resin board or other type of protective panel on the surface of the LCD module to protect the polarizer, LCD panel, etc..

4) If the surface of the LCD panel is required to be cleaned, wipe it swiftly with cotton or other soft cloth. If it is not still clear completely, blow on and wipe it.

5) Water droplets, etc. must be wiped off immediately since they may cause color changes, staining, etc., if it remained for a long time.

6) Since LCD is made of glass substrate, dropping the module or banging it against hard objects may cause cracking or fragmentation.

7) Since CMOS LSIs are equipped in this module, following countermeasures must be taken to avoid electrostatics charge.

1. Operator

Electrostatic shielding clothes shall be had because it is feared that the static electricity is electrified to human body in case that operator have a insulating garment.

2. Equipment

There is a possibility that the static electricity is charged to equipment which have a function of peeling or mechanism of friction(EX: Conveyer, soldering iron, working table), so the countermeasure(electrostatic earth: $1 \times 10^8 \Omega$) should be made.

3. Floor

Floor is a important part to leak static electricity which is generated from human body or equipment.

There is a possibility that the static electricity is charged to them without leakage in case of insulating floor, so the countermeasure(electrostatic earth: $1 \times 10^8 \Omega$) should be made.

4. Humidity

Humidity of working room may lower electrostatics generating material's resistance and have something to prevent electrifying. So, humidity should be kept over 50% because humidity less than 50 % may increase material's electrostatic earth resistance and it become easy to electrify.

5. Transportation/storage

The measure should be made for storage materials because there is a possibility that the static electricity, which electrify to human body or storage materials like container by friction or peeling, cause the dielectric charge.

6. Others

The laminator is attached on the surface of LCD module to prevent from scratches, fouling and dust.

It should be peeled off unhurriedly with using static eliminator.

And also, static eliminator should be installed to prevent LCD module from electrifying at assembling line.

8) Don't use any materials which emit gas from epoxy resin(amines' hardener) and silicon adhesive agent(dealcohol or deoxym) to prevent change polarizer color owing to gas.

9) Since leakage current, which may be caused by routing of CCFT cables, etc., may affect the brightness of display, the inverter has to be designed taking the leakage current into consideration. Thorough evaluation of the LCD module/inverter built into its host equipment shall be conducted, therefore, to ensure the specified brightness.

10) Avoid to expose the module to the direct sun-light, strong ultraviolet light, etc. for a long time.

11) If stored at temperatures under specified storage temperature, the LC may freeze and be deteriorated.

If storage temperature exceed the specified rating, the molecular orientation of the LC may change to that of a liquid, and they may not revert to their original state. Therefore, the module should be always stored at normal room temperature.

12) Disassembling the LCD module can cause permanent damage and should be strictly avoided.

13) Matters to be attended to connectors(I/F connector on LCD module and mating connector insersion/extraction)

Please pay attention to the following contents because I/F connector sometimes be fractured easily due to the stress on the insersion and extraction of connectors and the stress to the case of I/F connecer.

-An mating interface connector shall be inserted and pulled out slowly in parallel with the LCD module side connector as mentioned in the below figure.

-An mating interface connector shall not be inserted and pulled out under the condition that it is twisted.

-Any stress shall not be applied to the case of I/F connector of the LCD module

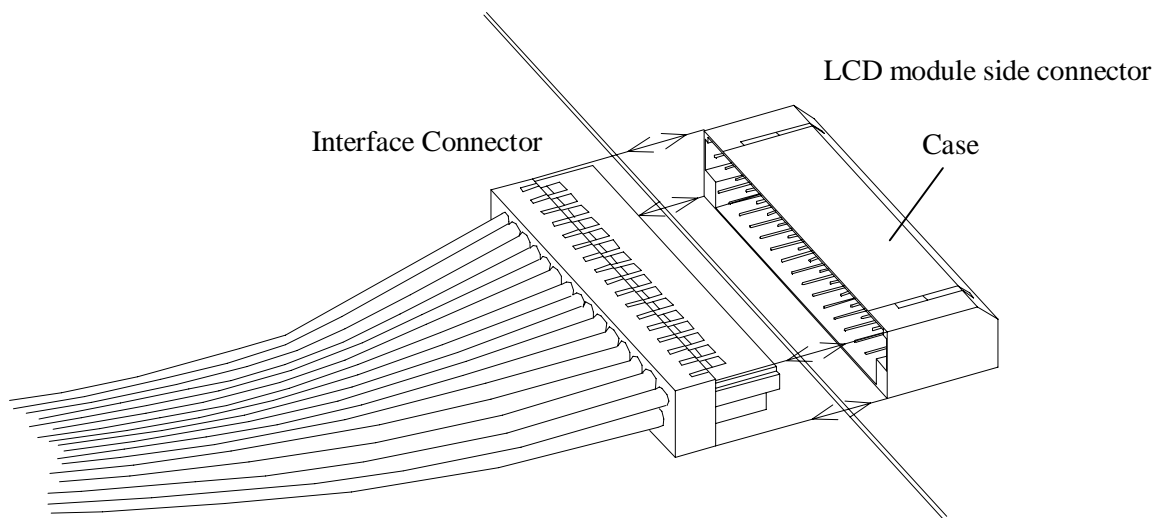

- 14) This specification describes display quality in case of no gray scale. Since display quality can be affected by gray scale methods, display quality shall be carefully evaluated for the usability of LCD module in case gray scale is displayed on the LCD module.
- 15) The module should be driven according to the specified ratings to avoid permanent damage.
DC voltage drive leads to rapid deterioration of LC, so ensure that the drive is alternating waveform by continuous application of the signal M. Especially the power ON/OFF sequence shown on Page 26 should be kept to avoid latch-up of drive LSI and application of DC voltage to LCD panel
- 16) It is a characteristic of LCD to maintain the displaying pattern when the pattern is applied for a long time .(Image retention)
To prevent image retention, please do not apply the fixed pattern for along time by pre-installing such programs at your side.
- 17) This phenomena (image retention) is not deterioration of LCD. If it happens, you can remove it by applying different patterns.
- 18) CCFT backlight should be kept OFF during VDD is "L" level.

WARNING

Don't use any materials which emit following gas from epoxy resin (amines' hardener) and silicone adhesive agent (dealcohol or deoxym) to prevent change polarizer color owing to gas.

	Page
○Contents	
1.Application.....	6
2.Construction and Outline.....	6
3.Mechanical Specification	7
4.Absolute Maximum Ratings.....	7
4-1.Electrical absolute maximum ratings	7
4-2.Environment Conditions	8
5.Electrical Specifications	9
5-1.Electrical characteristics	9
5-2.Interface signals	11
6. Module Driving Method.....	17
6-1. Circuit configuration.....	17
6-2. Display face configuration	17
6-3. Input data and control signal	17
7.Optical Characteristics	19
8.Characteristics of Backlight.....	24
9.ON/OFF voltage sequence condition.....	26
10.Applicable inspection standard.....	27
11.Lot Number	27
12.Outline dimensions.....	28

1.Application

This data sheet is to introduce the specification of LM100SS1T522, passive Matrix type Color LCD module.

2.Construction and Outline

Construction: 800×600 dots color display module consisting of an LCD panel, PWB(printed wiring board) with electric components mounted onto, TCP(tape carrier package) to connect the LCD panel and PWB electrically, and plastic chassis with CCFT back light and bezel to fix them mechanically.

Signal ground(Vss) is connected with the metal bezel.

DC/DC converter is built in.

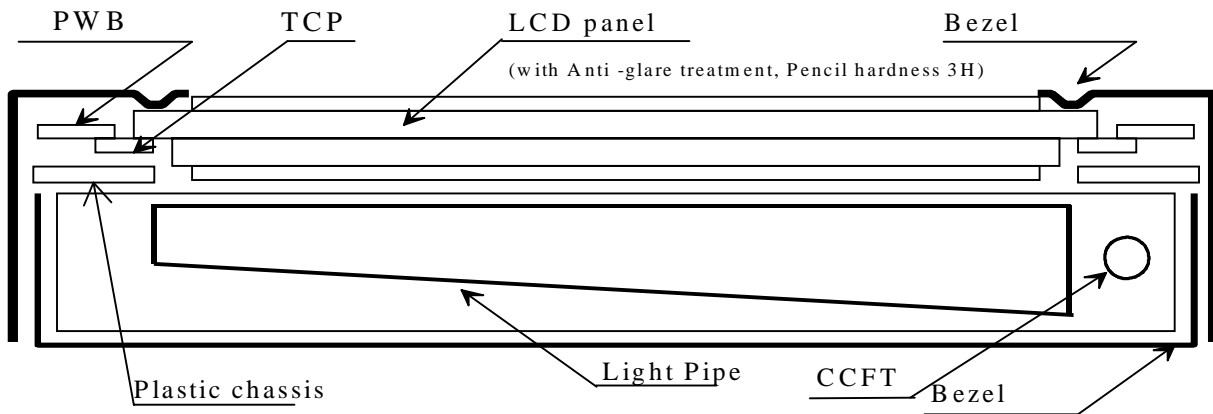

Outline :See Fig. 14

Connection :See Fig. 14 and Table 6

3.Mechanical Specification

Table1

Parameter	Specifications	Unit
Outline dimensions	$236.8 \pm 0.5(W) \times 172.5 \pm 0.5(H) \times 6.8\text{MAX}(D)$	mm
Effective viewing area	$207(W) \times 156(H)$	mm
Display format	$800(W) \times 600(H)$	mm
Dot size	$0.065 \times \text{RGB}(W) \times 0.235(H)$	-
Dot spacing	0.02	mm
*1 Base color	Normally black *2	-
Weight	Approx. 340	g

*1 Due to the characteristics of the LC material, the colors vary with environmental temperature.

*2 Negative-type display

Display data“H” : ON → transmission

Display data“L” : OFF → light isolation

4.Absolute Maximum Ratings

4-1.Electrical absolute maximum ratings

Table 2

Parameter	Symbol	MIN.	MAX.	Unit	Remark
Supply voltage(Logic)	$V_{DD}-V_{SS}$	0	4.5	V	Ta=25 °C
Input voltage	V_{IN}	-0.3	$V_{DD}+0.3$	V	Ta=25 °C
Vcon voltage	Vcon	0	V_{DD}	V	Ta=25 °C

4-2.Environment Conditions

Table 3

Item	Tstg		Topr		Remark
	MIN.	MAX.	MIN.	MAX.	
Ambient temperature	-25 °C	+60 °C	0 °C	+40°C	Note 4)
Humidity	Note 1)		Note 1)		No condensation
Vibration	Note 2)		Note 2)		3 directions(X/Y/Z)
Shock	Note 3)		Note 3)		6 directions(± X± Y± Z)

Note 1) $T_a \leq 40 \text{ °C}$95 % RH Max.

$T_a > 40 \text{ °C}$Absolute humidity shall be less than $T_a=40 \text{ °C}/95 \text{ % RH}$.

Note 2)

Table 4

Frequency	10 Hz~57 Hz	57 Hz~500 Hz
Vibration level	-	9.8 m/s ²
Vibration width	0.075 mm	-
Interval	10 Hz~500 Hz~10 Hz/11.0 min	

2 hours for each direction of X/Y/Z (6 hours as total)

Note 3) Accerelation : 490 m/s²

Pulse width : 11 ms

3 times for each directions of ± X/± Y/± Z

Note 4) Care should be taken so that the LCD module may not be subjected to the temperature out of this specification.

5. Electrical Specifications

5-1. Electrical characteristics

Table 5 Ta=25 °C VDD= 3.3± 0.3V 1/tFRM=120 Hz (Note 3)

Parameter	Symbol	Conditions	Min.	Typ.	Max.	Unit	
Supply voltage (Logic)	V _{DD} -V _{SS}	Ta = 0~40 °C (Note 1)	3.0	3.3	3.6	V	
Contrast adjust voltage (Note 4)	V _{con} -V _{SS}	Ta =0~40°C	0.8	(1.95)	2.8	V	
Input signal voltage	V _{IN}	“H” level	Ta = 0~ 40 °C	0.8V _{DD}	-	V _{DD}	V
		“L” level		0	-	0.2V _{DD}	V
Supply current	I _{DD} (TYP.)	Ta =25 °C (Note 1,2)	-	(205)	(295)	mA	
Rush current (Logic)	I _{rush}	Ta =25 °C (Note 1)	(1.0 A(pk)×30 ms)				
Ripple current (Logic)	I _{rip}	Ta =25 °C (Note 1)	(0.5 A(pk)×40 μs)				
Power consumption	Pd(TYP.)	Note 2)	-	(680)	(975)	mW	

Note 1) Under the following conditions.;

- ① Immediately after the rise of V_{DD} . : (1.0 A(pk)×30 ms)
- ② Under the situation that DISP signal is on and kept steady : (0.5 A(pk)×40 μs)

Note 2) Frame Frequency = 120 Hz , Vcon - Vss = 1.95 V

Display pattern = Checker pattern

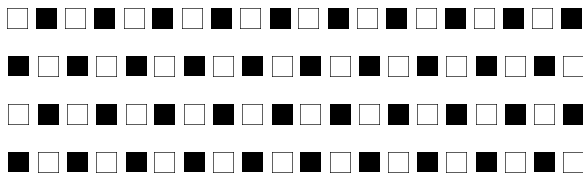

Note 3) The shadowing is adjusted on this module to the following conditions. When LCD module is operated in the other conditions, that should be informed in advance because display quality may be deteriorated in this case.

Frame frequency :120 Hz

Note 4) Contrast adjust voltage “Vcon-Vss” is transformed into the LCD driving voltage “V_{LCD}” by following circuit built in the LCD module.

LCD driving voltage “V_{LCD}” is adjusted automatically according to the change of ambient temperature range by the temperature compensation circuit.

Temperature compensation circuit built in LCD module have been set obtain the optimum contrast under following driving conditions.;

Take care that voltage for optimum contrast is changed under the different condition.

Frame frequency : 120 Hz, Duty ratio : 1/300(an odd number frame), Ta = 25 °C
1/328(an even number frame)

※The above is the condition of the module setting, not the electrical characteristics.

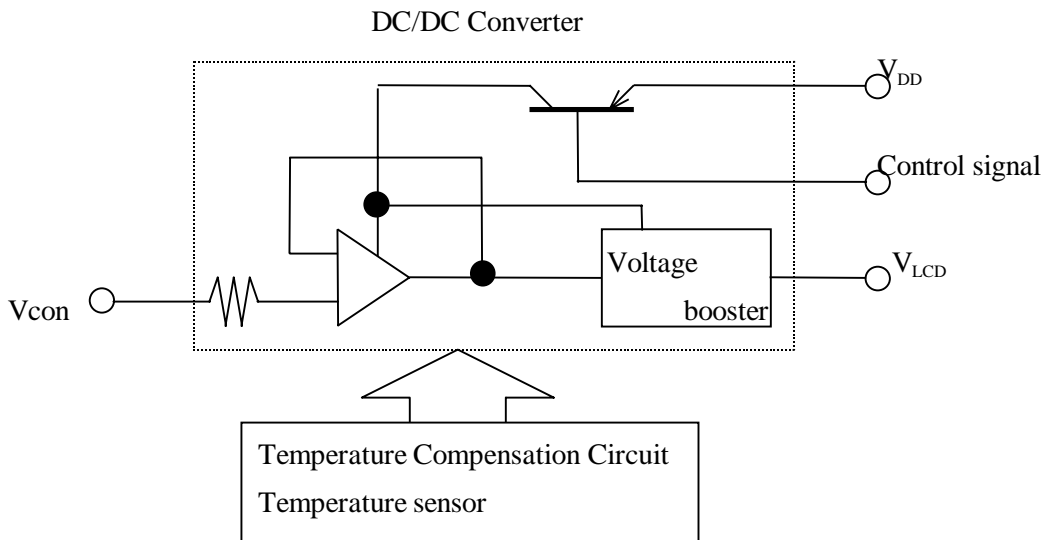

5-2.Interface signals

○LCD

Table 6

Pin No.	Symbol	Description	Level
1	VSS	Ground potential	-
2	YD	Scan start-up signal	"H"
3	VSS	Ground potential	-
4	LP	Input data latch signal	"H" → "L"
5	VSS	Ground potential	-
6	XCK	Data input clock signal	"H" → "L"
7	VSS	Ground potential	-
8	Vcon	Contrast adjust voltage	-
9	DISP	Display control signal	H(ON), L(OFF)
10	VDD	Power supply for logic and LCD	-
11	VDD	Power supply for logic and LCD	-
12	VDD	Power supply for logic and LCD	-
13	VSS	Ground potential	-
14	DU0	Display data signal (Upper)	H(ON), L(OFF)
15	DU1	Display data signal (Upper)	H(ON), L(OFF)
16	DU2	Display data signal (Upper)	H(ON), L(OFF)
17	DU3	Display data signal (Upper)	H(ON), L(OFF)
18	DU4	Display data signal (Upper)	H(ON), L(OFF)
19	DU5	Display data signal (Upper)	H(ON), L(OFF)
20	DU6	Display data signal (Upper)	H(ON), L(OFF)
21	DU7	Display data signal (Upper)	H(ON), L(OFF)
22	VSS	Ground potential	-
23	DL0	Display data signal (Lower)	H(ON), L(OFF)
24	DL1	Display data signal (Lower)	H(ON), L(OFF)
25	DL2	Display data signal (Lower)	H(ON), L(OFF)
26	DL3	Display data signal (Lower)	H(ON), L(OFF)
27	DL4	Display data signal (Lower)	H(ON), L(OFF)
28	DL5	Display data signal (Lower)	H(ON), L(OFF)
29	DL6	Display data signal (Lower)	H(ON), L(OFF)
30	DL7	Display data signal (Lower)	H(ON), L(OFF)
31	NC	Non Connection	-

○CCFT

Pin No	Symbol	Description	Level
1	HV	High voltage line (from Inverter)	-
2	NC	-	-
3	GND	Ground line (from Inverter)	-

○LCD

Used connector : FI-W31P-HF(JAE)

Correspondable connector : FI-W31S (JAE)

○CCFT

Used connector : BHR-03VS-1 (JST)

Correspondable connector : SM02(8.0)B-BHS(JST)

Except above connector shall be out of guaranty.

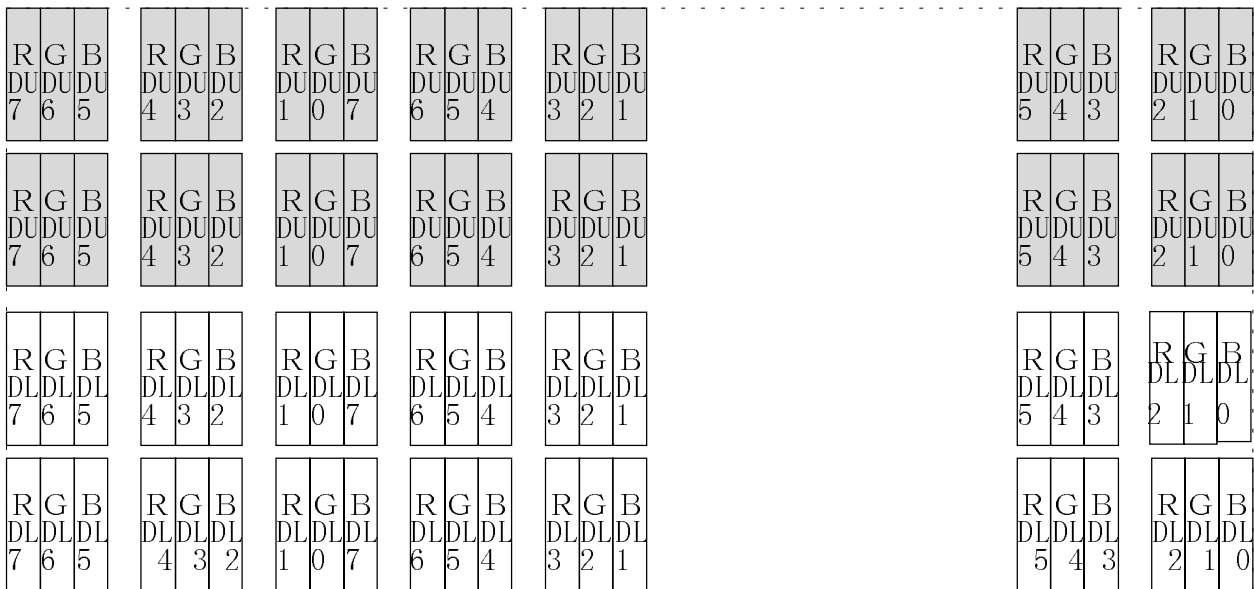
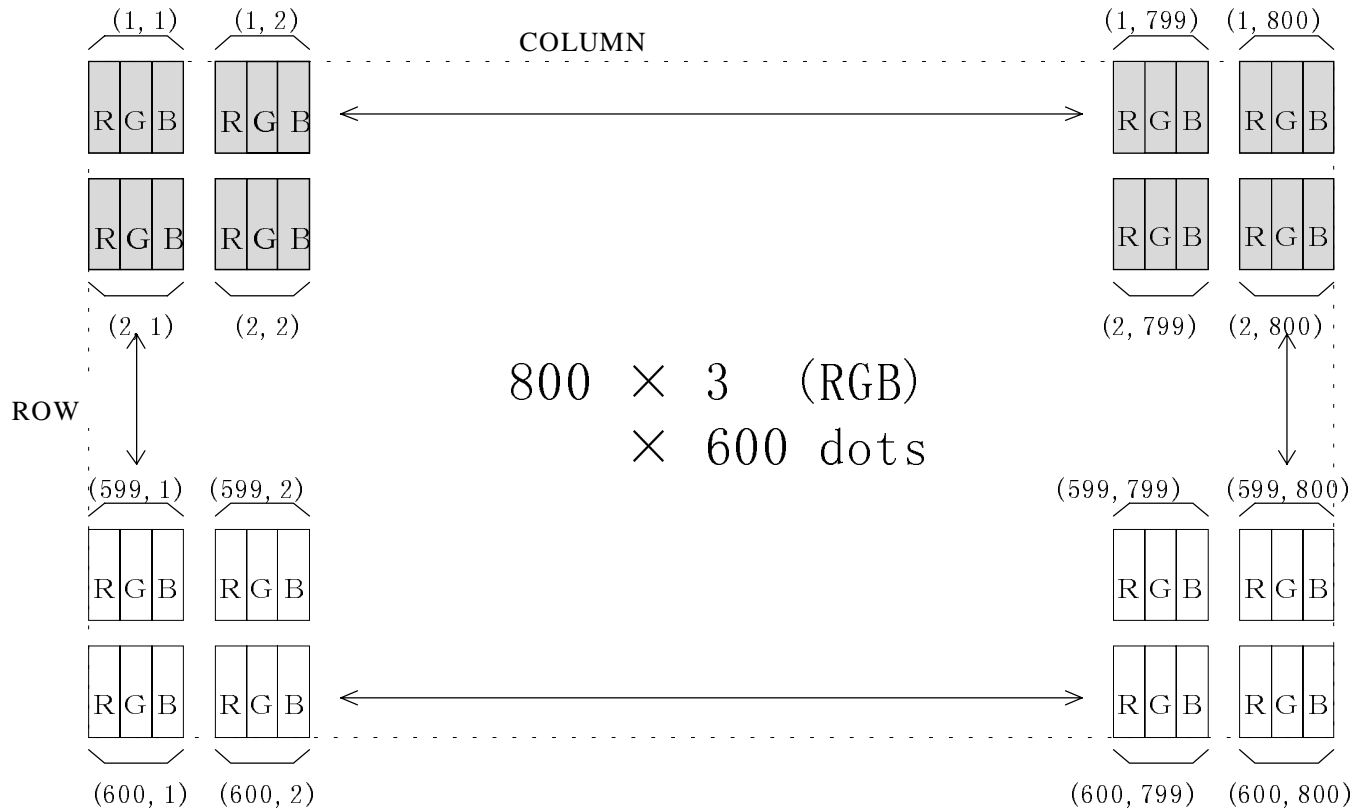

Upper SEG Drivers , Upper data(DU0-7)
 Lower SEG Drivers , Lower data(DL0-7)

Fig.2 Dot chart of display area

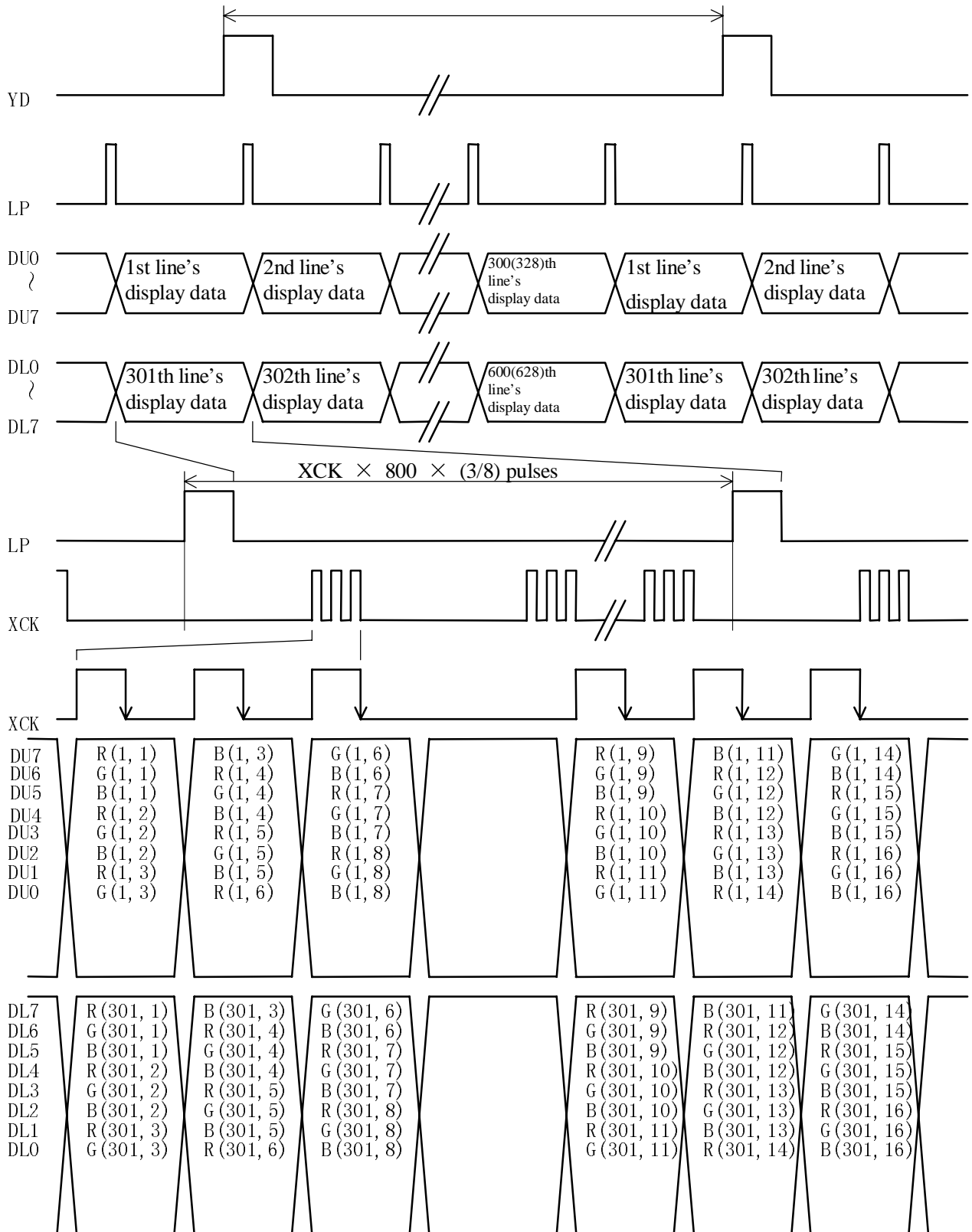

*Electrical and optical characteristics are specified by above condition.

Fig. 3 Data input timing chart

(NOTE 1) In order to keep operating LCD display during "A" period, DISP signal should be "H" level so that

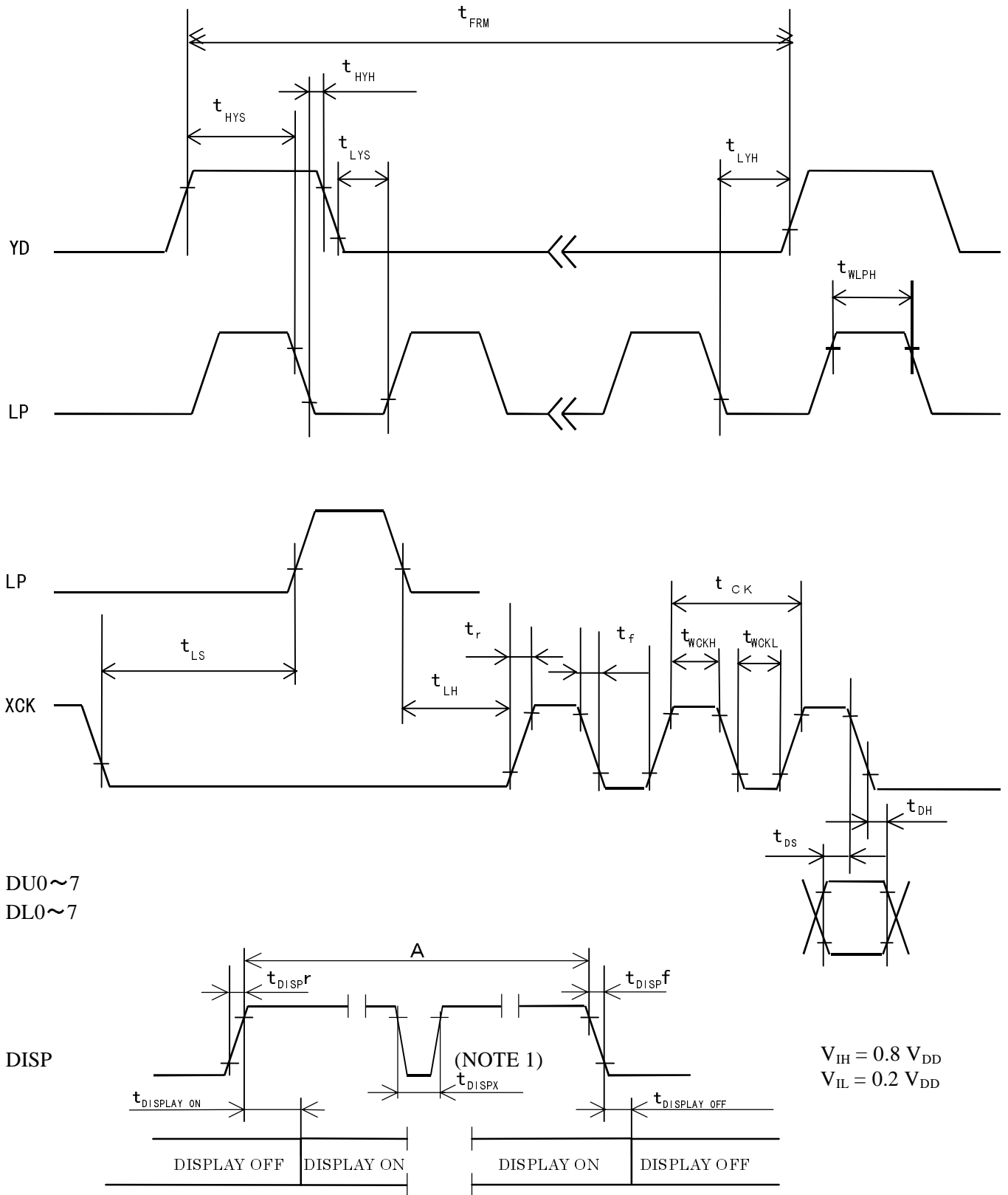

Fig.4 Interface timing chart

$V_{IH}(0.8V_{DD})$ do not break into the line. $t_{DISPX} = 0$ ns Max.

Table 7 Interface timing ratings

Ta=0~40 °C, VDD=3.3±0.3V

Item	Symbol	Rating			Unit
		MIN.	TYP.	MAX.	
Frame cycle *2	t _{FRM}	6.66		16.94	ms
XCK signal clock cycle	T _{CK}	50			ns
“H” level clock width	t _{WCKH}	20			ns
“L” level clock width	t _{WCKL}	20			ns
LP signal clock cycle	T _{LP}			70	μs
LP signal “H” level pulse width	t _{WLPH}	200			ns
Data set up time	T _{DS}	15			ns
hold time	T _{DH}	23			ns
YD signal “H” level set up time	t _{HYS}	100			ns
“H” level hold time	t _{HYH}	100			ns
“L” level set up time	t _{LYS}	100			ns
“L” level hold time	t _{LYH}	40			ns
LP ↑ allowance time from XCK ↓	T _{LS}	200			ns
XCK ↑ allowance time from LP ↓	T _{LH}	200			ns
Input signal rise/fall time *1	T _r , t _f			13	ns
DISP signal rise/fall time	t _{DISP_r} , t _{DISP_f}			100	ns
DISPLAY ON from DISP ↑	t _{DISPLAY ON}			350	ms
DISPLAY OFF from DISP ↓	t _{DISPLAY OFF}			150	ms

- *1 When LCD module is operated by high speed of XCK(Shift clock), $(t_{CK} - t_{WCKH} - t_{WCKL}) / 2$ is maximum.
- *2 As for the specification of frame cycle, it is required to keep the conditions of the other Interface timing ratings. The shadowing is adjusted on this module to the following conditions. When LCD module is operated in the other conditions, that should be informed in advance because display quality may be deteriorated in this case.

Frame frequency : 120 Hz(Frame cycle : 8.33 ms)

Owing to the characteristics of LCD module, “shadowing” will become more eminent as frame frequency goes up, while flicker will be reduced.

since judgment of display quality is subjective and display quality such as “shadowing” is pattern dependent, it is recommended that decision of frame frequency, to which power consumption of the LCD module is proportional, be made based on your own through testing on the LCD module with every possible patterns displayed on it

- ※ The intervals of one LP fall and next must be always the same, and LPs must be input continuously.
The intervals must be 70 μs Max

6. Module Driving Method

6-1. Circuit configuration

Fig.10 shows the block diagram of the module's circuitry.

6-2. Display face configuration

The display consists of $800 \times 3(R,G,B) \times 600$ dots as shown in Fig. 2.

The interface is single panel with double drive to be driven at 1/300(1/328) duty ratio.

(1/300:an odd number frame, 1/328:an even number frame)

6-3. Input data and control signal

The LCD driver is 240 bits LSI, consisting of shift registers, latch circuits and LCD driver circuits. Input data for each row ($800 \times 3 R,G,B$) will be sequentially transferred in the form of 8 bit parallel data through shift registers from top left of the display together with clock signal (XCK).

When input of one row ($800 \times 3 R,G,B$) is completed, the data will be latched in the form of parallel data corresponding to the signal electrodes by the falling edge of latch signal (LP) then, the corresponding drive signals will be transmitted to the 800×3 lines of column electrodes of the LCD panel by the LCD drive circuits.

At this time, scan start-up signal (YD) has been transferred from the scan signal driver to the 1st row of scan electrodes, and the contents of the data signals are displayed on the 1st row of the display face according to the combinations of voltages applied to the scan and signal electrodes of the LCD. While the data of 1st row are being displayed, the data of 2nd row are entered. When data for 800×3 dots have been transferred, they will be latched by the falling edge of LP, switching the display to the 2nd row.

Such data input will be repeated up to the 300(328)th row of each display segment, from upper row to lower rows, to complete one frame of display by time sharing method.

Simultaneously the same scanning sequence occur at the lower panel.

Then data input proceeds to the next display frame.

YD generates scan signal to drive horizontal electrodes.

Since DC voltage, if applied to LCD panel, causes chemical reaction in LC materials, causing deterioration of the materials, drive wave-form shall be inverted at every display frame to prevent the generation of such DC voltage. Control signal M plays such a role.

Because of the characteristics of the CMOS driver LSI, the power consumption of the display module goes up with the clock frequency of XCK.

To minimize data transfer speed of XCK clock the LSI has the system of transferring 8 bit parallel data through the 8 lines of shift registers.

Thanks to this system the power consumption of the display module is minimized.

In this circuit configuration, 8 bit display data shall input to data input pins of DU0-7 and DL0-7.

Furthermore, the display module has bus line system for data input to minimize the power consumption with data input terminals of each driver LSI being activated only when relevant data input is fed.

Data input for column electrodes and chip select of driver LSI are made as follows:

The driver LSI at the left end of the display face is first selected, and the adjacent driver LSI right next side is selected when data of 240 dot (30XCK) is fed. This process is sequentially continued until data is fed to the driver LSI at the right end of the display face. This process is followed simultaneously both at the top and bottom column drivers LSI's.

Thus data input will be made through 8 bit bus line sequentially from the left end of the display face.

Since this display module contains no refresh RAM, it requires the above data and timing pulse inputs even for static display.

The timing chart of input signals are shown in fig. 4 and Table 8.

7. Optical Characteristics

Following spec are based upon the electrical measuring conditions, on which the contrast of perpendicular direction ($\theta_x = \theta_y = 0^\circ$) will be MAX..

Table 8

$T_a = 25^\circ\text{C}$, $V_{DD} = 3.3\text{V}$, $V_{con} - V_{SS} = V_{max}$

Parameter		Symbol	Condition	MIN.	TYP.	MAX.	Unit	Remark
Viewing angle range		θ_x	$Co > 5.0$	$\theta_y = 0^\circ$	-30	-	30	Note 1)
		θ_y		$\theta_x = 0^\circ$	-15	-	25	
Contrast ratio		Co	$\theta_x = \theta_y = 0^\circ$	-	50	-	-	Note 2)
Response time	Rise	τ_r	$\theta_x = \theta_y = 0^\circ$	-	220	-	ms	Note 3)
	Decay	τ_d	$\theta_x = \theta_y = 0^\circ$	-	80	-	ms	
Module Chromaticity	White	x	$\theta_x = \theta_y = 0^\circ$	-	0.300	-	-	
		y	$\theta_x = \theta_y = 0^\circ$	-	0.340	-	-	

Note 1) The viewing angle range is defined as shown Fig.5.

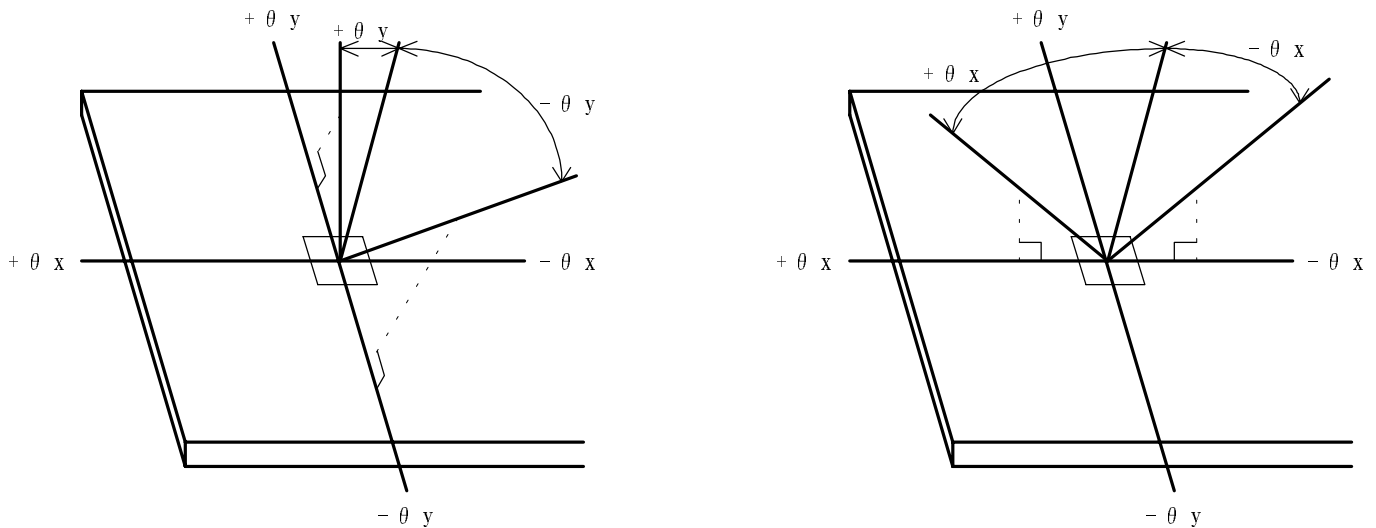

Fig.5 Definition of Viewing Angle

Note 2) Contrast ratio is defined as follows:

$$Co = \frac{\text{Luminance(brightness) all pixes "White" at } V_{max}}{\text{Luminance(brightness) all pixes "dark " at } V_{max}}$$

V_{max} is defined in Fig.7.

Note 3) The response characteristics of photo-detector output are measured as shown in Fig.8, assuming that input signals are applied so as to select and deselect the dot to be measured, in the optical characteristics test method shown in Fig.9.

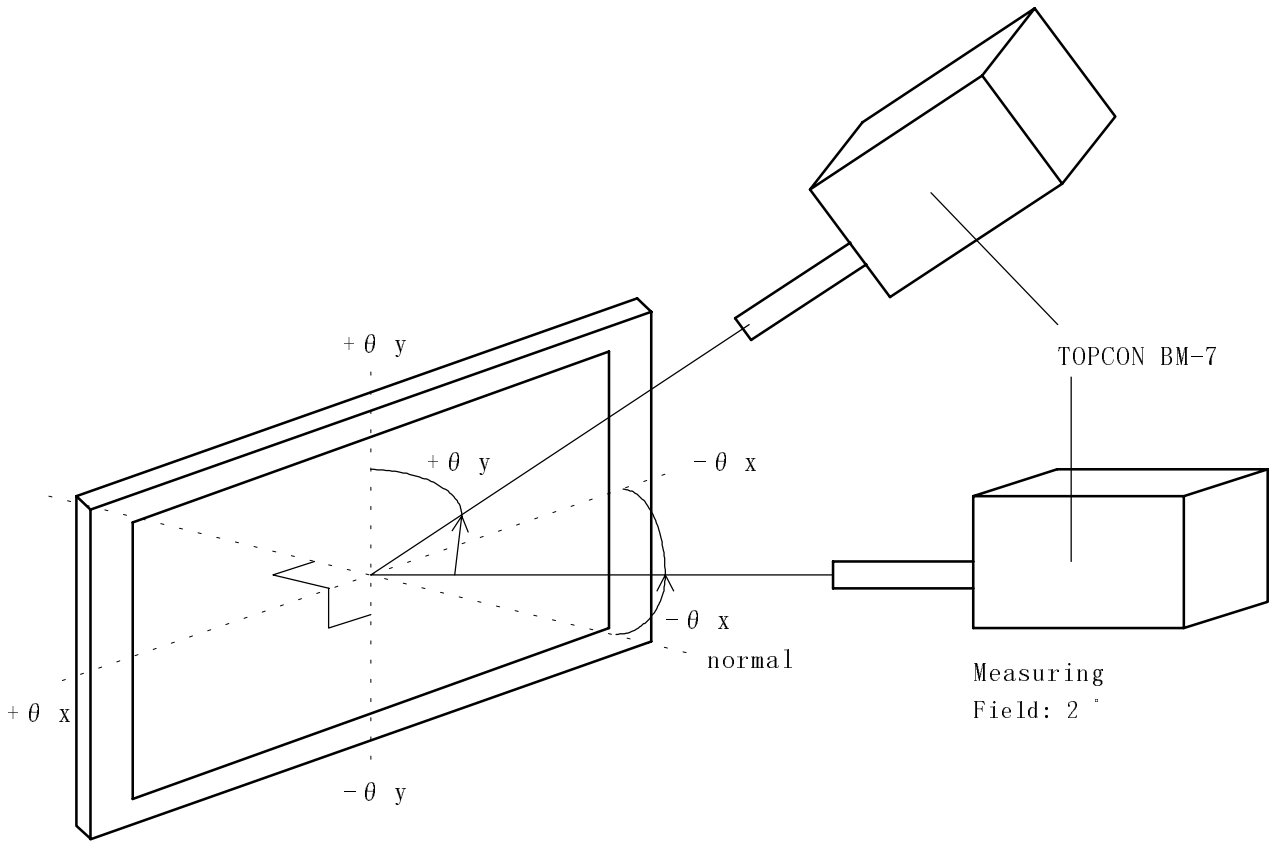

Measuring Spot Size : ϕ 10 mm

θ_x : Angle from "normal" to viewing surface rotated about the horizontal axis.

θ_y : Angle from "normal" to viewing surface rotated about the vertical axis.

Fig.6 Optical Characteristics Test Method I

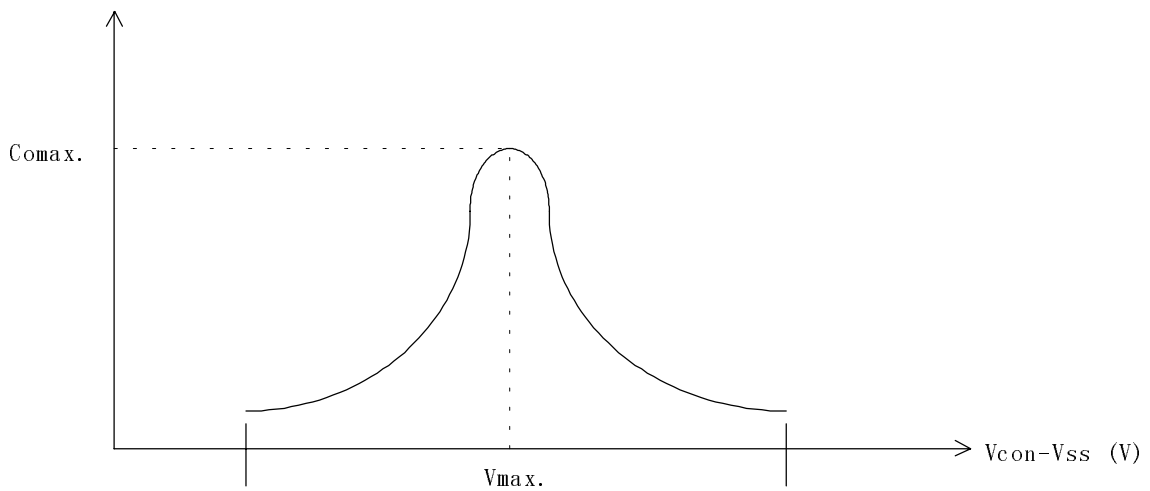
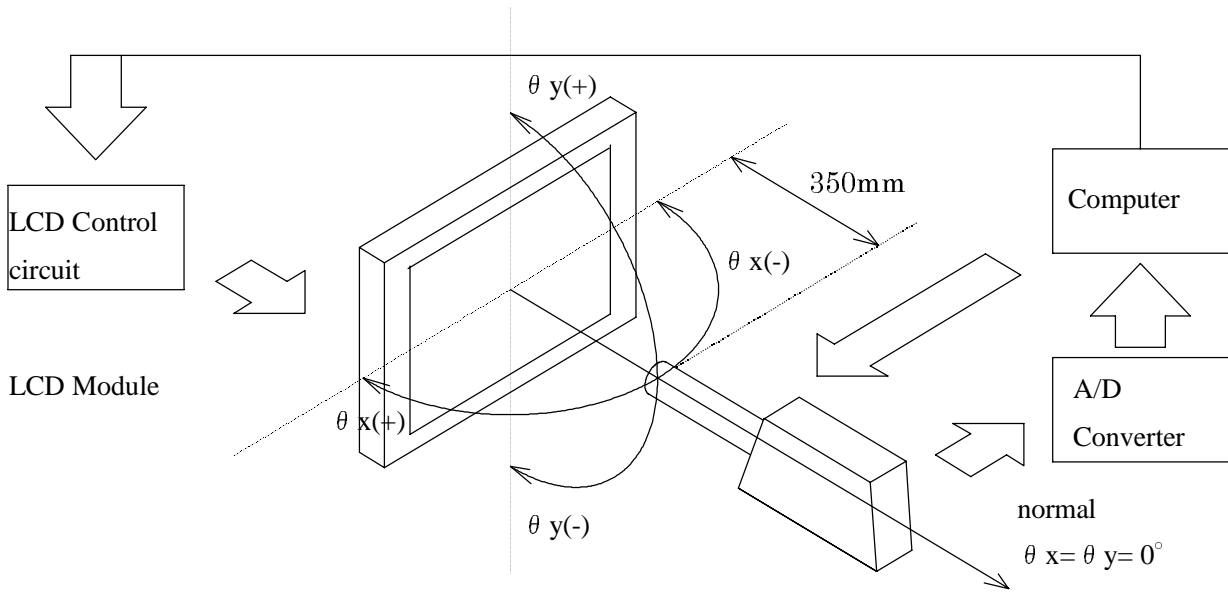

Fig.7 Definition of Vmax

(Response Measurement)

Ta = 25 °C

In dark room



TOPCON BM7

(Measuring spot size : ϕ 10 mm, Measuring Field : 2 °)

Fig. 8 Optical Characteristics Test Method II

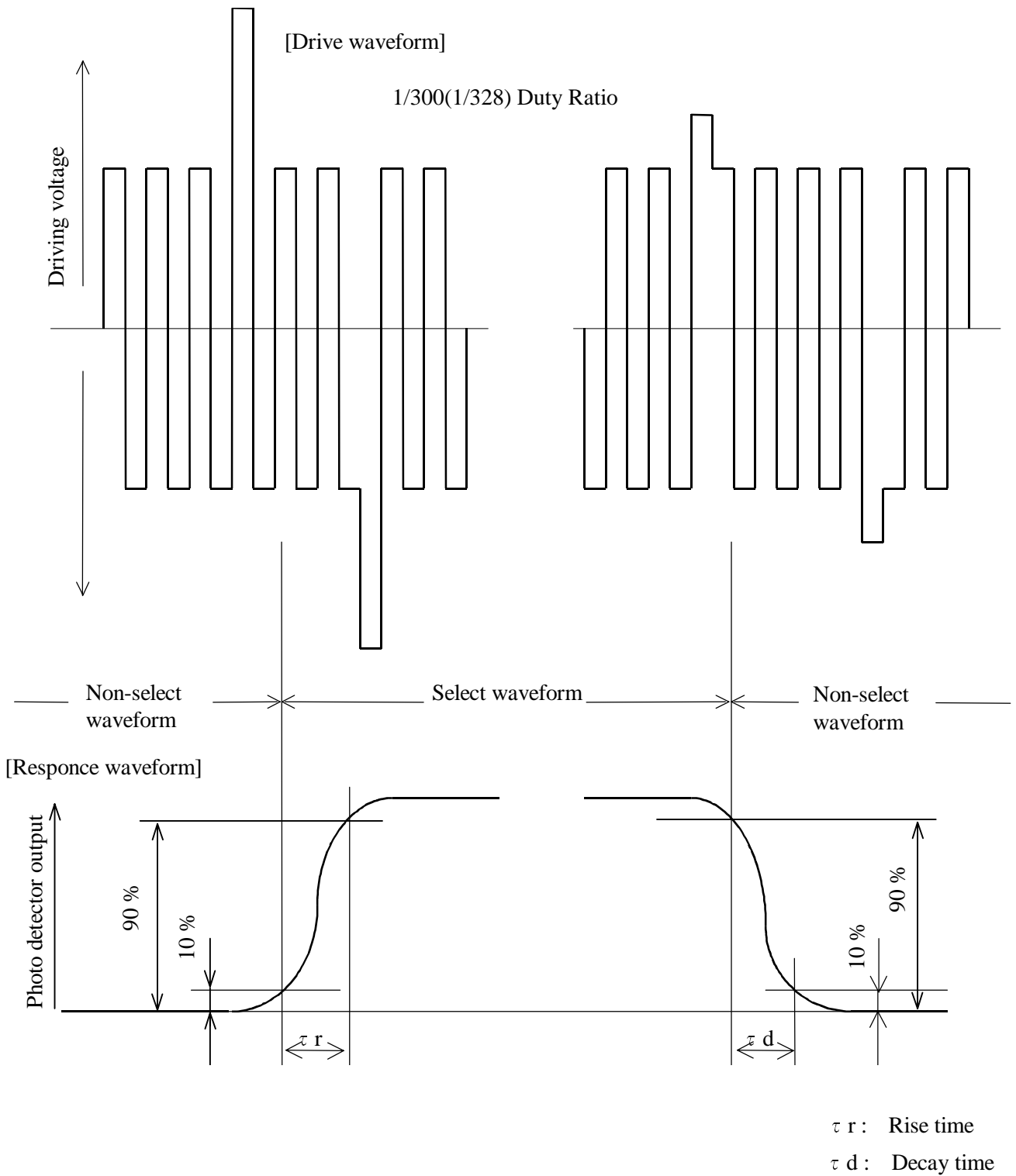

Fig.9 Definition of Response time

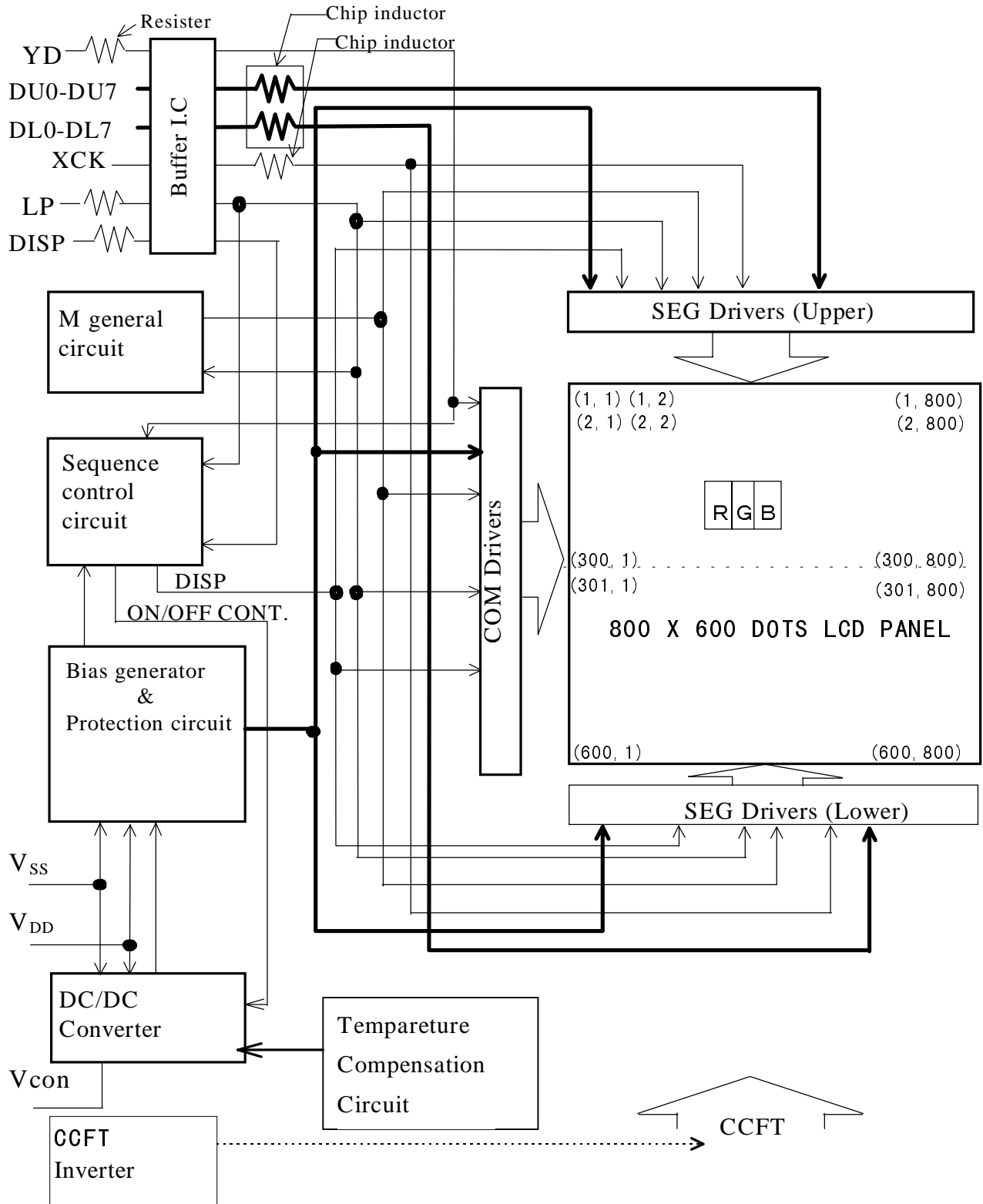

Fig. 10 Circuit block diagram

8.Characteristics of Backlight

The ratings are given on condition that the following conditions are satisfied.

1) Rating(Note)

Parameter	MIN.	TYP.	MAX.	Unit
Brightness	75	100	-	cd/m ²

2) Measurement circuit : CXA-L0612-VJL(TDK) at IL = 4.3 mArms

3) Measurement equipment : BM-7 (TOPCON Corporation)

4) Measurement conditions

4-1. Measurement circuit voltage : DC = 12.0 V, at primary side

4-2. LCD: All digits WHITE, VDD= 3.3 V, Vcon-VSS = Vmax, DU0-7="H"(White),DL0-7="H"(White)
Frame Frequency 120 Hz

4-3. Ambient temperature : 25 °C

Measurement shall be executed 30 minutes after turning on.

5) Used lamp : HMBTM2JD91F217.5NLH/AX (HARISON)(φ 2.0mm)

Used cable : UL3587, AWG26 (NISSEI ELECTRIC CO.,LTD.)

UL1430, AWG26 (SUMITOMO ELECTRIC INDUSTRIES LTD.)

5-1. Rating (1pc)

Parameter	Symbol	MIN.	TYP.	MAX.	Unit	Remark
Lamp voltage	V _L	-	555	-	Vrms	-
Lamp current	I _L	-	4.3	5.0	mArms	*1
Lamp power consumption	P _L	-	2.40	-	W	*2
Lamp frequency	F _L	40	-	100	kHz	-
Kick-off voltage	V _s	-	-	850	Vrms	Ta=25 °C
		-	-	1050	Vrms	Ta= 0 °C
Lamp life time	L _L	15 000	25000	-	H	-

Within no conductor closed. (CCFT only)

*1 It is recommended that IL be not more than 5.0 mArms so that heat radiation of CCFT backlight may least affect the display quality.

*2 Power consumption excluded inverter loss.

*3 The circuit voltage(VS) of the inverter should be designed to have some margin, because VS may be increased due to the leak current in case of the LCD module.

*4 Average life time of CCFT will be decreased when LCD is operating at lower temperature.

5-2. Operating life

The operating life time is 15 000 hours or more at 5.0 mArms MAX., at 25°C. (Operating life with CXA-L0612-VJL or equivalent.)

The inverter should meet the following conditions to keep the specified life time of used lamp;

- Since, symmetric waveform without spike in positive and negative
- Output frequency range 40 kHz- 100 kHz

Make sure the operating conditions by executing the burn-in enough time.

The operating life time is defined as having ended when any of the following conditions occur; $25 \pm 1 \text{ }^\circ\text{C}$

- When the voltage required for initial discharge has reached 110 % of the initials value.
- When the illuminance quantity of light has decreased to 50 % of the initials value.

(NOTE) Rating are defined as the average brightness inside the viewing area specified in Fig.11.

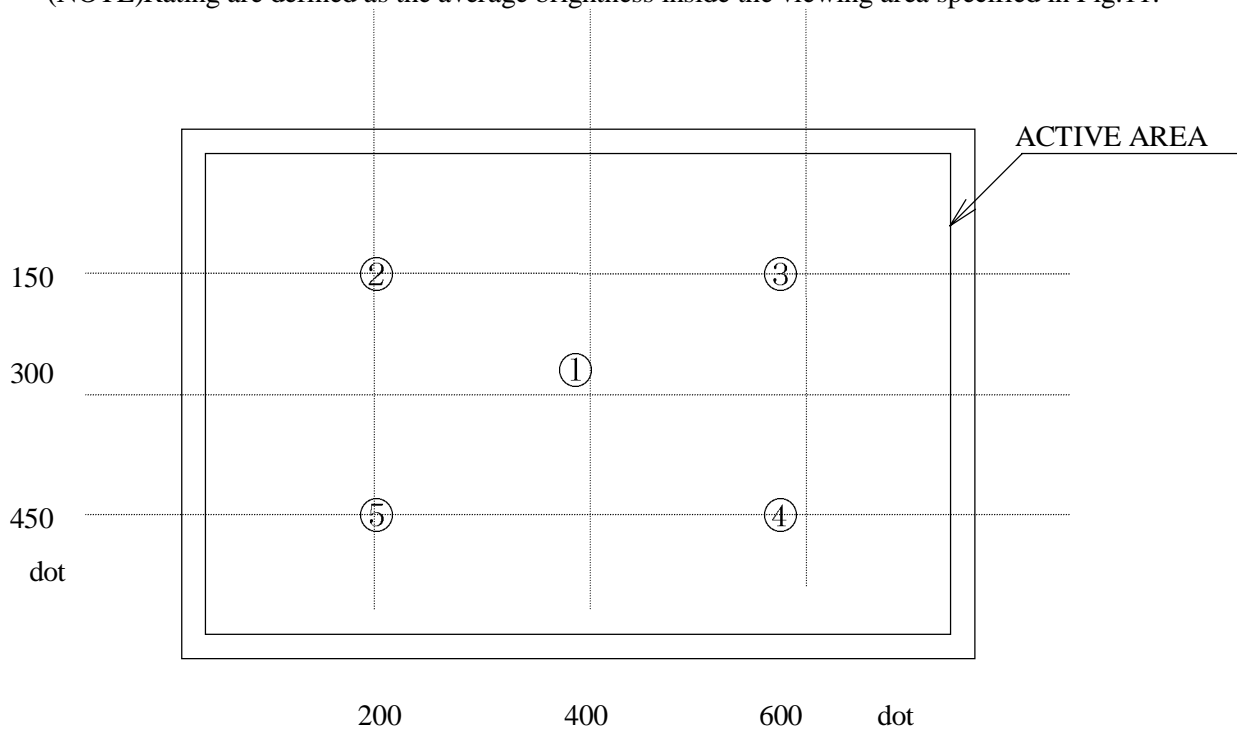
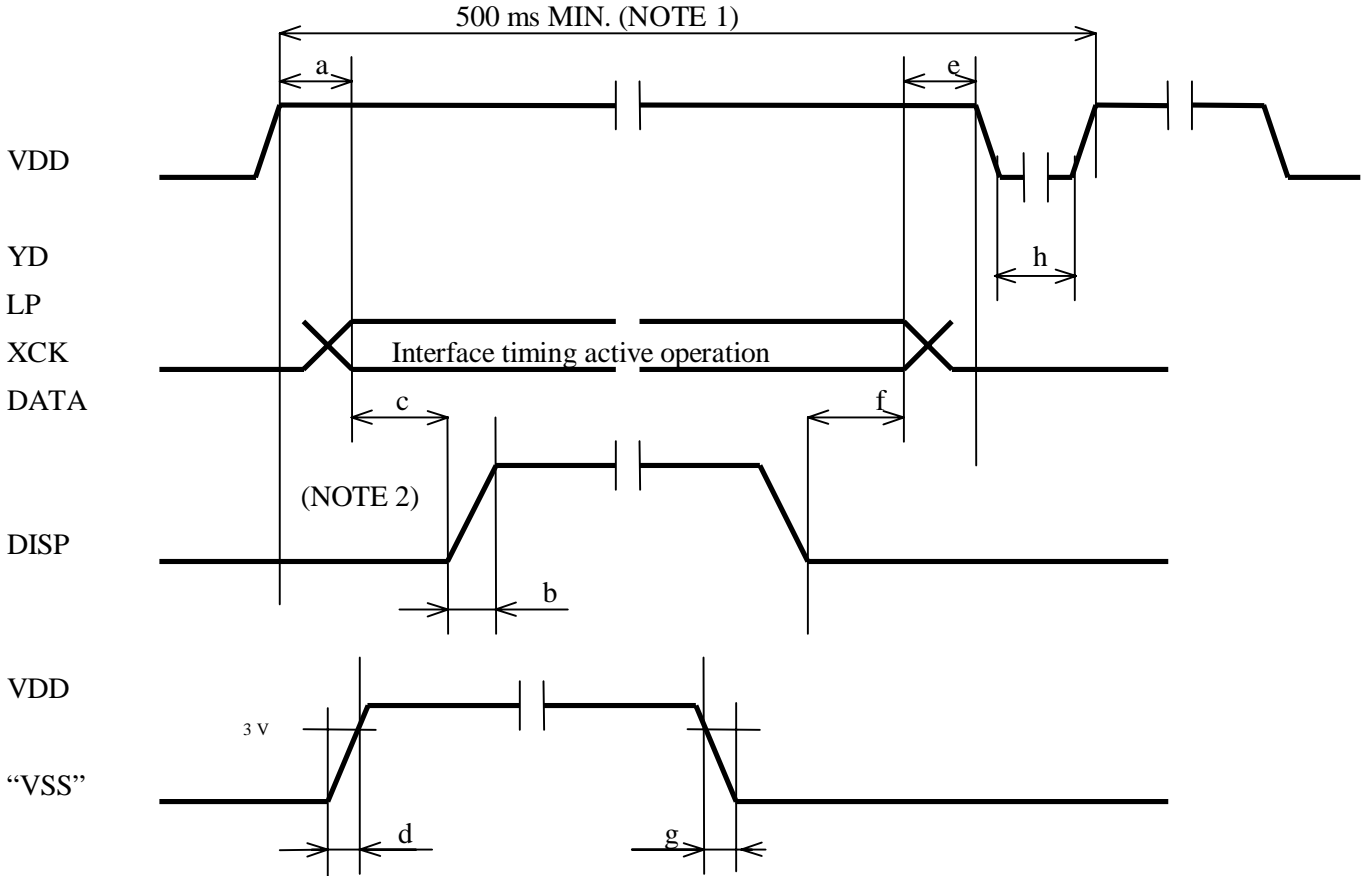

Fig.11 Measuring points (1-5)

9.ON/OFF voltage sequence condition



POWER ON		
Symbol	Allowable value	
a	0 ms MIN.	1 s MAX.
b	—	100 ns MAX.
c	50 ms MIN.	—
d	—	10 ms MAX.

POWER OFF		
Symbol	Allowable value	
e	0 ms MIN.	1 s MAX.
f	0 ms MIN.	—
g	2ms MIN.	250 ms MAX.
h	250 ms MIN.	—

Fig.12 Supply voltage sequence condition

(NOTE 1) Power ON/OFF cycle time. All signals and power line shall be in accordance with above sequence in case of power ON/OFF.

(NOTE 2) Before DISP rise up, the signals of YD,LP,XCK,DATA must be input, and the above condition of “a” must be satisfied. The signals which comply with the interface timing in Fig.3, Fig.4, and table 6, must be input.

10.Applicable inspection standard

The LCD module shall meet the following inspection standard : S-U-035-08

Lot number is shown at the position mentioned in Fig.13 in accordance with the following numbering rule.

(Example) 00 F 00001

- Serial number (Missing number exist)
- Productionmonth(A=Jan.,B=Feb.,...,L=Dec.)
- Production year

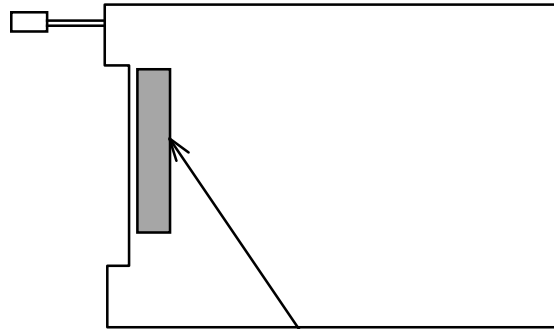
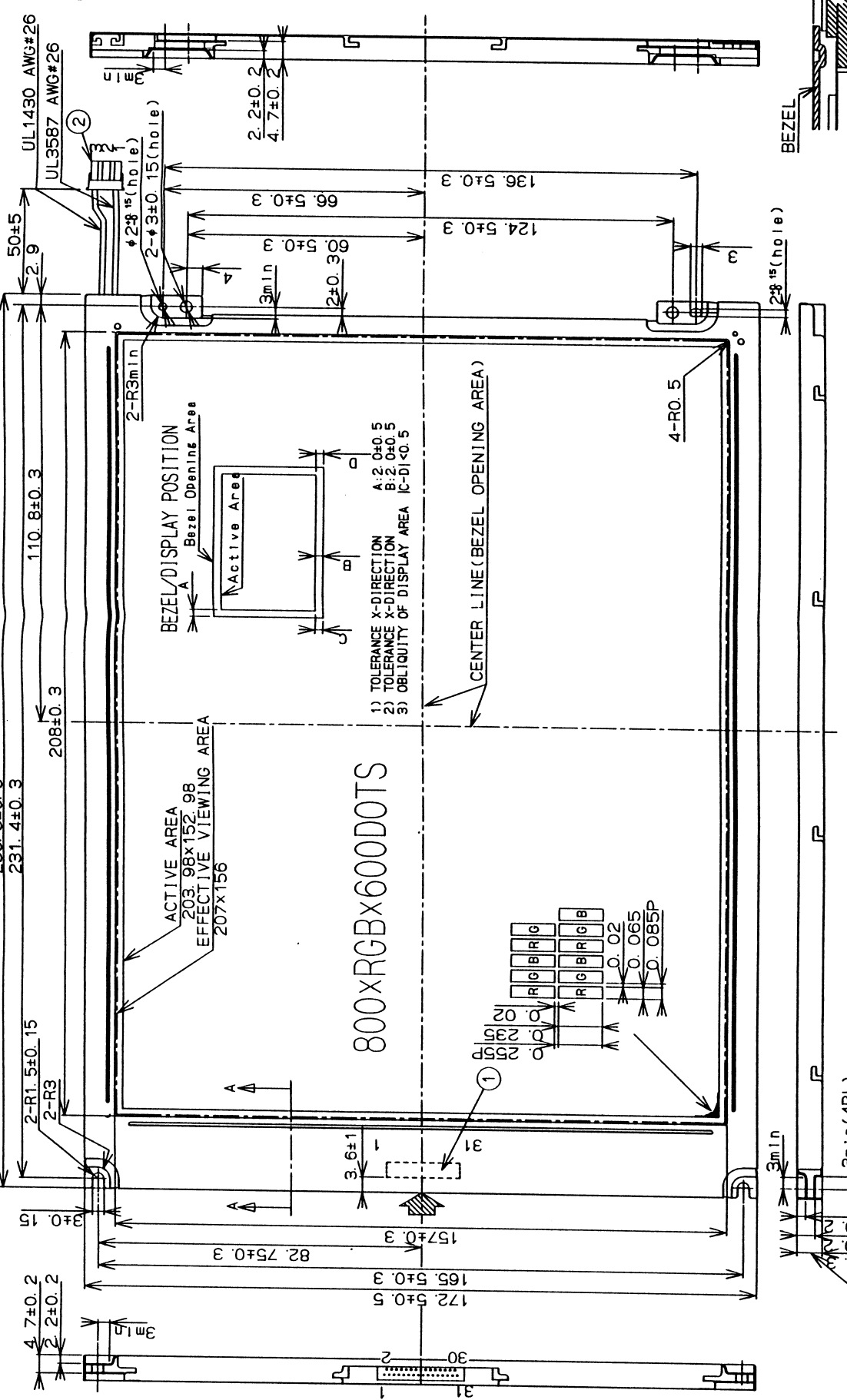

Fig.13

Model and Serial number

② CCFT CONNECTOR
BHR-03VS-1(JST)
PIN LAYOUT

1	2	3
HV	NC	GND



- 1) TOLERANCE X-DIRECTION A: 2.0±0.5
2) TOLERANCE X-DIRECTION B: 2.0±0.5
3) OBLIQUITY OF DISPLAY AREA (C-D) < 0.5

CENTER LINE (BEZEL OPENING AREA)

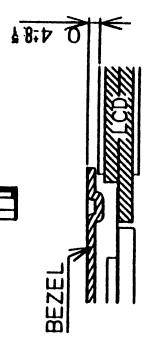

Unspecified tol to be ±0.5mm

NAME	LM100SS1T522	SYMBOL	800XRGBX600
PREPA MODEL		PARTS CODE	
SCALE		DATE	1999.8.31
DATE		DESIGN	SHARP CORPORATION
REVISE		CHECK	ENGINEERING DEPARTMENT
FINISH		APPROVE	DUTY LCD DEVELOPMENT CENTER
MATERIAL THICKNESS		M.	DUTY LIQUID CRYSTAL DISPLAY GROUP

① INTERFACE CONNECTOR
FI-W31P-HF (JAE)

Pin No.	1	2	3	4	5	6	7	8	9	10	11	12	13	14	15	
Signal	VSS	YD	VSS	LP	VSS	XCK	VSS	VCON	D1SP	VDD	VDD	VDD	VSS	D10	D11	
Pin No.	16	17	18	19	20	21	22	23	24	25	26	27	28	29	30	31
Signal	D12	D13	D14	D15	D16	D17	VSS	D10	D11	D12	D13	D14	D15	D16	D17	VSS

This value shows the thickness after mounting and fixing to customer's cabinet.
Excluded the allowance of deformation

FREE SPACE AREA FOR SCREW BOSS