

Product Specification

SPECIFICATION FOR APPROVAL

() Preliminary Specification
 () Final Specification

Title	26" WXGA TFT LCD
--------------	-------------------------

BUYER	General
MODEL	

SUPPLIER	LG.Philips LCD CO., Ltd.
*MODEL	LC260WX2
SUFFIX	SL01

*When you obtain standard approval,
please use the above model name without suffix

APPROVED BY	SIGNATURE	DATE
/	_____	_____
/	_____	_____
/	_____	_____

APPROVED BY	SIGNATURE	DATE
Jay Yoon / G.Manager	_____	_____
REVIEWED BY		
K.N Kim / Manager	_____	_____
PREPARED BY		
Y.S Kang / Engineer	_____	_____

Please return 1 copy for your confirmation with your signature and comments.

TV Products Engineering Dept.
LG. Philips LCD Co., Ltd

Product Specification

CONTENTS

NO.	ITEM	Page
-	COVER	1
-	CONTENTS	2
-	RECORD OF REVISIONS	3
1	GENERAL DESCRIPTION	4
2	ABSOLUTE MAXIMUM RATINGS	5
3	ELECTRICAL SPECIFICATIONS	6
1	ELECTRICAL CHARACTREISTICS	6
2	INTERFACE CONNECTIONS	8
3	SIGNAL TIMING SPECIFICATIONS	12
4	SIGNAL TIMING WAVEFORMS	13
5	COLOR INPUT DATA REFERNECE	14
6	POWER SEQUENCE	15
4	OPTICAL SFECIFICATIONS	17
5	MECHANICAL CHARACTERISTICS	21
6	RELIABLITY	24
7	INTERNATIONAL STANDARDS	25
1	SAFETY	
2	EMC	
8	PACKING	26
1	DESIGNATION OF LOT MARK	
2	PACKING FORM	
9	PRECAUTIONS	27

Product Specification

1. General Description

The LC260W02 is a Color Active Matrix Liquid Crystal Display with an integral External Electrode Fluorescent Lamp(EEFL) backlight system. The matrix employs a-Si Thin Film Transistor as the active element. It is a transmissive type display operating in the normally black mode. This TFT-LCD has a 26.0 inch diagonally measured active display area with WXGA resolution (768 vertical by 1366 horizontal pixel array). Each pixel is divided into Red, Green and Blue sub-pixels or dots which are arranged in vertical stripes. Gray scale or the luminance of the sub-pixel color is determined with a 8-bit gray scale signal for each dot, thus, presenting a palette of more than 16,7M(True) colors. The LC260W02 has been designed to apply the LVDS interface. It is intended to support LCD TV, PCTV where high brightness, super wide viewing angle, high color gamut, high color depth, and fast response time are important.

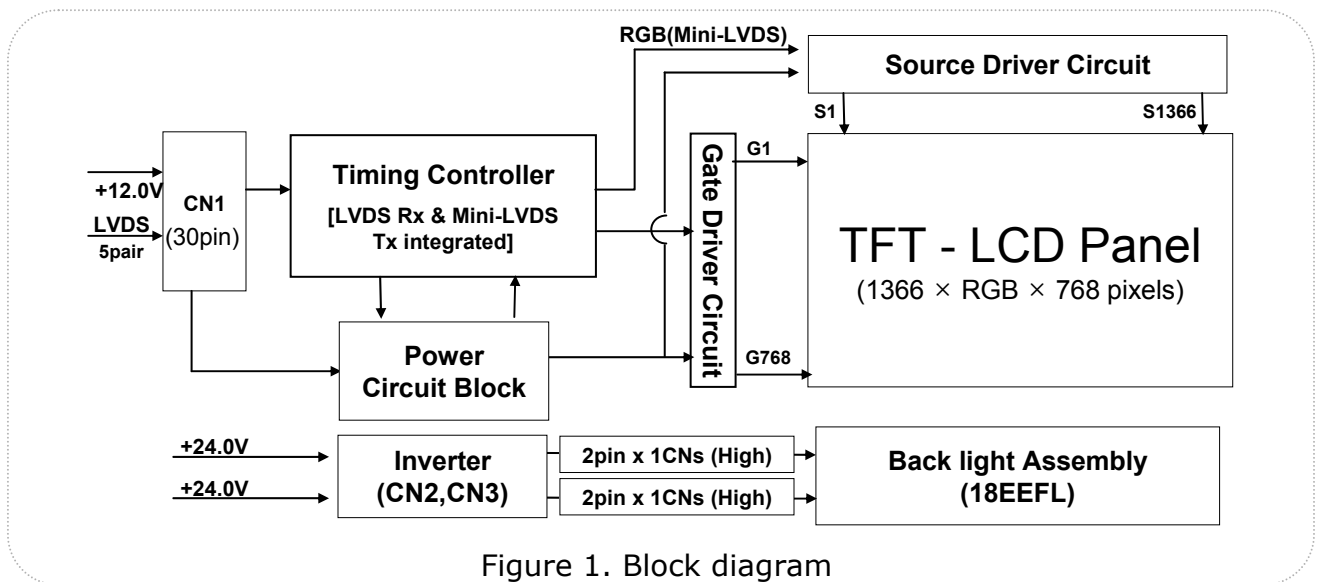

Figure 1. Block diagram

General Features

Active screen size	26.0 inches(660.53mm) diagonal
Outline Dimension	626.0(H) x 373.0(V) x 44.1(D) mm(Typ.)
Pixel Pitch	0.4215 mm x 0.1405 mm x RGB
Pixel Format	1366 horizontal by 768 vertical pixels. RGB stripe arrangement
Interface	LVDS
Color depth	8-bit, 16,777,216 colors
Luminance, white	500 cd/m ² (Center 1 point, Typ.)
Viewing Angle (CR>10)	Viewing Angle Free(R/L 178(Typ.), U/D 178(Typ.))
Power Consumption	Total TBD Watt(Typ.), (3.0 Watt @V _{LCD} , TBD Watt @V _{BL})
Weight	5000 g (Typ.)
Display operating mode	Transmissive mode, normally black
Surface treatments	Hard coating (3H), Anti-glare treatment of the front polarizer

Product Specification

2. Absolute Maximum Ratings

Table 1. Absolute Maximum Ratings

Parameter	Symbol	Value		Unit	Note
		Min	Max		
Power Supply Input Voltage	V _{LCD}	-0.3	+14	V _{dc}	At 25°C
	V _{BL}	-0.3	+27	V _{dc}	
On/Off Control Voltage	ON/OFF	-0.3	+5.25	V _{dc}	
Brightness Control Voltage	V _{BR}	0	+3.3	V _{dc}	
Operating Temperature	T _{OP}	0	+40	°C	1
Storage Temperature	T _{ST}	-20	+50	°C	1
Operating Ambient Humidity	H _{OP}	10	90	%RH	1
Storage Humidity	H _{ST}	10	90	%RH	1

Note :

1. Temperature and relative humidity range are shown in the figure below. Wet bulb temperature should be 39 °C Max, and no condensation.

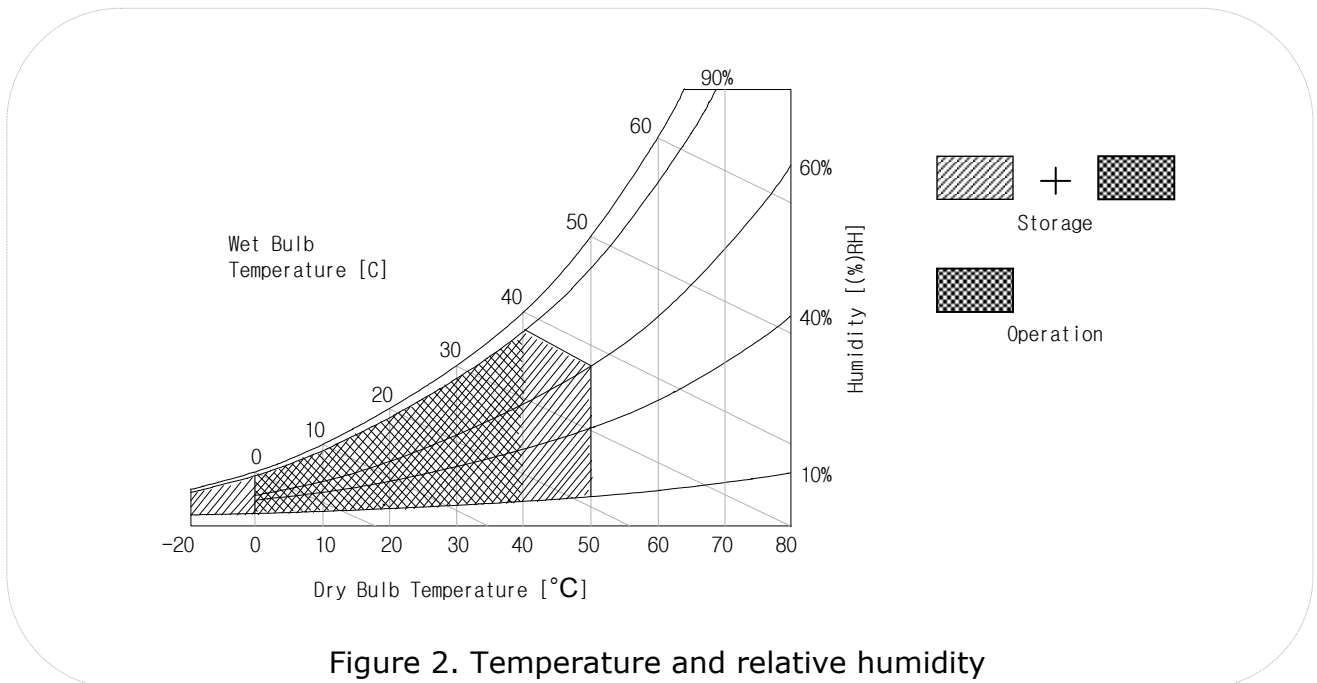

Figure 2. Temperature and relative humidity

Product Specification

3. Electrical Specifications

The LC260W02 requires two power inputs. One is employed to power the LCD electronics and to drive the TFT array and liquid crystal. The second input power for the EEFL/Backlight, is to power the inverter.

3-1. Electrical Characteristics

Table 2. Electrical Characteristics

Parameter	Symbol	Value			Unit	Note
		Min	Typ	Max		
1. Power for Panel:						
Power Supply Input Voltage	V_{LCD}	11.4	12.0	12.6	Vdc	
Power Supply Input Current	I_{LCD}	-	250	325	mA	1
		-	320	420	mA	2
Power Consumption	P_{LCD}	-	3.0	3.9	Watt	1
Inrush Current (V_{LCD} Input)	I_{RUSH}	-	-	3	A	3

Notes:

1. The specified current and power consumption are under the $V_{LCD}=12V$, $25^{\circ}C$, $fV(\text{frame frequency})=60\text{Hz}$ condition. Typical supply current is measured at the condition of 8 X 6 Mosaic pattern(white & black) shown in the [Figure 3] is displayed.
2. The current is specified at te maximum current pattern(White).
3. The duration of rush current is about 2ms and rising time of power input is 1ms(min).

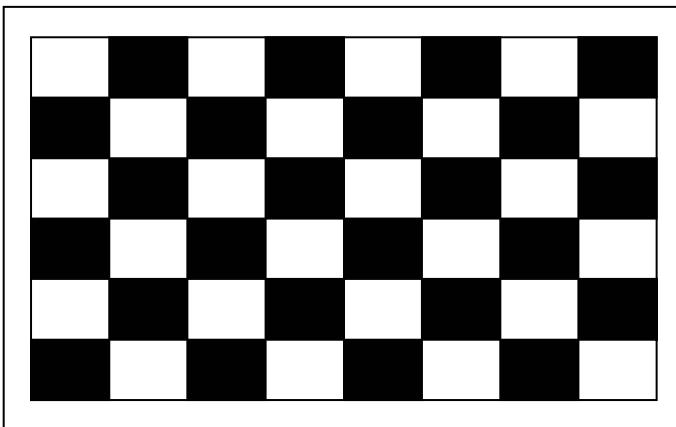

[Figure 3]
Mosaic pattern : for power consumption measurement

Product Specification

Table 3. INVERTER ELECTRICAL CHARACTERISTICS

Parameter	Symbol	Condition	Value			Unit	Note
			Min	Typ	Max		
2. Power for Inverter							
Power supply Input Voltage	V_{BL}		22.8	24.0	25.2	Vdc	
Power supply Input Current	I_{BL}	$V_{BR-B} = 3.3V$	TBD	TBD	TBD	A	
Power Consumption	P_{BL}	$V_{BR-B} = 3.3V$	-	55.2	64.8	Watt	
Back-Light ON/OFF Control voltage	ON/OFF	H (Lamp ON)	3.0	-	5.0	Vdc	
		L (Lamp OFF)	0.0	-	0.8	Vdc	
Analog Dimming Control	V_{BR-A}		0.0	-	3.3	Vdc	
Operating Frequency	F_o		60	-	70	KHz	
PWM Frequency	F_b		TBD	TBD	TBD	Hz	
Analog Dimming Ratio	V_{br-A}		TBD		100	%	
PWM Dimming Ratio	ExtVbr-B		20		100	%	
Lamp Voltage(Output)	V_{out}		TBD	TBD	TBD	V_{RMS}	
Lamp Current	$I_{o-max.}$		TBD	TBD	TBD	mA_{RMS}	
	$I_{o-typ.}$		TBD	TBD	TBD	mA_{RMS}	
	$I_{o-min.}$		TBD	TBD	TBD	mA_{RMS}	
Output Power			TBD	TBD	TBD	W	
Efficiency	η		TBD	-	-	%	
Lamp Lifetime	-		50,000		-	Hrs	

Notes :

- The specified current and power consumption are under the typical supply Input voltage, 24.0V.
The ripple voltage of the power supply input voltage is under 0.5 Vp-p.
Inrush current of the power supply input current is under +10% of the typical current
- Specified values are for a single lamp which is aligned horizontally.
- The life is determined as the time at which luminance of the lamp is 50% compared to that of initial value at the typical lamp current on condition of continuous operating at $25 \pm 2^\circ C$.
- Specified value is when lamp is aligned horizontally.
- Burst mode is controlled by TV system

Product Specification

3-2. Interface Connections

This LCD employs two kinds of interface connections. A 30 pin connector is used for LCD electronics and a 12pin connector is used for the integral backlight system.

3-2-1. Signal Interface

The LCD connector(CN1) : FI-X30SSL-HF (Manufactured by JAE) or Equivalent.
The pin configuration for the 30 pin connector is shown in the table below.

Table 4. 20Pin Connector pin configuration (For LCD Panel)

Pin	Signal assignment	Pin	Signal assignment
1	V _{LCD} (12V)	16	LVDS SIGNAL CHANNEL 1+
2	V _{LCD} (12V)	17	GND
3	V _{LCD} (12V)	18	LVDS SIGNAL CHANNEL 2-
4	V _{LCD} (12V)	19	LVDS SIGNAL CHANNEL 2+
5	GND	20	GND
6	GND	21	LVDS CLOCK C-
7	GND	22	LVDS CLOCK C+
8	GND	23	GND
9	DISM (Note 1)	24	LVDS SIGNAL CHANNEL 3-
10	NC	25	LVDS SIGNAL CHANNEL 3+
11	GND	26	GND
12	LVDS SIGNAL CHANNEL 0-	27	NC
13	LVDS SIGNAL CHANNEL 0+	28	NC
14	GND	29	GND
15	LVDS SIGNAL CHANNEL 1-	30	GND

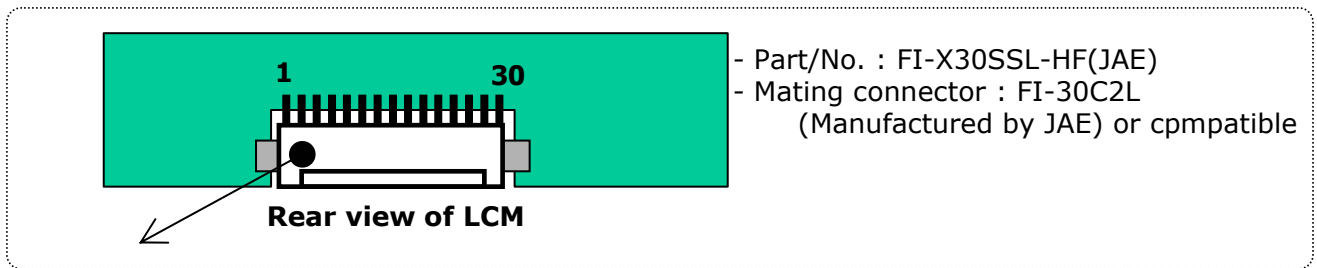

Notes:

1. If pin9 is ground, interface format is "LG", and if pin9 is 3.3V, interface format is "DISM". (See page 9~10)
2. All GND(ground) pins should be connected together and should also be connected to the LCD's metal frame.
3. All power input pins should be connected together.
4. Input level of LVDS signal is based on the IEA664 standard.
5. The pin30 should be ground, this pin is necessary for LPL's test

Product Specification

Table 5.
Required signal assignment for LVDS transmitter (Pin9 = "L" or open)

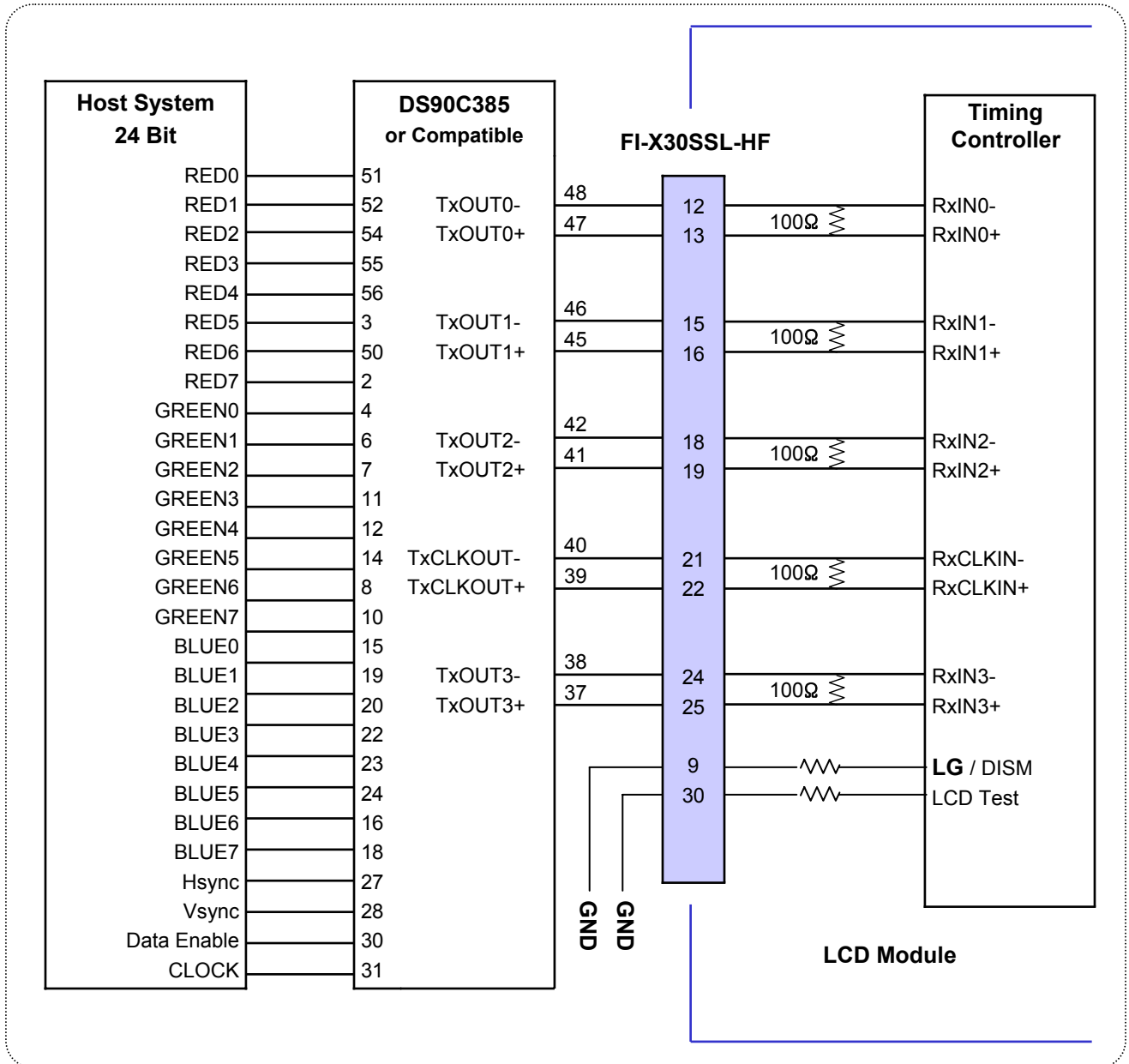

Note:

1. The LCD module uses a 100 Ohm(Ω) resistor between positive and negative lines of each receiver input.
2. Refer to LVDS transmitter data sheet for detail descriptions. (DS90C385 or Compatible)
3. '7' means MSB and '0' means LSB at R,G,B pixel data.

Product Specification

Table 6.
Required signal assignment for LVDS transmitter (Pin9 = "H")

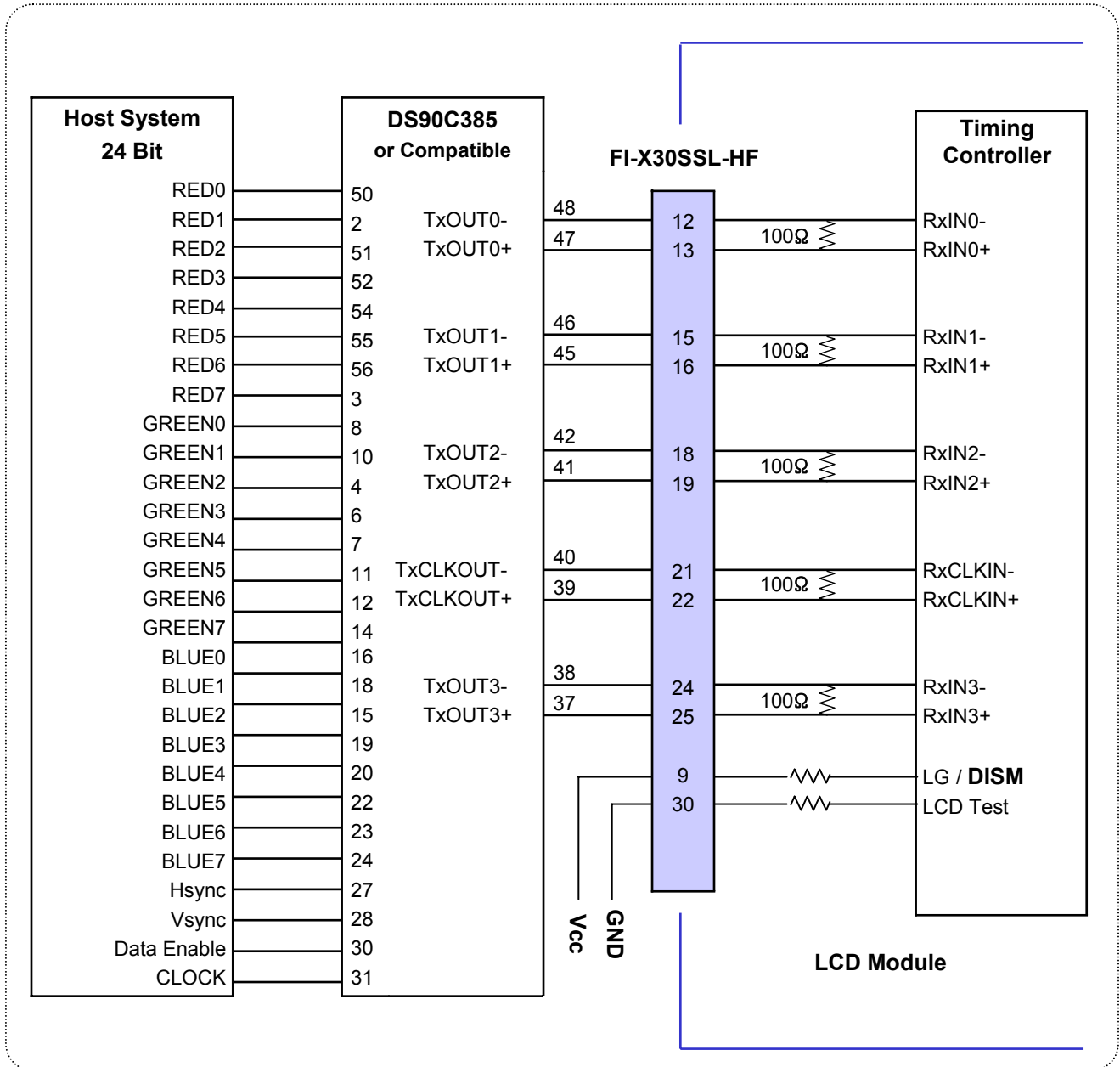

Note:

1. The LCD module uses a 100 Ohm(Ω) resistor between positive and negative lines of each receiver input.
2. Refer to LVDS transmitter data sheet for detail descriptions. (DS90C385 or Compatible)
3. '7' means MSB and '0' means LSB at R,G,B pixel data.

Product Specification

3-2-2. Inverter Connector for Backlight

The inverter connector is S14B-PH-SM3 side entry type (manufactured by JST) or equivalent
The pin configuration for the 14 pin connector is shown in the table below.

Table 7. 14Pin Connector Pin Configuration (For Inverter Connector)

Pin	Symbol	Signal assignment		Note
		Master(CN2)	Slave(CN3)	
1	VBL	24V Power Input	24V Power Input	
2	VBL	24V Power Input	24V Power Input	
3	VBL	24V Power Input	24V Power Input	
4	VBL	24V Power Input	24V Power Input	
5	VBL	24V Power Input	24V Power Input	
6	GND	GROUND	GROUND	
7	GND	GROUND	GROUND	
8	GND	GROUND	GROUND	1
9	GND	GROUND	GROUND	
10	GND	GROUND	GROUND	
11	V _{BR} -A	Analog dimming	Don't care	Open or High(3.3V) for Max. Lum.
12	ON / OFF	Backlight ON/OFF control	Don't care	On : Open or High
13	EXTV _{BR} -B	External PWM signal	Don't care	Open or High for Max. Lum.
14	GND	Signal Ground		

1. Connector

- 1) Connector(Receptacle)
: S14B-PH-SM3 (JST) or its equivalent
- 2) Mating Connector(Plug)
: PHR14 (JST) or its equivalent

* JST : Japan solderless Terminal Co.,Ltd.

Rear view of LCM

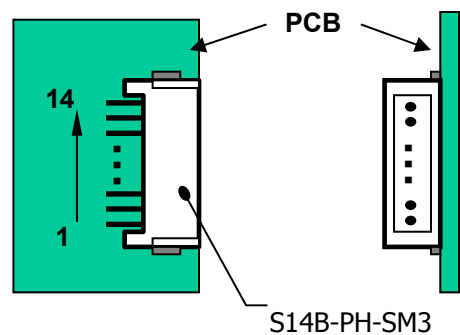

Notes : Pin 5~14 should connect to master and slave connector.

- 1. GROUND is connected to the LCD's metal frame.

Product Specification
3-3. Signal Timing Specifications

This is the signal timing required at the input of the LVDS transmitter. All of the interface signal timing should be satisfied with the following specifications for it's proper operation.

Table 8. Timing Table

ITEM		SYMBOL	Min.	Typ.	Max.	Unit	Note
Clock	Period	t_{CLK}	12.5	13.8	14.7	ns	
	Frequency	f_{CLK}	68	72.3	80	MHz	
Hsync	Horizontal total	t_{HT}	1416	1528	1776	Pixel	
	Hsync frequency	f_H	45.0	47.4	50	KHz	
	Hsync width	t_{WH}	8	32	-	Pixel	
Vsync	Vertical total	t_{VT}	775	790	1063	Line	
	Vsync frequency	f_V	47	60	63	Hz	
	Vsync width	t_{WV}	2	5	-	Line	
DE	Horizontal valid	t_{HV}	1366	1366	1366	Pixel	
	Horizontal back porch	t_{HBP}	24	80	-		
	Horizontal front porch	t_{HFP}	16	48	-		
	Horizontal blank	-	48	160	$t_{HP} - t_{HV}$		
	Vertical valid	t_{VV}	768	768	768	Line	
	Vertical back porch	t_{VBP}	4	15	-		
	Vertical front porch	t_{VFP}	1	2	-		
	Vertical blank	-	7	22	$t_{VP} - t_{VV}$		

Note:

Hsync period and Hsync width-active should be even number times of t_{CLK} . If the value is odd number times of t_{CLK} , display control signal can be asynchronous.

In order to operate this LCM a Hsync., Vsync and DE(data enable) signals should be used.

1. The performance of the electro-optical characteristics are may be influenced by variance of the vertical refresh rates.
2. Vsync, Hsync should be keep the above specification.

Product Specification

3-4. Signal Timing Waveforms

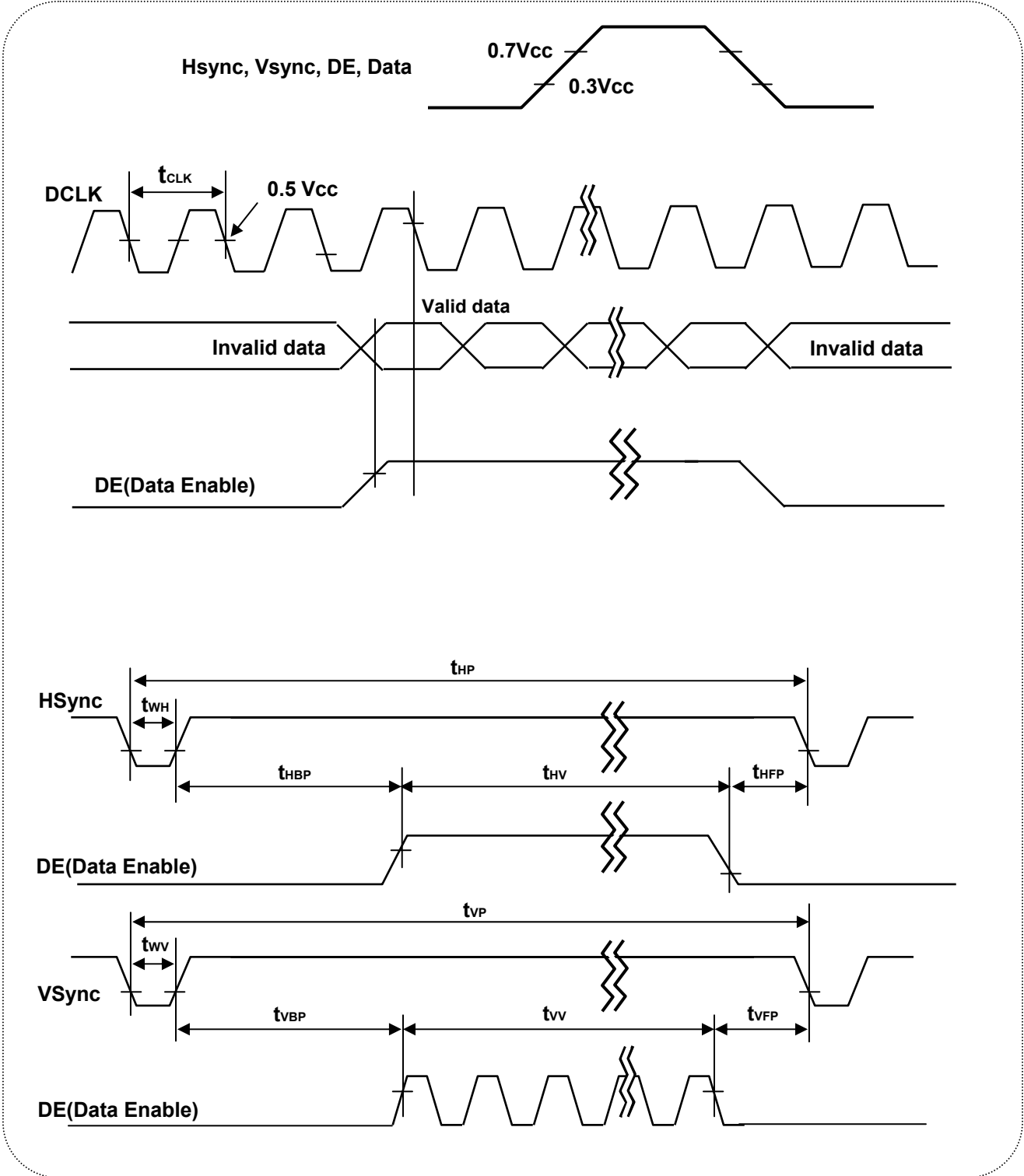

Product Specification

3-5. Color Input Data Reference

The brightness of each primary color (red, green and blue) is based on the 8-bit gray scale data input for the color ; the higher the binary input, the brighter the color.
The table below provides a reference for color versus data input.

Table 9. Color Data Reference

Color		Input Color Data																							
		Red								Green								Blue							
		MSB				LSB				MSB				LSB				MSB				LSB			
		R7	R6	R5	R4	R3	R2	R1	R0	G7	G6	G5	G4	G3	G2	G1	G0	B7	B6	B5	B4	B3	B2	B1	B0
Basic Color	Black	0	0	0	0	0	0	0	0	0	0	0	0	0	0	0	0	0	0	0	0	0	0	0	0
	Red (255)	1	1	1	1	1	1	1	1	0	0	0	0	0	0	0	0	0	0	0	0	0	0	0	0
	Green (255)	0	0	0	0	0	0	0	0	1	1	1	1	1	1	1	1	0	0	0	0	0	0	0	0
	Blue (255)	0	0	0	0	0	0	0	0	0	0	0	0	0	0	0	0	1	1	1	1	1	1	1	1
	Cyan	0	0	0	0	0	0	0	0	1	1	1	1	1	1	1	1	1	1	1	1	1	1	1	1
	Magenta	1	1	1	1	1	1	1	1	0	0	0	0	0	0	0	0	1	1	1	1	1	1	1	1
	Yellow	1	1	1	1	1	1	1	1	1	1	1	1	1	1	1	1	0	0	0	0	0	0	0	0
	White	1	1	1	1	1	1	1	1	1	1	1	1	1	1	1	1	1	1	1	1	1	1	1	1
Red	Red(000) Dark	0	0	0	0	0	0	0	0	0	0	0	0	0	0	0	0	0	0	0	0	0	0	0	0
	Red(001)	0	0	0	0	0	0	0	1	0	0	0	0	0	0	0	0	0	0	0	0	0	0	0	0
	Red(002)	0	0	0	0	0	0	1	0	0	0	0	0	0	0	0	0	0	0	0	0	0	0	0	0
	-----	-	-	-	-	-	-	-	-	-	-	-	-	-	-	-	-	-	-	-	-	-	-	-	-
	-----	-	-	-	-	-	-	-	-	-	-	-	-	-	-	-	-	-	-	-	-	-	-	-	-
	Red(253)	1	1	1	1	1	1	0	1	0	0	0	0	0	0	0	0	0	0	0	0	0	0	0	0
	Red(254)	1	1	1	1	1	1	1	0	0	0	0	0	0	0	0	0	0	0	0	0	0	0	0	0
	Red(255) Bright	1	1	1	1	1	1	1	1	0	0	0	0	0	0	0	0	0	0	0	0	0	0	0	0
Green	Green(000) Dark	0	0	0	0	0	0	0	0	0	0	0	0	0	0	0	0	0	0	0	0	0	0	0	0
	Green(001)	0	0	0	0	0	0	0	0	0	0	0	0	0	0	1	0	0	0	0	0	0	0	0	0
	Green(002)	0	0	0	0	0	0	0	0	0	0	0	0	0	1	0	0	0	0	0	0	0	0	0	0
	-----	-	-	-	-	-	-	-	-	-	-	-	-	-	-	-	-	-	-	-	-	-	-	-	-
	-----	-	-	-	-	-	-	-	-	-	-	-	-	-	-	-	-	-	-	-	-	-	-	-	-
	Green(253)	0	0	0	0	0	0	0	0	1	1	1	1	1	1	0	1	0	0	0	0	0	0	0	0
	Green(254)	0	0	0	0	0	0	0	0	1	1	1	1	1	1	1	0	0	0	0	0	0	0	0	0
	Green(255) Bright	0	0	0	0	0	0	0	0	1	1	1	1	1	1	1	1	0	0	0	0	0	0	0	0
Blue	Blue(000) Dark	0	0	0	0	0	0	0	0	0	0	0	0	0	0	0	0	0	0	0	0	0	0	0	0
	Blue(001)	0	0	0	0	0	0	0	0	0	0	0	0	0	0	0	0	0	0	0	0	0	0	0	1
	Blue(002)	0	0	0	0	0	0	0	0	0	0	0	0	0	0	0	0	0	0	0	0	0	0	1	0
	-----	-	-	-	-	-	-	-	-	-	-	-	-	-	-	-	-	-	-	-	-	-	-	-	-
	-----	-	-	-	-	-	-	-	-	-	-	-	-	-	-	-	-	-	-	-	-	-	-	-	-
	Blue(253)	0	0	0	0	0	0	0	0	0	0	0	0	0	0	0	1	1	1	1	1	1	1	0	1
	Blue(254)	0	0	0	0	0	0	0	0	0	0	0	0	0	0	0	1	1	1	1	1	1	1	1	0
	Blue(255) Bright	0	0	0	0	0	0	0	0	0	0	0	0	0	0	0	1	1	1	1	1	1	1	1	1

Product Specification

3-6. Power Sequence

3-6-1. Sequence for LCD Module

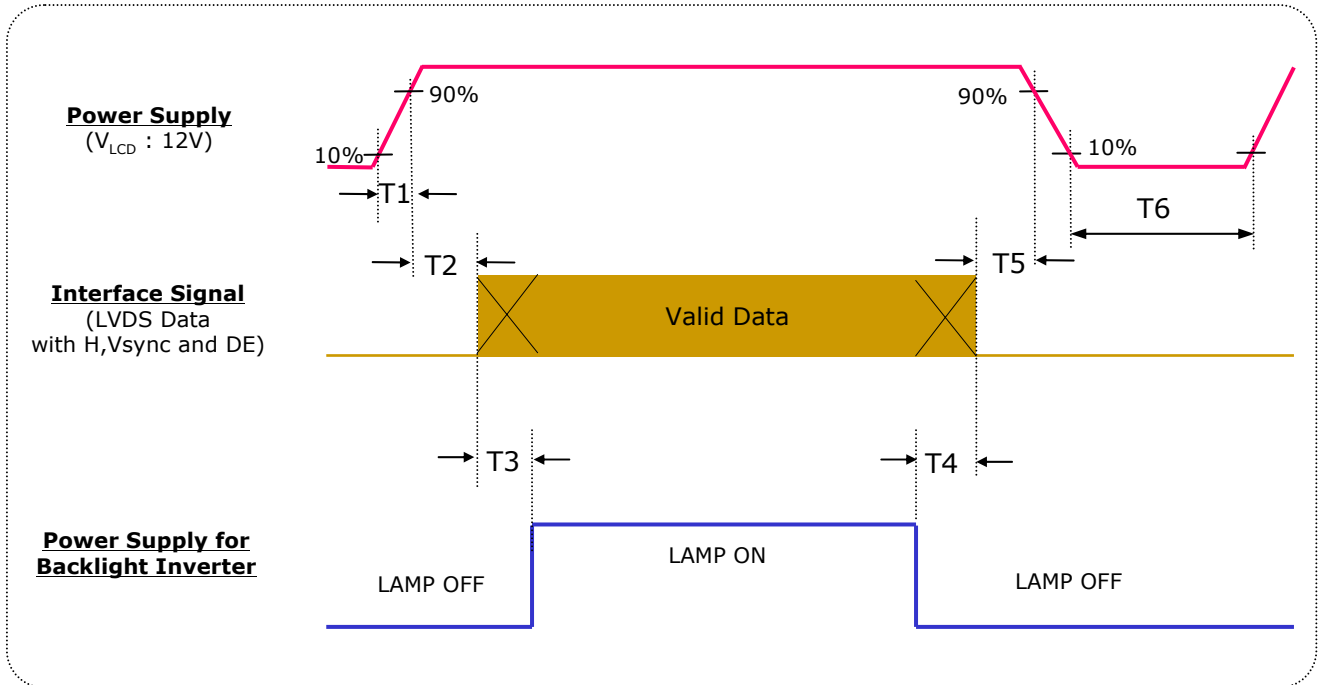

Table 10. Power Sequence for LCM

Parameter	Value			Unit
	Min	Typ	Max	
T1	0.01	-	10	ms
T2	0.01	-	50	ms
T3	200	-	-	ms
T4	200	-	-	ms
T5	0.01	-	50	ms
T6	2000	-	-	ms

Notes :

1. Please avoid floating state of interface signal at invalid period.
2. When the interface signal is invalid, be sure to pull down the power supply for LCD V_{LCD} to 0V.
3. Lamp power must be turn on after power supply for a LCD interface signal are valid.
4. T6 should be measured after the module has been fully discharged between power off and on period.

Product Specification

3-6-2. Sequence for Inverter

Power Supply For Inverter
($V_{BL} : 24V$)

On/Off Control
($0 \sim 5V$)

Brightness Adj.
 $V_{BR-A} : (0 \sim 3.3V)$

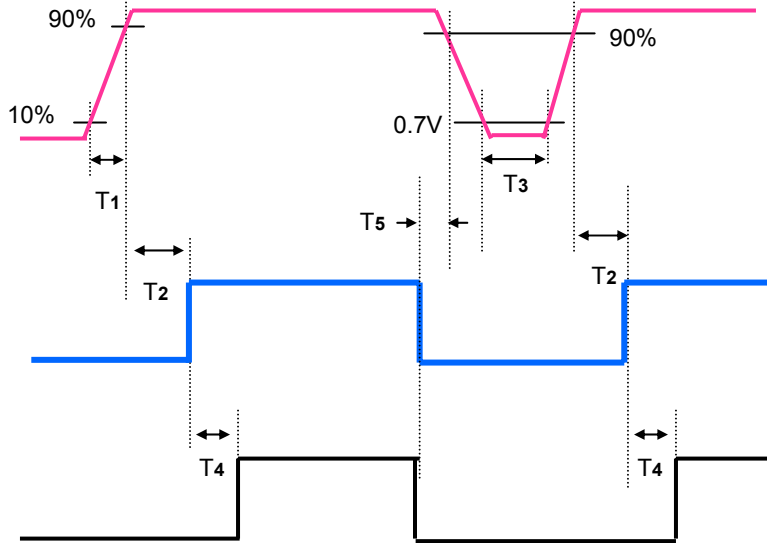

- EXTV_{BR-B} : 1. Lamp ON at PWM Low and Lamp OFF at PWM High
- 2. EXTVBR-B has same sequence with V_{BR-A}

3-6-3. Deep condition for Inverter

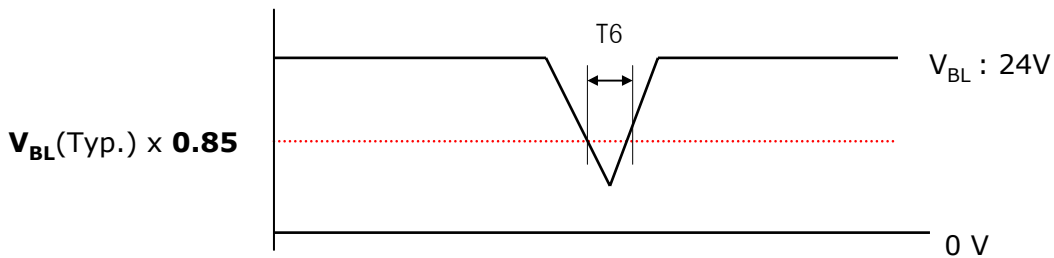

Table 11. Power Sequence for Inverter

Parameter	Value			Unit	Note
	Min	Typ	Max		
T1	20	-	-	ms	1
T2	100	-	-	ms	
T3	200	-	-	ms	2
T4	0	-	-	ms	
T5	10	-	-	ms	
T6	-	-	10	ms	$V_{BL}(Typ) \times 0.85$

- Note :
- 1. T1 describes rising time of 0V to 24V and is not applied at restarting time.
 - 2. When the inverter is shut-down by ARC protection, T3 needs 3.3sec.
 - 3. When V_{BL} (24V) is supplied always, there is no reliability problem.

Product Specification
4. Optical Specification

Optical characteristics are determined after the unit has been 'ON' for 30Min in a dark environment at $25\pm 2^{\circ}\text{C}$. The values specified are at an approximate distance 50cm from the LCD surface at a viewing angle of ϕ and θ equal to 0° .

FIG. 4 presents additional information concerning the measurement equipment and method.

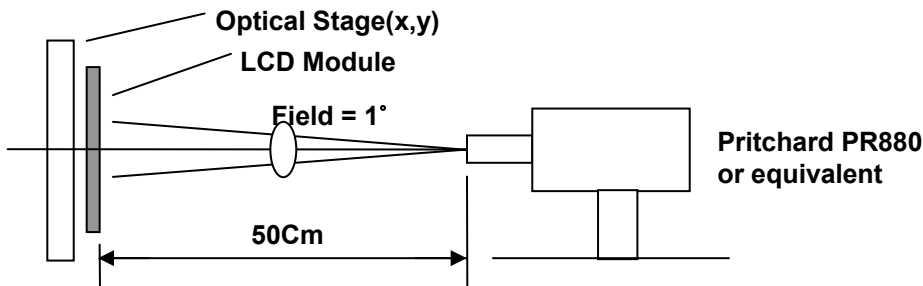

[Figure 4] Optical characteristic measurement equipment and method

Table 12. Optical characteristics

($T_a=25\pm 2^{\circ}\text{C}$, $V_{\text{LCD}}=12\text{V}$, $f_V=60\text{Hz}$, $\text{CLK}=72.3\text{MHz}$, $V_{\text{BR-A}}=\text{TBD}$, $\text{EXTV}_{\text{BR-B}}=\text{H}$)

Parameter	Symbol	Value			Unit	Note
		Min	Typ	Max		
Contrast Ratio	CR	450	600			1
Surface Luminance, white	L_{WH}	350	500		cd/m ²	2
Luminance Variation	δ_{WHITE}		-	1.3		3
Response Time	Rise Time		7.5	15	ms	4
	Decay Time		8.5	15		
Color Coordinates						
RED	RX	Typ -0.03	TBD	Typ +0.03		
	RY		TBD			
GREEN	GX		TBD			
	GY		TBD			
BLUE	BX		TBD			
	BY		TBD			
WHITE	WX		TBD			
	WY		TBD			
Viewing Angle (CR>10)						
x axis, right($\phi=0^{\circ}$)	θ_r	85	89	-	degree	5
x axis, left ($\phi=180^{\circ}$)	θ_l	85	89	-		
y axis, up ($\phi=90^{\circ}$)	θ_u	85	89	-		
y axis, down ($\phi=270^{\circ}$)	θ_d	85	89	-		
Gray scale			2.2			6

Product Specification

Note :

1. Contrast ratio(CR) is defined mathematically as :

$$\text{Contrast ratio} = \frac{\text{Surface luminance with all white pixels}}{\text{Surface luminance with all black pixels}}$$

It is measured at center point(1)

2. Surface luminance(L_{WH}) is luminance value at center point (P1) across the LCD surface 50cm from the surface with all pixels displaying white.
For more information see FIG 5.

3. The variation in surface luminance , δ_{WHITE} is defined as

$$\delta_{WHITE} = \text{Maximum (P1,P2,P5)} / \text{Minimum (P1,P2,P5)}$$

For more information see [Figure 5].

<Measuring point for surface luminance and luminance variation>

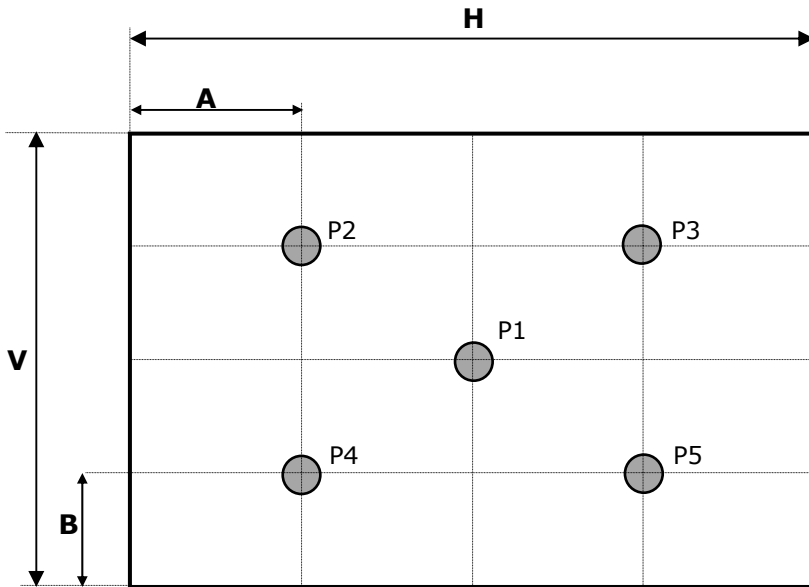

A : H / 4 mm
 B : V / 4 mm
 H : 575.769 mm
 V : 323.712 mm
 @ H,V : Active Area

Figure 5. Luminance measuring point

Product Specification

4. The response time is defined as the following figure and shall be measured by switching the input signal for each gray to gray.

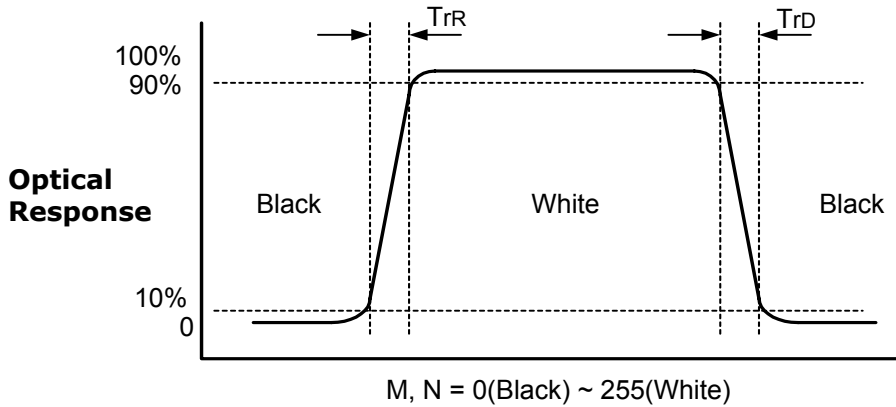

Figure 6. Response time

5. Viewing angle is the angle at which the contrast ratio is greater than 10. The angles are determined for the horizontal or x axis and the vertical or y axis with respect to the z axis which is normal to the LCD surface. For more information see Figure 7 .

<Dimension of viewing angle range>

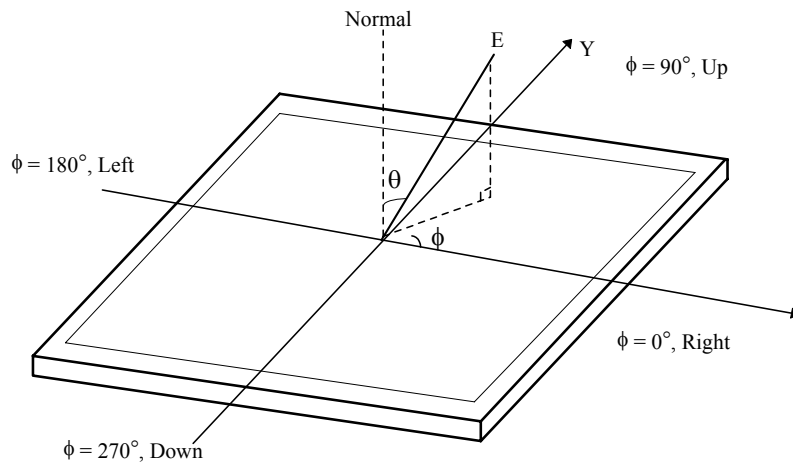

Figure 7. Viewing angle

Product Specification

6. Gray scale specification

Table 13. Gray scale

Gray Level	Luminance [%] (Typ)
L0	TBD
L15	TBD
L31	TBD
L47	TBD
L63	TBD
L79	TBD
L95	TBD
L111	TBD
L127	TBD
L143	TBD
L159	TBD
L175	TBD
L191	TBD
L207	TBD
L223	TBD
L239	TBD
L255	TBD

Product Specification

5. Mechanical Characteristics

Table 11. provides general mechanical characteristics for the model LC260WX2. In addition, the figures in the next page are detailed mechanical drawing of the LCD.

Table 14. Mechanical characteristics

Outline Dimension	Horizontal	626.0 mm
	Vertical	373.0 mm
	Depth	44.1 mm
Bezel Area	Horizontal	580.8 mm
	Vertical	328.8 mm
Active Display Area	Horizontal	575.769 mm
	Vertical	323.712 mm
Weight	5000 g (Typ.), 5200 g (Max.)	
Surface Treatment	Hard coating(3H) Anti-glare treatment of the front polarizer	

Notes : Please refer to a mechanic drawing in terms of tolerance at the next page.

Product Specification

<FRONT VIEW>

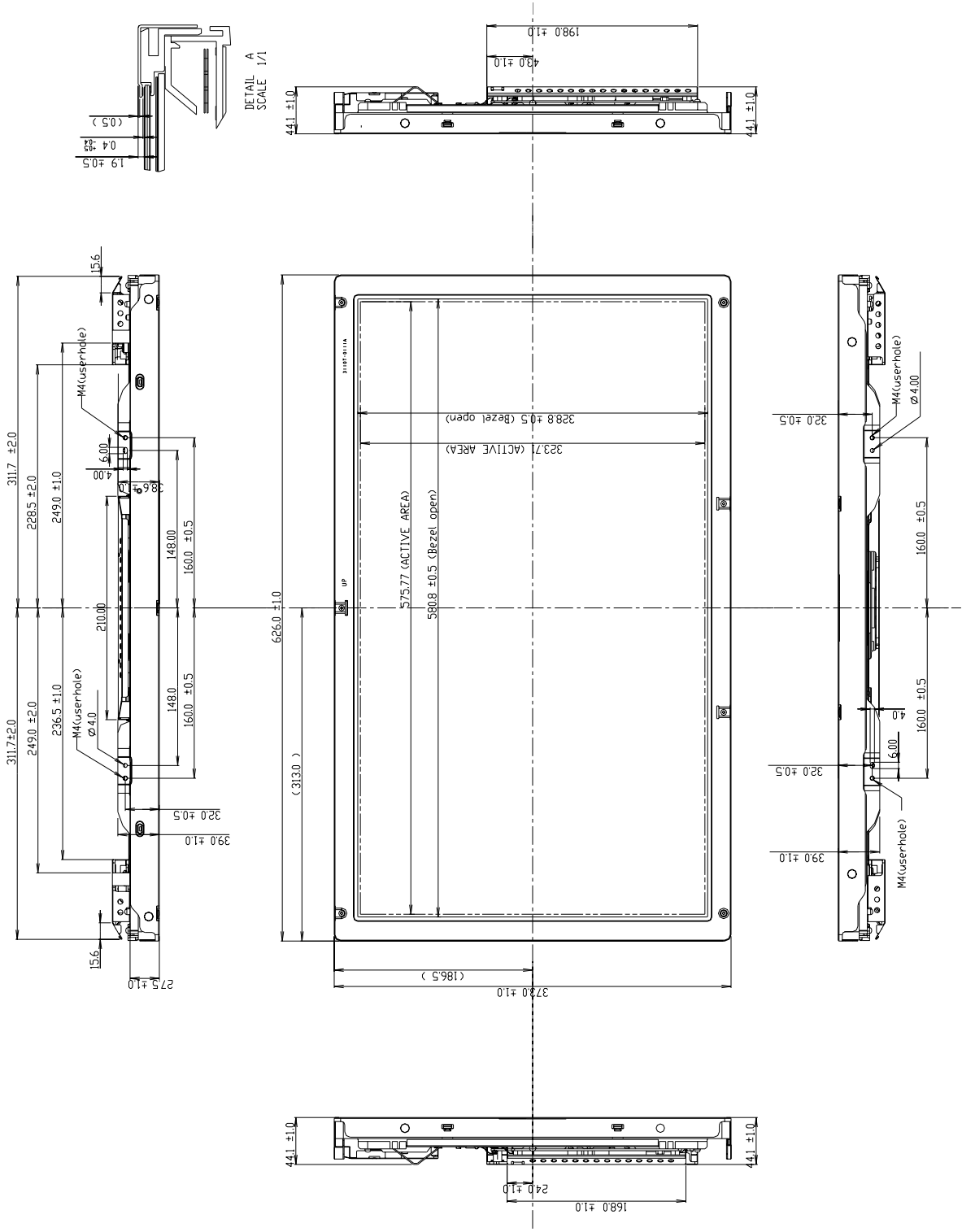

Product Specification

<REAR VIEW>

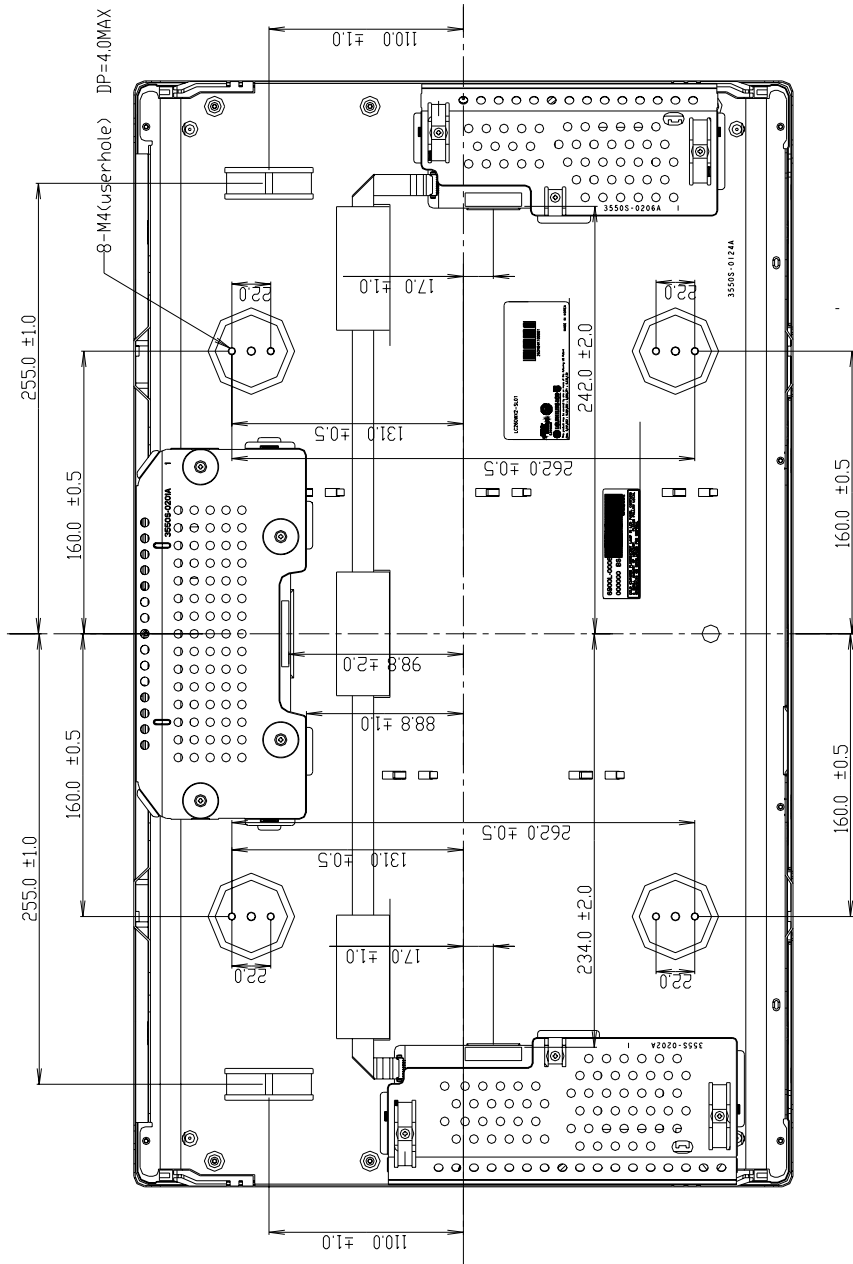

- NOTES
1. UNSPECIFIED TOLERANCES ARE $\pm 0.5\text{mm}$
 2. TILT AND A PARTIAL DISPOSITION TOLERANCE OF DISPLAY AREA ARE AS FOLLOW
 - 1) X-DIRECTION : |A-B| < 1.7mm
 - 2) Y-DIRECTION : |C-D| < 1.7mm

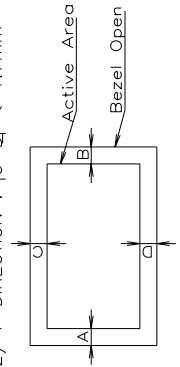

Product Specification

6. Reliability

Environment test condition

No	Test Item	Condition
1	High temperature storage test	50°C, 240hrs
2	Low temperature storage test	-20°C, 240hrs
3	High temperature operation test	40°C, 50%RH, 240hrs
4	Low temperature operation test	0°C, 240hrs
5	Vibration test (non-operating)	Wave form : random Vibration level : 1.0Grms Bandwidth : 10-500Hz Duration : X,Y,Z, 10 min One time each direction
6	Shock test (non-operating)	Shock level : 100Grms Waveform : half sine wave, 2ms Direction : ±X, ±Y, ±Z One time each direction
7	Humidity condition Operation	Ta= 40 °C ,90%RH
8	Altitude operating storage / shipment	0 - 14,000 feet(4267.2m) 0 - 40,000 feet(12192m)

Product Specification**7. International Standards****7-1. Safety**

- a) UL 60950, Third Edition, Underwriters Laboratories, Inc., Dated Dec. 11, 2000.
Standard for Safety of Information Technology Equipment, Including Electrical Business Equipment.
- b) CAN/CSA C22.2, No. 60950, Third Edition, Canadian Standards Association, Dec. 1, 2000.
Standard for Safety of Information Technology Equipment, Including Electrical Business Equipment.
- c) EN 60950 : 2000, Third Edition
IEC 60950 : 1999, Third Edition
European Committee for Electrotechnical Standardization(CENELEC)
EUROPEAN STANDARD for Safety of Information Technology Equipment Including
Electrical Business Equipment.

7-2. EMC

- a) ANSI C63.4 "Methods of Measurement of Radio-Noise Emissions from Low-Voltage Electrical and Electrical Equipment in the Range of 9kHz to 40GHz. "American National Standards Institute(ANSI),1992
- b) C.I.S.P.R "Limits and Methods of Measurement of Radio Interface Characteristics of Information Technology Equipment." International Special Committee on Radio Interference.
- c) EN 55022 "Limits and Methods of Measurement of Radio Interface Characteristics of Information Technology Equipment." European Committee for Electrotechnical Standardization.(CENELEC), 1998(Including A1: 2000)

Product Specification

8. Packing

8-1. Designation of Lot Mark

A	B	C	D	E	F	G	H	I	J	K	L	M
---	---	---	---	---	---	---	---	---	---	---	---	---

A,B,C : SIZE(INCH)

E : MONTH

G : ASSEMBLY CODE

D : YEAR

F : FACTORY CODE

H ~ M : SERIAL NO.

Note

1. YEAR

Year	2001	2002	2003	2004	2005	2006	2007	2008	2009	2010
Mark	1	2	3	4	5	6	7	8	9	0

2. MONTH

Month	Jan	Feb	Mar	Apr	May	Jun	Jul	Aug	Sep	Oct	Nov	Dec
Mark	1	2	3	4	5	6	7	8	9	A	B	C

3. FACTORY CODE

Factory Code	LPL Gumi	LPL Nanjing	HEESUNG
Mark	K	C	D

4. SERIAL NO.

Mark	100001~199999, 200001~299999, 300001~399999,, A00001~A99999,, Z00001~Z99999
------	---

b) Location of Lot Mark

Serial No. is printed on the label. The label is attached to the backside of the LCD module.
 This is subject to change without prior notice.

8-2. Packing Form

- a) Package quantity in one box : 6 pcs
- b) Box size : 737mm X 491mm X 472mm.

Product Specification

9. Precautions

Please pay attention to the following when you use this TFT LCD module.

9-1. Mounting Precautions

- (1) You must mount a module using holes arranged in rear and side.
- (2) You should consider the mounting structure so that uneven force(ex. twisted stress) is not applied to the module. And the case on which a module is mounted should have sufficient strength so that external force is not transmitted directly to the module.
- (3) Please attach a transparent protective plate to the surface in order to protect the polarizer. Transparent protective plate should have sufficient strength in order to resist external force.
- (4) You should adopt radiation structure to satisfy the temperature specification.
- (5) Acetic acid type and chlorine type materials for the cover case are not describe because the former generates corrosive gas of attacking the polarizer at high temperature and the latter causes circuit break by electro-chemical reaction.
- (6) Do not touch, push or rub the exposed polarizers with glass, tweezers or anything harder than HB pencil lead. And please do not rub with dust clothes with chemical treatment. Do not touch the surface of polarizer with bare hand or greasy cloth.
(Some cosmetics are determined to the polarizer.)
- (7) When the surface becomes dusty, please wipe gently with absorbent cotton or other soft materials like chamois soaks with petroleum benzine. Normal-hexane is recommended for cleaning the adhesives used to attach front / rear polarizers. Do not use acetone, toluene and alcohol because they cause chemical damage to the polarizer.
- (8) Wipe off saliva or water drops as soon as possible. Their long time contact with polarizer causes deformations and color fading.
- (9) Do not open the case because inside circuits do not have sufficient strength.

9-2. Operating Precautions

- (1) The spike noise causes the mis-operation of circuits. It should be lower than following voltage : $V = \pm 200\text{mV}$ (Over and under shoot voltage)
- (2) Response time depends on the temperature.(In lower temperature, it becomes longer.)
- (3) Brightness depends on the temperature. (In lower temperature, it becomes lower.)
And in lower temperature, response time(required time that brightness is stable after turned on)becomes longer.
- (4) Be careful for condensation at sudden temperature change. Condensation makes damage to polarizer or electrical contacted parts. And after fading condensation, smear or spot will occur.
- (5) When fixed patterns are displayed for a long time, remnant image is likely to occur.
- (6) Module has high frequency circuits. Sufficient suppression to the electromagnetic interference shall be done by system manufacturers. Grounding and shielding methods may be important to minimized the interference.
- (7) Please do not give any mechanical and/or acoustical impact to LCM. Otherwise, LCM can not be operated its full characteristics perfectly.
- (8) A screw which is fastened up the steels should be a machine screw
(if not, it causes metal foreign material and deals LCM a fatal blow)
- (9) Please do not set LCD on its edge.

Product Specification

9-3. Electrostatic Discharge Control

Since a module is composed of electronic circuits, it is not strong to electrostatic discharge. Make certain that treatment persons are connected to ground through wrist band etc. And don't touch interface pin directly.

9-4. Precautions for Strong Light Exposure

Strong light exposure causes degradation of polarizer and color filter.

9-5. Storage

When storing modules as spares for a long time, the following precautions are necessary.

- (1) Store them in a dark place. Do not expose the module to sunlight or fluorescent light. Keep the temperature between 5°C and 35°C at normal humidity.
- (2) The polarizer surface should not come in contact with any other object.
It is recommended that they be stored in the container in which they were shipped.

9-6. Handling Precautions for Protection Film

- (1) The protection film is attached to the bezel with a small masking tape.
When the protection film is peeled off, static electricity is generated between the film and polarizer.
This should be peeled off slowly and carefully by people who are electrically grounded and with well ion-blown equipment or in such a condition, etc.
- (2) When the module with protection film attached is stored for a long time, sometimes there remains a very small amount of glue still on the Bezel after the protection film is peeled off.
- (3) You can remove the glue easily. When the glue remains on the Bezel or its vestige is recognized,
please wipe them off with absorbent cotton waste or other soft material like chamois soaked with normal-hexane.