

SPECIFICATION FOR APPROVAL

- (◆) Preliminary Specification
 () Final Specification

Title	12.1" SVGA TFT LCD
-------	--------------------

Customer	
MODEL	

SUPPLIER	LG Display Co., Ltd.
*MODEL	LB121S03
Suffix	TL03

*When you obtain standard approval,
 please use the above model name without suffix

APPROVED BY	SIGNATURE
/	_____
/	_____
/	_____

Please return 1 copy for your confirmation with your signature and comments.

APPROVED BY	SIGNATURE
_____	_____
REVIEWED BY	
_____	_____
PREPARED BY	
_____	_____

**Products Engineering Dept.
 LG Display Co., Ltd**

Product Specification

Contents

No	ITEM	Page
	COVER	1
	CONTENTS	2
	RECORD OF REVISIONS	3
1	GENERAL DESCRIPTION	4
2	ABSOLUTE MAXIMUM RATINGS	5
3	ELECTRICAL SPECIFICATIONS	
3-1	ELECTRICAL CHARACTERISTICS	6
3-2	INTERFACE CONNECTIONS	8
3-3	CONNECTION BETWEEN HOST SYSTEM AND LCD MODULE	9
3-4	LVDS SIGNAL TIMING SPECIFICATIONS	12
3-5	SIGNAL TIMING SPECIFICATION	14
3-6	COLOR INPUT DATA REFERNECE	15
3-7	POWER SEQUENCE	18
4	OPTICAL SPECIFICATIONS	20
5	MECHANICAL CHARACTERISTICS	24
6	RELIABILITY	26
7	INTERNATIONAL STANDARDS	
7-1	SAFETY	28
7-2	Environmental	28
7-3	EMC	28
8	PACKING	
8-1	DESIGNATION OF LOT MARK	29
8-2	PACKING FORM	29
9	PRECAUTIONS	30

Product Specification
1. General Description

The LB121S03-TL03 is a Color Active Matrix Liquid Crystal Display with an integral LED backlight system. The matrix employs a-Si Thin Film Transistor as the active element. It is a transmissive type display operating in the normally white mode. This TFT-LCD has 12.1 inches diagonally measured active display area with SVGA resolution(800 horizontal by 600 vertical pixel array). Each pixel is divided into Red, Green and Blue sub-pixels or dots which are arranged in vertical stripes. Gray scale or the brightness of the sub-pixel color is determined with a 8-bit(or 6-bit) gray scale signal for each dot, thus, presenting a palette of more than 16,777,216(or 262,144) colors.

The LB121S03-TL03 has been designed to apply the interface method that enables low power, high speed, low EMI.

The LB121S03-TL03 is intended to support applications where thin thickness, low power are critical factors and graphic displays are important. In combination with the vertical arrangement of the sub-pixels, the LB121S03-TL03 characteristics provide an excellent flat display for office automation products such as PC or etc.

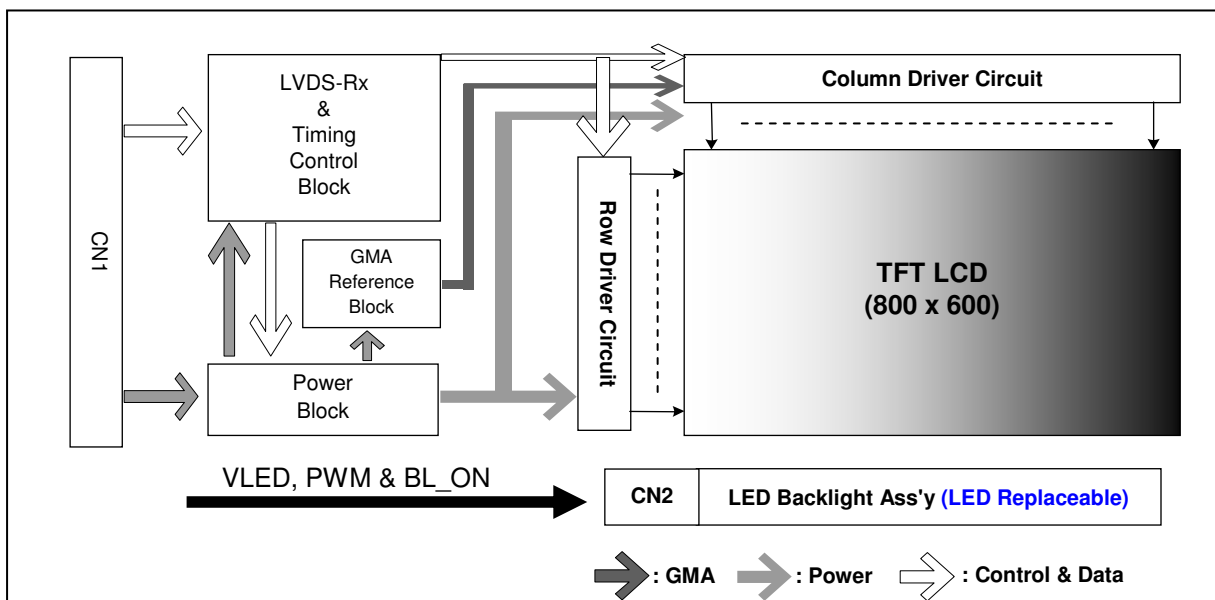
General Features

Active Screen Size	12.1 inches(30.75cm) diagonal
Outline Dimension	276(H) × 209(V) × 9(D) mm (Typ.)
Pixel Pitch	0.3075 mm × 0.3075 mm
Pixel Format	800 horiz. By 600 vert. Pixels RGB strip arrangement
Color Depth	16,777,216 colors(At 8-bit input) 262,144 colors(At 6-bit input)
Luminance, White	450 cd/m ² (Typ.)
Power Consumption	Total 5.73 Watt(Typ.) @ LCM circuit 0.69 Watt(Typ.), B/L input 5.04 Watt(Typ.)
Weight	530g (Max.)
Display Operating Mode	Transmissive mode, normally white
Surface Treatment	Anti-glare
RoHS Comply	Yes

2. Absolute Maximum Ratings

The following are maximum values which, if exceeded, may cause faulty operation or damage to the unit.

Table 1. ABSOLUTE MAXIMUM RATINGS

Parameter	Symbol	Values		Units	Notes
		Min	Max		
Power Input Voltage	VCC	-0.3	4.0	Vdc	at 25 ± 5°C
Operating Temperature	TOP	-20	70	°C	1
Storage Temperature	TST	-30	80	°C	1
Operating Ambient Humidity	HOP	10	90	%RH	1
Storage Humidity	HST	10	90	%RH	1

Note : 1. Temperature and relative humidity range are shown in the figure below.
 Wet bulb temperature should be 58°C Max, and no condensation of water.

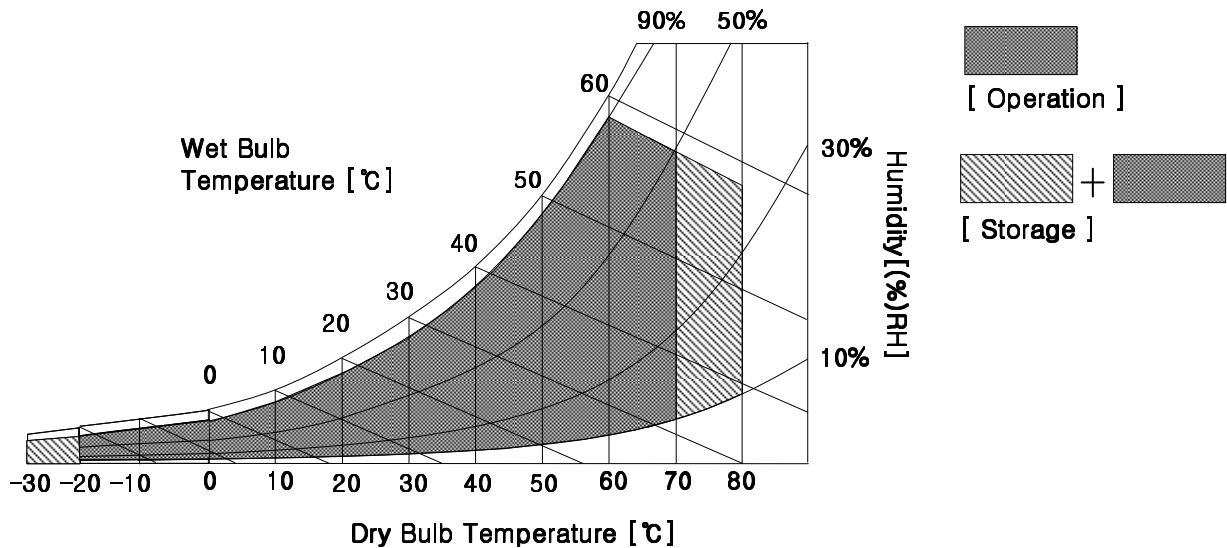

Product Specification

3. Electrical Specifications

3-1. Electrical Characteristics

The LB121S03-TL03 requires two power inputs. One is employed to power the LCD electronics and to drive the TFT array and liquid crystal. The second input which powers the LED BL.

Table 2. ELECTRICAL CHARACTERISTICS

Parameter	Symbol	Values			Unit	Notes
		Min	Typ	Max		
MODULE :						
Power Supply Input Voltage	VCC	3.0	3.3	3.6	V _{DC}	
Power Supply Input Current	I _{CC}	-	210	270	mA	1
Power Consumption	P _c	-	0.69	0.89	Watt	1
LED Backlight (With LED Driver) :						
LED Power Input Voltage	V _{LED}	10.8	12	12.6	V	2
LED Power Input Current	I _{LED}	-	0.42	0.48	mA	3
LED Power Consumption	P _{LED}	-	5.04	5.76	Watt	3
PWM Duty Ratio		10		100	%	4
PWM Frequency	F _{PWM}		120		Hz	5
PWM High Level Voltage	V _{PWM_H}	3	3.3	5		
PWM Low Level Voltage	V _{PWM_L}	0		0.5		
LED_EN High Voltage	V _{LED_EN_H}	3	3.3	5		
LED_EN Low Voltage	V _{LED_EN_L}	0		0.5		
Life Time		50,000	-	-	Hrs	6

Note)

- The specified current and power consumption are under the V_{cc} = 3.3V , 25°C , f_v = 60Hz condition whereas Mosaic pattern is displayed and f_v is the frame frequency.

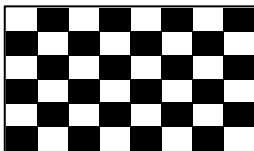

- The measuring position is the connector of LCM and the test conditions are under 25°C.
- The current and power consumption with LED Driver are under the V_{LED} = 12.0V , 25°C , Dimming of Max luminance whereas White pattern is displayed and f_v is the frame frequency.
- The operation of LED Driver below minimum dimming ratio may cause flickering or reliability issue.
- This Spec. is not effective at 100% dimming ratio as an exception because it has DC level equivalent to 0Hz. In spite of acceptable range as defined, the PWM Frequency should be fixed and stable for more consistent brightness control at any specific level desired.
- The life time is determined as the time at which brightness of LED is 50% compare to that of initial value at the typical LED current.

Product Specification

3-2. Interface Connections

This LCD employs two interface connections, a 20 pin connector is used for the module electronics interface and the other connector is used for the integral backlight system.

The electronics interface connector is a model FI-SEB20P-HFE manufactured by JAE.

Table 3. MODULE CONNECTOR PIN CONFIGURATION (CN1)

Pin	Symbol	Description	Notes
1	VCC	Power Supply, 3.3V Typ.	1. Interface chips 1.1 LCD : THine, KE5M6U2730WFP(LCD Controller) including LVDS Receiver
2	VCC	Power Supply, 3.3V Typ.	
3	Bit_SEL	Bit Selection, High(3.3V)/NC : 8 Bit, Low : 6 Bit	1.2 System : THC63LVDM83R or Equivalent
4	GND	Ground	
5	A1M	Negative LVDS differential data input	2. Connector 2.1 LCD : GT100-20P-LS-SMT, LS Cable or Equivalent
6	A1P	Positive LVDS differential data input	
7	GND	Ground	2.2 Mating : Discrete Wire type:DF19G-20S-1C(HIROSE) FPC type :DF19G-20S-1F(HIROSE)
8	A2M	Negative LVDS differential data input	
9	A2P	Positive LVDS differential data input	
10	GND	Ground	
11	A3M	Negative LVDS differential data input	
12	A3P	Positive LVDS differential data input	
13	GND	Ground	
14	CLKM	Negative LVDS differential clock input	
15	CLKP	Positive LVDS differential clock input	
16	GND	GND	
17	A4M	Negative LVDS differential data input(for 8 bit)	
18	A4P	Positive LVDS differential data input(for 8 bit)	
19	NC	Reserved For LGD	
20	NC	Reserved For LGD	

Rear view of LCM

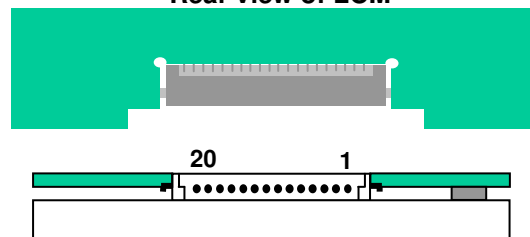

Product Specification

The LED backlight interface connectors are model FI-SEB20P-HFE, manufactured by JAE or Compatible.

The mating connector part number is :FI-SE20S or equivalent.

Table 4. LED BACKLIGHT CONNECTOR PIN CONFIGURATION (CN2)

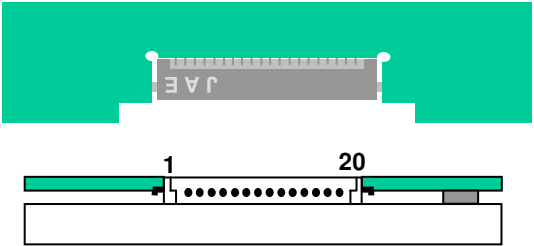
Pin	Symbol	Description	Notes
1	VLED	Power Supply, 12V Typ.	<p style="text-align: center;">Rear view of LCM</p>  <p>1. Connector 1.1 LCD : FI-SEB20P-HFE, JAE or Equivalent 1.2 Mating: Discrete Wire type: :FI-SE20S(JAE)</p>
2	VLED	Power Supply, 12V Typ.	
3	VLED	Power Supply, 12V Typ.	
4	VLED	Power Supply, 12V Typ.	
5	VLED	Power Supply, 12V Typ.	
6	GND	Ground	
7	GND	Ground	
8	GND	Ground	
9	GND	Ground	
10	GND	Ground	
11	LED_EN	High(5V): Backlight On, Low: Backlight Off	
12	PWM	System PWM input for dimming control	
13	NC	No connection	
14	NC	No connection	
15	NC	No connection	
16	NC	No connection	
17	NC	No connection	
18	NC	No connection	
19	NC	No connection	
20	NC	No connection	

3-3. Connection between Host system and LVDS receiver

Connection between Host system and LVDS receiver should be different by input signal condition(8bit or 6bit). Please refer to 3.3.1 and 3.3.2.

3.3.1 Input data signal : 8bit

If input data is 8bit, connect MSB 2bit of R,G,B to TD0~TD5 pin of LVDS Tx. Refer to FIG 1 and Table 5 for more detail.

Fig 1. REQUIRED SIGNAL ASSIGNMENT FOR LVDS TRANSMITTER(THC63LVDM83R) – 8Bit

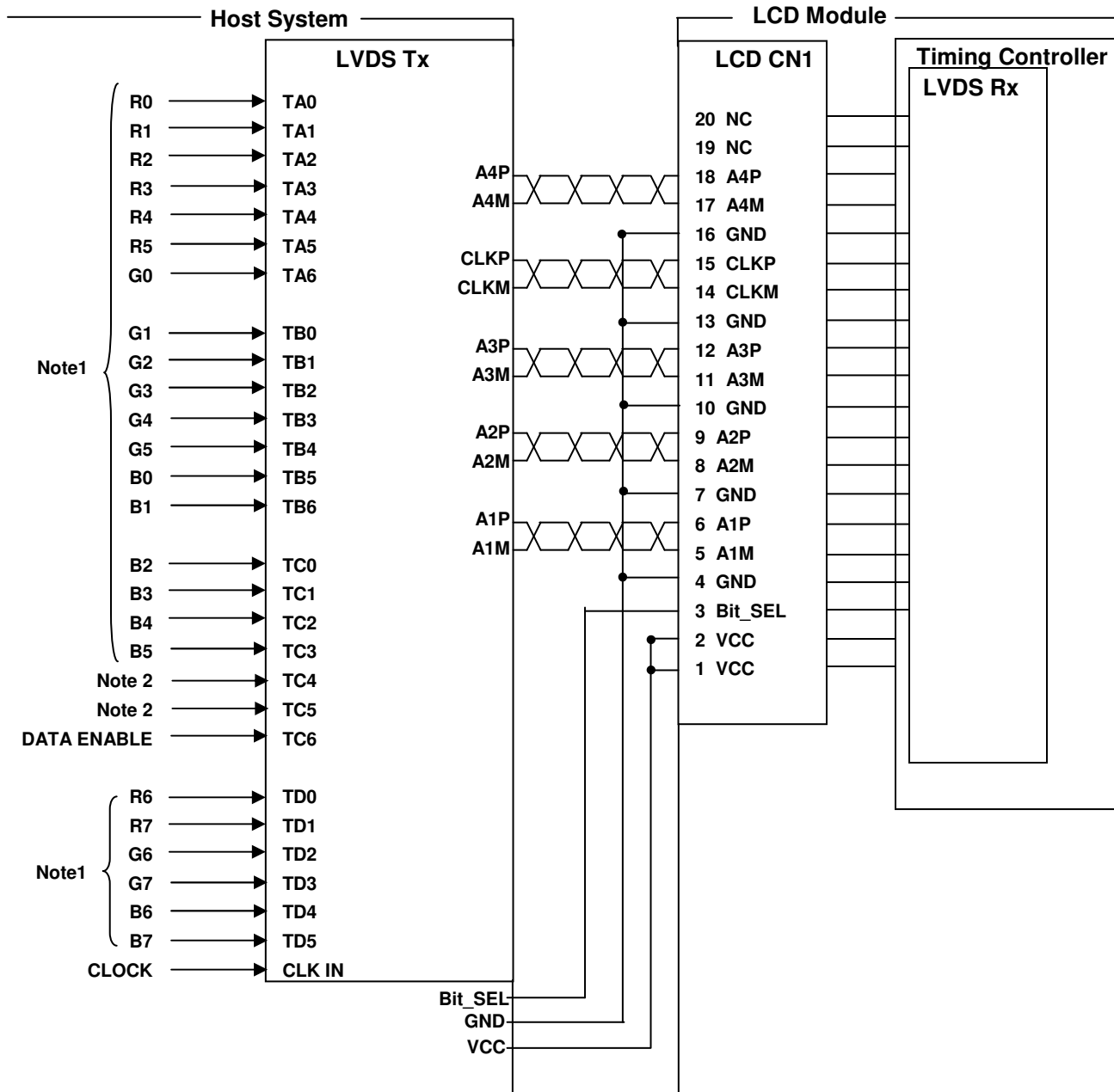

Note1 : See "Table 5. Input pin map of LVDS Tx for 8bit and 6bit"

Note2 : Connect to ground.

3.3.2 Input data signal : 6bit

If input data is 6bit, pin map of host system should be different with 8bit. Refer to FIG 2 and Table 5 for more detail.

Fig 2. REQUIRED SIGNAL ASSIGNMENT FOR LVDS TRANSMITTER(THC63LVDM83R) – 6Bit

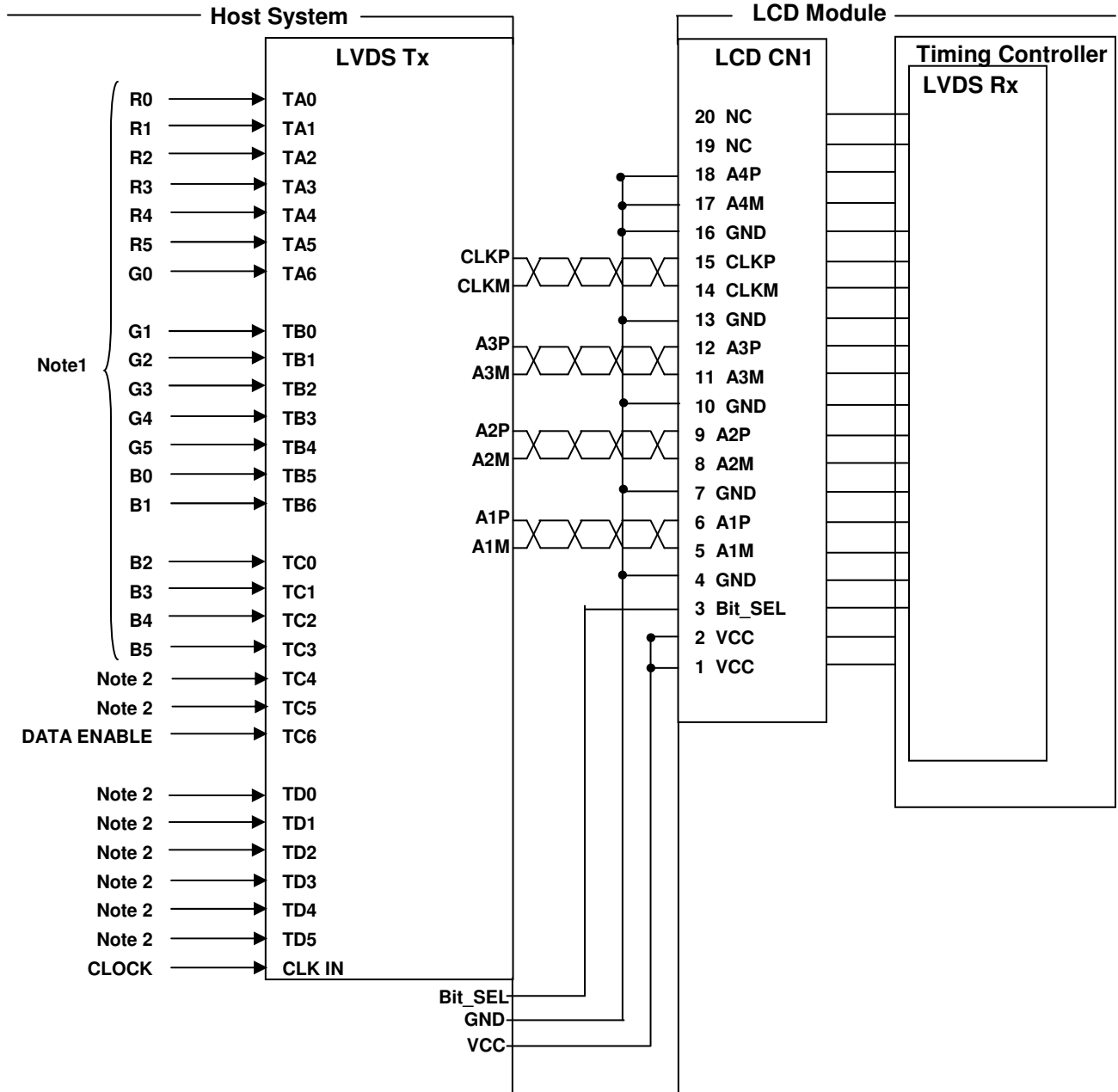

Note 1 : R0(6bit) is not equal to R0(8bit). See "Table 5. Input pin map of LVDS Tx for 8bit and 6bit" for more detail.

Note 2 : Connect to ground.

Product Specification

Table 5. Input pin map of LVDS Tx for 8bit and 6bit

TTL Data		LVDS Tx input Pin (Pin #)	TTL Data		LVDS Tx input Pin (Pin #)	Note
8bit			6Bit			
LSB	R0	TA0 (51)		-	-	If input data is 6bit, don't connect LSB two data to LVDS Tx.
	R1	TA1 (52)		-	-	
	R2	TA2 (54)	LSB	R0	TA0 (51)	TTL R2(8bit)=TTL R0(6bit)
	R3	TA3 (55)		R1	TA1 (52)	TTL R3(8bit)=TTL R1(6bit)
	R4	TA4 (56)		R2	TA2 (54)	TTL R4(8bit)=TTL R2(6bit)
	R5	TA5 (3)		R3	TA3 (55)	TTL R5(8bit)=TTL R3(6bit)
	R6	TD0 (50)		R4	TA4 (56)	TTL R6(8bit)=TTL R4(6bit)
MSB	R7	TD1 (2)	MSB	R5	TA5 (3)	TTL R7(8bit)=TTL R5(6bit)
LSB	G0	TA6 (4)		-	-	If input data is 6bit, don't connect LSB two data to LVDS Tx.
	G1	TB0 (6)		-	-	
	G2	TB1 (7)	LSB	G0	TA6 (4)	TTL G2(8bit)=TTL G0(6bit)
	G3	TB2 (11)		G1	TB0 (6)	TTL G3(8bit)=TTL G1(6bit)
	G4	TB3 (12)		G2	TB1 (7)	TTL G4(8bit)=TTL G2(6bit)
	G5	TB4 (14)		G3	TB2 (11)	TTL G5(8bit)=TTL G3(6bit)
	G6	TD2 (8)		G4	TB3 (12)	TTL G6(8bit)=TTL G4(6bit)
MSB	G7	TD3 (10)	MSB	G5	TB4 (14)	TTL G7(8bit)=TTL G5(6bit)
LSB	B0	TB5 (15)		-	-	If input data is 6bit, don't connect LSB two data to LVDS Tx.
	B1	TB6 (19)		-	-	
	B2	TC0 (20)	LSB	B0	TB5 (15)	TTL B2(8bit)=TTL B0(6bit)
	B3	TC1 (22)		B1	TB6 (19)	TTL B3(8bit)=TTL B1(6bit)
	B4	TC2 (23)		B2	TC0 (20)	TTL B4(8bit)=TTL B2(6bit)
	B5	TC3 (24)		B3	TC1 (22)	TTL B5(8bit)=TTL B3(6bit)
	B6	TD4 (16)		B4	TC2 (23)	TTL B6(8bit)=TTL B4(6bit)
MSB	B7	TD5 (18)	MSB	B5	TC3 (24)	TTL B7(8bit)=TTL B5(6bit)
Data Enable		TC6 (30)	Data Enable		TC6 (30)	
CLOCK		CLKIN (31)	CLOCK		CLKIN (31)	

Note : LVDS Tx - THC63LVDM83R(Thine) or equivalent.

Product Specification

3-4. LVDS Signal Timing Specifications

3-4.1. DC specification

Description	Symbol	Min	Max	Unit	Notes
LVDS Differential Voltage	$ V_{ID} $	100	600	mV	-
LVDS Common mode Voltage	V_{CM}	0.6	1.8	V	-
LVDS Input Voltage Range	V_{IN}	0.3	2.1	V	-

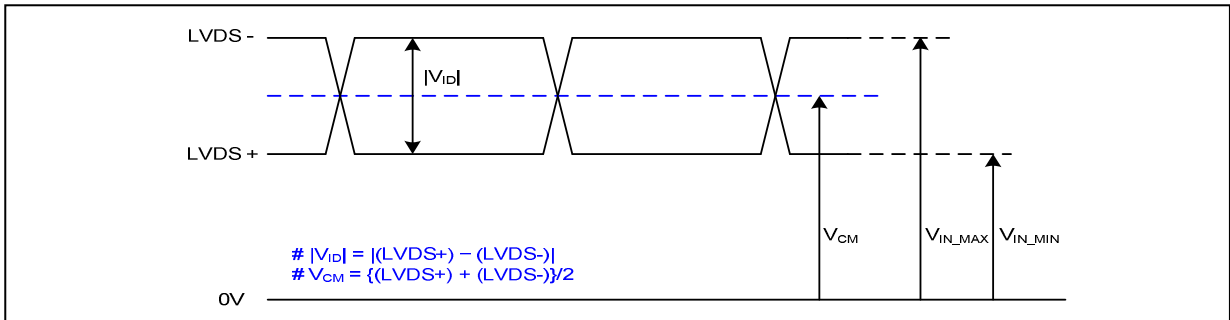

3-4.2. Data format

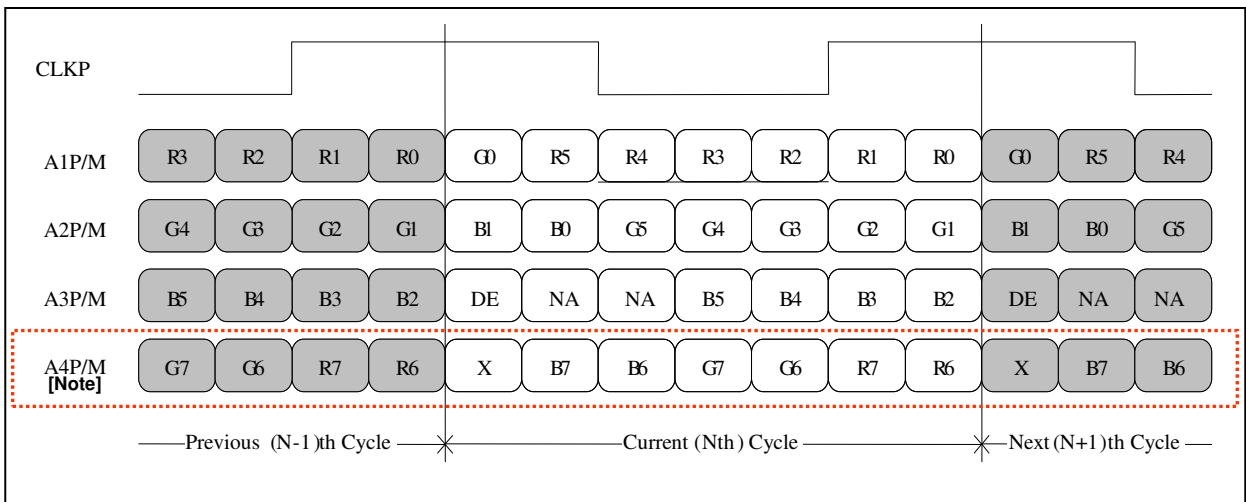

Note : When input condition of 'Bit SEL' is low for 6bit operation(262,144 colors), A4 P/M is excluded among the pairs

Product Specification

3-4.3. AC specification

Symbol	Parameter	Min	Typ	Max	Unit
tCLK	LVDS CLK Period	25	25.9	27	ns
tRCH	CLK OUT High Time	-	4T/7-	-	ns
tRCL	CLK OUT Low Time	-	3T/7	-	ns
tRS	Data Setup to CLK OUT	3T/7-2.5			ns
TRH	Data Hold from CLK OUT	4T/7-3.5	-	-	ns
tRIP1	Input Data Position 0	-0.4	0.0	0.4	ns
tRIP0	Input Data Position 1	T/7-0.4	T/7	T/7+0.4	ns
tRIP6	Input Data Position 2	2T/7-0.4	2T/7	2T/7+0.4	ns
tRIP5	Input Data Position 3	3T/7-0.4	3T/7	3T/7+0.4	ns
tRIP4	Input Data Position 4	4T/7-0.4	4T/7	4T/7+0.4	ns
tRIP3	Input Data Position 5	5T/7-0.4	5T/7	5T/7+0.4	ns
tRIP2	Input Data Position 6	6T/7-0.4	6T/7	6T/7+0.4	ns

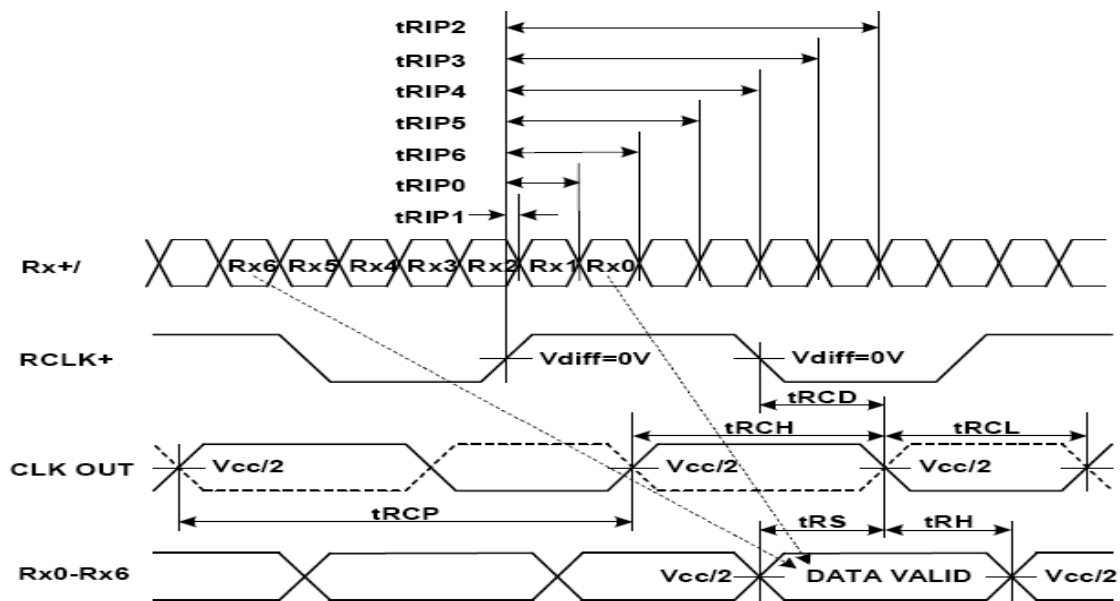

< AC Timing Diagram >

Product Specification

3-5. Signal Timing Specification

This is the signal timing required at the input of the CNT1. All of the interface signal timing should be satisfied with the following specifications and specifications of LVDS Tx/Rx for its proper operation.

Table 6. Timing Table

ITEM	Symbol	Min	Typ	Max	Unit	Note
DCLK	Frequency	fCLK	37.0	38.5	40.0	MHz
Hsync	Period	tHP	990	1024	1100	tCLK
	Width	tWH	12	64	120	
Vsync	Period	tVP	606	625	730	tHP
	Width	tWV	1	6	24	
Data Enable	Horizontal back porch	tHBP	32	88	120	tCLK
	Horizontal front porch	tHFP	32	72	80	
	Horizontal Active	tWHA	800	800	800	
	Vertical back porch	tVBP	2	15	22	tHP
	Vertical front porch	tVFP	3	4	5	
	Vertical Active	tWVA	600	600	600	

Notes

1. DE Only mode operation.
2. tHFP, tWH and tHBP should be any times of a character number (8). $tHFP+tWH+tHBP < (1/2)tWHA$
3. No variation of the total number of Hsync and DE in a frame is required for normal operation.
4. No variation of the total number of clock in a Hsync period for tVBP is required for normal operation.

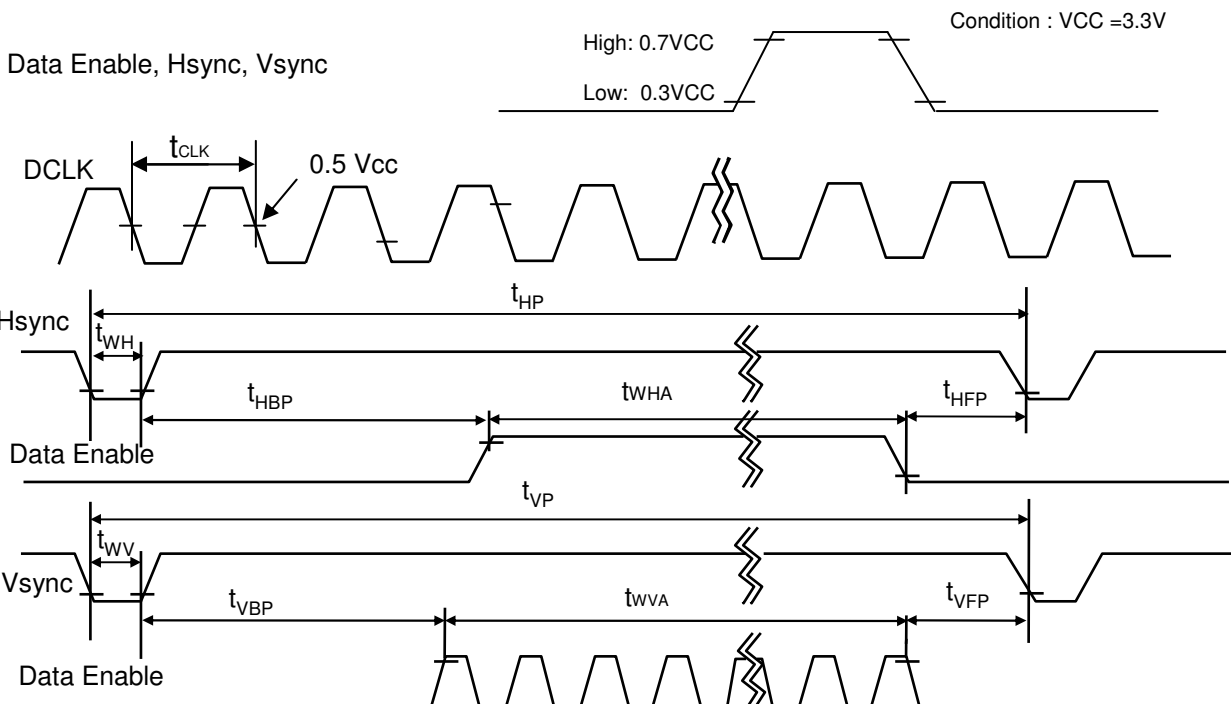

3-6. Display Color and Input Signals

3-6-1. Input Condition of Bit_SEL signal and data signals

LB121S03-TL03 can display 16,777,216 color in 256 gray scales and 262,144 colors in 64 gray scales by input condition of Bit_SEL signal and data signals. See following table.

Table 7. FRC and Input data signal

Input data signals	Bit_SEL	Input signal for Pin 1 of CN1	Input signal for Pin 2 of CN1	Display color	Notes
8-bit	High/NC	A4P	A4M	16,777,216	1,3
6-bit	Low	GND	GND	262,144	2,4

Note 1 : See “3-6-2.Color Input Data Reference(16,777,216)”

Note 2 : See “3-6-3. Color Input Data Reference(262,144)”

Note 3 : See “3-3-1. Input data signal : 8bit”

Note 4 : See “3-3-2. Input data signal : 6bit”

Product Specification

3-6-2. Color Input Data Reference(16,777,216 color)

The brightness of each primary color (red, green and blue) is based on the 8-bit gray scale data input for the color ; the higher the binary input, the brighter the color. The table below provides a reference for color versus data input. Please see “3-6-1. Input Condition of FRC signal and data signals” for 16,777,216 color.

Table 8-1. COLOR DATA REFERENCE

Color		Input Color Data																							
		RED								GREEN								BLUE							
		MSB				LSB				MSB				LSB				MSB				LSB			
		R7	R6	R5	R4	R3	R2	R1	R0	G7	G6	G5	G4	G3	G2	G1	G0	B7	B6	B5	B4	B3	B2	B1	B0
Basic Color	Black	0	0	0	0	0	0	0	0	0	0	0	0	0	0	0	0	0	0	0	0	0	0	0	0
	Red	1	1	1	1	1	1	1	1	0	0	0	0	0	0	0	0	0	0	0	0	0	0	0	0
	Green	0	0	0	0	0	0	0	0	1	1	1	1	1	1	1	1	0	0	0	0	0	0	0	0
	Blue	0	0	0	0	0	0	0	0	0	0	0	0	0	0	0	0	1	1	1	1	1	1	1	1
	Cyan	0	0	0	0	0	0	0	0	1	1	1	1	1	1	1	1	1	1	1	1	1	1	1	1
	Magenta	1	1	1	1	1	1	1	1	0	0	0	0	0	0	0	0	1	1	1	1	1	1	1	1
	Yellow	1	1	1	1	1	1	1	1	1	1	1	1	1	1	1	1	0	0	0	0	0	0	0	0
	White	1	1	1	1	1	1	1	1	1	1	1	1	1	1	1	1	1	1	1	1	1	1	1	1
RED	RED (000)	0	0	0	0	0	0	0	0	0	0	0	0	0	0	0	0	0	0	0	0	0	0	0	0
	RED (001)	0	0	0	0	0	0	0	1	0	0	0	0	0	0	0	0	0	0	0	0	0	0	0	0
							
	RED (255)	1	1	1	1	1	1	1	0	0	0	0	0	0	0	0	0	0	0	0	0	0	0	0	0
	RED (255)	1	1	1	1	1	1	1	1	0	0	0	0	0	0	0	0	0	0	0	0	0	0	0	0
GREEN	GREEN (000)	0	0	0	0	0	0	0	0	0	0	0	0	0	0	0	0	0	0	0	0	0	0	0	0
	GREEN (001)	0	0	0	0	0	0	0	0	0	0	0	0	0	0	0	1	0	0	0	0	0	0	0	0
							
	GREEN (255)	0	0	0	0	0	0	0	0	1	1	1	1	1	1	1	0	0	0	0	0	0	0	0	0
	GREEN (255)	0	0	0	0	0	0	0	0	1	1	1	1	1	1	1	1	0	0	0	0	0	0	0	0
BLUE	BLUE (000)	0	0	0	0	0	0	0	0	0	0	0	0	0	0	0	0	0	0	0	0	0	0	0	0
	BLUE (001)	0	0	0	0	0	0	0	0	0	0	0	0	0	0	0	0	0	0	0	0	0	0	0	1
							
	BLUE (254)	0	0	0	0	0	0	0	0	0	0	0	0	0	0	0	0	1	1	1	1	1	1	1	0
	BLUE (255)	0	0	0	0	0	0	0	0	0	0	0	0	0	0	0	0	1	1	1	1	1	1	1	1

Product Specification

3-6-3. Color Input Data Reference(262,144 color)

The brightness of each primary color (red, green and blue) is based on the 6-bit gray scale data input for the color ; the higher the binary input, the brighter the color. The table below provides a reference for color versus data input. Please see “3-6-1. Input Condition of FRC signal and data signals” for 262,144 color.

Table 8-2. COLOR DATA REFERENCE

Color		Input Color Data																					
		RED						GREEN						BLUE									
		MSB						LSB		MSB						LSB		MSB					
		R5	R4	R3	R2	R1	R0	G5	G4	G3	G2	G1	G0	B5	B4	B3	B2	B1	B0				
Basic Color	Black	0	0	0	0	0	0	0	0	0	0	0	0	0	0	0	0	0	0				
	Red	1	1	1	1	1	1	0	0	0	0	0	0	0	0	0	0	0	0				
	Green	0	0	0	0	0	0	1	1	1	1	1	1	0	0	0	0	0	0				
	Blue	0	0	0	0	0	0	0	0	0	0	0	0	1	1	1	1	1	1				
	Cyan	0	0	0	0	0	0	1	1	1	1	1	1	1	1	1	1	1	1				
	Magenta	1	1	1	1	1	1	0	0	0	0	0	0	1	1	1	1	1	1				
	Yellow	1	1	1	1	1	1	1	1	1	1	1	1	0	0	0	0	0	0				
	White	1	1	1	1	1	1	1	1	1	1	1	1	1	1	1	1	1	1				
RED	RED (00)	0	0	0	0	0	0	0	0	0	0	0	0	0	0	0	0	0	0				
	RED (01)	0	0	0	0	0	1	0	0	0	0	0	0	0	0	0	0	0	0				
									
	RED (62)	1	1	1	1	1	0	0	0	0	0	0	0	0	0	0	0	0	0				
	RED (63)	1	1	1	1	1	1	0	0	0	0	0	0	0	0	0	0	0	0				
GREEN	GREEN (00)	0	0	0	0	0	0	0	0	0	0	0	0	0	0	0	0	0	0				
	GREEN (01)	0	0	0	0	0	0	0	0	0	0	0	1	0	0	0	0	0	0				
									
	GREEN (62)	0	0	0	0	0	0	1	1	1	1	1	0	0	0	0	0	0	0				
	GREEN (63)	0	0	0	0	0	0	1	1	1	1	1	1	0	0	0	0	0	0				
BLUE	BLUE (00)	0	0	0	0	0	0	0	0	0	0	0	0	0	0	0	0	0	0				
	BLUE (01)	0	0	0	0	0	0	0	0	0	0	0	0	0	0	0	0	0	1				
									
	BLUE (62)	0	0	0	0	0	0	0	0	0	0	0	0	1	1	1	1	1	0				
	BLUE (63)	0	0	0	0	0	0	0	0	0	0	0	0	1	1	1	1	1	1				

Product Specification

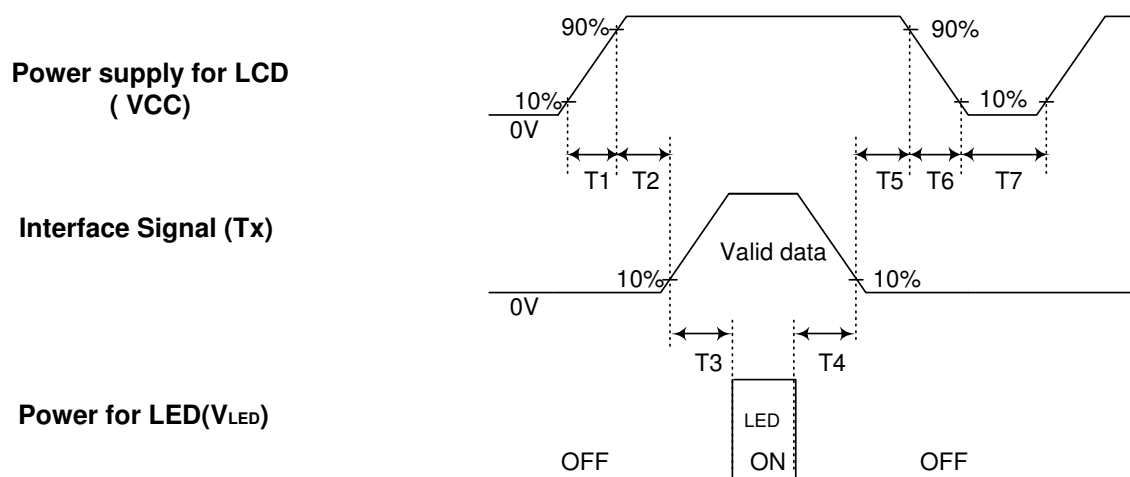
3-7. Power Sequence
3-7-1. LCD Driving circuit

Table 9. POWER SEQUENCE TABLE

Parameter	Value			Units
	Min.	Typ.	Max.	
T ₁	-	-	10	(ms)
T ₂	10	-	50	(ms)
T ₃	200	-	-	(ms)
T ₄	200	-	-	(ms)
T ₅	0	-	50	(ms)
T ₆	-	-	10	(ms)
T ₇	2	-	-	(s)

Note)

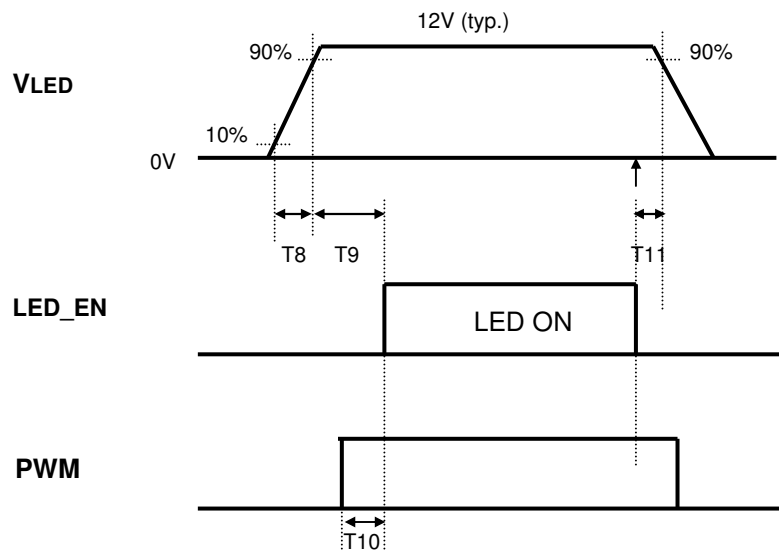
1. Please avoid floating state of interface signal at invalid period.
2. When the interface signal is invalid, be sure to pull down the power supply for LCD VCC to 0V.
3. Lamp power must be turn on after power supply for LCD and interface signal are valid.

3-7-2. Sequence for LED Driver

Parameter	Value			Units
	Min.	Typ.	Max.	
T_8	20	-	-	ms
T_9	500	-	-	ms
T_{10}	0	-	-	ms
T_{11}	10	-	-	ms

Notes : 1. T_8 describes rising time of 0V to 12V and this parameter does not applied at restarting time.
 Even though T_{11} is over the specified value, there is no problem if I^2T spec of fuse is satisfied.

4. Optical Specification

Optical characteristics are determined after the unit has been 'ON' and stable for approximately 30 minutes in a dark environment at 25°C. The values specified are at an approximate distance 50cm from the LCD surface at a viewing angle of Φ and Θ equal to 0°.

FIG. 3 presents additional information concerning the measurement equipment and method.

FIG. 3 Optical Characteristic Measurement Equipment and Method

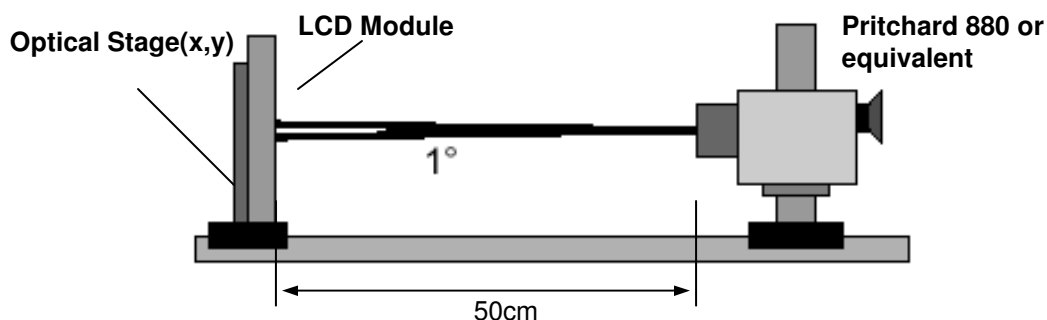

Table 10. OPTICAL CHARACTERISTICS

Ta=25°C, VCC=3.3V, fv=60Hz, Dclk= 38.5MHz, LED PWM=100%

Parameter	Symbol	Values			Units	Notes
		Min	Typ	Max		
Contrast Ratio	CR	400	500	-		1
Surface Luminance, white		360	450		cd/m ²	2
Luminance Variation	δ_{WHITE}	-	1.25	1.45		3
Response Time						4
Rise Time	Tr _R	-	10	20	ms	
Decay Time	Tr _D	-	20	30	ms	
Color Coordinates						
WHITE	Wx	TBD	TBD	TBD		
	Wy	TBD	TBD	TBD		
RED	Rx	TBD	TBD	TBD		
	Ry	TBD	TBD	TBD		
GREEN	Gx	TBD	TBD	TBD		
	Gy	TBD	TBD	TBD		
BLUE	Bx	TBD	TBD	TBD		
	By	TBD	TBD	TBD		
Viewing Angle						5
x axis, right($\Phi=0^\circ$)	Θ_r	65	70	-	degree	
x axis, left ($\Phi=180^\circ$)	Θ_l	65	70	-	degree	
y axis, up ($\Phi=90^\circ$)	Θ_u	50	55	-	degree	
y axis, down ($\Phi=270^\circ$)	Θ_d	60	65	-	degree	

Product Specification

Note)

1. Contrast Ratio(CR) is defined mathematically as

$$\text{Contrast Ratio} = \frac{\text{Surface Luminance with all white pixels}}{\text{Surface Luminance with all black pixels}}$$

2. Surface luminance is the center point across the LCD surface 50cm from the surface with all pixels displaying white. For more information see FIG 3.

3. The variation in surface luminance, The Panel total variation (
- δ_{WHITE}
-) is determined by measuring
- L_N
- at each test position 1 through 5, and then dividing the maximum
- L_N
- of 5 points luminance by minimum
- L_N
- of 5 points luminance. For more information see FIG 4.

$$\delta_{\text{WHITE}} = \text{Maximum}(L_1, L_2, \dots, L_5) / \text{Minimum}(L_1, L_2, \dots, L_5)$$

4. Response time is the time required for the display to transition from white to black (rise time,
- Tr_R
-) and from black to white(Decay Time,
- Tr_D
-). For additional information see FIG 5.

5. Viewing angle is the angle at which the contrast ratio is greater than 10. The angles are determined for the horizontal or x axis and the vertical or y axis with respect to the z axis which is normal to the LCD surface. For more information see FIG 6.

6. Gray scale specification

 * $f_V=60\text{Hz}$

Gray Level	Luminance [%] (Typ)
L0	0.2
L31	0.8
L63	4.0
L95	10.5
L127	19.5
L159	33.0
L191	52.0
L223	75.0
L255	100

FIG. 4 Luminance

<measuring point for surface luminance & measuring point for luminance variation>

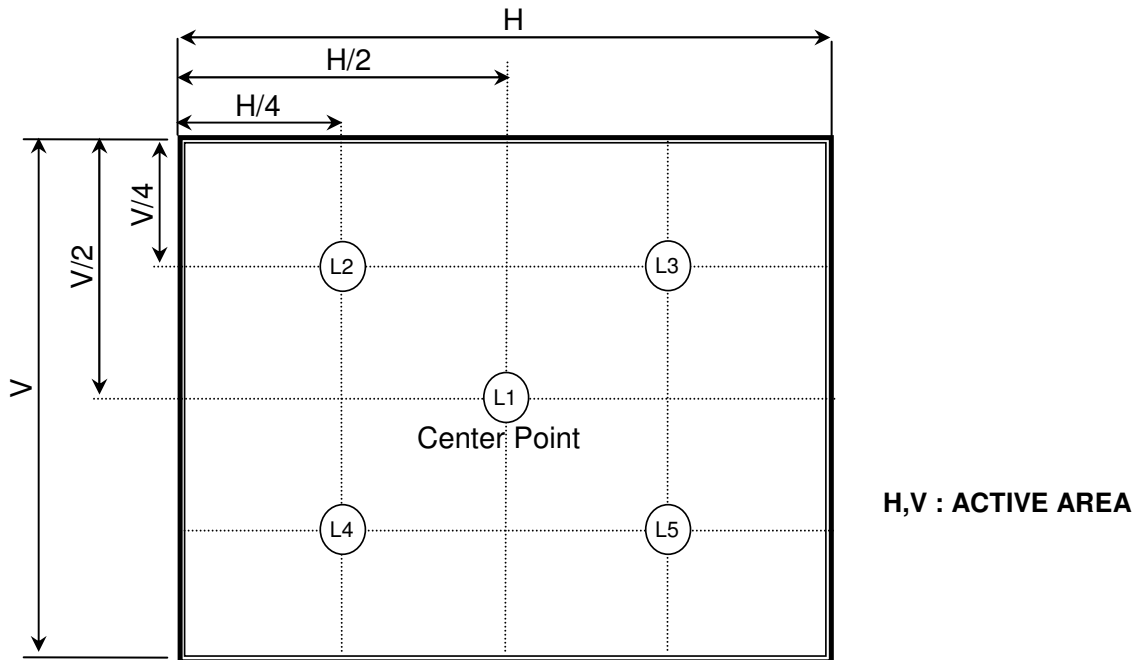

FIG. 5 Response Time

The response time is defined as the following figure and shall be measured by switching the input signal for "black" and "white".

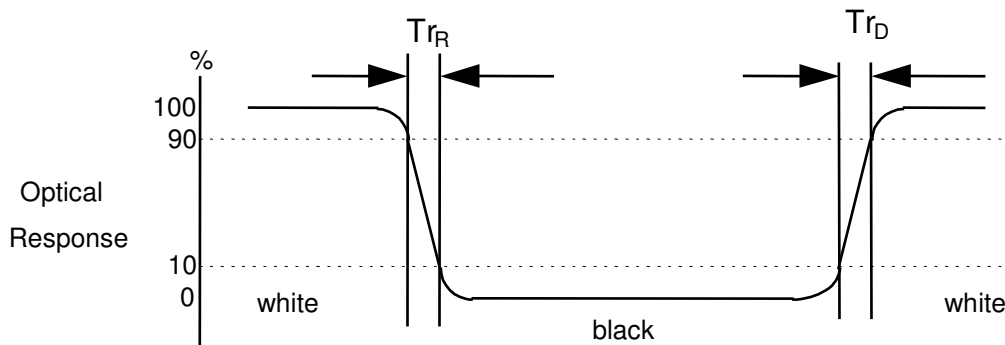
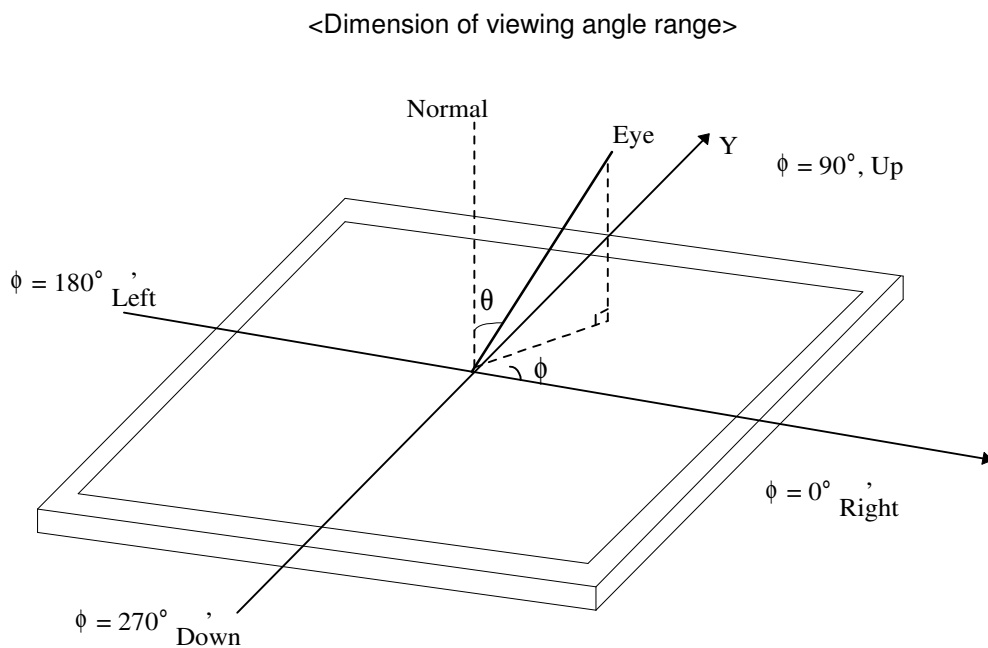

FIG. 6 Viewing angle



Product Specification

5. Mechanical Characteristics

The contents provide general mechanical characteristics for the model LB121S03-TL03. In addition the figures in the next page are detailed mechanical drawing of the LCD.

PARAMETER	SPECIFICATION	
Outline Dimension	Horizontal	276.0 ± 0.5mm
	Vertical	209.0 ± 0.5mm
	Depth	9 (Typ)
Active Display Area	Horizontal	246.0 mm
	Vertical	184.5 mm
Weight	530g (Max.)	
Surface Treatment	Anti-glare treatment	

Product Specification

<FRONT VIEW>

Note) Unit:[mm], General tolerance: $\pm 0.5\text{mm}$

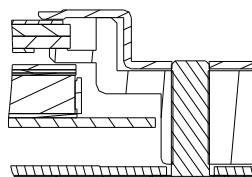
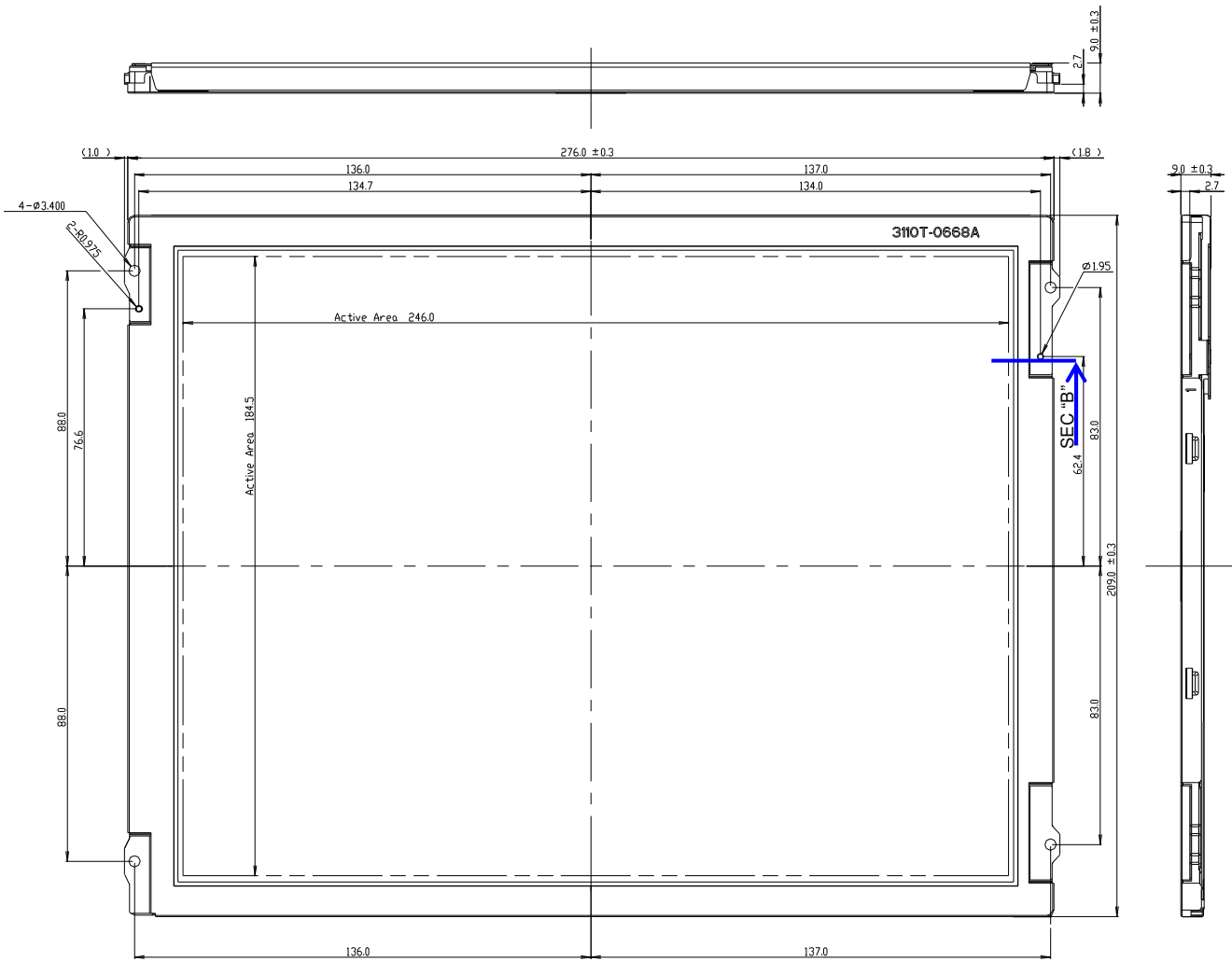

Detail B
Scale 4/1
Screw Torque Max 2.5kgf.cm

Product Specification

<REAR VIEW>

Note) Unit:[mm], General tolerance: ± 0.5mm

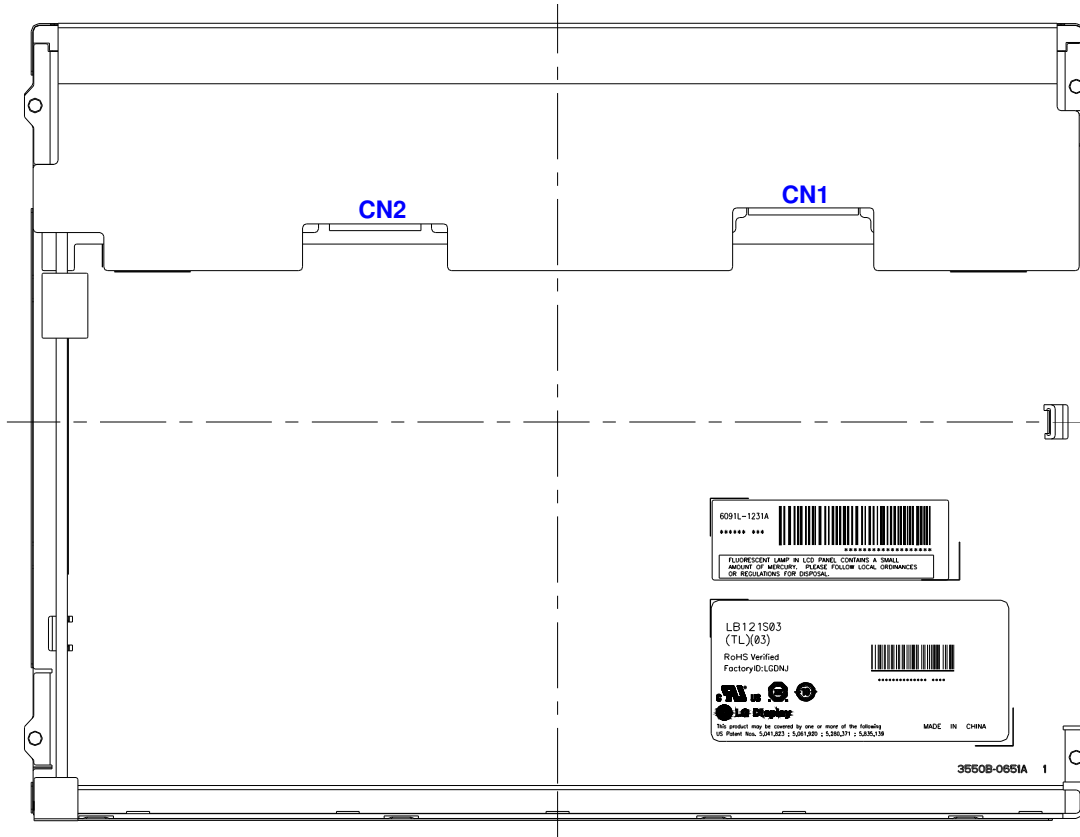

Product Specification

6. Reliability

Environment test condition

No.	Test Item	Conditions
1	High temperature storage test	Ta= 80°C, 240h
2	Low temperature storage test	Ta= -30°C, 240h
3	High temperature operation test	Ta= 70°C, 240h
4	Low temperature operation test	Ta= -20°C, 240h
5	Vibration test (non-operating)	Random, 10 ~ 300Hz, 1Grms,3 axis, 30min/axis
6	Shock test (non-operating)	Half sine wave, 120G, 2ms one shock of each six faces(l.e. run 180G 6ms for all six faces)
7	Altitude operating storage / shipment	0 ~ 10,000 feet (3,048m) 24Hr 0 ~ 40,000 feet (12,192m) 24Hr

{ Result Evaluation Criteria }

1. Evaluation should be tested after storage at room temperature for 24 hours.
2. There should be no change which might affect the practical display function when the display test quality test is conducted under normal operating condition.

7. International Standards

7-1. Safety

- a) UL 60950-1, Second Edition, Underwriters Laboratories Inc.
Information Technology Equipment - Safety - Part 1 : General Requirements.
- b) CAN/CSA C22.2 No.60950-1-07, Second Edition, Canadian Standards Association.
Information Technology Equipment - Safety - Part 1 : General Requirements.
- c) EN 60950-1:2006 + A11:2009, European Committee for Electrotechnical Standardization (CENELEC).
Information Technology Equipment - Safety - Part 1 : General Requirements.

7-2. Environment

- a) RoHS, Directive 2002/95/EC of the European Parliament and of the council of 27 January 2003

7-3. EMC

- a) ANSI C63.4 "Methods of Measurement of Radio-Noise Emissions from Low-Voltage Electrical and Electrical Equipment in the Range of 9kHz to 40GHz. "American National Standards Institute(ANSI), 1992
- b) C.I.S.P.R "Limits and Methods of Measurement of Radio Interface Characteristics of Information Technology Equipment." International Special Committee on Radio Interference.
- c) EN 55022 "Limits and Methods of Measurement of Radio Interface Characteristics of Information Technology Equipment." European Committee for Electro technical Standardization.(CENELEC), 1998

Product Specification

8. Packing

8-1. Designation of Lot Mark

a) Lot Mark

A	B	C	D	E	F	G	H	I	J	K	L	M
---	---	---	---	---	---	---	---	---	---	---	---	---

A,B,C : SIZE(INCH)

E : MONTH

N~Q: INTERNAL CODE(NO DIGIT)

D : YEAR

F ~ M : SERIAL NO.

Note

1. YEAR

Year	2001 2011	2002 2012	2003 2013	2004 2014	2005 2015	2006 2016	2007 2017	2008 2018	2009 2019	2010 2020
Mark	1	2	3	4	5	6	7	8	9	0

2. MONTH

Month	Jan	Feb	Mar	Apr	May	Jun	Jul	Aug	Sep	Oct	Nov	Dec
Mark	1	2	3	4	5	6	7	8	9	A	B	C

b) Location of Lot Mark

Serial No. is printed on the label. The label is attached to the backside of the LCD module.
 This is subject to change without prior notice.

8-2. Packing Form

a) Package quantity in one box : 16 pcs

b) Box Size : 425mm × 328mm × 350mm

9. PRECAUTIONS

Please pay attention to the followings when you use this TFT LCD module.

9-1. MOUNTING PRECAUTIONS

- (1) You must mount a module using holes arranged in four corners or four sides.
- (2) You should consider the mounting structure so that uneven force (ex. Twisted stress) is not applied to the module. And the case on which a module is mounted should have sufficient strength so that external force is not transmitted directly to the module.
- (3) Please attach the surface transparent protective plate to the surface in order to protect the polarizer. Transparent protective plate should have sufficient strength in order to resist external force.
- (4) You should adopt radiation structure to satisfy the temperature specification.
- (5) Acetic acid type and chlorine type materials for the cover case are not desirable because the former generates corrosive gas of attacking the polarizer at high temperature and the latter causes circuit break by electro-chemical reaction.
- (6) Do not touch, push or rub the exposed polarizers with glass, tweezers or anything harder than HB pencil lead. And please do not rub with dust clothes with chemical treatment. Do not touch the surface of polarizer for bare hand or greasy cloth.(Some cosmetics are detrimental to the polarizer.)
- (7) When the surface becomes dusty, please wipe gently with absorbent cotton or other soft materials like chamois soaks with petroleum benzene. Normal-hexane is recommended for cleaning the adhesives used to attach front / rear polarizers. Do not use acetone, toluene and alcohol because they cause chemical damage to the polarizer.
- (8) Wipe off saliva or water drops as soon as possible. Their long time contact with polarizer causes deformations and color fading.
- (9) Do not open the case because inside circuits do not have sufficient strength.

9-2. OPERATING PRECAUTIONS

- (1) The spike noise causes the mis-operation of circuits. It should be lower than following voltage :
 $V = \pm 200\text{mV}$ (Over and under shoot voltage)
- (2) Response time depends on the temperature.(In lower temperature, it becomes longer.)
- (3) Brightness depends on the temperature. (In lower temperature, it becomes lower.)
And in lower temperature, response time(required time that brightness is stable after turned on) becomes longer.
- (4) Be careful for condensation at sudden temperature change. Condensation makes damage to polarizer or electrical contacted parts. And after fading condensation, smear or spot will occur.
- (5) When fixed patterns are displayed for a long time, remnant image is likely to occur.
- (6) Module has high frequency circuits. Sufficient suppression to the electromagnetic interference shall be done by system manufacturers. Grounding and shielding methods may be important to minimized the interference.

※ If Customer supply incorrect Signal/Power, LGD cannot guarantee the Quality of LCM.

9-3. ELECTROSTATIC DISCHARGE CONTROL

Since a module is composed of electronic circuits, it is not strong to electrostatic discharge. Make certain that treatment persons are connected to ground through wrist band etc. And don't touch interface pin directly.

9-4. PRECAUTIONS FOR STRONG LIGHT EXPOSURE

Strong light exposure causes degradation of polarizer and color filter.

9-5. STORAGE

When storing modules as spares for a long time, the following precautions are necessary.

- (1) Store them in a dark place. Do not expose the module to sunlight or fluorescent light. Keep the temperature between 5°C and 35°C at normal humidity.
- (2) The polarizer surface should not come in contact with any other object.
It is recommended that they be stored in the container in which they were shipped.

9-6. HANDLING PRECAUTIONS FOR PROTECTION FILM

- (1) When the protection film is peeled off, static electricity is generated between the film and polarizer.
This should be peeled off slowly and carefully by people who are electrically grounded and with well ion-blown equipment or in such a condition, etc.
- (2) The protection film is attached to the polarizer with a small amount of glue. If some stress is applied to rub the protection film against the polarizer during the time you peel off the film, the glue is apt to remain on the polarizer.
Please carefully peel off the protection film without rubbing it against the polarizer.
- (3) When the module with protection film attached is stored for a long time, sometimes there remains a very small amount of glue still on the polarizer after the protection film is peeled off.
- (4) You can remove the glue easily. When the glue remains on the polarizer surface or its vestige is recognized, please wipe them off with absorbent cotton waste or other soft material like chamois soaked with normal-hexane.