



**PROPRIETARY NOTE**

THIS SPECIFICATION IS THE PROPERTY OF HYDIS AND SHALL NOT BE REPRODUCED OR COPIED WITHOUT THE WRITTEN PERMISSION OF HYDIS AND MUST BE RETURNED TO HYDIS UPON ITS REQUEST

**TITLE : HX121WX1 - 103**  
**Product Specification**

**HYDIS Technologies**

<b>SPEC. NUMBER</b> S864-1443	<b>PRODUCT GROUP</b> TFT LCD	<b>REV.</b> 0	<b>ISSUE DATE</b> 2011.07.06	<b>PAGE</b> 1 OF 32
----------------------------------	---------------------------------	------------------	---------------------------------	------------------------



PRODUCT GROUP

REV

ISSUE DATE

TFT LCD PRODUCT

0

2011.07.06

### REVISION HISTORY

REV.	ECN NO.	DESCRIPTION OF CHANGES	DATE	PREPARED
0		▪ Initial Release	11.07.06	J.T LEE

SPEC. NUMBER  
S864-1443

SPEC TITLE  
HX121WX1-103 Product Specification

PAGE  
2 OF 32



PRODUCT GROUP

REV

ISSUE DATE

TFT LCD PRODUCT

0

2011.07.06

## Contents

No	Item	Page
1.0	General Description	4
2.0	Absolute Maximum Ratings	6
3.0	Electrical Specifications	7
4.0	Optical Specifications	9
5.0	Interface Connections	14
6.0	Input Signals, Basic Display Colors & Gray Scale of Colors	16
7.0	Power Sequence	19
8.0	Mechanical Characteristics	20
9.0	Mechanical Drawing	21
10.0	Reliability Test	23
11.0	Handling & Cautions	23
12.0	Labels	25
13.0	Packing Information	27
14.0	EDID	29

SPEC. NUMBER  
S864-1443

SPEC TITLE  
HX121WX1-103 Product Specification

PAGE  
3 OF 32

## 1.0 GENERAL DESCRIPTION

### 1.1 Introduction

HX121WX1-103 is a color active matrix TFT LCD module using amorphous silicon TFT's (Thin Film Transistors) as an active switching devices. This module has a 12.1 inch diagonally measured active area with WXGA resolutions (1280 horizontal by 800 vertical pixel array). Each pixel is divided into RED, GREEN, BLUE dots which are arranged in vertical Stripe and this module can display 262,144 colors. The TFT-LCD panel used for this module is a low reflection and higher color type.

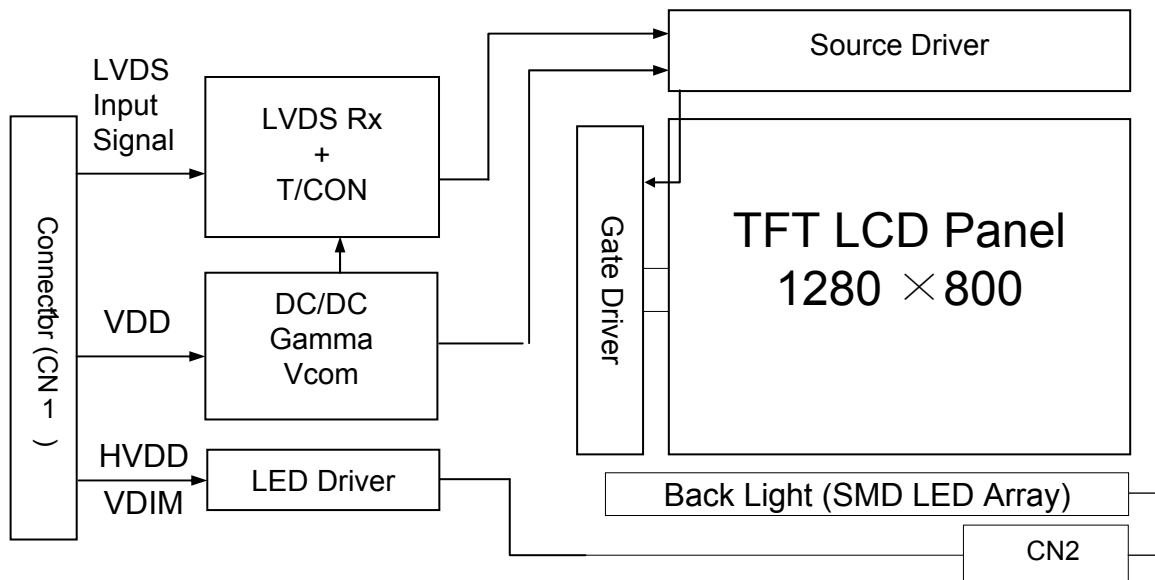

### 1.2 Features

- Thin and Light Weight
- 3.3 V Logic Power Supply
- 12V Back-light Power Supply
- 1 Channel LVDS Interface
- SMD LED (48EA) Array (Bottom Side/Horizontal Direction)
- 262,144 Colors
- Data Enable Signal Mode
- Side Mounting Frame
- Green Product (RoHS)



PRODUCT GROUP

REV

ISSUE DATE

TFT LCD PRODUCT

0

2011.07.06

### 1.3 Application

- Tablet PC (Wide type)

### 1.4 General Specifications

Parameter	Specification	Unit	Remarks
Active area	261.12(H) × 163.20(V)	mm	
Number of pixels	1280(H) × 800(V)	pixels	
Pixel pitch	0.204(H) × 0.204(V)	mm	
Pixel arrangement	RGB Vertical Stripe		
Display colors	262,144	colors	
Display mode	Normally Black		
Outline dimension	276.8±0.3(H) × 180.0±0.3(V) × 6.8(D:Max.)	mm	Note 1
Weight	265(Typ.) / 275(Max.)	g	Note 2
Back-light	SMD LED (48EA) Array		
Surface treatment	Anti Glare Low Reflection, 2H		

Note 1 : at PCB side

Note 2 : without digitizer

SPEC. NUMBER  
S864-1443

SPEC TITLE  
HX121WX1-103 Product Specification

PAGE  
5 OF 32

## 2.0 ABSOLUTE MAXIMUM RATINGS

The followings are maximum values which, if exceed, may cause faulty operation or damage to the unit.

Ta=25+/-2°C

Parameter	Symbol	Min.	Max.	Unit	Remarks
Logic Power Supply Voltage	V <sub>DD</sub>	-0.3	4.0	V	
Logic Power Supply Voltage	V <sub>IN</sub>	-0.3	V <sub>DD</sub> +0.3	V	
Back-light Power Supply Voltage	HV <sub>DD</sub>	-0.3	40	V	
Back-light LED Current	I <sub>LED</sub>	-	30	mA	Note 1
Back-light LED Reverse Voltage	V <sub>R</sub>	-	5	V	
Operating Temperature	T <sub>OP</sub>	0	+50	°C	Note 1, Note 2
Storage Temperature	T <sub>SP</sub>	-20	+60	°C	

Note 1. Ambient temperature vs allowable forward current are shown in the figure below.

Note 2. Temperature and relative humidity range are shown in the figure below.

90% RH Max. ( 40°C ≥ Ta)

Maximum wet - bulb temperature at 39°C or less. ( > 40°C ) No condensation.

Ambient Temperature vs. Maximum Forward Current

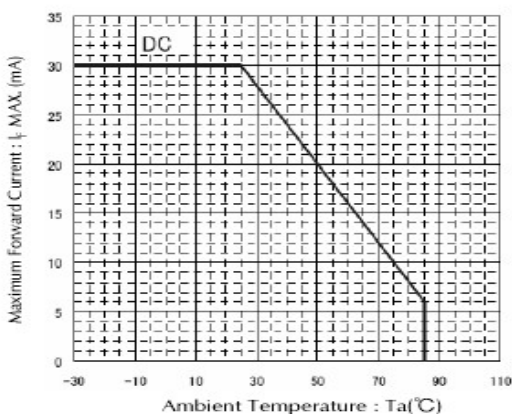

Relative Humidity

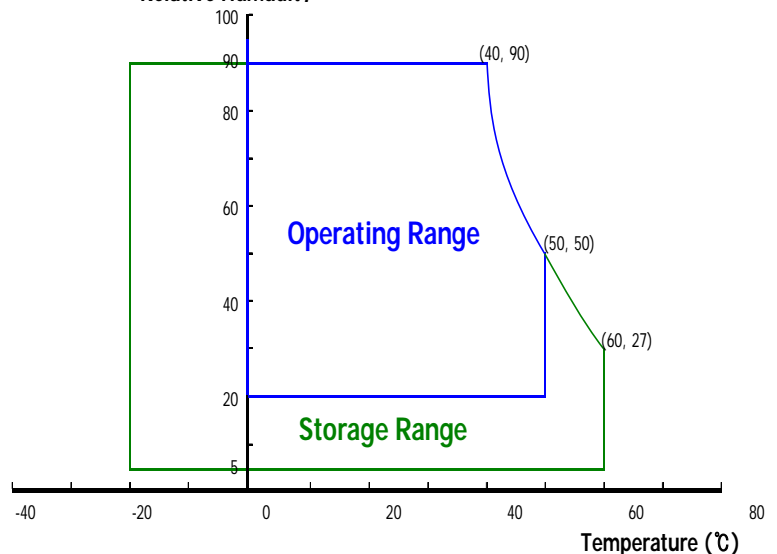

### 3.0 ELECTRICAL SPECIFICATIONS

#### 3.1 Electrical Specifications

< Table 3. Electrical Specifications >

Parameter		Min.	Typ.	Max.	Unit	Remarks
Logic Power Supply Voltage	$V_{DD}$	3.0	3.3	3.6	V	Note 1
Logic Power Supply Current	$I_{DD}$	-	346	470	mA	Note 1
Back-light Power Supply Voltage	$HV_{DD}$	6.0	12.0	20	V	Note 2
Back-light Power Supply Current	$I_{HVDD}$	-	255	305	mA	Note 2, 3
Back-light Power Consumption	$P_{BL}$	-	3.06	3.66	W	Note 2, 3
Power Consumption (EBL)	$P_{EBL}$	-	1.45	1.70	W	Note 1, 2, 3
LED Driver's Efficiency	$\eta$	-	82	-	%	Note 2, 3
Back-light PWM Frequency	$F_{PWM}$	200	280	1000	Hz	
High Level PWM Signal Voltage	$V_{PWMH}$	2.1	3.3	5.0	V	
Low Level PWM Signal Voltage	$V_{PWML}$	-	0	0.6	V	
Back-light LED Voltage / Back-light LED Total Voltage	$V_{LED} / V_{BL}$	-	3.1 / 37.2	3.5 / 42.0	V	Note 4
Back-light LED Current / Back-light LED Total Current	$I_{LED} / I_{BL}$	-	16.1 / 64.4	17.8 / 71.2	mA	Note 4
Life Time		12,000	-	-	Hrs	Based on LED
Power Consumption	$P_D$	-	1.00	1.55	W	Note 1
	$P_{LED}$	-	2.51	2.99	W	Note 4
	$P_{total}$	-	3.51	4.54	W	Note 1, 4

Notes : 1. The supply voltage is measured and specified at the interface connector of LCM.  
The current draw and power consumption specified is for 3.3V at 25°C.

a) Typ : Window XP pattern,      b) Max : Vertical Sub line pattern

c) EBL : Mosaic pattern ( 32 X 32 )

2. The power supply voltage and current is measured and specified at the interface connector of LCM including LED Driver.

3. Reference value, which is measured with LED Driver for 12V.

4. Reference value, which is measured without LED Driver.

5. Calculated value for reference ( $V_{LED} \times I_{LED} \times \# \text{ of LEDs (48EA) }$ ).

### 3.2 PWM Duty Ratio vs Brightness

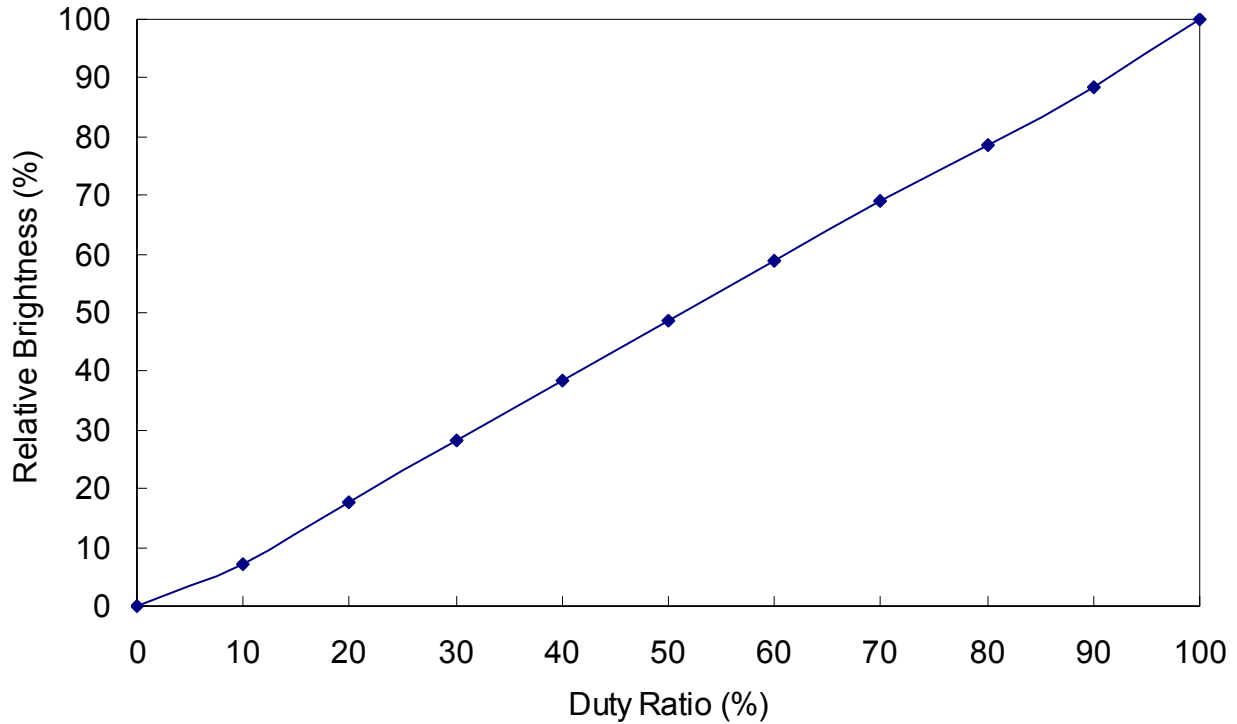

**Notes :**

In case of duty ratio 0%, LED can't illuminate itself so this state is LED off.

In case of duty ratio 100%, the brightness of LED is maximum and the state is LED on.





PRODUCT GROUP

REV

ISSUE DATE

TFT LCD PRODUCT

0

2011.07.06

**4.0 OPTICAL SPECIFICATIONS**

**4.1 Overview**

The test of optical specifications shall be measured in a dark room (ambient luminance  $\leq 1$  lux and temperature =  $25 \pm 2^\circ\text{C}$ ) with the equipment of Luminance meter system (Goniometer system and TOPCON BM-5A) and test unit shall be located at an approximate distance 50cm from the LCD surface at a viewing angle of  $\Theta$  and  $\Phi$  equal to  $0^\circ$ . We refer to  $\Theta_{\varnothing=0}$  ( $= \Theta_3$ ) as the 3 o'clock direction (the "right"),  $\Theta_{\varnothing=90}$  ( $= \Theta_{12}$ ) as the 12 o'clock direction ("upward"),  $\Theta_{\varnothing=180}$  ( $= \Theta_9$ ) as the 9 o'clock direction ("left") and  $\Theta_{\varnothing=270}$  ( $= \Theta_6$ ) as the 6 o'clock direction ("bottom"). While scanning  $\Theta$  and/or  $\Phi$ , the center of the measuring spot on the Display surface shall stay fixed. The backlight should be operating for 30 minutes prior to measurement.  $V_{DD}$  shall be  $3.3 \pm 0.3\text{V}$  at  $25^\circ\text{C}$ . Optimum viewing angle direction is 6 o'clock.

**4.2 Optical Specifications** <Table 4. Optical Specifications>

Parameter		Symbol	Condition	Min.	Typ.	Max.	Unit	Remarks
Viewing Angle range	Horizontal	$\Theta_3$	CR > 10	-	89	90	Deg.	Note 1
		$\Theta_9$		-	89	90	Deg.	
	Vertical	$\Theta_{12}$		-	89	90	Deg.	
		$\Theta_6$		-	89	90	Deg.	
Color Reproduction					42		%	
Luminance Contrast ratio		CR	$\Theta = 0^\circ$	-	500	-		Note 2
Luminance of White	5 Points	$Y_w$	$\Theta = 0^\circ$	250	300	-	cd/m <sup>2</sup>	Note 4 Note 5
White Luminance uniformity	5 Points	$\Delta Y_5$		80	-	-	%	
	13 Points	$\Delta Y_{13}$		60	-	-		
White Chromaticity		$W_x$	$\Theta = 0^\circ$	0.283	0.313	0.343		Note 3
		$W_y$		0.299	0.329	0.359		
Reproduction of color	Red	$R_x$	$\Theta = 0^\circ$	0.528	0.568	0.608		
		$R_y$		0.333	0.373	0.413		
	Green	$G_x$		0.313	0.353	0.393		
		$G_y$		0.549	0.589	0.629		
	Blue	$B_x$		0.112	0.152	0.192		
		$B_y$		0.005	0.135	0.175		
Response Time		Total ( $T_r + T_d$ )	$T_a = 25^\circ\text{C}$ $\Theta = 0^\circ$	-	30	-	ms	Note 6
Cross Talk		CT	$\Theta = 0^\circ$	-	-	2.0	%	Note 7

SPEC. NUMBER  
S864-1443

SPEC TITLE  
HX121WX1-103 Product Specification

PAGE  
9 OF 32



PRODUCT GROUP

REV

ISSUE DATE

TFT LCD PRODUCT

0

2011.07.06

Notes :

1. Viewing angle is the angle at which the contrast ratio is greater than 10. The viewing angles are determined for the horizontal or 3, 9 o'clock direction and the vertical or 6, 12 o'clock direction with respect to the optical axis which is normal to the LCD surface (see Figure1).

2. Contrast measurements shall be made at viewing angle of  $\Theta = 0$  and at the center of the LCD surface. Luminance shall be measured with all pixels in the view field set first to white, then to the dark (black) state (see Figure1). Luminance Contrast Ratio (CR) is defined mathematically as  $CR = \text{Luminance when displaying a white raster} / \text{Luminance when displaying a black raster}$ .

3. Reference only / Standard Front Surface Treatment Measured with green cover glass. The color chromaticity coordinates specified in Table 4 shall be calculated from the spectral data measured with all pixels first in red, green, blue and white. Measurements shall be made at the center of the panel.

SPEC. NUMBER  
S864-1443

SPEC TITLE  
HX121WX1-103 Product Specification

PAGE  
10 OF 32

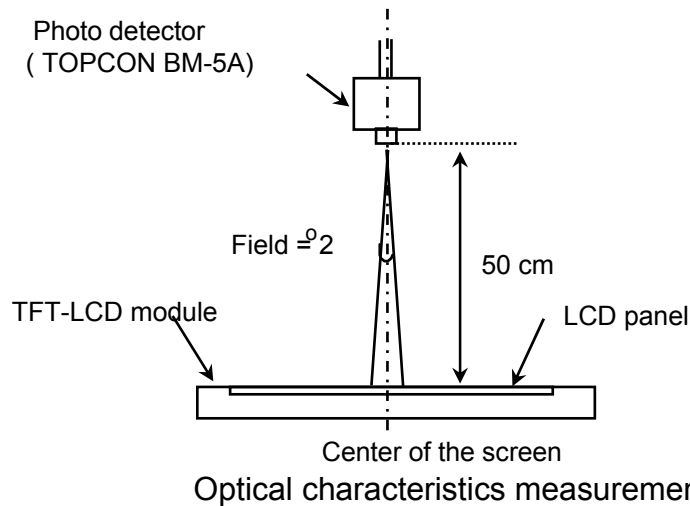
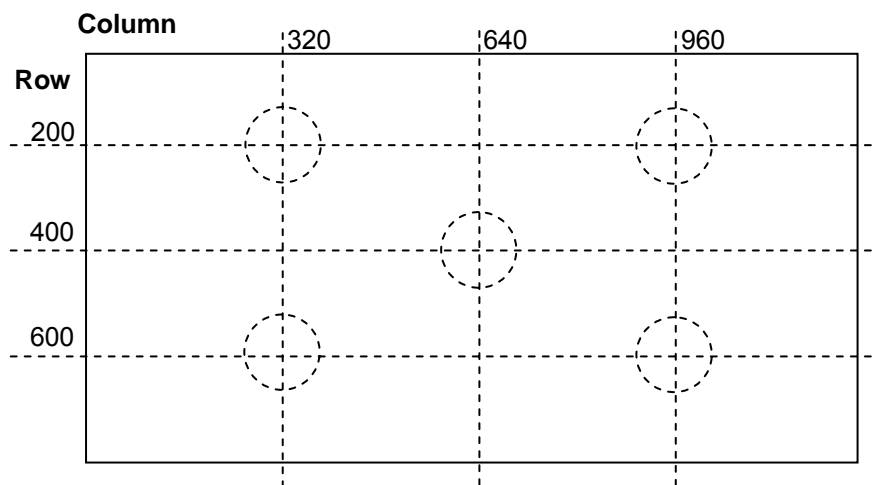
**4.3 Optical Measurements**
**Figure 1. Measurement Set Up**

**Figure 2. White Luminance and Uniformity Measurement Locations (5 points)**

**Note 4.**

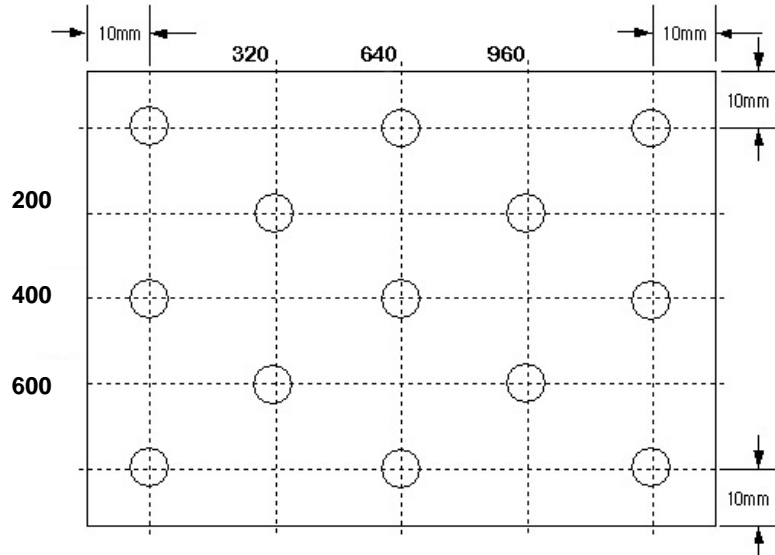
Luminance of white is defined as luminance values of 5 points across the LCD surface. Luminance shall be measured with all pixels in the view field set first to white. This measurement shall be taken at the locations shown in Figure 2 for a total of the measurements per display.

$$* Y_w = (\text{Sum of 5 Points Luminance} / 5)$$

**Figure 3. Uniformity Measurement Locations (13 points)**

Note 5.

The White luminance uniformity on LCD surface is then expressed as :  $\Delta Y5 = (\text{Minimum Luminance of five points} / \text{Maximum Luminance of five points}) \times 100\%$  (see Figure 2) ,  $\Delta Y13 = (\text{Minimum Luminance of 13 points} / \text{Maximum Luminance of 13 points}) \times 100\%$  (see Figure 3).

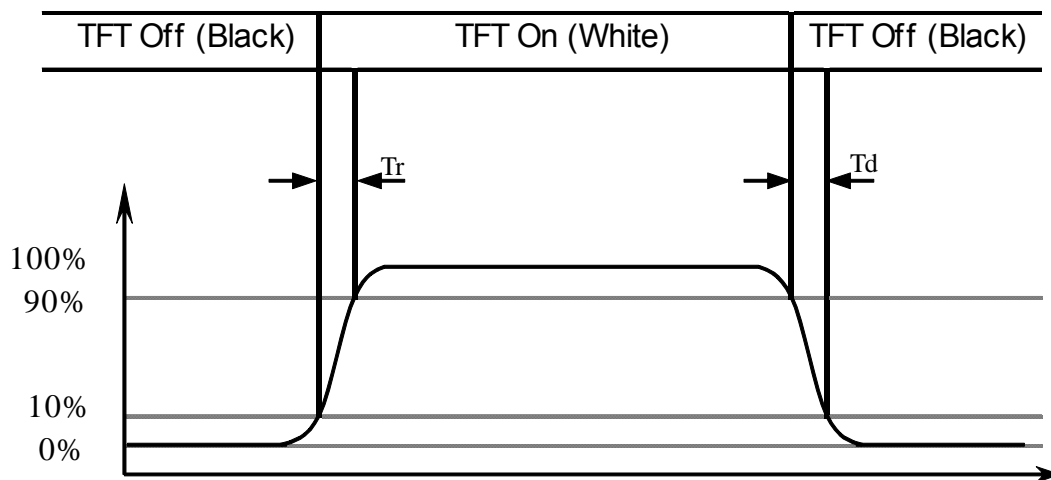
**Figure 4. Response Time Testing**

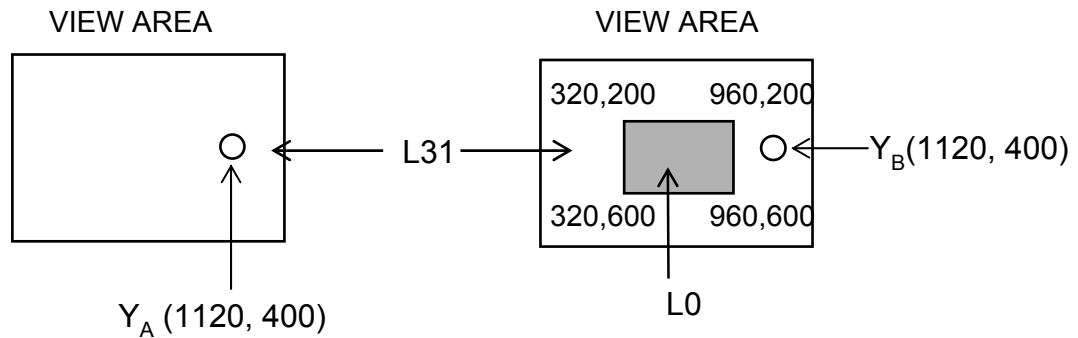
**Figure 5. Cross Modulation Test Description**

$$\text{Cross-Talk (\%)} = \left| \frac{Y_B - Y_A}{Y_B} \right| \times 100$$

Where:

$Y_A$  = Initial luminance of measured area (cd/m<sup>2</sup>)

$Y_B$  = Subsequent luminance of measured area (cd/m<sup>2</sup>)

The location measured will be exactly the same in both patterns

Note 6.

The electro-optical response time measurements shall be made as Figure 4 by switching the "data" input signal ON and OFF. The times needed for the luminance to change from 10% to 90% is Tr, and 90% to 10% is Td.

Note 7.

Cross-Talk of one area of the LCD surface by another shall be measured by comparing the luminance ( $Y_A$ ) of a 25mm diameter area, with all display pixels set to a gray level, to the luminance ( $Y_B$ ) of that same area when any adjacent area is driven dark (Refer to Figure 5).



PRODUCT GROUP

REV

ISSUE DATE

TFT LCD PRODUCT

0

2011.07.06

## 5.0 INTERFACE CONNECTIONS

### 5.1 Electrical Interface Connection

#### CN1 Interface Connector (I-PEX, 20455-040E)

Pin	Signal	Description
1	BIST	Built In Self Test
2	AVDD	Power Supply, 3.3V (typical)
3	AVDD	Power Supply, 3.3V (typical)
4	DVDD	DDC 3.3V power
5	NC	No Connection
6	SCL	DDC Clock
7	SDA	DDC Data
8	Rin0-	- LVDS differential data input (R0-R5, G0)
9	Rn0+	+ LVDS differential data input (R0-R5, G0)
10	GND	Ground
11	Rin1-	- LVDS differential data input (G1-G5, B0-B1)
12	Rn1+	+ LVDS differential data input (G1-G5, B0-B1)
13	GND	Ground
14	Rin2-	- LVDS differential data input (B2-B5,HS,VS, DE)
15	Rn2+	+ LVDS differential data input (B2-B5,HS,VS, DE)
16	GND	Ground
17	CIKIN-	- LVDS differential clock input
18	CIKIN+	+ LVDS differential clock input
19	GND	Ground
20	NC	No Connection
21	NC	No Connection
22	GND	Ground
23	NC	No Connection
24	NC	No Connection
25	GND	Ground
26	NC	No Connection
27	NC	No Connection
28	GND	Ground
29	NC	No Connection
30	NC	No Connection
31	VBL-	LED Ground
32	VBL-	LED Ground
33	VBL-	LED Ground
34	NC	No Connection
35	BLIM	PWM for luminance control (200~1KHz, 3.3V, 10~100%)
36	BL_Enable	BL On/Off (On: 2.0~3.3V, Off: 0~0.5V)
37	NC	No Connection
38	VBL+	*LED Power Supply 6V-20V
39	VBL+	*LED Power Supply 6V-20V
40	VBL+	*LED Power Supply 6V-20V

SPEC. NUMBER  
S864-1443SPEC TITLE  
HX121WX1-103 Product SpecificationPAGE  
14 OF 32

**5.2 Back-light Interface**
**CN2 LED FPC Connector (04-6298-009, Manufactured by Kyocera)**

Pin No.	Symbol	Function	Remark
1	Anode1	LED Anode Power Supply	LED Anode Power Supply (3.1V X 12EA = 37.2V)
2	Anode2	LED Anode Power Supply	
3	Anode3	LED Anode Power Supply	
4	Anode4	LED Anode Power Supply	
5	NC	Non-Connection	
6	Cathode1	LED Cathode Power Supply	LED Cathode Power Supply
7	Cathode2	LED Cathode Power Supply	
8	Cathode3	LED Cathode Power Supply	
9	Cathode4	LED Cathode Power Supply	

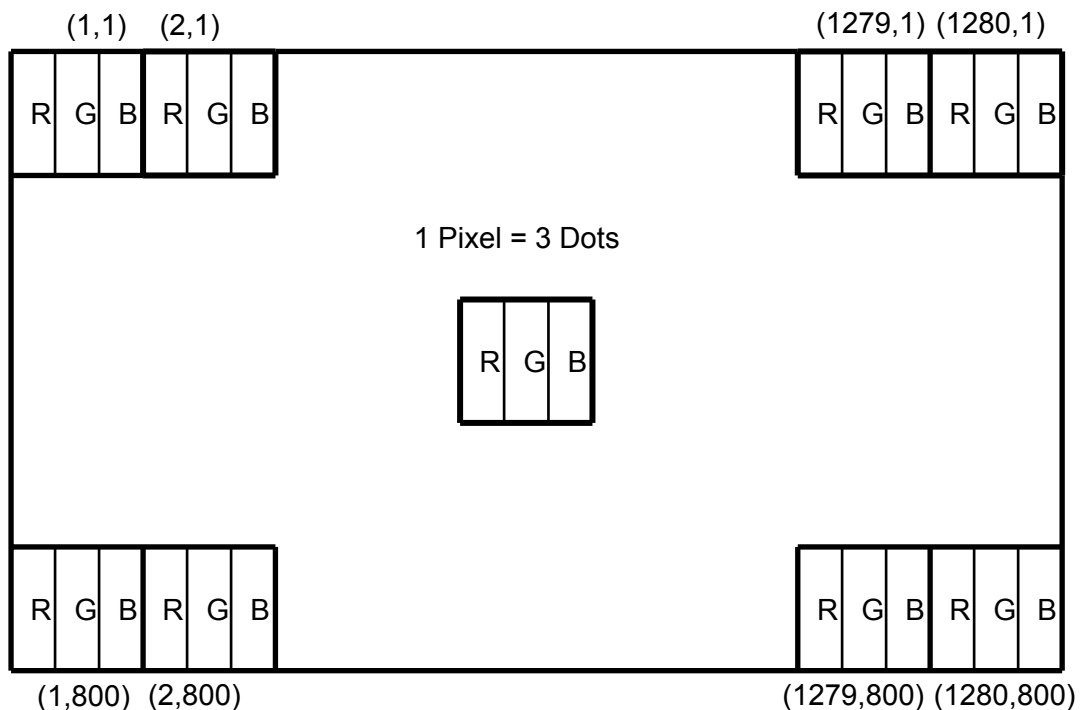
**5.4 Data Input Format**

## 6.0. SIGNAL TIMING SPECIFICATIONS

6.1 The 12.1" WXGA LCM is operated by the only DE (Data enable) mode (LVDS Transmitter Input)

Item	Symbol	Min.	Typ.	Max.	Unit
Frame Period	T1	810	814	-	Lines
Vertical Display Period	T2	-	800	-	Lines
One line Scanning Period	T3	1350	1418	-	Clocks
Horizontal Display Period	T4	-	1280	-	Clocks
Clock Frequency	1/T5	-	69.3	-	MHz

## 7.0 SIGNAL TIMING WAVEFORMS

### 7.1 Timing Waveforms of Interface Signal

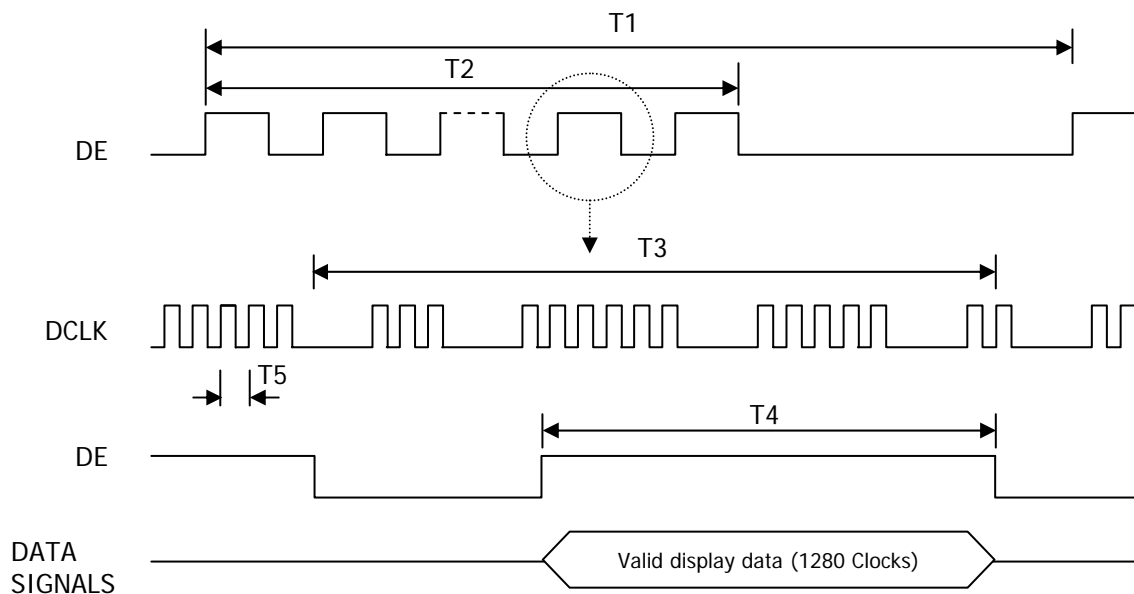



## 7.2 LVDS Rx Interface Timing Parameter

The specification of the LVDS Rx interface timing parameter

< LVDS Rx Interface Timing Specification >

Item	Symbol	Min.	Typ.	Max.	Unit	Remarks
CLKIN Period	tRCIP	12.50	14.43	25.00	nsec	
Input Data 0	tRIP0	-0.4	0.0	+0.4	nsec	
Input Data 1	tRIP1	tRCIP/7-0.4	tRCIP/7	tRCIP/7+0.4	nsec	
Input Data 2	tRIP2	2 × tRCIP/7-0.4	2 × tRCIP/7	2 × tRCIP/7+0.4	nsec	
Input Data 3	tRIP3	3 × tRCIP/7-0.4	3 × tRCIP/7	3 × tRCIP/7+0.4	nsec	
Input Data 4	tRIP4	4 × tRCIP/7-0.4	4 × tRCIP/7	4 × tRCIP/7+0.4	nsec	
Input Data 5	tRIP5	5 × tRCIP/7-0.4	5 × tRCIP/7	5 × tRCIP/7+0.4	nsec	
Input Data 6	tRIP6	6 × tRCIP/7-0.4	6 × tRCIP/7	6 × tRCIP/7+0.4	nsec	

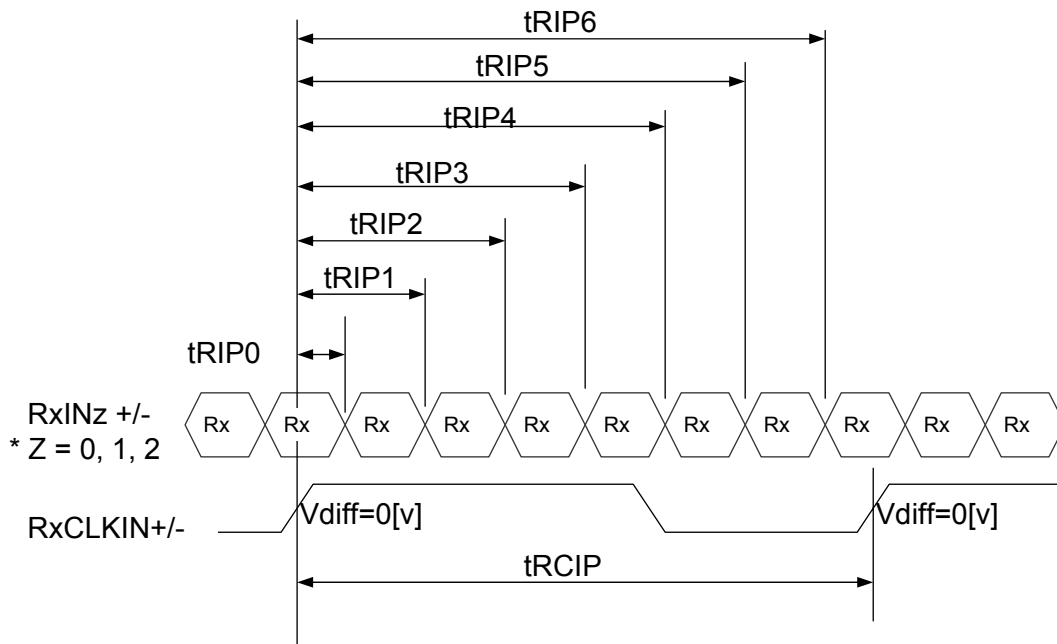



PRODUCT GROUP

REV

ISSUE DATE

TFT LCD PRODUCT

0

2011.07.06

### 6.0 INPUT SIGNALS, BASIC DISPLAY COLORS & GRAY SCALE OF COLORS

Each color is displayed in sixty-four gray scales from a 6 bit data signal input. A total of 262,144 colors are derived from the resultant 18 bit data.

Colors & Gray Scale		Red Data						Green Data						Blue Data					
		R5	R4	R3	R2	R1	R0	G5	G4	G3	G2	G1	G0	B5	B4	B3	B2	B1	B0
Basic Colors	Black	0	0	0	0	0	0	0	0	0	0	0	0	0	0	0	0	0	0
	Blue	0	0	0	0	0	0	0	0	0	0	0	0	1	1	1	1	1	1
	Green	0	0	0	0	0	0	1	1	1	1	1	1	0	0	0	0	0	0
	Cyan	0	0	0	0	0	0	1	1	1	1	1	1	1	1	1	1	1	1
	Red	1	1	1	1	1	1	0	0	0	0	0	0	0	0	0	0	0	0
	Magenta	1	1	1	1	1	1	0	0	0	0	0	0	1	1	1	1	1	1
	Yellow	1	1	1	1	1	1	1	1	1	1	1	1	0	0	0	0	0	0
	White	1	1	1	1	1	1	1	1	1	1	1	1	1	1	1	1	1	1
Gray Scale Of Red	Black	0	0	0	0	0	0	0	0	0	0	0	0	0	0	0	0	0	0
	△	0	0	0	0	0	1	0	0	0	0	0	0	0	0	0	0	0	0
	Darker	0	0	0	0	1	0	0	0	0	0	0	0	0	0	0	0	0	0
	△	↓						↓						↓					
	▽	↓						↓						↓					
	Brighter	1	1	1	1	0	1	0	0	0	0	0	0	0	0	0	0	0	0
▽	1	1	1	1	1	0	0	0	0	0	0	0	0	0	0	0	0	0	
Red	1	1	1	1	1	1	0	0	0	0	0	0	0	0	0	0	0	0	
Gray Scale Of Green	Black	0	0	0	0	0	0	0	0	0	0	0	0	0	0	0	0	0	0
	△	0	0	0	0	0	0	0	0	0	0	0	1	0	0	0	0	0	0
	Darker	0	0	0	0	0	0	0	0	0	0	1	0	0	0	0	0	0	0
	△	↓						↓						↓					
	▽	↓						↓						↓					
	Brighter	0	0	0	0	0	0	1	1	1	1	0	1	0	0	0	0	0	0
▽	0	0	0	0	0	0	1	1	1	1	1	0	0	0	0	0	0	0	
Green	0	0	0	0	0	0	1	1	1	1	1	1	0	0	0	0	0	0	
Gray Scale Of Blue	Black	0	0	0	0	0	0	0	0	0	0	0	0	0	0	0	0	0	0
	△	0	0	0	0	0	0	0	0	0	0	0	0	0	0	0	0	0	1
	Darker	0	0	0	0	0	0	0	0	0	0	0	0	0	0	0	0	0	1
	△	↓						↓						↓					
	▽	↓						↓						↓					
	Brighter	0	0	0	0	0	0	0	0	0	0	0	0	1	1	1	1	0	1
▽	0	0	0	0	0	0	0	0	0	0	0	0	1	1	1	1	1	0	
Blue	0	0	0	0	0	0	0	0	0	0	0	0	1	1	1	1	1	1	
Gray Scale Of White & Black	Black	0	0	0	0	0	0	0	0	0	0	0	0	0	0	0	0	0	0
	△	0	0	0	0	0	1	0	0	0	0	0	1	0	0	0	0	0	1
	Darker	0	0	0	0	1	0	0	0	0	0	1	0	0	0	0	0	1	0
	△	↓						↓						↓					
	▽	↓						↓						↓					
	Brighter	1	1	1	1	0	1	1	1	1	1	0	1	1	1	1	1	0	1
▽	1	1	1	1	1	0	1	1	1	1	1	0	1	1	1	1	1	0	
White	1	1	1	1	1	1	1	1	1	1	1	1	1	1	1	1	1	1	

SPEC. NUMBER  
S864-1443

SPEC TITLE  
HX121WX1-103 Product Specification

PAGE  
18 OF 32

## 7.0 POWER SEQUENCE

To prevent a latch-up or DC operation of the LCD module, the power on/off sequence shall be as shown in below

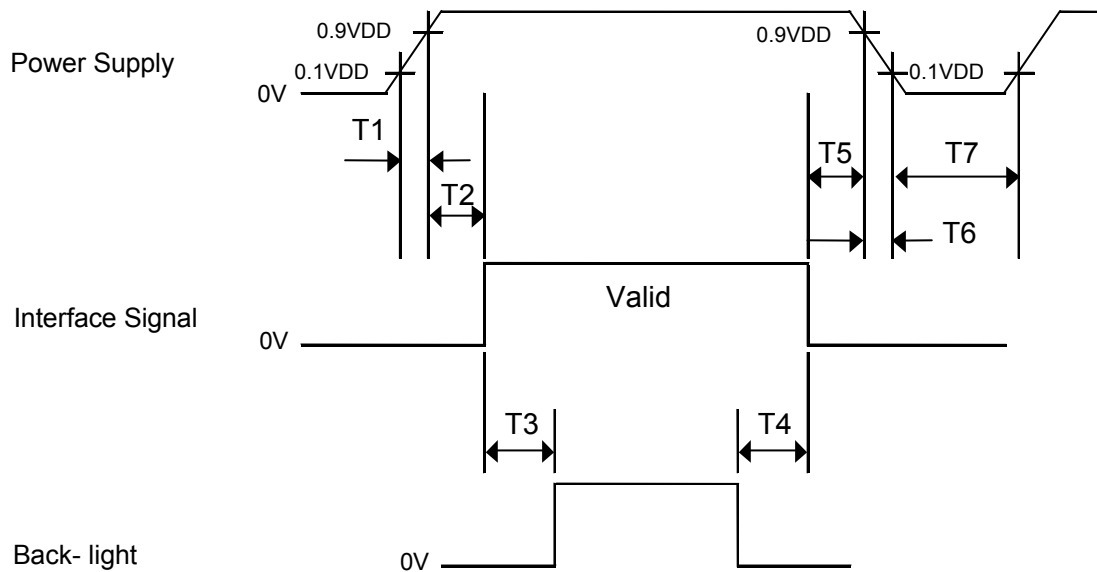

- $T1 \leq 10 \text{ ms}$
- $0 \leq T2 \leq 50 \text{ ms}$
- $200 \text{ ms} \leq T3$
- $200 \text{ ms} \leq T4$
- $0 \leq T5 \leq 50 \text{ ms}$
- $0 \leq T6 \leq 10 \text{ ms}$
- $500 \text{ ms} \leq T7$

Notes : 1. When the power supply VDD is 0V, Keep the level of input signals on the low or keep high impedance.

2. Do not keep the interface signal high impedance when power is on.

3. Back Light must be turn on after power for logic and interface signal are valid.

## 8.0 MECHANICAL CHARACTERISTICS

### 8.1 Dimensional Requirements

Figure 6 & 7 (located in 9.0) shows mechanical outlines for the model

Parameter	Specification	Unit
Active Area	261.12(H) X 163.20(V)	mm
Number of pixels	1280(H) X 800(V) (1 pixel = R + G + B dots)	
Pixel pitch	0.204(H) X 0.204(V)	
Pixel arrangement	RGB Vertical stripe	
Display colors	262,144	
Display mode	Normally Black	
Outline dimension	276.8 ± 0.3(H) × 180.0(V) ± 0.3 × 6.8(D:Max.)	mm
Weight	265(Typ.) / 275(Max.)	g
Back-light	SMD LED (48EA) Array	

### 8.2 Mounting

See Figure 6 & 7 & 8. (shown in 9.0)

Parameter	Specification	Unit
Torque of side mounting screw	2.5(Max.)	Kgf.cm <sup>2</sup>
Torque of ground plate screw	1.5(Max.)	Kgf.cm <sup>2</sup>
Torque of top side screw	2.5(Max.)	Kgf.cm <sup>2</sup>

### 8.3 Anti-Glare and Polarizer Hardness.

The surface of the LCD has an anti-glare coating to minimize reflection and a coating to reduce scratching.

### 8.4 Light Leakage

There shall not be visible light from the back-lighting system around the edges of the screen as seen from a distance 50cm from the screen with an overhead light level of 150lux. The manufacture shall furnish limit samples of the panel showing the light leakage acceptable.

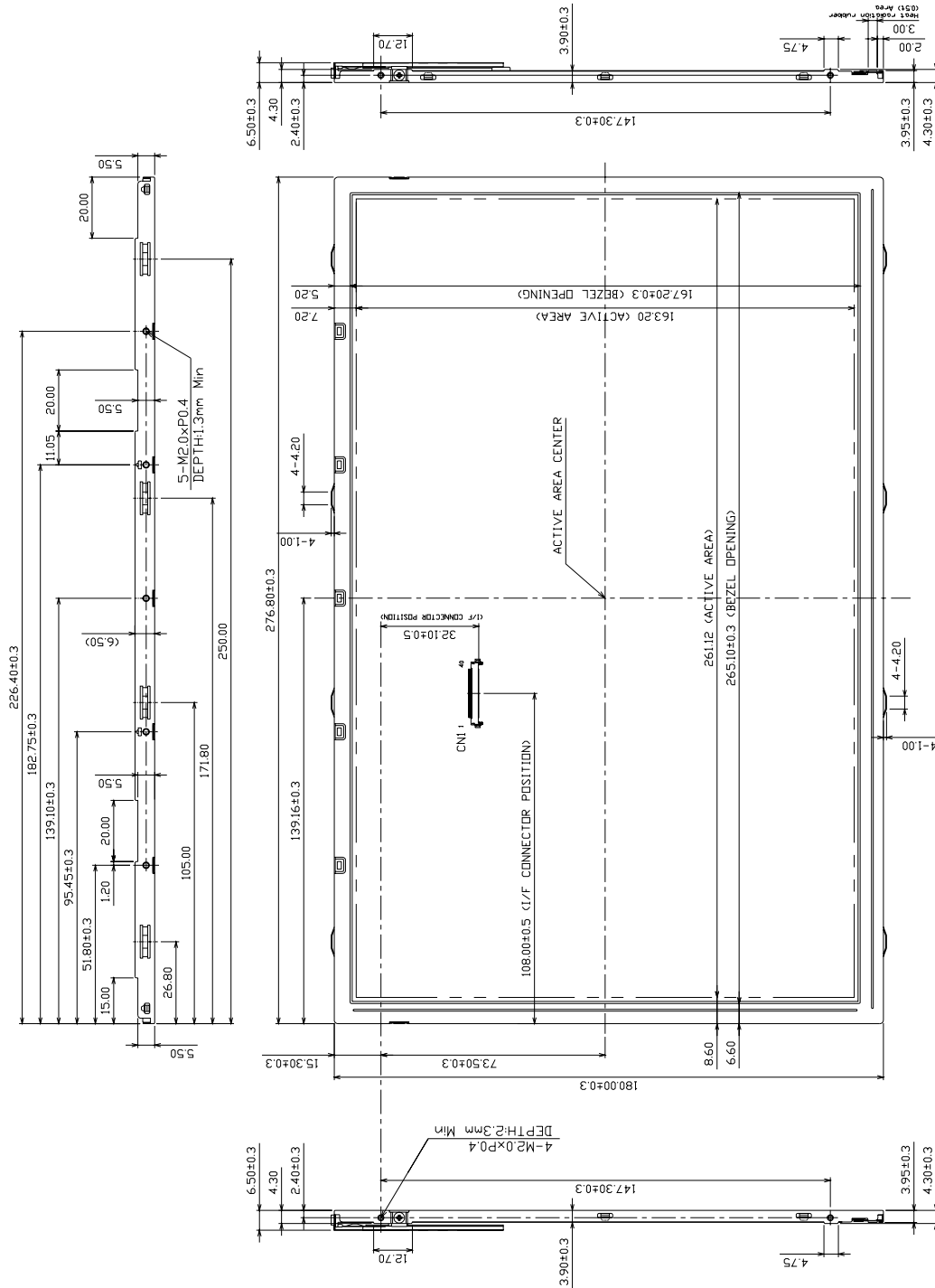
**9.0 Mechanical Drawing**
**Figure 6. TFT-LCD Module Outline Dimension (Front View)**

**SPEC. NUMBER**  
 S864-1443

**SPEC TITLE**  
 HX121WX1-103 Product Specification

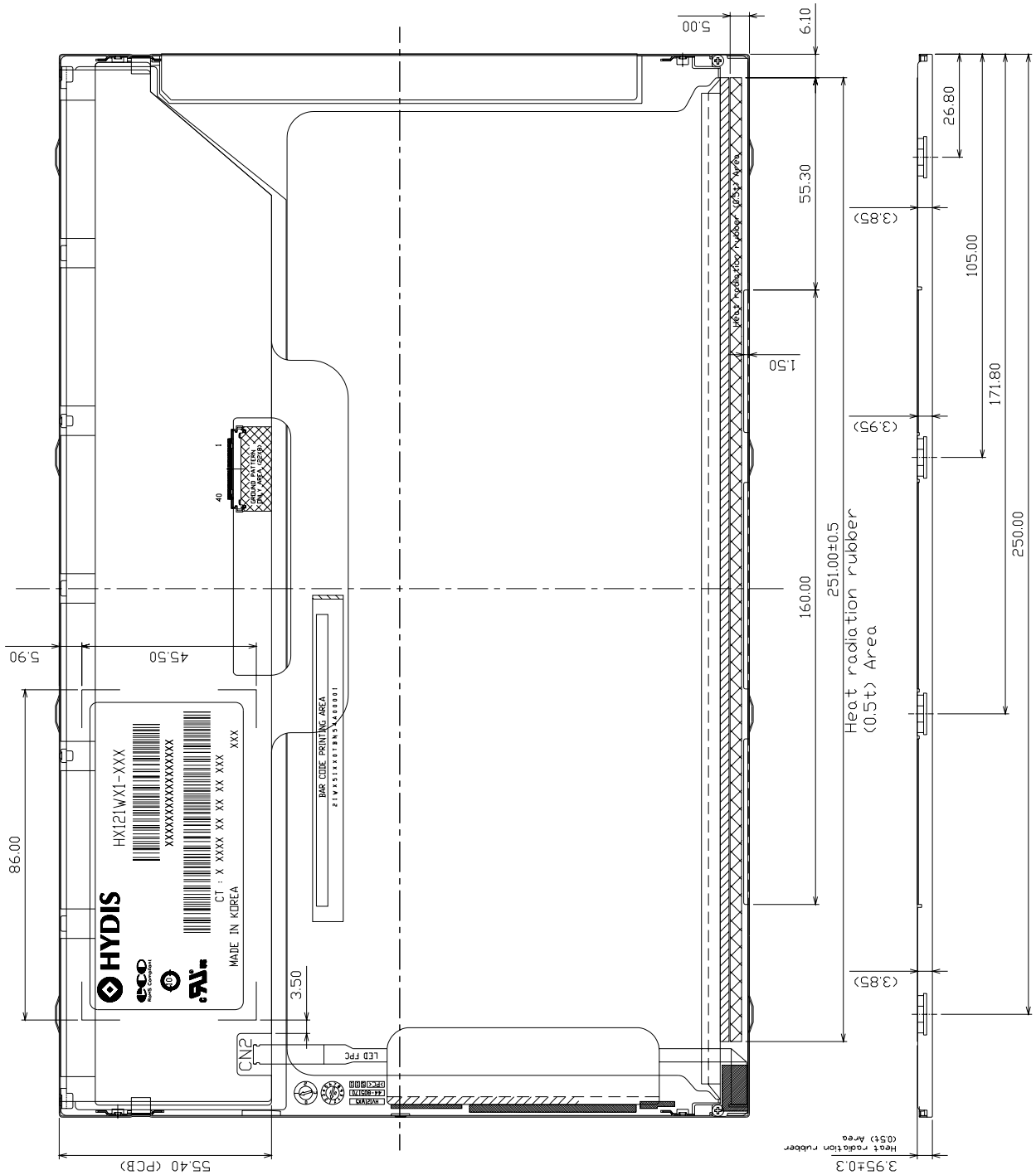
**PAGE**  
 21 OF 32

**Figure 7. TFT-LCD Module Outline Dimensions (Rear view)**

## 10.0 RELIABILITY TEST

The Reliability test items and its conditions are shown in below.

<Table 12. Reliability Test>

No	Test Item	Conditions
1	High temperature storage test	Ta = 60 °C, 240 hrs
2	Low temperature storage test	Ta = -20 °C, 240 hrs
3	High temperature & high humidity operation test	Ta = 50 °C, 80%RH, 240hrs
4	High temperature operation test	Ta = 50 °C, 240 hrs
5	Low temperature operation test	Ta = 0 °C, 240 hrs
6	Thermal shock	Ta = -20 °C ↔ 60 °C (30 min), 100 cycle
7	Vibration test (non-operating)	Frequency : 10~500Hz Gravity/AMP : 1.5G Period : X,Y,Z 30min
8	Shock test (non-operating)	Gravity : 220G Pulse width : 2ms, half sine wave ±X, ±Y, ±Z Once for each direction
9	Electro-static discharge test (non-operating)	Air : 150pF, 330ohm, 15KV Contact : 150pF, 330ohm, 8KV

## 11.0 HANDLING & CAUTIONS

### 11.1 Cautions when taking out the module

- Pick the pouch only, when taking out module from a shipping package.

### 11.2 Cautions for handling the module

- As the electrostatic discharges may break the LCD module, handle the LCD module with care. Peel a protection sheet off from the LCD panel surface as slowly as possible.
- As the LCD panel and back - light element are made from fragile glass (epoxy) material, impulse and pressure to the LCD module should be avoided.
- As the surface of the polarizer is very soft and easily scratched, use a soft dry cloth without chemicals for cleaning.
- Do not pull the interface connector in or out while the LCD module is operating.
- Put the module display side down on a flat horizontal plane.
- Handle connectors and cables with care.



**HYDIS**

PRODUCT GROUP

REV

ISSUE DATE

TFT LCD PRODUCT

0

2011.07.06

**11.3 Cautions for the operation**

- When the module is operating, do not lose MCLK, DE signals. If any one of these signals were lost, the LCD panel would be damaged.
- Obey the supply voltage sequence. If wrong sequence is applied, the module would be damaged.

**11.4 Cautions for the atmosphere**

- Dew drop atmosphere should be avoided.
- Do not store and/or operate the LCD module in a high temperature and/or humidity atmosphere. Storage in an electro-conductive polymer packing pouch and under relatively low temperature atmosphere is recommended.

**11.5 Cautions for the module characteristics**

- Do not apply fixed pattern data signal to the LCD module at product aging.
- Applying fixed pattern for a long time may cause image sticking.

**11.6 Cautions for the digitizer assembly**

- When assembling FPC connector, do not flip connector past 90° due to possible damage to connector.
- When positioning digitizer underneath driver IC, do not lift driver IC past 90° due to possible damage to drive IC pattern.
- Please be warned that during assembly of digitizer, the opening or closing of FPC will result in possible electrostatic discharge damage to the LED

**11.7 Other cautions**

- Do not re-adjust variable resistor or switch etc.
- When returning the module for repair or etc., Please pack the module not to be broken. We recommend to use the original shipping packages.

SPEC. NUMBER  
S864-1443

SPEC TITLE  
HX121WX1-103 Product Specification

PAGE  
24 OF 32





PRODUCT GROUP

REV

ISSUE DATE

TFT LCD PRODUCT

0

2011.07.06

### 12.0 LABELS

#### 12.1 Product Label



#### HYDIS Barcode

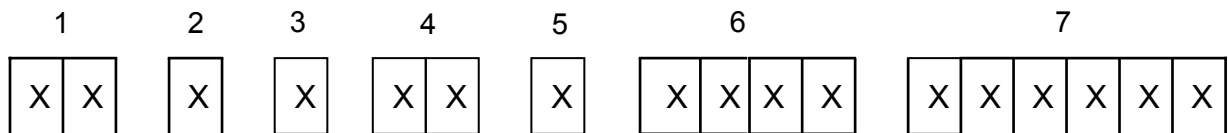

No 1. Control Number

No 2. Rank / Grade

No 3. Line Classification  
(HYDIS : H)

No 4. Year (5 : 2005, 6 : 2006, ...)

No 5. Month (1, 2, 3, ..., 9, X, Y, Z)

No 6. FG Code

No 7. Serial Number

SPEC. NUMBER  
S864-1443

SPEC TITLE  
HX121WX1-103 Product Specification

PAGE  
25 OF 32



PRODUCT GROUP

REV

ISSUE DATE

TFT LCD PRODUCT

0

2011.07.06

### 12.2 Packing Label

Label Size: 108 mm (L) × 56 mm (W)

Contents

Model: HX121WX1-103

Q`ty: Module Q`ty in one box

Serial No.: Box Serial No. See next figure for detail description.

Date: Packing Date

FG Code: FG Code of Product

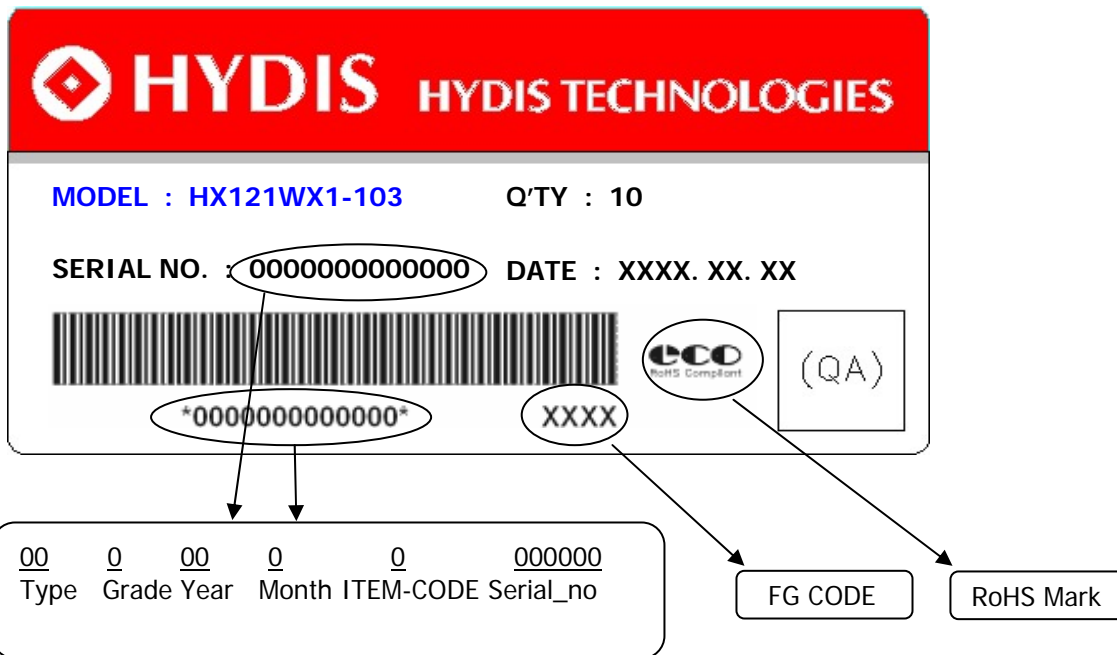

SPEC. NUMBER  
S864-1443

SPEC TITLE  
HX121WX1-103 Product Specification

PAGE  
26 OF 32

## 13.0 PACKING INFORMATION

### 13.1 Packing order

Put Pad into the box.

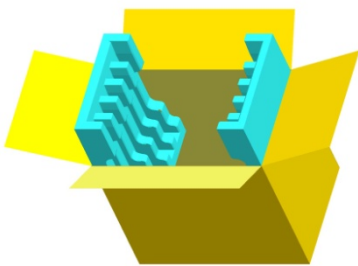

Put silica gels in the box.

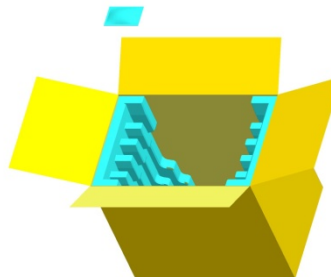

After sealing the box, attach Packing Label on the attach position sign area of the box.

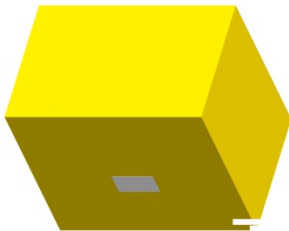

Place a cover on the top of the box.

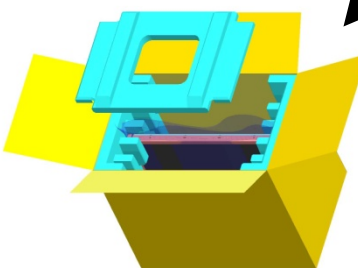

As shown in the figure, place the Modules bundled by shielding bag in the box.

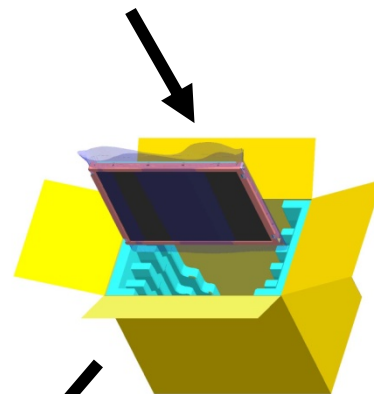

### 13.2 Notes

- Box Dimension : 349.0mm(W) X 261.0mm(D) X 311.0mm(H)
- Package Quantity in one Box : 10pcs

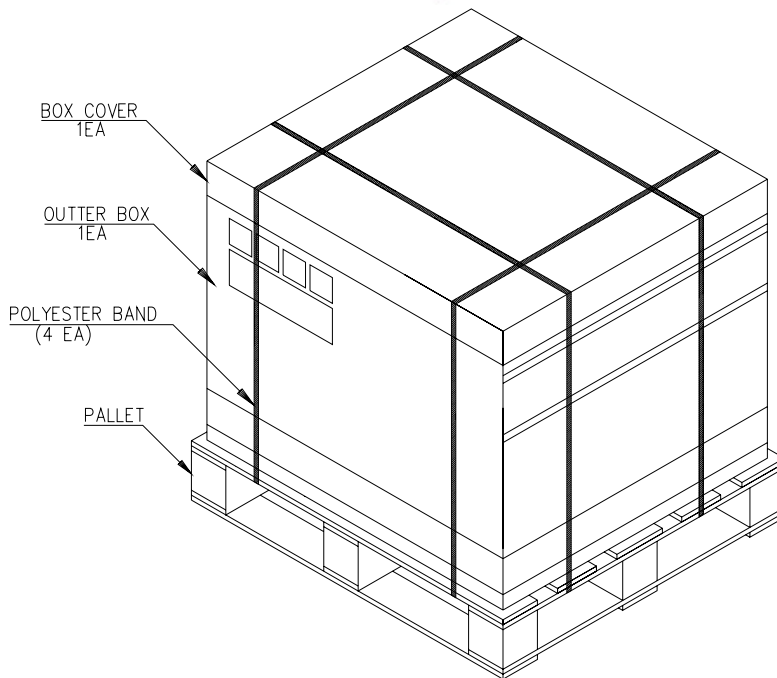
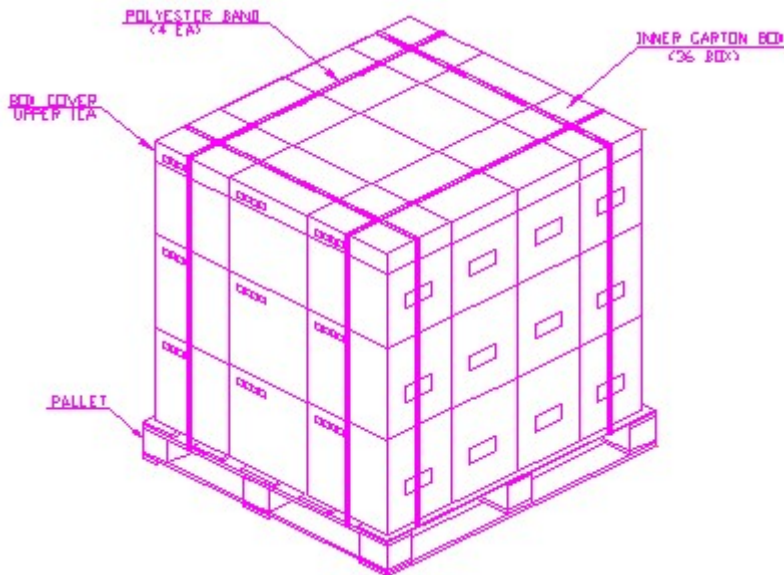
**13.2 Pallet Packing**

**\* Note**

- Pallet Dimension : : 1100 mm (L) × 1100 mm (W) × 120 mm (H)
- Package Quantity in one Box : 10pcs
- Box Quantity in one Pallet : 36 box



**PRODUCT GROUP**

REV

ISSUE DATE

TFT LCD PRODUCT

0

2011.07.06

**14.0 EDID Table**

Address (HEX)	Function	Hex	Dec	values.	Notes
00	Header	00	0	0	EDID Header
01		FF	255	255	
02		FF	255	255	
03		FF	255	255	
04		FF	255	255	
05		FF	255	255	
06		FF	255	255	
07		00	0	0	
08	ID Manufacturer Name	09	9	BOE	ID = BOE
09		E5	229		
0A	ID Product Code	A0	160	2208	ID = 2208
0B		08	8		
0C	32-bit serial No.	00	0		
0D		00	0		
0E		00	0		
0F		00	0		
10	Week of manufacture	0	0	0	
11	Year of Manufacture	14	20	2010	Manufactured in 2010
12	EDID Structure Ver.	01	1	1	EDID Ver 1.0
13	EDID revision #	04	4	4	EDID Rev. 0.4
14	Video input definition	95	149	-	Refer to right table
15	Max H image size	1A	26	26	26 cm (Approx)
16	Max V image size	10	16	16	16 cm (Approx)
17	Display Gamma	78	120	2.2	Gamma curve = 2.2
18	Feature support	2A	42		RGB display, Preferred Timming mode
19	Red/Green low bits	92	146	-	Red / Green Low Bits
1A	Blue/White low bits	75	117	-	Blue / White Low Bits
1B	Red x high bits	90	144	0.564	Red (x) = 10010000 (0.56416)
1C	Red y high bits	59	89	0.349	Red (y) = 01011001 (0.3491)
1D	Green x high bits	5A	90	0.352	Green (x) = 01011010 (0.35152)
1E	Green y high bits	90	144	0.565	Green (y) = 10010000 (0.5648)
1F	Blue x high bits	26	38	0.150	Blue (x) = 00100110 (0.14956)
20	Blue y high bits	1D	29	0.117	Blue (y) = 00011101 (0.1166)
21	White x high bits	50	80	0.313	White (x) = 01010000 (0.313)
22	White y high bits	54	84	0.329	White (y) = 01010100 (0.329)

SPEC. NUMBER  
S864-1443

SPEC TITLE  
HX121WX1-103 Product Specification

PAGE  
29 OF 32



PRODUCT GROUP

REV

ISSUE DATE

TFT LCD PRODUCT

0

2011.07.06

Address (HEX)	Function	Hex	Dec	values.	Notes
23	Established timing 1	00	0	-	Refer to right table
24	Established timing 2	00	0	-	
25	Established timing 3	00	0	-	
26	Standard timing #1	01	1		Not Used
27		01	1		
28	Standard timing #2	01	1		Not Used
29		01	1		
2A	Standard timing #3	01	1		Not Used
2B		01	1		
2C	Standard timing #4	01	1		Not Used
2D		01	1		
2E	Standard timing #5	01	1		Not Used
2F		01	1		
30	Standard timing #6	01	1		Not Used
31		01	1		
32	Standard timing #7	01	1		Not Used
33		01	1		
34	Standard timing #8	01	1		Not Used
35		01	1		
36	Detailed timing/monitor descriptor #1	12	18	69.3000	69.3MHz Main clock
37		1B	27		
38		00	0	1280	Hor Active = 1280
39		8A	138	138	Hor Blanking = 138
3A		50	80	-	4 bits of Hor. Active + 4 bits of Hor. Blanking
3B		20	32	800	Ver Active = 800
3C		0E	14	14	Ver Blanking = 14
3D		30	48	-	4 bits of Ver. Active + 4 bits of Ver. Blanking
3E		1A	26	26	Hor Sync Offset = 26
3F		16	22	22	H Sync Pulse Width = 22
40		22	34	2	V sync Offset = 2 line
41		00	0	2	V Sync Pulse width : 2 line
42		05	5	261	Horizontal Image Size = 261 mm (Low 8 bits)
43		A3	163	163	Vertical Image Size = 163 mm (Low 8 bits)
44		10	16	-	4 bits of Hor Image Size + 4 bits of Ver Image Size
45		00	0	0	Hor Border (pixels)
46		00	0	0	Vertical Border (Lines)
47		19	25	-	Refer to right table

SPEC. NUMBER  
S864-1443

SPEC TITLE  
HX121WX1-103 Product Specification

PAGE  
30 OF 32



PRODUCT GROUP

REV

ISSUE DATE

TFT LCD PRODUCT

0

2011.07.06

Address (HEX)	Function	Hex	Dec	values.	Notes
48	Detailed timing/monitor descriptor #2 (sDRRS 40Hz)	0C	12	46.2000	
49		12	18		
4A		0	0	1280	
4B		8A	138	138	
4C		50	80	-	
4D		20	32	800	
4E		0E	14	14	
4F		30	48	-	
50		1A	26	26	
51		16	22	22	
52		22	34	2	
53		00	0	2	
54		05	5	261	
55		A3	163	163	
56		10	16	-	
57		00	0	0	
58		00	0	0	
59	19	25	-		
5A	Detailed timing/monitor descriptor #3 (nVDPS)	00	0	0	
5B		00	0	0	
5C		00	0	0	
5D		00	0	0	
5E		00	0	0	
5F		00	0	0	
60		00	0	0	
61		00	0	0	
62		00	0	0	
63		00	0	0	
64		00	0	0	
65		00	0	0	
66		00	0	0	
67		00	0	0	
68		00	0	0	
69	00	0	0		
6A	00	0	0		
6B	00	0	0		

SPEC. NUMBER  
S864-1443

SPEC TITLE  
HX121WX1-103 Product Specification

PAGE  
31 OF 32



PRODUCT GROUP

REV

ISSUE DATE

TFT LCD PRODUCT

0

2011.07.06

Address (HEX)	Function	Hex	Dec	values.	Notes	
6C	Detailed timing/monitor descriptor #4 (Brightness Table)	00	0	0	Detailed Timing Description #4	
6D		00	0	0	Flag	
6E		00	0	0	Reserved	
6F		02	2	2	For Brightness Table and Power consumption	
70		00	0	0	Flag	
71		19	25	-	PWM 10% [7:0] @ Step 0	
72		33	51	-	PWM 20% [7:0] @ Step 5	
73		FF	255	-	PWM 100% [7:0] @ Step 10	
74		1E	30	-	30Nits [7:0] @ Step 0	
75		3C	60	-	60Nits [7:0] @ Step 5	
76		96	150	-	300Nits [7:0] @ Step 10	
77		19	25	1000	Panel Electronics Power @32x32 Chess Pattern	
78		14	20	800	Backlight Power @60 nits	
79		22	34	2740	Backlight Power @Step 10	
7A		96	150	300	Nits @ 100% PWM Duty	
7B		00	0	0	Flags	
7C		00	0	0	Flags	
7D		00	0	0	Flags	
7E		Extension flag	00	0	0	
7F		Checksum	02	2	-	

※ Note : Brightness of EDID table is center 1point value.

SPEC. NUMBER  
S864-1443

SPEC TITLE  
HX121WX1-103 Product Specification

PAGE  
32 OF 32