



**PROPRIETARY NOTE**

THIS SPECIFICATION IS THE PROPERTY OF HYDIS AND SHALL NOT BE REPRODUCED OR COPIED WITHOUT THE WRITTEN PERMISSION OF HYDIS AND MUST BE RETURNED TO HYDIS UPON ITS REQUEST

# **TITLE : HV070WS1-105**

## **Product Specification**

**HYDIS Technologies**

<b>SPEC. NUMBER</b> S864-1470	<b>PRODUCT GROUP</b> TFT LCD	<b>REV.</b> A	<b>ISSUE DATE</b> 2012.06.25	<b>PAGE</b> 1 OF 34
----------------------------------	---------------------------------	------------------	---------------------------------	------------------------



## Contents

No	Item	Page
1.0	General Description	4
2.0	Absolute Maximum Ratings	6
3.0	Electrical Specifications	7
4.0	Optical Specifications	8
5.0	Interface Connections	13
6.0	Signal Timing Specifications	16
7.0	Signal Timing Waveforms	16
8.0	Input Signals, Basic Display Colors & Gray Scale of Colors	19
9.0	3-Wire Special Port Interface (SPI Interface)	19
10.0	Power Sequence	26
11.0	Mechanical Characteristics	27
12.0	Mechanical Drawing	28
13.0	Reliability Test	30
14.0	Handling & Cautions	31
15.0	Labels	32
16.0	Packing Information	34

## 1.0 GENERAL DESCRIPTION

### 1.1 Introduction

HV070WS1-105 is a color active matrix TFT LCD module using amorphous silicon TFT's (Thin Film Transistors) as an active switching devices. This module has a 7.01 inch diagonally measured active area with WSVGA resolutions (1024 horizontal by 600 vertical pixel array). Each pixel is divided into RED, GREEN, BLUE dots which are arranged in vertical Stripe and this module can display 16.7M colors. The TFT-LCD panel used for this module is a low reflection and higher color type.

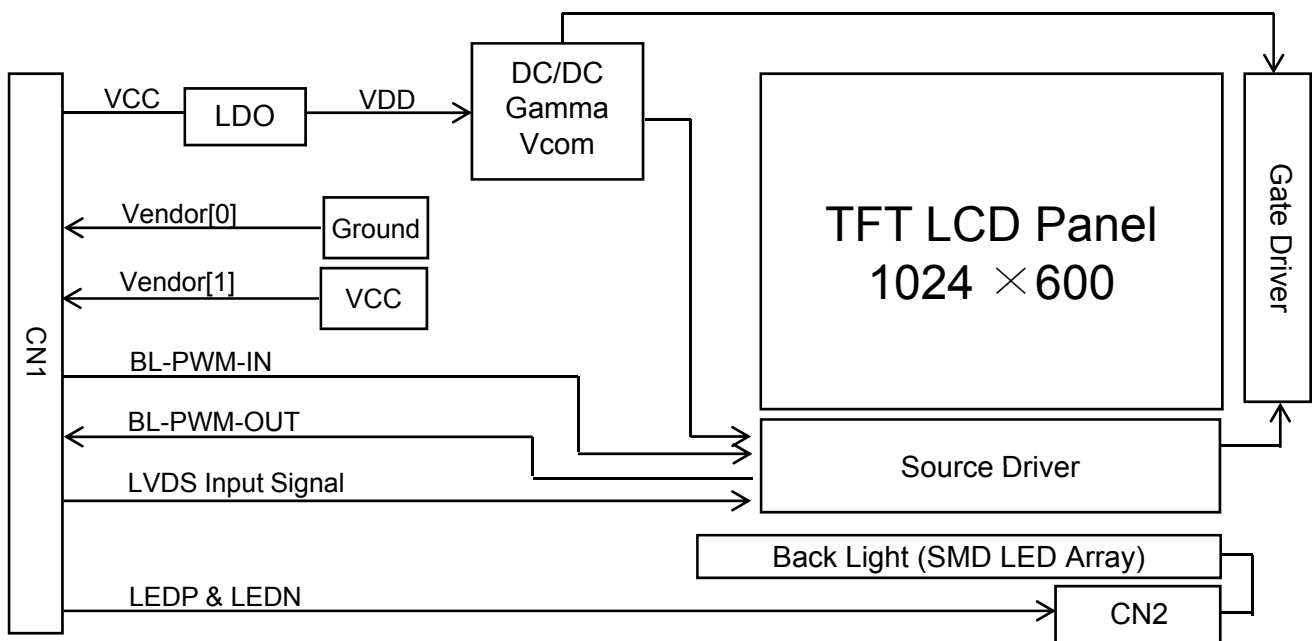

### 1.2 Features

- FAB site : Hydis Korea
- Thin and Light Weight
- 3.3 V Logic Power & 16 V Back-light power Supply
- 1 Channel LVDS Interface
- SMD LED (20EA) Array (Bottom Side/Horizontal Direction)
- 16.7M Colors (With Dither & HFRC)
- Need SPI control (CSB, SCL, SDA) for module driving
- Green Product (RoHS) & Halogen free



# HYDIS

PRODUCT GROUP

REV

ISSUE DATE

TFT LCD PRODUCT

0

2012.06.25

### 1.3 Application

- E-book, etc

### 1.4 General Specifications

< Table 1. General Specifications >

Parameter	Specification	Unit	Remark
Active area	153.6(H) × 90.0(V)	mm	
Number of pixels	1024(H) × 600(V)	pixels	
Pixel pitch	0.15(H) × 0.15(V)	mm	
Pixel arrangement	RGB Vertical Stripe		
Display colors	16.7M	colors	Note 1
Display mode	Normally Black		
Outline dimension	163.6±0.3(H) × 102.9±0.3(V) × 2.47±0.2(D)	mm	Note 2
Weight	95 (Max.)	g	
Back-light	Bottom edge side, 20-LEDs type		

Note 1 : Support 16.7M with dither and HFRC

Note 2 : Without component

Horizontal outline dimension is some different to customer request which is

162.8±0.3(H) × 102.9±0.3(V) × 2.47±0.2(D)

But outline dimension is confirm value between Hydis and Customer

SPEC. NUMBER  
S864-1470

SPEC TITLE  
HV070WS1-105 Product Specification

PAGE  
5 OF 34

## 2.0 ABSOLUTE MAXIMUM RATINGS

The followings are maximum values which, if exceed, may cause faulty operation or damage to the unit.

< Table 2. Absolute Maximum Ratings >

Ta=25+/-2°C

Parameter	Symbol	Min.	Max.	Unit	Remarks
Logic Power Supply Voltage	V <sub>CC</sub>	-0.3	V <sub>CC</sub> +0.3	V	
Back-light Power Supply Voltage	V <sub>L</sub>	-0.3	40	V	
Back-light LED Current	I <sub>L</sub>	-	30	mA	Note 1
Back-light LED Reverse Voltage	V <sub>R</sub>	-	5	V	
Operating Temperature	T <sub>OP</sub>	-20	+60	°C	Note 1,
Storage Temperature	T <sub>SP</sub>	-40	+70	°C	Note 2

Note 1. Ambient temperature vs allowable forward current are shown in the figure below.

Note 2. Temperature and relative humidity range are shown in the figure below.

90% RH Max. ( 40°C ≥ Ta)

Maximum wet - bulb temperature at 39°C or less. ( > 40°C ) No condensation.

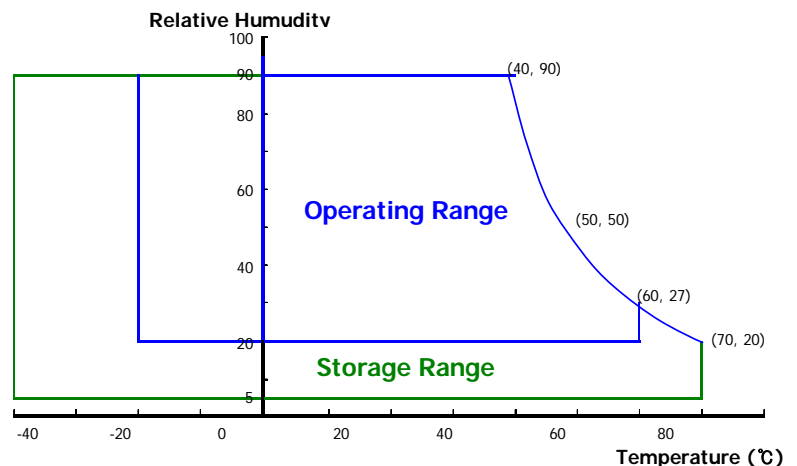
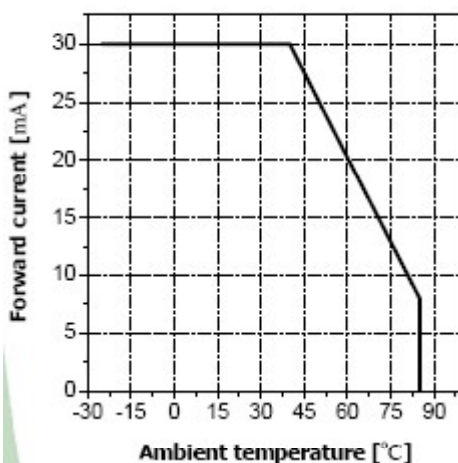

### 3.0 ELECTRICAL SPECIFICATIONS

#### 3.1 Electrical Specifications

< Table 3. Electrical Specifications >

Parameter		Min.	Typ.	Max.	Unit	Remarks
Logic Power Supply Voltage	$V_{CC}$	3.0	3.3	3.6	V	Note 1
Logic Power Supply Current	$I_{CC}$	-	220	270	mA	
Logic Power Consumption	$P_C$		0.73	0.89	W	
Back-light Power Supply Voltage	$V_L$	-	16	17	V	Note 2
Back-light Power Supply Current	$I_L$	-	20	25	mA	
Back-light Power Consumption	$P_{BL}$	-	1.28	1.36	W	Note 2, 4
High Level Differential Input Signal ( $V_{CM} = 1.2V$ )	$V_{TH}$	-	-	0.1	V	LVDS input
Low Level Differential Input Signal	$V_{TL}$	-0.1	-	-	V	
Input voltage range (singled-end)	$V_{IN}$	0	-	2.4	V	
Differential input voltage	$ V_{ID} $	0.1	-	0.6	V	
Differential input common mode voltage	$V_{CM}$	$( V_{ID} /2)$		$2.4 - ( V_{ID} /2)$	V	
Input Current	$V_{IN}$	-10	-	-10	$\mu A$	
Panel unit life time		50,000	-	-	Hrs	Without BL,PCB
Total Power Consumption	$P_{total}$	-	2.01	2.25	W	Note 1,2,4

- Notes : 1. The supply voltage is measured and specified at the interface connector of LCM.  
 The logic current draw and power consumption specified is for 3.3V at 25°C.  
 a) Typ : Window XP pattern,      b) Max : White pattern
2. The supply voltage is measured and specified at the interface connector of LCM.  
 The Backlight current draw and power consumption specified is 16V at 25°C.  
 The voltage and current value means value for chain.
3. PWM frequency and voltage level is fixed by customer.
4. Backlight power consumption is calculated value for reference ( $V_L \times I_L \times 4$  chains).  
 About maximum power of backlight is  $17V \times 20mA \times 4$  chains = 1.36W

## 4.0 OPTICAL SPECIFICATIONS

### 4.1 Overview

The test of optical specifications shall be measured in a dark room (ambient luminance  $\leq 1$  lux and temperature =  $25 \pm 2^\circ\text{C}$ ) with the equipment of Luminance meter system (Goniometer system and TOPCON BM-5A) and test unit shall be located at an approximate distance 50cm from the LCD surface at a viewing angle of  $\theta$  and  $\Phi$  equal to  $0^\circ$ . We refer to  $\theta_{\Phi=0}$  ( $=\theta_3$ ) as the 3 o'clock direction (the "right"),  $\theta_{\Phi=90}$  ( $=\theta_{12}$ ) as the 12 o'clock direction ("upward"),  $\theta_{\Phi=180}$  ( $=\theta_9$ ) as the 9 o'clock direction ("left") and  $\theta_{\Phi=270}$  ( $=\theta_6$ ) as the 6 o'clock direction ("bottom"). While scanning  $\theta$  and/or  $\Phi$ , the center of the measuring spot on the Display surface shall stay fixed.  $V_{CC}$  shall be  $3.3 \pm 0.3\text{V}$  at  $25^\circ\text{C}$ .

### 4.2 Optical Specifications

<Table 4. Optical Specifications>

Parameter		Symbol	Condition	Min.	Typ.	Max.	Unit	Remarks
Viewing Angle range	Horizontal	$\Theta_3$	CR > 10	75	85		Deg.	Note 1
		$\Theta_9$		75	85		Deg.	
	Vertical	$\Theta_{12}$		75	85		Deg.	
		$\Theta_6$		75	85		Deg.	
Luminance Contrast ratio		CR	$\Theta = 0^\circ$	640	800	-		Note 2
Luminance of White	1 Points	$Y_w$	$\Theta = 0^\circ$		30		cd/m <sup>2</sup>	Note 4
				340	400	-	cd/m <sup>2</sup>	
White Luminance uniformity	9 Points	$\Delta Y_9$		72	80	-	%	Note 5
				White Chromaticity		$\Theta = 0^\circ$	0.280	0.301
	$W_x$	0.310	0.330	0.370				
Reproduction of color	Red	$R_x$	0.563	0.593	0.623			
		$R_y$	0.323	0.353	0.383			
	Green	$G_x$	0.283	0.313	0.343			
		$G_y$	0.559	0.589	0.619			
	Blue	$B_x$	0.121	0.151	0.181			
		$B_y$	0.099	0.129	0.159			
Response Time		Total ( $T_r + T_d$ )	$T_a = 25^\circ\text{C}$ $\Theta = 0^\circ$	-	50	-	ms	Note 6
Cross Talk		CT	$\Theta = 0^\circ$	-	-	2.0	%	Note 7





**HYDIS**

PRODUCT GROUP

REV

ISSUE DATE

TFT LCD PRODUCT

0

2012.06.25

Notes :

1. Viewing angle is the angle at which the contrast ratio is greater than 10. The viewing angles are determined for the horizontal or 3, 9 o'clock direction and the vertical or 6, 12 o'clock direction with respect to the optical axis which is normal to the LCD surface (see Figure1).

2. Contrast measurements shall be made at viewing angle of  $\Theta = 0$  and at the center of the LCD surface. Luminance shall be measured with all pixels in the view field set first to white, then to the dark (black) state (see Figure1). Luminance Contrast Ratio (CR) is defined mathematically as  $CR = \text{Luminance when displaying a white raster} / \text{Luminance when displaying a black raster}$ .

3. Reference only / Standard Front Surface Treatment Measured with green cover glass. The color chromaticity coordinates specified in Table 4 shall be calculated from the spectral data measured with all pixels first in red, green, blue and white. Measurements shall be made at the center of the panel.

4. The luminance value of 400 cd/m<sup>2</sup> means the brightness of PWM is 100%. The luminance value of 30 cd/m<sup>2</sup> means the brightness of lower PWM. CTF means that measure brightness at only center point at Figure 2.

SPEC. NUMBER  
S864-1470

SPEC TITLE  
HV070WS1-105 Product Specification

PAGE  
9 OF 34

### 4.3 Optical Measurements

**Figure 1. Measurement Set Up**

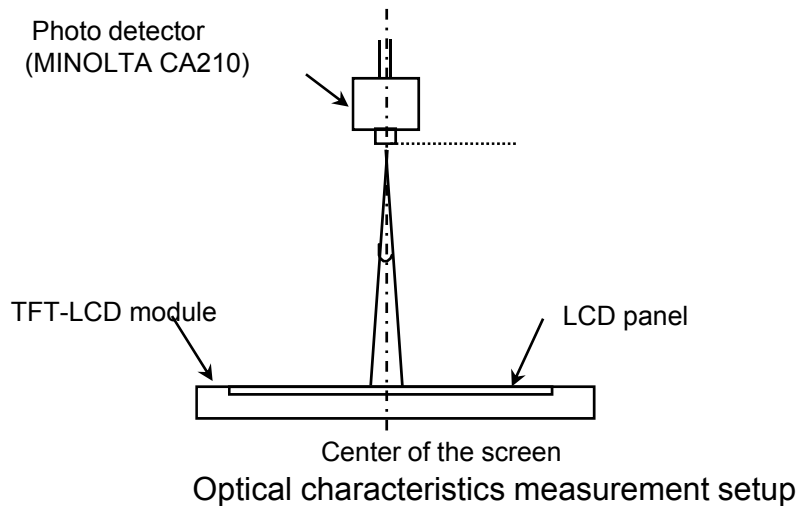

**Figure 2. Uniformity Measurement Locations (9 points)**

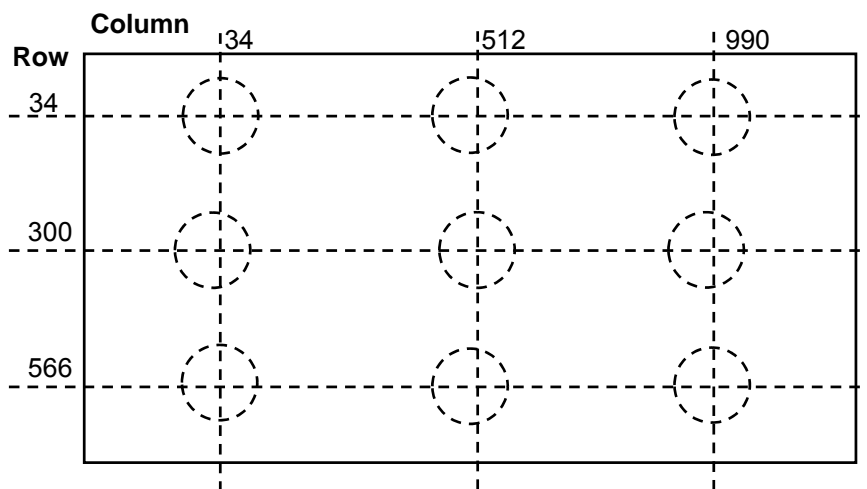

Note 5.

The White luminance uniformity on LCD surface is then expressed as :

$\Delta Y = ( \text{Minimum Luminance of 9 points} / \text{Maximum Luminance of 9 points} ) * 100$  Refer Figure 2 about measurement points

\* LED Condition = (Duty Ratio 100%, LED current 20mA)

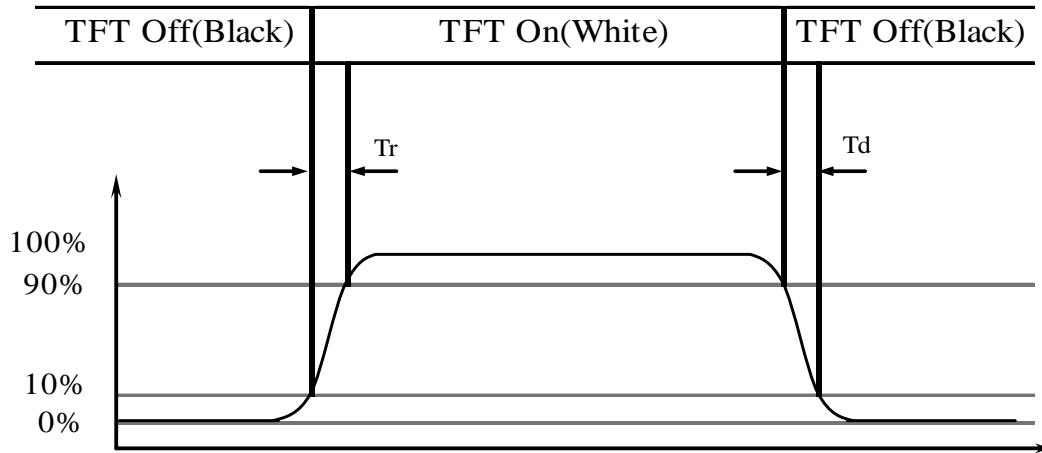
**Figure 3. Response Time Testing**

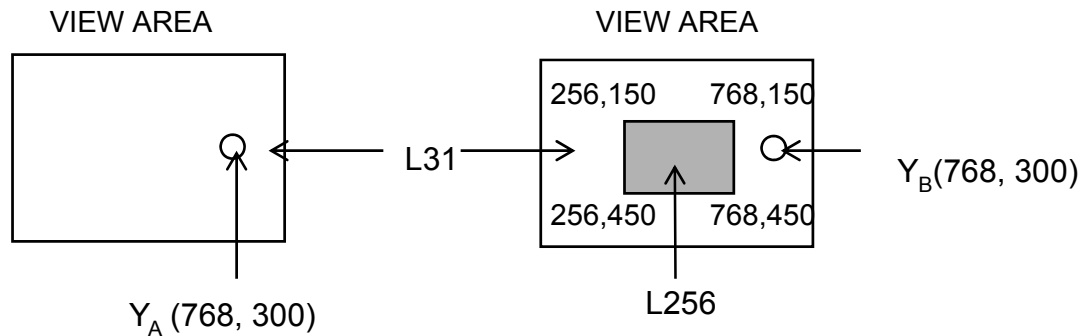
**Figure 4. Cross Modulation Test Description**

$$\text{Cross-Talk (\%)} = \left| \frac{Y_B - Y_A}{Y_B} \right| \times 100$$

Where:

$Y_A$  = Initial luminance of measured area (cd/m<sup>2</sup>)

$Y_B$  = Subsequent luminance of measured area (cd/m<sup>2</sup>)

The location measured will be exactly the same in both patterns

Note 6.

The electro-optical response time measurements shall be made as Figure 3 by switching the "data" input signal ON and OFF. The times needed for the luminance to change from 10% to 90% is Tr, and 90% to 10% is Td.

Note 7.

Cross-Talk of one area of the LCD surface by another shall be measured by comparing the luminance ( $Y_A$ ) of a 25mm diameter area, with all display pixels set to a gray level, to the luminance ( $Y_B$ ) of that same area when any adjacent area is driven dark (Refer to Figure 4).

**HYDIS**

PRODUCT GROUP

REV

ISSUE DATE

TFT LCD PRODUCT

O

2012.06.25

**5.0 INTERFACE CONNECTIONS****5.1 Electrical Interface Connection****CN1 Interface Connector (DF23C-30DS-0.5V(51), Manufacture by HIROSE)**

&lt;Table 5, Electrical Interface Connection &gt;

Pin No.	Symbol	Function	Pin No.	Symbol	Function
1	VCC	+3.3V Power Supply	16	D1-IN-N	LDVS differential data input
2	GND	Ground	17	Vendor[1]	Vendor distinguish pin 2
3	VCC	+3.3V Power Supply	18	D1-IN-P	LDVS differential data input
4	CLK-IN-N	LVDS Clock input (Negative)	19	CSB	Serial Communication Chip Select
5	VCC	+3.3V Power Supply	20	GND	Ground
6	CLK-IN-P	LVDS Clock input (Positive)	21	SCL	Serial Communication Clock Input
7	GND	Ground	22	D2-IN-N	LDVS differential data input
8	GND	Ground	23	SDA	Serial Communication Data Input
9	LEDP	Power supply for LED [Anode]	24	D2-IN-P	LDVS differential data input
10	D0-IN-N	LDVS differential data input	25	GND	Ground
11	LEDN	Power supply for LED [Cathode]	26	GND	Ground
12	D0-IN-P	LDVS differential data input	27	BL-PWM-IN	Brightness Control Signal
13	GND	Ground	28	D3-IN-N	LDVS differential data input
14	GND	Ground	29	BL-PWM-OUT	Backlight Dimmer Signal
15	Vendor[0]	Vendor distinguish pin 1	30	D3-IN-P	LDVS differential data input

SPEC. NUMBER  
S864-1470SPEC TITLE  
HV070WS1-105 Product SpecificationPAGE  
13 OF 34

**5.2 LVDS Interface**
**LVDS Transmitter : THC63LVDM83A**

&lt;Table 6, LVDS Interface &gt;

Input signal	Transmitter		Interface		AA01B-P030VA1	Remark
	Pin No	Pin No	System (Tx)	TFT-LCD (Rx)	Pin No.	
R0	51	48 47	OUT0- OUT0+	D0-IN-N D0-IN-P	10 12	
R1	52					
R2	54					
R3	55					
R4	56					
R5	3					
G0	4	46 45	OUT1- OUT1+	D1-IN-N D1-IN-P	16 18	
G1	6					
G2	7					
G3	11					
G4	12					
G5	14					
B0	15	42 41	OUT2- OUT2+	D2-IN-N D2-IN-P	22 24	
B1	19					
B2	20					
B3	22					
B4	23					
B5	24					
HSYNC	27	38 37	OUT3- OUT3+	D3-IN-N D3-IN-P	28 30	
VSYNC	28					
DE	30					
R6	50					
R7	2					
G6	8					
G7	10	40	CLKOUT-	CLK-IN-N	4	
B6	16					
B7	18	39	CLKOUT+	CLK-IN-P	6	
Reserved	25					
MCLK	31					

### 5.3 Back-light Interface

CN2 LED FPC Connector ( solder type )

<Table 7, LED FPC connection >

Pin No.	Symbol	Function	Remark
1	Anode1	LED Anode Power Supply	Typ. 16V
2			
3	Cathode1	LED Cathode Power Supply	
4		LED Cathode Power Supply	

### 5.4 Data Input Format

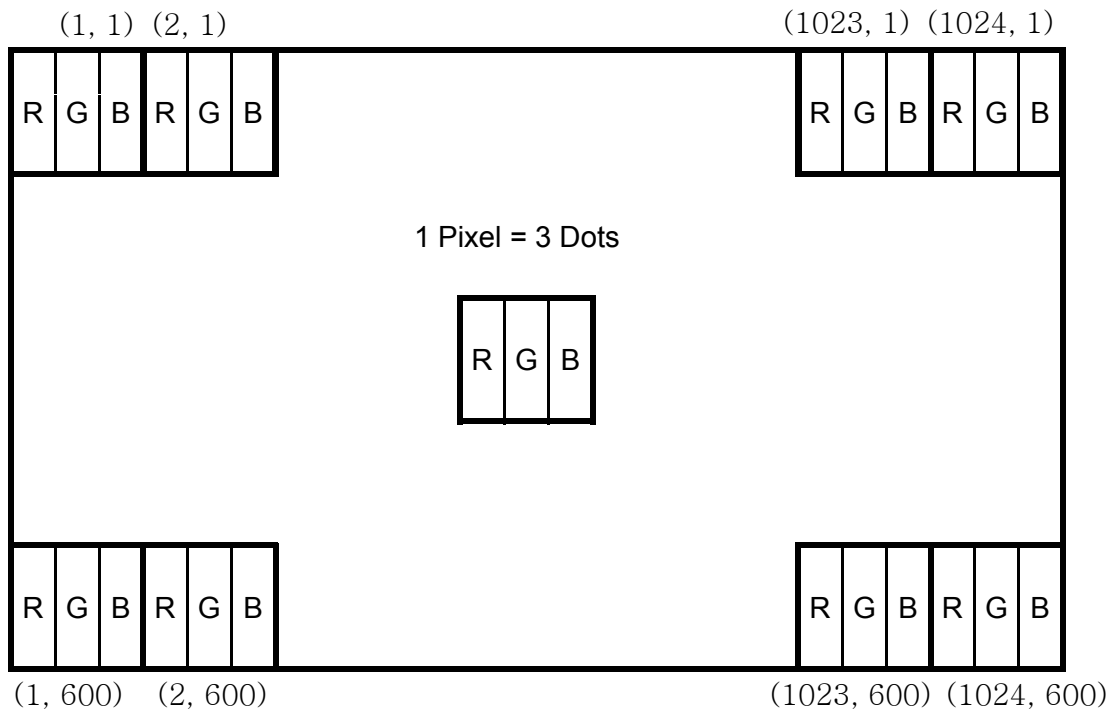

## 6.0. SIGNAL TIMING SPECIFICATIONS

### 6.1 Timing specification at HV Mode (LVDS Transmitter Input)

<Table 8, Signal Timing >

Item	Symbol	Min.	Typ.	Max.	Unit
Frame Rate	-	40	60	73	Hz
Frame Period	T1	624	635	750	Lines
Vertical Display Time	T2	-	600	-	Lines
Vertical Blanking Time	T3	-	35	-	Lines
1 Line Scanning Time	T4	1200	1344	1400	Clocks
Horizontal Display Time	T5	-	1024	-	Clocks
Horizontal Blanking Time	T6	-	320	-	Clocks
Clock Rate	1/T7	40.8	51.2	63	MHz

## 7.0 SIGNAL TIMING WAVEFORMS

### 7.1 Vertical Input Timing Waveforms of Interface Signal

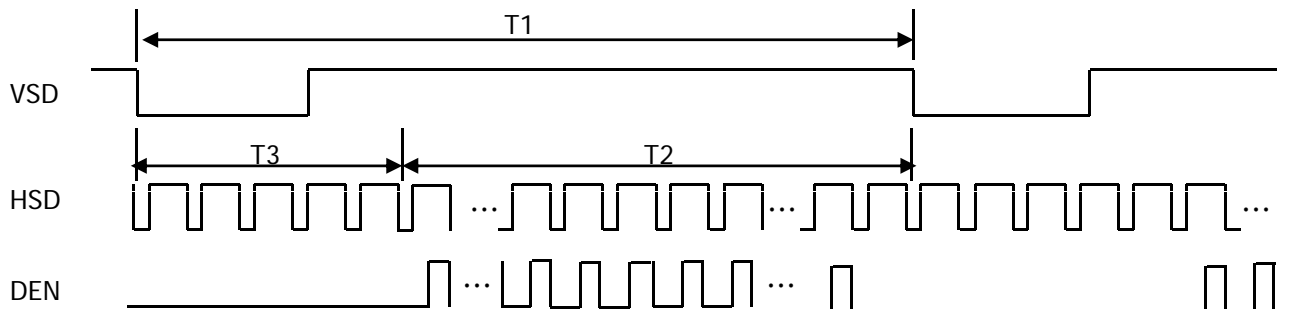

### 7.2 Horizontal Input Timing Waveforms of Interface Signal

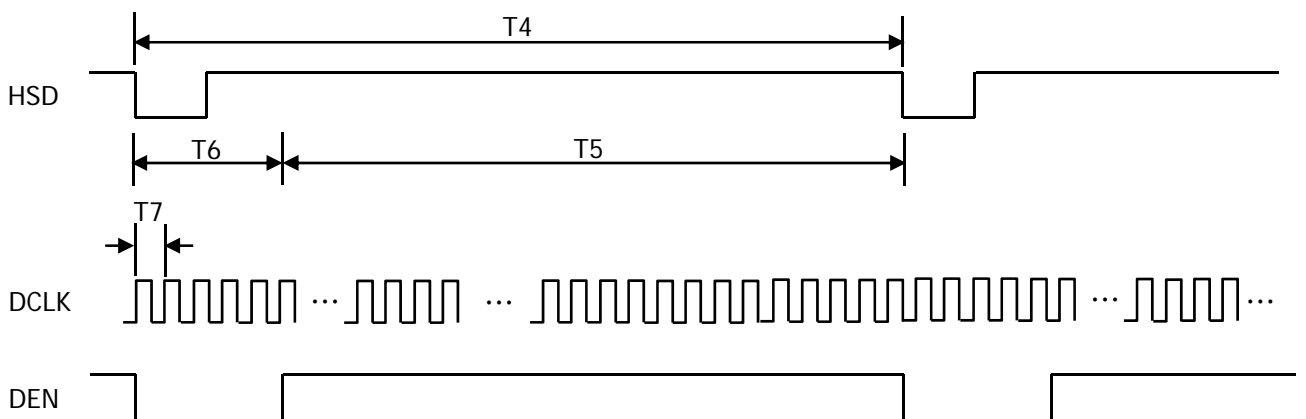



### 7.3 LVDS Rx Interface Timing Parameter

The specification of the LVDS Rx interface timing parameter

< Table 9, LVDS Rx Interface Timing Specification >

Item	Symbol	Min.	Typ.	Max.	Unit	Remarks
CLKIN Period	tRCIP	-	19.53	-	nsec	
Input Data 0	tRIP0	-0.4	0.0	+0.4	nsec	
Input Data 1	tRIP1	tRCIP/7-0.4	tRCIP/7	tRCIP/7+0.4	nsec	
Input Data 2	tRIP2	2 × tRCIP/7-0.4	2 × tRCIP/7	2 × tRCIP/7+0.4	nsec	
Input Data 3	tRIP3	3 × tRCIP/7-0.4	3 × tRCIP/7	3 × tRCIP/7+0.4	nsec	
Input Data 4	tRIP4	4 × tRCIP/7-0.4	4 × tRCIP/7	4 × tRCIP/7+0.4	nsec	
Input Data 5	tRIP5	5 × tRCIP/7-0.4	5 × tRCIP/7	5 × tRCIP/7+0.4	nsec	
Input Data 6	tRIP6	6 × tRCIP/7-0.4	6 × tRCIP/7	6 × tRCIP/7+0.4	nsec	

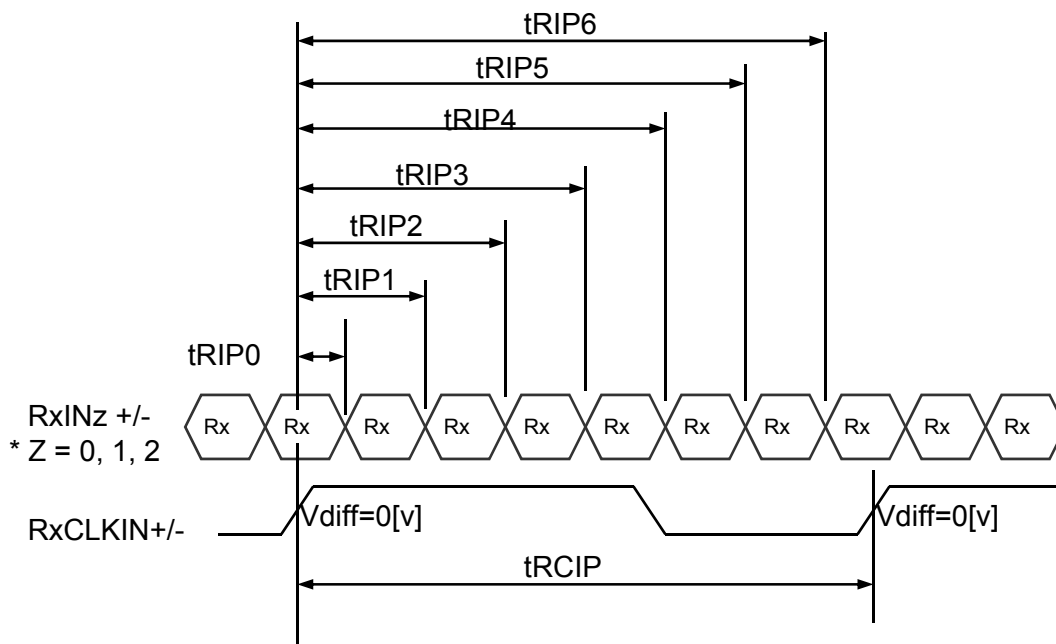



PRODUCT GROUP

REV

ISSUE DATE

TFT LCD PRODUCT

0

2012.06.25

## 8.0 INPUT SIGNALS, BASIC DISPLAY COLORS & GRAY SCALE OF COLORS

A total of 16.7M colors are displayed with dither & HFRC using 64 gray from 8bit input.

Colors & Gray Scale		Data signal																											
		Red data								Green data								Blue data											
		R0	R1	R2	R3	R4	R5	R6	R7	G0	G1	G2	G3	G4	G5	G6	G7	B0	B1	B2	B3	B4	B5	B6	B7				
Basic Colors	Black	0	0	0	0	0	0	0	0	0	0	0	0	0	0	0	0	0	0	0	0	0	0	0	0	0	0	0	0
	Blue	0	0	0	0	0	0	0	0	0	0	0	0	0	0	0	0	1	1	1	1	1	1	1	1	1	1	1	
	Green	0	0	0	0	0	0	0	0	1	1	1	1	1	1	1	1	0	0	0	0	0	0	0	0	0	0	0	
	Light Blue	0	0	0	0	0	0	0	0	1	1	1	1	1	1	1	1	1	1	1	1	1	1	1	1	1	1	1	
	Red	1	1	1	1	1	1	1	1	0	0	0	0	0	0	0	0	0	0	0	0	0	0	0	0	0	0	0	
	Purple	1	1	1	1	1	1	1	1	0	0	0	0	0	0	0	0	1	1	1	1	1	1	1	1	1	1	1	
	Yellow	1	1	1	1	1	1	1	1	1	1	1	1	1	1	1	1	0	0	0	0	0	0	0	0	0	0	0	
	White	1	1	1	1	1	1	1	1	1	1	1	1	1	1	1	1	1	1	1	1	1	1	1	1	1	1	1	
Gray Scale of Red	Black	0	0	0	0	0	0	0	0	0	0	0	0	0	0	0	0	0	0	0	0	0	0	0	0	0	0	0	
	△	1	0	0	0	0	0	0	0	0	0	0	0	0	0	0	0	0	0	0	0	0	0	0	0	0	0	0	
	Darker	0	1	0	0	0	0	0	0	0	0	0	0	0	0	0	0	0	0	0	0	0	0	0	0	0	0	0	
	△	↓								↓								↓											
	▽	↓								↓								↓											
	Brighter	1	0	1	1	1	1	1	1	0	0	0	0	0	0	0	0	0	0	0	0	0	0	0	0	0	0	0	
	▽	↓								0								0											
	Red	1	1	1	1	1	1	1	1	0	0	0	0	0	0	0	0	0	0	0	0	0	0	0	0	0	0	0	
Gray Scale of Green	Black	0	0	0	0	0	0	0	0	0	0	0	0	0	0	0	0	0	0	0	0	0	0	0	0	0	0	0	
	△	0	0	0	0	0	0	0	0	1	0	0	0	0	0	0	0	0	0	0	0	0	0	0	0	0	0	0	
	Darker	0	0	0	0	0	0	0	0	0	1	0	0	0	0	0	0	0	0	0	0	0	0	0	0	0	0	0	
	△	↓								↓								↓											
	▽	↓								↓								↓											
	Brighter	0	0	0	0	0	0	0	0	1	0	1	1	1	1	1	1	0	0	0	0	0	0	0	0	0	0	0	
	▽	0								0								0											
	Green	0	0	0	0	0	0	0	0	1	1	1	1	1	1	1	1	0	0	0	0	0	0	0	0	0	0	0	
Gray Scale of Blue	Black	0	0	0	0	0	0	0	0	0	0	0	0	0	0	0	0	0	0	0	0	0	0	0	0	0	0	0	
	△	0	0	0	0	0	0	0	0	0	0	0	0	0	0	0	0	1	0	0	0	0	0	0	0	0	0	0	
	Darker	0	0	0	0	0	0	0	0	0	0	0	0	0	0	0	0	0	1	0	0	0	0	0	0	0	0	0	
	△	↓								↓								↓											
	▽	↓								↓								↓											
	Brighter	0	0	0	0	0	0	0	0	0	0	0	0	0	0	0	0	1	0	1	1	1	1	1	1	1	1	1	
	▽	0								0								0											
	Blue	0	0	0	0	0	0	0	0	0	0	0	0	0	0	0	0	1	1	1	1	1	1	1	1	1	1	1	
Gray Scale of White & Black	Black	0	0	0	0	0	0	0	0	0	0	0	0	0	0	0	0	0	0	0	0	0	0	0	0	0	0	0	
	△	1	0	0	0	0	0	0	0	1	0	0	0	0	0	0	0	1	0	0	0	0	0	0	0	0	0	0	
	Darker	0	1	0	0	0	0	0	0	0	1	0	0	0	0	0	0	0	1	0	0	0	0	0	0	0	0	0	
	△	↓								↓								↓											
	▽	↓								↓								↓											
	Brighter	1	0	1	1	1	1	1	1	1	0	1	1	1	1	1	1	1	0	1	1	1	1	1	1	1	1	1	
	▽	↓								↓								↓											
	White	1	1	1	1	1	1	1	1	1	1	1	1	1	1	1	1	1	1	1	1	1	1	1	1	1	1	1	

SPEC. NUMBER  
S864-1470

SPEC TITLE  
HV070WS1-105 Product Specification

PAGE  
18 OF 34

## 9.0 3-WIRE SERIAL PORT INTERFACE (SPI INTERFACE)

This module use 3-wire serial port interface as function configuration and parameter setting

### 9.1 3-Wire command format

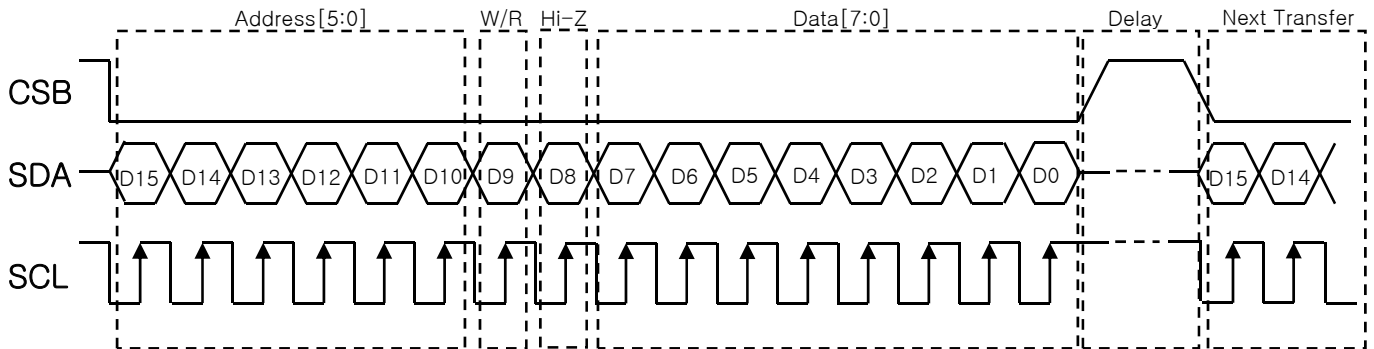

Bit	Description
D15-D10	Register Address [5:0]
D9	W/R control bit. "0" for Write; "1" for Read
D9	Hi-z bit during read mode. Any data within this bits will be ignored during write Mode
D7-D0	Data for the W/R operation to the address indicated by Address phase

### 9.2 3-Wire Write format

MSB															LSB	
D15	D14	D13	D12	D11	D10	D9	D8	D7	D6	D5	D4	D3	D2	D1	D1	
Register Address [5:0]						0	X	Data (Issued by external controller)								

### 9.3 3-Wire Read format

MSB															LSB	
D15	D14	D13	D12	D11	D10	D9	D8	D7	D6	D5	D4	D3	D2	D1	D1	
Register Address [5:0]						1	Hi-Z	Data (Issued by 3-wire engine)								

## 9.4 3-wire control register

### 9.4.1 R00 : System Control Register

Designation	Address	Description
MODE	R0[0]	DE/SYNC mode select. MODE = "0", HSD/VSD mode. MODE = "1", DE mode. (Default)
DCKPOL	R0[1]	DCLK polarity control bit DCKPOL = "0" : Data sampling at DCLK falling edge. (Default) DCKPOL = "1" : Data sampling at DCLK rising edge.
GRB	R0[2]	Global reset bit. GRB="0", The controller is in reset state. GRB="1", Normal operation. (Default)
STBYB	R0[3]	Standby mode selection bit. STBYB = "0", Timing control, driver and DC-DC converter, are off, and all outputs are High-Z. STBYB = "1", Normal operation. (Default)
UPDN	R0[4]	Gate Up or Down scan control. UPDN = "0", STV2 output vertical start pulse and UD pin output Logical "0" to Gate driver. (Default) UPDN = "1", STV1 output vertical start pulse and UD pin output Logical "1" to Gate driver. (Default)
SHLR	R0[5]	Right/Left sequence control of source driver. SHLR = "0", Shift left : Last data = S1<-S2<-S3...<-S960 = First Data SHLR = "1", Shift left : Last data = S1->S2->S3...->S960 = Last Data (Default)
-	R0[6]	Reserved
PWR_EN	R0[7]	POWER enable. PWR_EN = H, enable PWM, Charge pump and VCOM buffer.







## 9.4.2 R01 : System Control Register

Designation	Address	Description
	R1[0]	Reserved
RES[1:0]	R1[2:1]	Display resolution selection. RES[1:0] = "01", for 1024(RGB)*768 display resolution. (dual or cascade) RES[1:0] = "00", for 1024(RGB)*600 display resolution. (dual or cascade) (Default) RES[1:0] = "10", for 800(RGB)*600 display resolution. (dual or cascade) RES[1:0] = "11", for 800(RGB)*480 display resolution. (dual or cascade) (601~936 channel disable)
BIST	R1[3]	Normal Operation / BIST pattern select. BIST = H : BIST (DCLK input is not needed) BIST = L : Normal Operation (Default)
DITHER	R1[4]	Dithering function enable control. DITHER = "1", Enable internal dithering function. DITHER = "0", Disable internal dithering function. (Default)
HFRC	R1[5]	H-FRC selection HFRC = H : H-FRC enable HFRC = L : H-FRC disable (Default) If DITHER = H and HFRC = L : enable only FRC/dithering function If DITHER = L, disable dithering function (H-FRC and FRC both disable)
CABC_EN[1:0]	R1[7:6]	CABC H/W enable pin. Normally pull low. When CABC_EN = "00", CABC OFF. (Default mode) When CABC_EN = "01", User interface Image. When CABC_EN = "10", Still Picture. When CABC_EN = "11", Moving Image.

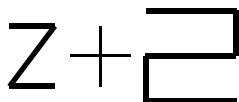
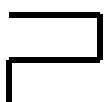
## 9.4.3 R02 : System Control Register

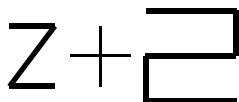
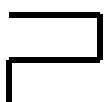
Designation	Address	Description
	R2[5:0]	Reserved
NBW	R2[6]	Normally black or normally white setting. NBW = H : Normally black NBW = L : Normally white (Default)
BIST	R2[7]	Reserved

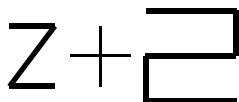
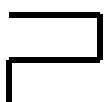
## 9.4.4 R03 : Gate on sequence controller register

Designation	Address	Description															
SEL[1:0]	R3[1:0]	Gate on sequence select															
		<table border="1"> <thead> <tr> <th>SEL[0]</th> <th>SEL[1]</th> <th>Pin control function</th> </tr> </thead> <tbody> <tr> <td>1</td> <td>1</td> <td></td> </tr> <tr> <td>1</td> <td>0</td> <td></td> </tr> <tr> <td>0</td> <td>1</td> <td></td> </tr> <tr> <td>0</td> <td>0</td> <td>Z (Default)</td> </tr> </tbody> </table>	SEL[0]	SEL[1]	Pin control function	1	1		1	0		0	1		0	0	Z (Default)
		SEL[0]	SEL[1]	Pin control function													
		1	1														
		1	0														
0	1																
0	0	Z (Default)															
Frame	R3[2]	Frame inverse or not select. FRAME = "1", Uniform FRAME = "0", Frame inverse (Default)															
-	R3[7:3]	Reserved															

## 9.4.5 R0E : test mode (1)

Designation	Address	Description
TEST_mode(1)	R0E[7:0]	Enter test mode (1) TEST_mode = 8'h5F, enter TEST_mode = other exit (Default)

## 9.4.6 R0F : test mode (2)

Designation	Address	Description
TEST_mode(2)	R0F[7:0]	Enter test mode (2) TEST_mode = 8'hA4, enter TEST_mode = other exit (Default)



## 9.4.7 R0D : charging time control (3)

Designation	Address	Description
OE_WIDTH	R0D[7:0]	Inversion type select. Enter Test mode (1) and (2) first. Then R0D setting will be active TEST_mode = 8'h00, increase charge time

## 9.4.8 R02 : charge sharing control

Designation	Address	Description
EQC_ADJ	R02[7:0]	Inversion type select. Enter Test mode (1) and (2) first. Then R10 setting will be active EQC_ADJ = 8'h43, adjust charge sharing time

## 9.4.9 R0A : BIAS current control (5)

Designation	Address	Description
BIAS_TRIG	R0A[7:0]	Inversion type select. Enter Test mode (1) and (2) first. Then R10 setting will be active BIAS_TRIG = 8'h28, trigger bias reduction

## 9.4.10 R10 : inversion architecture

Designation	Address	Description
INV	R10F[7:0]	Inversion type select. Enter Test mode (1) and (2) first. Then R10 setting will be active 2line / 1dot = 8'h41 1line / 1dot = 8'h01 (Default)

## 9.4.11 R38 : PWM\_DIV setting

Designation	Address	Description																											
PWM_DIV[3:0]	R38[7:0]	PWM Dimmer frequency step setting																											
		<table border="1"> <thead> <tr> <th>R38[7:0]</th> <th>PWM_DIV[3:0]</th> <th>Register function</th> </tr> </thead> <tbody> <tr> <td>0x0C</td> <td>000</td> <td>Don't use.</td> </tr> <tr> <td>0x1C</td> <td>001</td> <td>1</td> </tr> <tr> <td>0x2C</td> <td>010</td> <td>2</td> </tr> <tr> <td>0x3C</td> <td>011</td> <td>3</td> </tr> <tr> <td>0x4C</td> <td>100</td> <td>4</td> </tr> <tr> <td>0x5C</td> <td>101</td> <td>5</td> </tr> <tr> <td>0x6C</td> <td>110</td> <td>6</td> </tr> <tr> <td>0x7C</td> <td>111</td> <td>7 (Default)</td> </tr> </tbody> </table>	R38[7:0]	PWM_DIV[3:0]	Register function	0x0C	000	Don't use.	0x1C	001	1	0x2C	010	2	0x3C	011	3	0x4C	100	4	0x5C	101	5	0x6C	110	6	0x7C	111	7 (Default)
		R38[7:0]	PWM_DIV[3:0]	Register function																									
		0x0C	000	Don't use.																									
		0x1C	001	1																									
		0x2C	010	2																									
		0x3C	011	3																									
		0x4C	100	4																									
		0x5C	101	5																									
		0x6C	110	6																									
0x7C	111	7 (Default)																											
<table border="1"> <thead> <tr> <th>PWM Reference Frequency (FOSC)</th> <th>Real PWM Frequency of DIMO</th> </tr> </thead> <tbody> <tr> <td>51.2MHz (Typical)</td> <td> <math display="block">\text{PWM Frequency} = \frac{\text{FOSC}}{256 \times 128 \times \text{PWM\_DIV}[2:0]}</math> </td> </tr> </tbody> </table>	PWM Reference Frequency (FOSC)	Real PWM Frequency of DIMO	51.2MHz (Typical)	$\text{PWM Frequency} = \frac{\text{FOSC}}{256 \times 128 \times \text{PWM\_DIV}[2:0]}$																									
PWM Reference Frequency (FOSC)	Real PWM Frequency of DIMO																												
51.2MHz (Typical)	$\text{PWM Frequency} = \frac{\text{FOSC}}{256 \times 128 \times \text{PWM\_DIV}[2:0]}$																												
In order to maintain the dimming frequency for brightness control at different display resolution (typical 1024 x 600) at normal mode. We will change default value of PWM_DIV to follow as table																													
<table border="1"> <thead> <tr> <th>Display Resolution</th> <th>Default value of PWM_DIV</th> </tr> </thead> <tbody> <tr> <td>RES[1:0] = "00"</td> <td>111</td> </tr> <tr> <td>RES[1:0] = "01"</td> <td>111</td> </tr> <tr> <td>RES[1:0] = "10"</td> <td>110</td> </tr> <tr> <td>RES[1:0] = "11"</td> <td>100</td> </tr> </tbody> </table>	Display Resolution	Default value of PWM_DIV	RES[1:0] = "00"	111	RES[1:0] = "01"	111	RES[1:0] = "10"	110	RES[1:0] = "11"	100																			
Display Resolution	Default value of PWM_DIV																												
RES[1:0] = "00"	111																												
RES[1:0] = "01"	111																												
RES[1:0] = "10"	110																												
RES[1:0] = "11"	100																												

Note : The R6 and R38 register will be available when the R0E and R0F register already had issued.





# HYDIS

PRODUCT GROUP

REV

ISSUE DATE

TFT LCD PRODUCT

0

2012.06.25

### 9.5 Recommend Register Setting (CABC Off mode)

Register write sequence : R00 (Reset)→ R00 (Into Standby mode) → R01 (Enable FRC / Dither, CABC off) → R02 (Enable Normally Black) → R0E (Enter Test mode (1)) → R0F (Enter Test mode (2))→ R0D (SDRRS on) → R00 (Release standby mode)

If you don't use register write sequence, it may cause faulty operation.

	D15	D14	D13	D12	D11	D10	D9	D8	D7	D6	D5	D4	D3	D2	D1	D0	Setting	Remark
R00	0	0	0	0	0	0	0	0	0	0	1	0	1	0	0	1	0x0029	
R00	0	0	0	0	0	0	0	0	0	0	1	0	0	1	0	1	0x0025	
R01	0	0	0	0	0	1	0	0	0	0	1	1	0	0	0	0	0x0430	
R02	0	0	0	0	1	0	0	0	0	1	0	0	0	0	0	0	0x0840	
R0E	0	0	1	1	1	0	0	0	0	1	0	1	1	1	1	1	0x385F	
R0F	0	0	1	1	1	1	0	0	1	0	1	0	0	1	0	0	0x3CA4	
R10	0	1	0	0	0	0	0	0	0	1	0	0	0	0	0	1	0X4041	2dot inv.
R0D	0	0	1	1	0	1	0	0	0	0	0	0	0	0	0	1	0x3401	
R00	0	0	0	0	0	0	0	0	0	0	1	0	1	1	0	1	0x002D	

### 9.6 Recommend Register Setting (CABC on mode (Moving Picture))

Register write sequence : R00 (Reset)→ R00 (Into Standby mode) → R01 (Enable FRC / Dither, CABC on) → R02 (Enable Normally Black) → R0E (Enter Test mode (1)) → R0F (Enter Test mode (2)) → R0D (SDRRS on)→ R38 (PWM Frequency = 1.5KHz) → R00 (Release standby mode)

If you don't use register write sequence, it may cause faulty operation.

	D15	D14	D13	D12	D11	D10	D9	D8	D7	D6	D5	D4	D3	D2	D1	D0	Setting	Remark
R00	0	0	0	0	0	0	0	0	0	0	1	0	1	0	0	1	0x0029	
R00	0	0	0	0	0	0	0	0	0	0	1	0	0	1	0	1	0x0025	
R01	0	0	0	0	0	1	0	0	0	0	1	1	0	0	0	0	0x04F0	
R02	0	0	0	0	1	0	0	0	0	1	0	0	0	0	0	0	0x0840	
R0E	0	0	1	1	1	0	0	0	0	1	0	1	1	1	1	1	0x385F	
R0F	0	0	1	1	1	1	0	0	1	0	1	0	0	1	0	0	0x3CA4	
R10	0	1	0	0	0	0	0	0	0	1	0	0	0	0	0	1	0X4041	2dot inv.
R0D	0	0	1	1	0	1	0	0	0	0	0	0	0	0	0	1	0x3401	
R38	1	1	1	0	0	0	0	0	0	0	0	1	1	1	0	0	0xE01C	
R00	0	0	0	0	0	0	0	0	0	0	1	0	1	1	0	1	0x002D	

SPEC. NUMBER  
S864-1470

SPEC TITLE  
HV070WS1-105 Product Specification

PAGE  
25 OF 34

## 10.0 POWER SEQUENCE

To prevent a latch-up or DC operation of the LCD module, the power on/off sequence shall be as shown in below

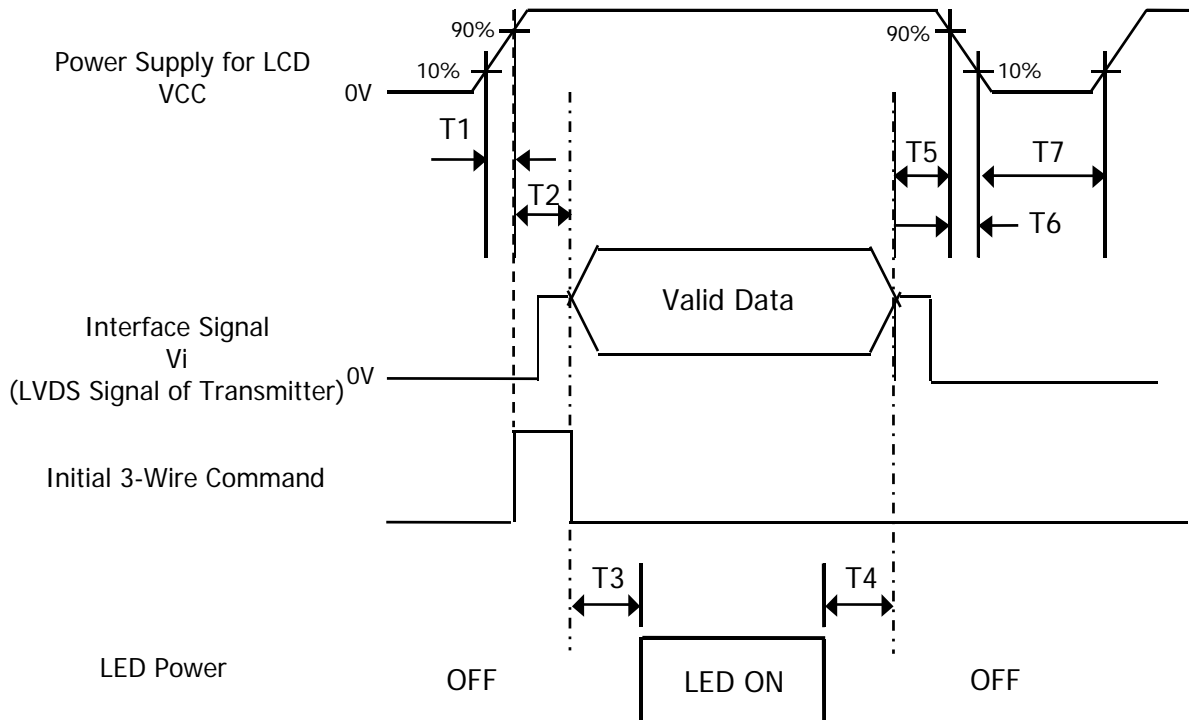

Parameter	Value			Unit	Remark
	Min.	Typ.	Max.		
T1	0.5		10	ms	
T2	0		16	ms	
T3	200			ms	
T4	200			ms	
T5	0			ms	
T6	3			ms	
T7	400			ms	

- Notes :
1. When the power supply VDD is 0V, Keep the level of input signals on the low or keep high impedance.
  2. Do not keep the interface signal high impedance when power is on.
  3. Back Light must be turn on after power for logic and interface signal are valid.



## 11.0 MECHANICAL CHARACTERISTICS

### 11.1 Dimensional Requirements

Figure 5 & 6 (located in 12.0) shows mechanical outlines for the model

<Table9, Mechanical Characters >

Parameter	Specification	Unit
Active Area	153.60(H) X 90.00(V)	mm
Number of pixels	1024(H) X 600(V) (1 pixel = R + G + B dots)	
Pixel pitch	0.15(H) X 0.15(V)	
Pixel arrangement	RGB Vertical stripe	
Display colors	16.7M	
Display mode	Normally Black	
Outline dimension	163.6±0.3(H) × 102.9±0.3(V) × 2.47±0.2(D)	mm
Weight	95 (Max.)	g
Back-light	Edge side 20-LEDs type ( 5 X 4 Array)	

### 11.2 Polarizer Hardness.

The surface of the LCD has an coating to reduce scratching.

### 11.3 Light Leakage

There shall not be visible light from the back-lighting system around the edges of the screen as seen from a distance 50cm from the screen with an overhead light level of 150lux. The manufacture shall furnish limit samples of the panel showing the light leakage acceptable.

## 12.0 MECHANICAL DRAWING

**Figure 5. TFT-LCD Module Outline Dimension (Front View)**

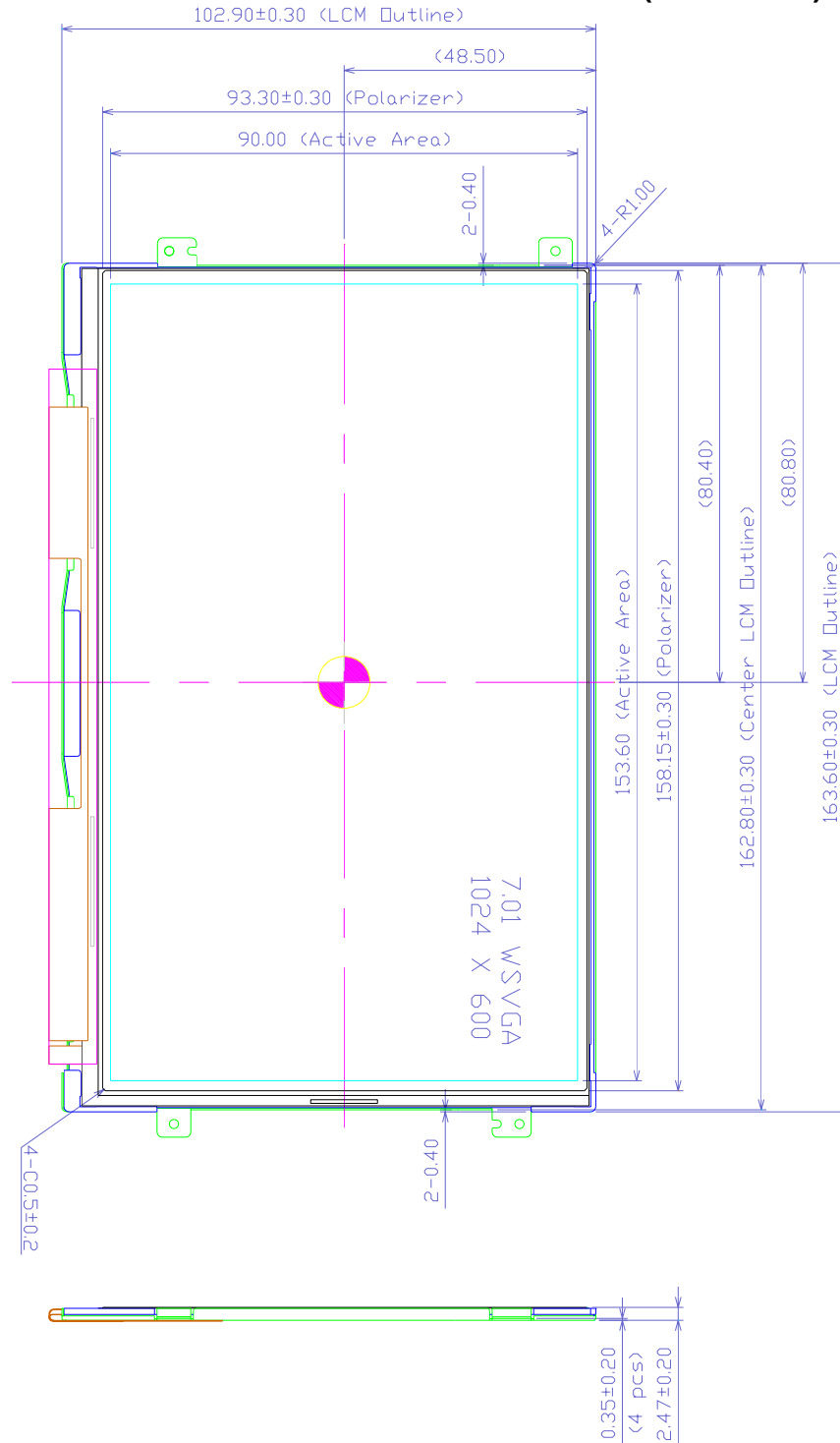

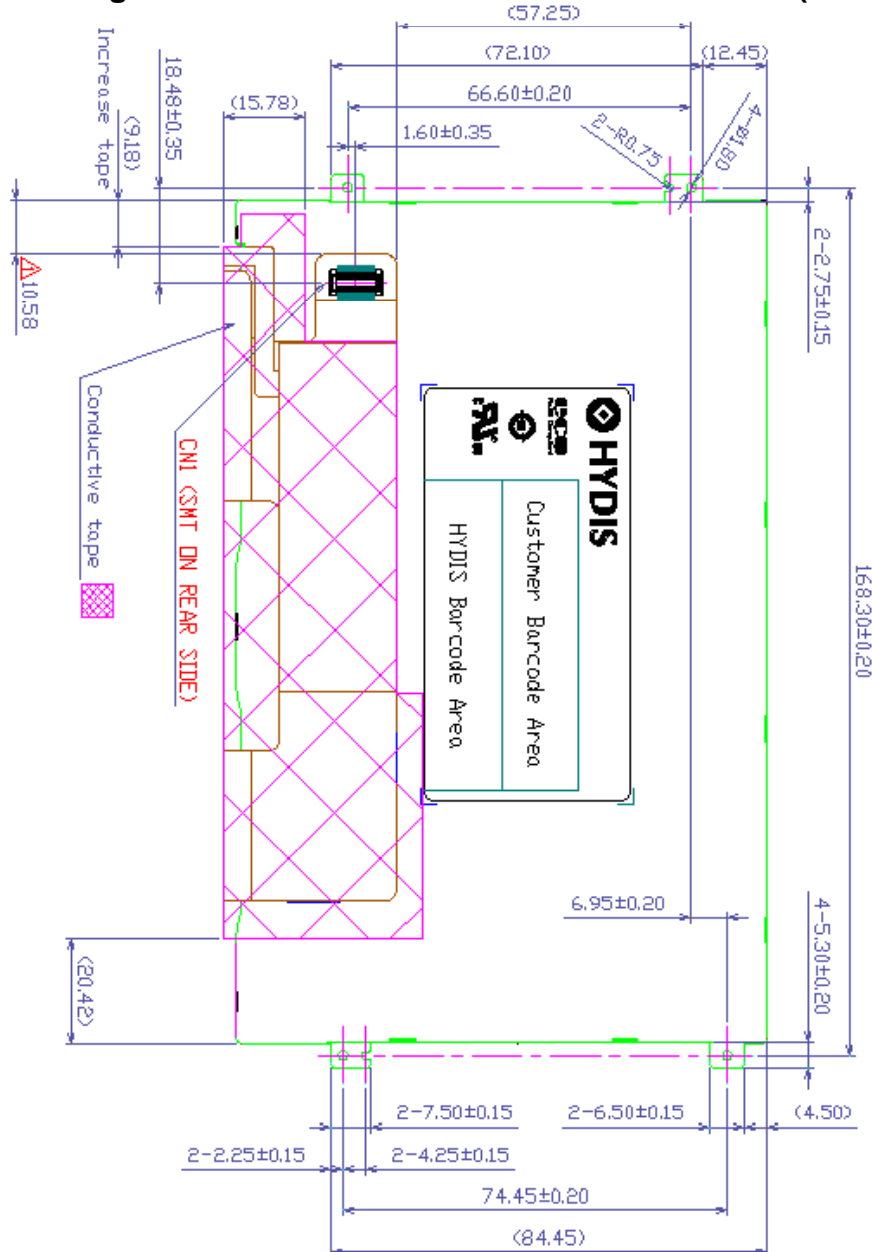
**Figure 6. TFT-LCD Module Outline Dimensions (Rear view)**

**NOTE**

1. CNI: HIROSE DF23C-30DS-0.5V
2. BL FPC SOLDERING HIGHT : 0.5 Max. (Form PCB)
3. LCM BENDING ALLOWANCE SPEC. : 0.3
4. LCM BURR SPEC : INNER SIDE 0.03 Max.
5. OTHER SPECIFICATION : REFERS TO SPEC SHEET



PRODUCT GROUP

REV

ISSUE DATE

TFT LCD PRODUCT

O

2012.06.25

### 13.0 RELIABILITY TEST

The Reliability test items and its conditions are shown in below.

<Table10, Reliability Test>

No	Test Item	Conditions
1	Temperature and Humidity test (Operation)	1. Ta = 40°C/90% 24hr 2. Ta = 40°C/30% 24hr 3. Ta = 0°C 24hr
2	Temperature and Humidity Cycling (Storage)	Ta = 85°C/90%RH (2H) , -20°C (2H), Waypoint(25°C 25% RH turn off Humidity control) 12cycle. 144Hr
3	Thermal shock	Ta = -40 °C ↔ 85 °C (30min residence), 100 cycle
4	Low temperature storage test	Ta = -40 °C, 300 hrs
5	Low Temperature Test (Operation)	Ta = -20 °C, 300hrs
6	Biased Humidity/Heat Soak Test (Storage)	Ta = 85 °C /85%, 300hr
7	Altitude storage	20000 ft/-40 °C, 24hr
8	Hot Start Test	Ta = 85 °C 1hr, power on/off per 5m, 5 time
9	Cold Start Test	Ta = -40 °C 1hr, power on/off per 5m, 5 time
10	Mechanical shock	100 G, 6 ms, half sine wave(±X, ±Y, ±Z). Acceleration measured shock table.
11	Mechanical Random vibration	3.5 Grms, PSD =0.025g <sup>2</sup> /Hz, 5-500 Hz 15 minutes in all axes (X, Y, Z)
12	4 Pt Bend Test	1. 7 kgf deflection. Scribed edge side up 2. 4 kgf deflection. Scribed edge side down
13	Ring on Ring Test	X kgf applied. Load rae:75mm/min
14	ESD	Screen: 150 pF, 330 Ohm, +/-15kV air, +/- 8 kV contact. FPC: 100 pFm100 Ohm, +/-200V 10 points, 20times/pt
15	Functional Test	Page flip script, 2 m flips

Notes :

1. Except form over the conditions of the polarizer specifications.
2. ESD test condition is standard of customer system.

SPEC. NUMBER  
S864-1470

SPEC TITLE  
HV070WS1-105 Product Specification

PAGE  
30 OF 34



**HYDIS**

PRODUCT GROUP	REV	ISSUE DATE
TFT LCD PRODUCT	O	2012.06.25

**14.0 HANDLING & CAUTIONS**

**14.1 Cautions when taking out the module**

- Pick the pouch only, when taking out module from a shipping package.

**14.2 Cautions for handling the module**

- As the electrostatic discharges may break the LCD module, handle the LCD module with care. Peel a protection sheet off from the LCD panel surface as slowly as possible.
- As the LCD panel and back - light element are made from fragile glass (epoxy) material, impulse and pressure to the LCD module should be avoided.
- As the surface of the polarizer is very soft and easily scratched, use a soft dry cloth without chemicals for cleaning.
- Do not pull the interface connector in or out while the LCD module is operating.
- Put the module display side down on a flat horizontal plane.
- Handle connectors and cables with care.

**14.3 Cautions for the operation**

- When the module is operating, do not lose MCLK, DE signals. If any one of these signals were lost, the LCD panel would be damaged.
- Obey the supply voltage sequence. If wrong sequence is applied, the module would be damaged.

**14.4 Cautions for the atmosphere**

- Dew drop atmosphere should be avoided.
- Do not store and/or operate the LCD module in a high temperature and/or humidity atmosphere. Storage in an electro-conductive polymer packing pouch and under relatively low temperature atmosphere is recommended.

**14.5 Cautions for the module characteristics**

- Do not apply fixed pattern data signal to the LCD module at product aging.
- Applying fixed pattern for a long time may cause image sticking.

**14.6 Cautions for the digitizer assembly**

- When assembling FPC connector, do not flip connector past 90° due to possible damage to connector.
- When positioning digitizer underneath driver IC, do not lift driver IC past 90° due to possible damage to drive IC pattern.
- Please be warned that during assembly of digitizer, the opening or closing of FPC will result in possible electrostatic discharge damage to the LED

**14.7 Other cautions**

- Do not re-adjust variable resistor or switch etc.
- When returning the module for repair or etc., Please pack the module not to be broken. We recommend to use the original shipping packages.

SPEC. NUMBER S864-1470	SPEC TITLE HV070WS1-105 Product Specification	PAGE 31 OF 34
---------------------------	--	------------------



**HYDIS**

PRODUCT GROUP

REV

ISSUE DATE

TFT LCD PRODUCT

O

2012.06.25

### 15.0 LABELS

#### 15.1 Product Label

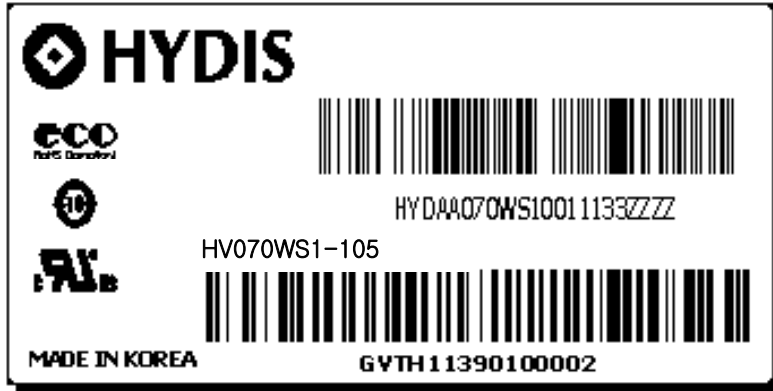

#### Customer Barcode

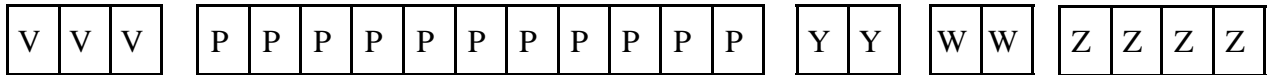

01~03 : Vendor code

17~18 : Manufactured week

04~14 : QPN

19~22 : Serial number (32 digit/alphabet)

15~16 : Manufactured year

#### HYDIS Barcode

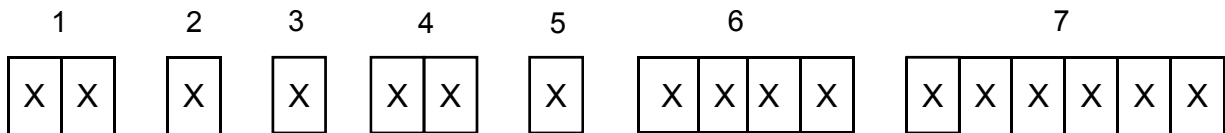

No 1. Control Number

No 5. Month (1, 2, 3, ..., 9, X, Y, Z)

No 2. Rank / Grade

No 6. FG Code

No 3. Line Classification  
(Hydis: H, TOC: T, IDS: C)

No 7. Serial Number

No 4. Year (5 : 2005, 6 : 2006, ...)

SPEC. NUMBER  
S864-1470

SPEC TITLE  
HV070WS1-105 Product Specification

PAGE  
32 OF 34





**HYDIS**

PRODUCT GROUP

REV

ISSUE DATE

TFT LCD PRODUCT

0

2012.06.25

**15.2 Packing Label**

Label Size: 108 mm (L) × 56 mm (W)

Contents

Model: HV070WS1-105

Q`ty: Module Q`ty in one box

Serial No.: Box Serial No. See next figure for detail description.

Date: Packing Date

FG Code: FG Code of Product

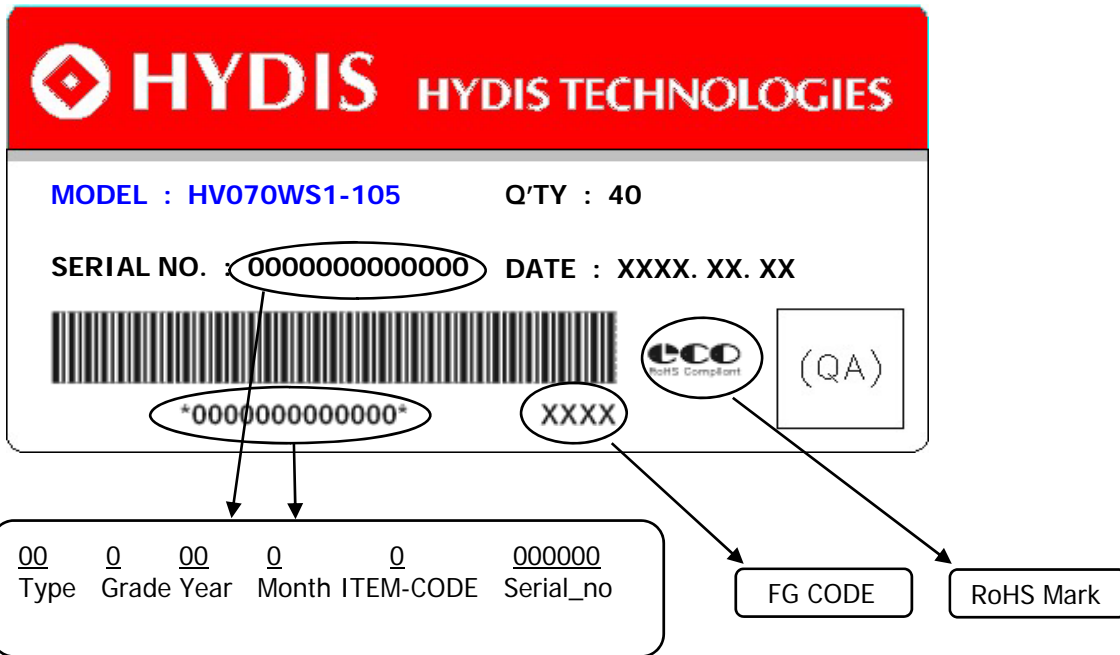

SPEC. NUMBER  
S864-1470

SPEC TITLE  
HV070WS1-105 Product Specification

PAGE  
33 OF 34

## 16.0 PACKING INFORMATION

### 16.1 Packing order

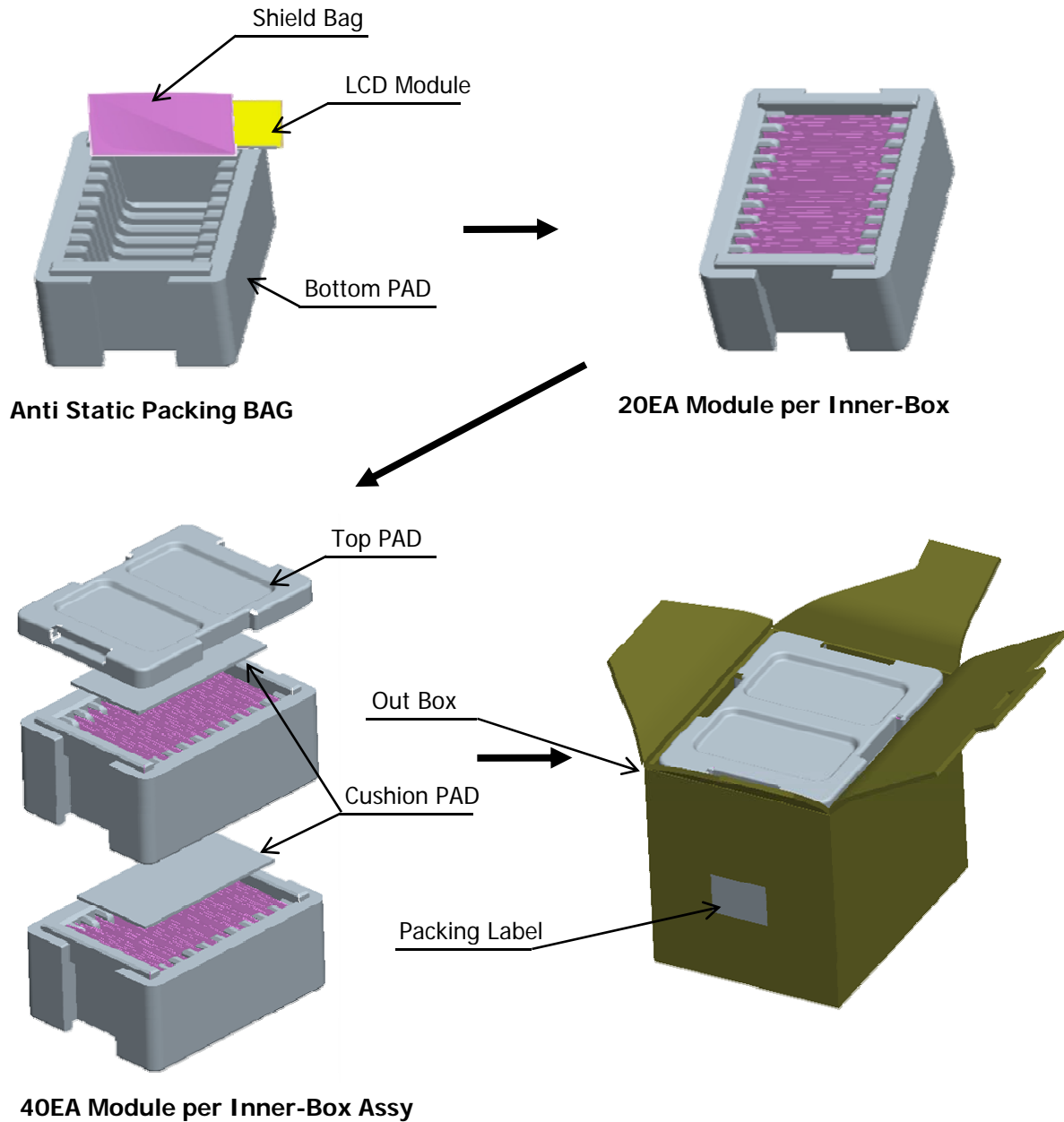

- Notes : 1. Box Dimension: 350mm(W) X 265mm(D) X 320mm(H)  
 2. Package Quantity in one Box : 40pcs