



PROPRIETARY NOTE

THIS SPECIFICATION IS THE PROPERTY OF BOE TFT-LCD SBU AND SHALL NOT BE REPRODUCED OR COPIED WITHOUT THE WRITTEN PERMISSION OF BOE TFT-LCD SBU AND MUST BE RETURNED TO BOE TFT-LCD SBU UPON ITS REQUEST.

TITLE :

HT14X1B-121
Product Specification

REV. O

BOE TFT-LCD SBU
BEIJING BOE OPTOELECTRONICS TECHNOLOGY
BOE HYDIS TECHNOLOGY

SPEC. NUMBER	PRODUCT GROUP	REV.	ISSUE DATE	PAGE
S864-1243	TFT-LCD PRODUCT	O	2005. 10. 04	1 OF 24



PRODUCT GROUP

REV.

ISSUE DATE

TFT-LCD PRODUCT

O

2005. 10. 04

REVISION HISTORY

REV.	ECN NO.	DESCRIPTION OF CHANGES	DATE	PREPARED
O	-	Initial Release	05.10.04	B.C.Kim
SPEC. NUMBER S864-1243		SPEC. TITLE HT14X1B-121 Product Specification		PAGE 2 OF 24



PRODUCT GROUP

REV.

ISSUE DATE

TFT-LCD PRODUCT

O

2005. 10. 04

Contents

	Page
1.0 General Description	4
2.0 Absolute Maximum Ratings.....	5
3.0 Electrical Specifications.....	6
4.0 Optical Specifications.....	7
5.0 Interface Connection	9
6.0 Signal Timing Specification	12
7.0 Signal Timing Waveforms	13
8.0 Input Signals, Display Colors & Gray Scale of Colors	15
9.0 Power Sequence	16
10.0 Mechanical Characteristics	17
11.0 Reliability Test	18
12.0 Handling & Cautions.....	18
13.0 Packing Information	19
14.0 Product Label	19
15.0 Appendix	20

1.0 GENERAL DESCRIPTION

1.1 Introduction

HT14X1B-121 is a color active matrix TFT LCD module using amorphous silicon TFT's (Thin Film Transistors) as an active switching devices. This module has a 14.1 inch diagonally measured active area with XGA resolutions (1024 horizontal by 768 vertical pixel array). Each pixel is divided into RED, GREEN, BLUE dots which are arranged in vertical Stripe and this module can display 262,144 colors. The TFT-LCD panel used for this module is a low reflection and higher color type. Therefore, this module is suitable for Notebook PC. The

SPEC. NUMBER S864-1243	SPEC. TITLE HT14X1B-121 Product Specification	PAGE 3 OF 24
---------------------------	--	-----------------

DC/AC inverter for back-light driving is not built in this model.

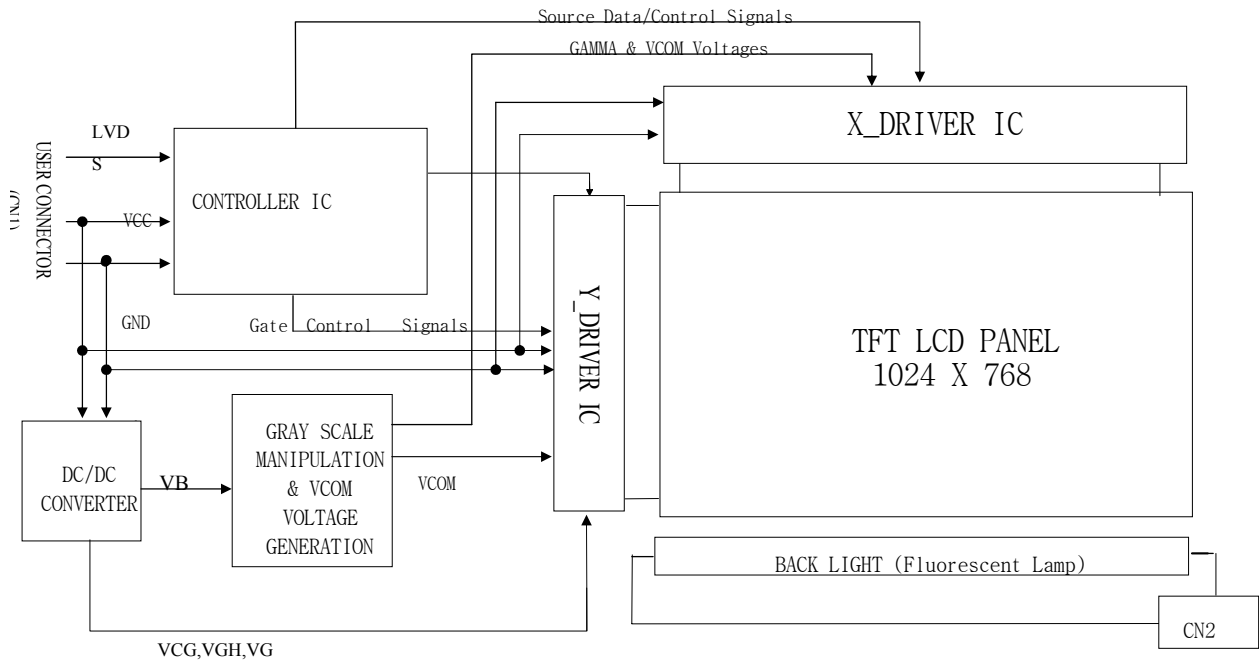

1.2 Features

- “SPWG Style B (Except Thickness)” Form Factor
- Thin and light weight
- 3.3 V power supply
- 1 Channel LVDS Interface
- Single CCFL (Bottom side/Horizontal Direction)
- 262,144 colors
- Data enable signal mode
- Side Mounting Frame
- Green Product (RoHS)

1.3 General Specification

The followings are general specifications at the model HT14X1B-121. (listed in Table 1.)

<Table 1. General Specifications>

Parameter	Specification	Unit	Remarks
Active area	285.696 (H) × 214.272(V)	mm	
Number of pixels	1024(H) × 768(V)	pixels	
Pixel pitch	0.279(H) × 0.279(V)	mm	



PRODUCT GROUP

REV.

ISSUE DATE

TFT-LCD PRODUCT

O

2005. 10. 04

Pixel arrangement	RGB Vertical stripe		
Display colors	262,144	colors	
Display mode	Normally white		
Dimensional outline	299.0±0.3(W) × 228.0±0.3(V) × 5.2(D)typ/5.5(D)max	mm	
Weight	400 g (typ.)	g	
Back-light	CCFL, Horizontal-lamp type		Note 1

Note 1: CCFL (Cold Cathode Fluorescent Lamp)

2.0 ABSOLUTE MAXIMUM RATINGS

The followings are maximum values which, if exceed, may cause faulty operation or damage to the unit. The operational and non-operational maximum voltage and current values are listed in Table 2.

< Table 2. Absolute Maximum Ratings >

Parameter	Symbol	Min.	Max.	Unit	Remarks
Power Supply Voltage	V _{DD}	-0.3	4.0	V	
Logic Supply Voltage	V _{IN}	-0.3	V _{DD} +0.3	V	
Operating Temperature	T _{OP}	0	+50	°C	
Storage Temperature	T _{SP}	-20	+70	°C	

3.0 ELECTRICAL SPECIFICATIONS

3.1 Electrical Specifications

< Table 3. Electrical specifications >

Parameter		Min.	Typ.	Max.	Unit	Remarks
Power Supply Voltage	V _D D	3.0	3.3	3.6	V	Note1
Permissible Input Ripple Voltage	V _{RF}			100	mV	At V _{DD} = 3.3V
Power Supply Current	I _{DD}		385		mA	Note1
High Level Differential Input Signal Voltage	V _{IH}		-	+100	mV	

SPEC. NUMBER
S864-1243

SPEC. TITLE
HT14X1B-121 Product Specification

PAGE
5 OF 24



PRODUCT GROUP

REV.

ISSUE DATE

TFT-LCD PRODUCT

O

2005. 10. 04

Low Level Differential Input Signal Voltage	V _{IL}	-100	-		mV	
Back-light Lamp Voltage	V _{BL}		625		V _{rms}	Note2
Back-light Lamp Current	I _{BL}	2.0	6.0	7.0	mA	
Back-light Lamp operating Frequency	F _L	40	60	70	KHz	One Lamp , Note3
Lamp Start Voltage			(950)	1,200	V _{rms}	At Ta = 25 °C
			(1,040)	1,400	V _{rms}	At Ta = 0 °C
Lamp Life		10,000	15,000		Hrs	At I _{BL} = 6mA, Note4
Power Consumption	P _D		1.2		W	Typ. @ Black
	P _{BL}		3.8		W	Note5, I _{BL} =6mA
	P _{total}		5.0	6.0	W	

Notes : 1. The supply voltage is measured and specified at the interface connector of LCM.

The current draw and power consumption specified is for 3.3V at 25 °C.

a) Typ: Black Pattern

2. Reference value, which is measured with Samsung Electric SIC-180 Inverter.

(V_{BLMIN} is value at I_{BLMIN} and V_{BLMAX} is value at I_{BLMAX})

3. The lamp frequency should be selected as different as possible from the horizontal synchronous frequency and its harmonics to avoid interference which may cause line flow on the display

4. End of Life shall be determined by the time when any of the following is satisfied under continuous lighting at 25 °C and I_{BL} = 6.0[mA].

- Intensity drops to 50% of the Initial Value.

- Driving(Start-up) Voltage during minimum temperature operation is 1300 V_{rms}.

5. Calculated value for reference (VBL × IBL)

4.0 OPTICAL SPECIFICATION

4.1 Overview

The test of Optical specifications shall be measured in a dark room (ambient luminance ≤ 1 lux and temperature = 25±2 °C) with the equipment of Luminance meter system (Goniometer system and TOPCONE BM-5) and test unit shall be located at an approximate distance 50cm from the LCD surface at a viewing angle of Θ and Φ equal to 0°. We refer to $\Theta_{\theta=0}$ (= Θ_3) as the 3 o'clock direction (the “right”), $\Theta_{\theta=90}$ (= Θ_{12}) as the 12 o'clock direction (“upward”), $\Theta_{\theta=180}$ (= Θ_9) as the 9 o'clock direction (“left”) and

$\Theta_{\theta=270}$ (= Θ_6) as the 6 o'clock direction (“bottom”). While scanning Θ and/or Φ , the center of the measuring spot on the Display surface shall stay fixed. The backlight should be operating for 30

SPEC. NUMBER
S864-1243

SPEC. TITLE
HT14X1B-121 Product Specification

PAGE
6 OF 24

minutes prior to measurement... VDD shall be 3.3+/- 0.3V at 25°C. Optimum viewing angle direction is 6 o'clock.

4.2 Optical Specifications

<Table 4. Optical Specifications>

Parameter		Symbol	Condition	Min.	Typ.	Max.	Unit	Remark
Viewing Angle range	Horizontal	Θ_3	CR > 10	40	45		Deg.	Note 1
		Θ_9		40	45		Deg.	
	Vertical	Θ_{12}		10	15		Deg.	
		Θ_6		25	35		Deg.	
Luminance Contrast ratio		CR	$\Theta = 0^\circ$	150	200			Note 2
Center Luminance of White	1 Point	Y_w	$\Theta = 0^\circ$ IBL = 6mA	175	200		cd/m ²	Note 3
	5 Points			165	185			
White Luminance uniformity	5 Points	ΔY_5		0.85				Note 4
	13 Points	ΔY_{13}		0.65				
White Chromaticity		x_w	$\Theta = 0^\circ$	0.273	0.303	0.333		Note 5
		y_w		0.295	0.325	0.355		
Reproduction of color	Red	x_R	$\Theta = 0^\circ$	0.554	0.584	0.614		
		y_R		0.308	0.338	0.368		
	Green	x_G		0.262	0.292	0.322		
		y_G		0.532	0.562	0.592		
	Blue	x_B		0.116	0.146	0.176		
		y_B		0.095	0.125	0.155		
Response Time	Rise	T_r	Ta= 25° C		20	40	ms	Note 6
	Decay	T_d	$\Theta = 0^\circ$		30	50	ms	
Cross Talk		CT	$\Theta = 0^\circ$			2.0	%	Note 7

Note:

- Viewing angle is the angle at which the contrast ratio is greater than 10. The viewing angles are determined for the horizontal or 3, 9 o'clock direction and the vertical or 6, 12 o'clock direction with respect to the optical axis which is normal to the LCD surface (see FIGURE1 shown in Appendix).
- Contrast measurements shall be made at viewing angle of $\Theta = 0^\circ$ and at the center of the LCD surface. Luminance shall be measured with all pixels in the view field set first to white, then to the dark (black) state. (see FIGURE1 shown in Appendix) Luminance Contrast Ratio (CR) is defined mathematically as CR = Luminance when displaying a white raster / Luminance when displaying a black raster.
- Center Luminance of white is defined as luminance values of center 1 point and 5 points across the LCD surface. Luminance shall be measured with all pixels in the view field set first to white. This measurement shall be taken at the locations shown in FIGURE 2 for a total of

the measurements per display.

4. The White luminance uniformity on LCD surface is then expressed as : $\Delta Y_5 = \text{Minimum Luminance of five points} / \text{Maximum Luminance of five points}$ (see FIGURE 2) , $\Delta Y_{13} = \text{Minimum Luminance of 13 points} / \text{Maximum Luminance of 13 points}$ (see FIGURE 3).
5. The color chromaticity coordinates specified in Table 4. shall be calculated from the spectral data measured with all pixels first in red, green, blue, and white. Measurements shall be made at the center of the panel.
6. The electro-optical response time measurements shall be made as shown in FIGURE 4 (shown in Appendix) by switching the “data” input signal ON and OFF. The times needed for the luminance to change from 10% to 90% is Td and 90% to 10% is Tr.
7. Cross-Talk of one area of the LCD surface by another shall be measured by comparing the luminance (Y_A) of a 25mm diameter area, with all display pixels set to a gray level, to the luminance (Y_B) of that same area when any adjacent area is driven dark (Refer to FIGURE 5).

5.0 INTERFACE CONNECTION.

5.1 Electrical Interface Connection

The electronics interface connector is a model FI-XB30S-HF10 manufactured by JAE or equivalent. The mating connector part number is FI-X30H or FI-X30M or equivalent. The connector interface pin assignments are listed in Table 5.

<Table 5. Pin Assignments for the Interface Connector>

Pin No	Symbol	Function	Remark
1	GND	GROUND	
2	VDD	Power Supply : +3.3V	
3	VDD	Power Supply : +3.3V	
4	Reserved	Reserved (for V_{EDID})	
5	Reserved-	Reserved (for Supplier test point)	
6	Reserved	Reserved (for Ck_{EDID})	
7	Reserved	Reserved (for $DATA_{EDID}$)	
8	RxINO-	Transmission Data of 0 Negative	[R0 ~ R5,GO]
9	RxINO+	Transmission Data of 0 Positive +	[R0 ~ R5,GO]
10	GND	GROUND	
11	RxIN1-	Transmission Data of 1 Negative	[G1 ~ G5,BO ~ B1]
12	RxIN1+	Transmission Data of 1 Positive +	[G1 ~ G5,BO ~ B1]
13	GND	GROUND	
14	RxIN2-	Transmission Data of 2 Negative	[B2 ~ B5,HS,VS,DE]
15	RxIN2+	Transmission Data of 2 Positive +	[B2 ~ B5,HS,VS,DE]
16	GND	GROUND	
17	RxCLKIN-	Sampling Clock of Negative -	[CLOCK INPUT]
18	RxCLKIN+	Sampling Clock of Positive +	[CLOCK INPUT]

19	GND	GROUND	
20	NC	NO CONECTION	
21	NC	NO CONECTION	
22	GND	GROUND	
23	NC	NO CONECTION	
24	NC	NO CONECTION	
25	GND	GROUND	
26	NC	NO CONECTION	
27	NC	NO CONECTION	
28	GND	GROUND	
29	NC	NO CONECTION	
30	NC	NO CONECTION	

5-2. LVDS Interface

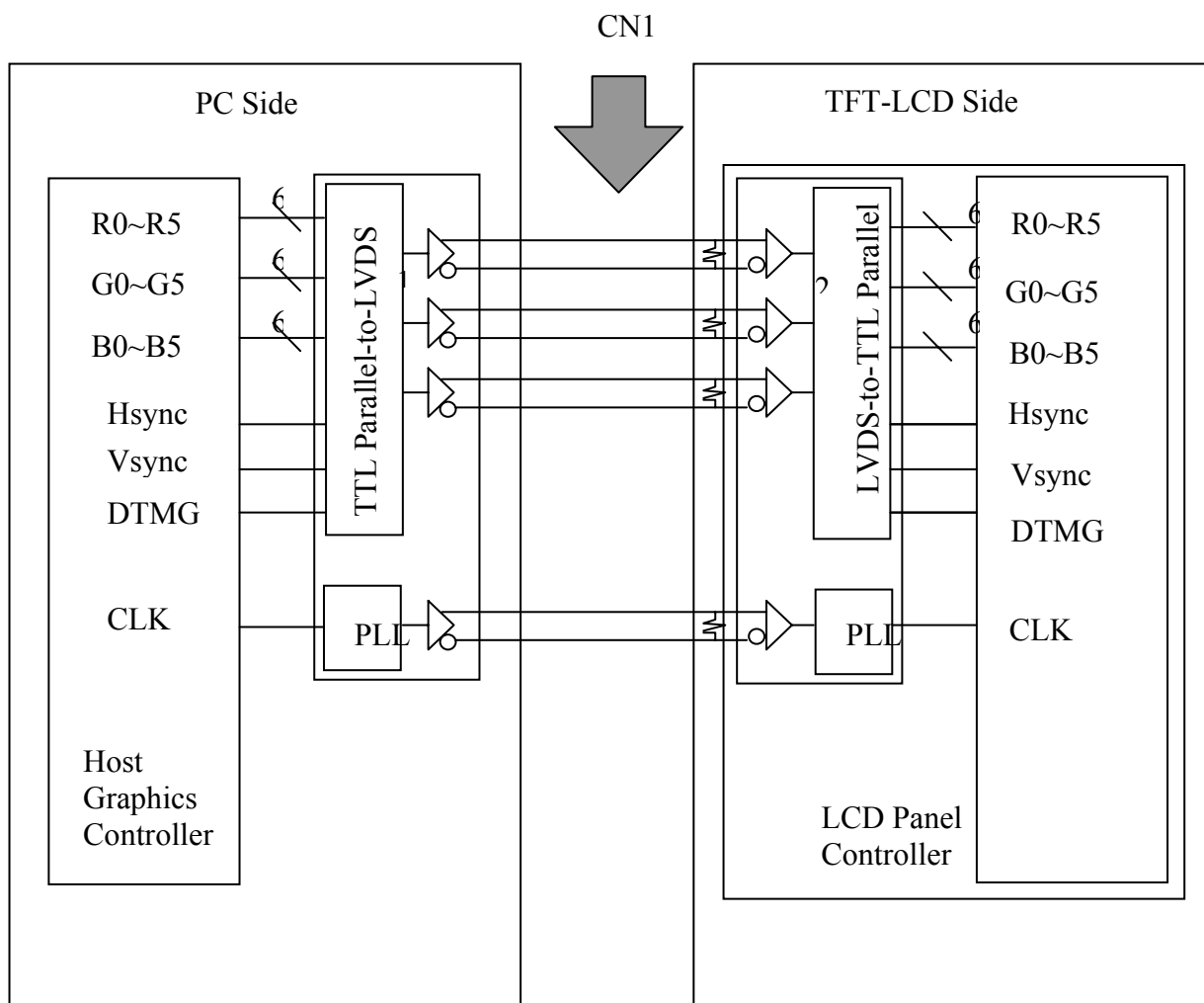

- NOTE : 1) LVDS cable impedance is 100 ohms per signal line when two are used differentially...
- 2) Transmitter : Thine THC63LVDM63A, or equivalent. Transmitter is not contained in Module.

5-3.LVDS Input signal

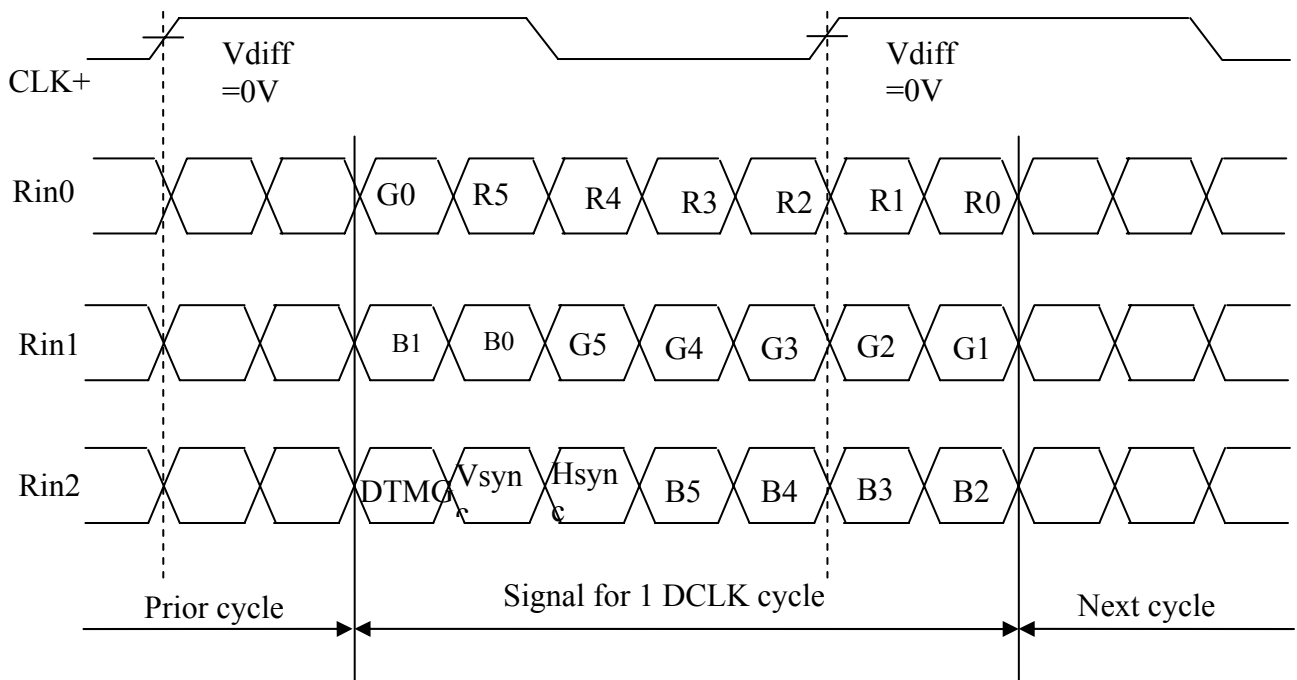

Pin connection in case of using
Thine THC63LVDM63A

Input signal	Transmitter	Input signal	Transmitter
DCLK	CLK IN(26)	G4	TB3(10)
R0	TA0(44)	G5	TB4(12)



PRODUCT GROUP

REV.

ISSUE DATE

TFT-LCD PRODUCT

O

2005. 10. 04

R1	TA1(45)	B0	TB5(13)
R2	TA2(47)	B1	TB6(15)
R3	TA3(48)	B2	TC0(16)
R4	TA4(1)	B3	TC1(18)
R5	TA5(3)	B4	TC2(19)
G0	TA6(4)	B5	TC3(20)
G1	TB0(6)	Hsync	TC4(22)
G2	TB1(7)	Vsync	TC5(23)
G3	TB2(9)	DTMG	TC6(25)

5.5.Back-light Interface

The Back-light interface connector is a model BHSR-02VS-1 manufactured by JST or equivalent. The connector interface pin assignments are listed in Table 7.

<Table 7. Back-light Electrical Interface>

Terminal No.	Symbol	Function	Color
1	VL	CCFL Power Supply(High Voltage)	Pink
2	GL	CCFL Power Supply(GND Side)	Black

6.0 SIGNAL TIMING SPECIFICATION

The specification of the signal timing parameters are listed in Table 8.

<Table 8. Signal Timing Specification.>

SPEC. NUMBER
S864-1243

SPEC. TITLE
HT14X1B-121 Product Specification

PAGE
11 OF 24

ITEM	Symbol	Min.	Typ.	Max.	Unit	Remarks
Frame Period	t1	772 x t3	806 x t3 16.67	1536 x t3	-- ms	60Hz
Vertical Display Period	t2	768 x t3	768 x t3 15.88	768 x t3	ms	
One Line Scanning Period	t3	1088 x t5	1344 x t5 20.67	2048 x t5 -	-- us	48.38KHz
Horizontal Display Period	t4	1024 x t5	1024 x t5 15.75	1024 x t5	-- us	
Clock Time	t5		15.38		ns	65MHz
Clock "L" Time	t6	5.0			ns	
Clock "H" Time	t7	4.0			ns	
Set up Time	t8	3.5			ns	
Hold Time	t9	3.5			ns	

7.0 NAL TIMING WAVEFORMS

7.1 Vertical Timing Waveforms

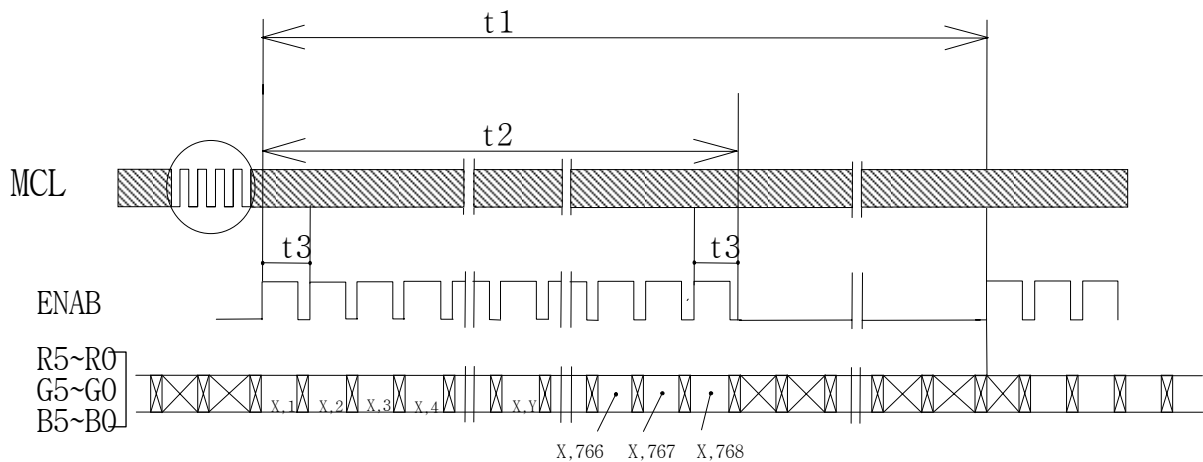

7.2 Horizontal Timing Waveforms

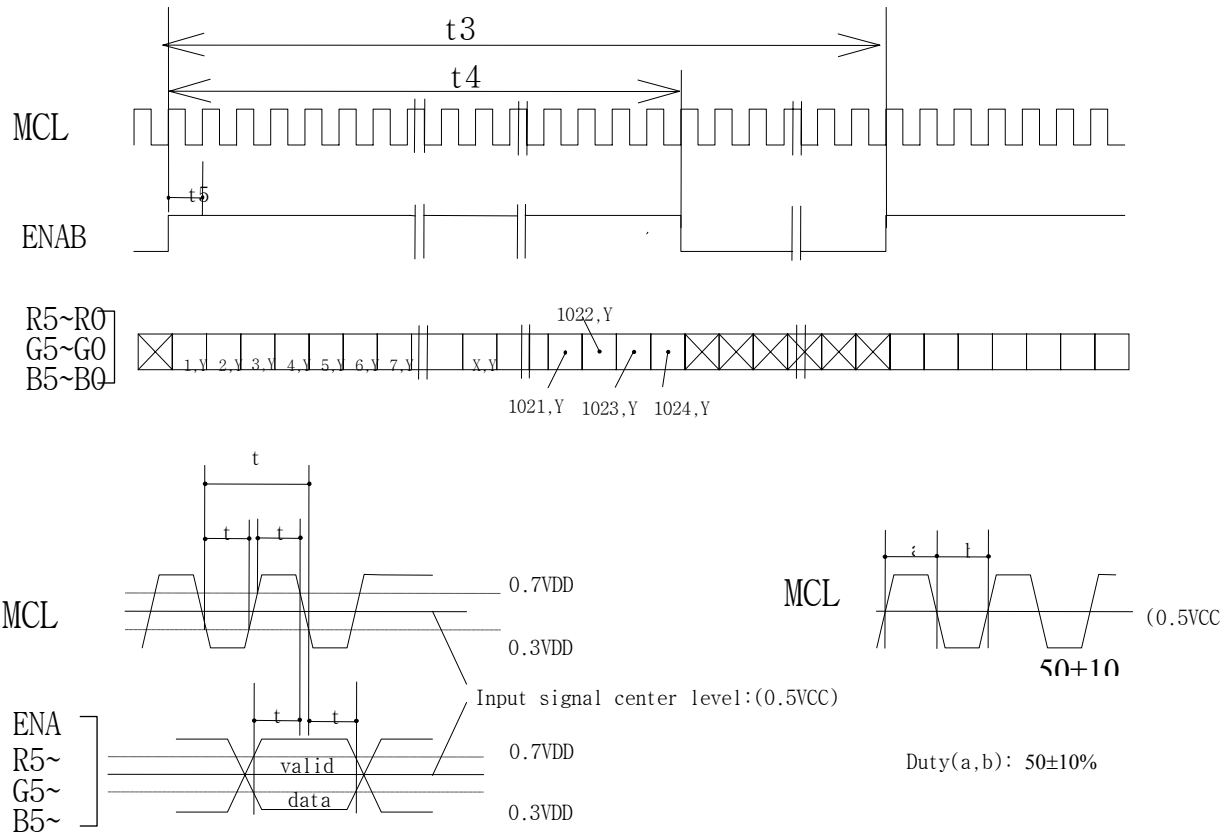

7.3 LVDS Rx Interface Timing Parameter

The specification of the LVDS Rx interface timing parameter is listed in Table 9.

<Table 9. LVDS Rx Interface Timing Specification>

Item	Symbol	Min	Typ	Max	Unit	Remark
PLL Set	tRPLL	-	-	10.0	msec	
CLKIN Period	tRCIP	11.76	15.38	50	nsec	
Input Data 0	tRIP1	-0.4	0.0	+0.4	nsec	
Input Data 1	tRIP0	$tRCIP/7-0.4$	$tRCIP/7$	$tRCIP/7+0.4$	nsec	
Input Data 2	tRIP6	$2 \times tRCIP/7-0.4$	$2 \times tRCIP/7$	$2 \times tRCIP/7+0.4$	nsec	
Input Data 3	tRIP5	$3 \times tRCIP/7-0.4$	$3 \times tRCIP/7$	$3 \times tRCIP/7+0.4$	nsec	
Input Data 4	tRIP4	$4 \times tRCIP/7-0.4$	$4 \times tRCIP/7$	$4 \times tRCIP/7+0.4$	nsec	
Input Data 5	tRIP3	$5 \times tRCIP/7-0.4$	$5 \times tRCIP/7$	$5 \times tRCIP/7+0.4$	nsec	
Input Data 6	tRIP2	$6 \times tRCIP/7-0.4$	$6 \times tRCIP/7$	$6 \times tRCIP/7+0.4$	nsec	

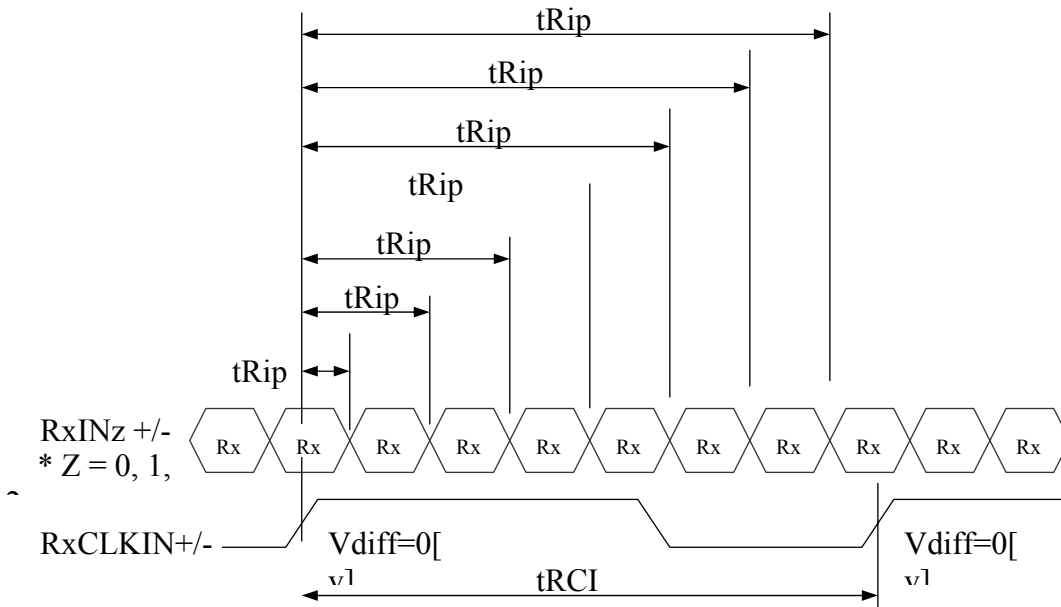

8.0 INPUT SIGNALS, BASIC DISPLAY COLORS & GRAY SCALE OF COLORS

Each color is displayed in sixty-four gray scales from a 6 bit data signal input. A total of 262,144 colors are derived from the resultant 18 bit data. Table 10. shows the input signals, basic display colors and gray scale for each color.

<Table 10. Input signals, Basic display colors and Gray scale for each color.>



PRODUCT GROUP

REV.

ISSUE DATE

TFT-LCD PRODUCT

O

2005. 10. 04

	Colors & Gray scale	Data signal																	
		R0	R1	R2	R3	R4	R5	G0	G1	G2	G3	G4	G5	B0	B1	B2	B3	B4	B5
Basic colors	Black	0	0	0	0	0	0	0	0	0	0	0	0	0	0	0	0	0	0
	Blue	0	0	0	0	0	0	0	0	0	0	0	0	1	1	1	1	1	1
	Green	0	0	0	0	0	0	1	1	1	1	1	1	0	0	0	0	0	0
	Light Blue	0	0	0	0	0	0	1	1	1	1	1	1	1	1	1	1	1	1
	Red	1	1	1	1	1	1	0	0	0	0	0	0	0	0	0	0	0	0
	Purple	1	1	1	1	1	1	0	0	0	0	0	0	1	1	1	1	1	1
	Yellow	1	1	1	1	1	1	1	1	1	1	1	1	0	0	0	0	0	0
	White	1	1	1	1	1	1	1	1	1	1	1	1	1	1	1	1	1	1
Gray scale of Red	Black	0	0	0	0	0	0	0	0	0	0	0	0	0	0	0	0	0	0
	=	1	0	0	0	0	0	0	0	0	0	0	0	0	0	0	0	0	0
	Darker	0	1	0	0	0	0	0	0	0	0	0	0	0	0	0	0	0	0
	=				△						△						△		
	∩				△						△						△		
	Brighter	1	0	1	1	1	1	0	0	0	0	0	0	0	0	0	0	0	0
	∩	0	1	1	1	1	1	0	0	0	0	0	0	0	0	0	0	0	0
	Red	1	1	1	1	1	1	0	0	0	0	0	0	0	0	0	0	0	0
Gray scale of Green	Black	0	0	0	0	0	0	0	0	0	0	0	0	0	0	0	0	0	0
	=	0	0	0	0	0	0	1	0	0	0	0	0	0	0	0	0	0	0
	Darker	0	0	0	0	0	0	0	1	0	0	0	0	0	0	0	0	0	0
	=				△						△						△		
	∩				△						△						△		
	Brighter	0	0	0	0	0	0	1	0	1	1	1	1	0	0	0	0	0	0
	∩	0	0	0	0	0	0	0	1	1	1	1	1	0	0	0	0	0	0
	Green	0	0	0	0	0	0	1	1	1	1	1	1	0	0	0	0	0	0
Gray scale of Blue	Black	0	0	0	0	0	0	0	0	0	0	0	0	0	0	0	0	0	0
	=	0	0	0	0	0	0	0	0	0	0	0	0	1	0	0	0	0	0
	Darker	0	0	0	0	0	0	0	0	0	0	0	0	0	1	0	0	0	0
	=				△						△						△		
	∩				△						△						△		
	Brighter	0	0	0	0	0	0	0	0	0	0	0	0	1	0	1	1	1	1
	∩	0	0	0	0	0	0	0	0	0	0	0	0	0	1	1	1	1	1
	Blue	0	0	0	0	0	0	0	0	0	0	0	0	1	1	1	1	1	1
Gray scale of White & Black	Black	0	0	0	0	0	0	0	0	0	0	0	0	0	0	0	0	0	0
	=	1	0	0	0	0	0	1	0	0	0	0	0	1	0	0	0	0	0
	Darker	0	1	0	0	0	0	0	1	0	0	0	0	0	1	0	0	0	0
	=				△						△						△		
	∩				△						△						△		
	Brighter	1	0	1	1	1	1	1	0	1	1	1	1	1	0	1	1	1	1
	∩	0	1	1	1	1	1	0	1	1	1	1	1	0	1	1	1	1	1
	White	1	1	1	1	1	1	1	1	1	1	1	1	1	1	1	1	1	1

SPEC. NUMBER
S864-1243

SPEC. TITLE
HT14X1B-121 Product Specification

PAGE
15 OF 24

9.0 POWER SEQUENCE

To prevent a latch-up or DC operation of the LCD module, the power on/off sequence shall be as shown in below

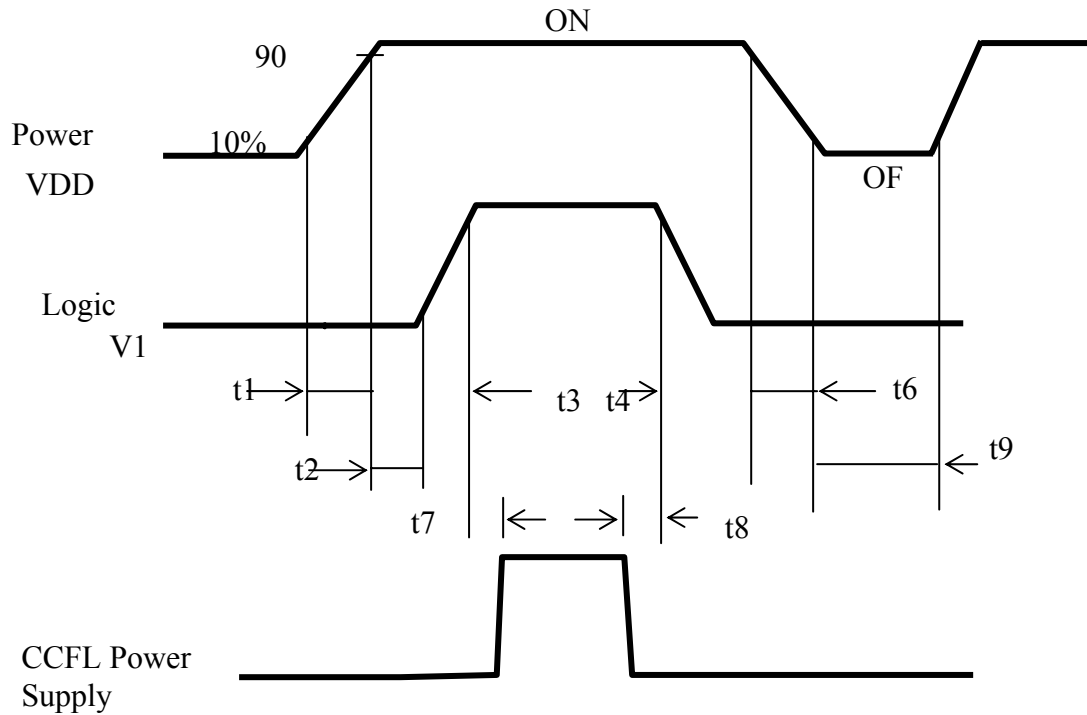

$$\begin{array}{ll}
 t1 \leq 10 \text{ ms} & 0 \leq t4 \leq 50 \text{ ms} \\
 0 \leq t2 \leq 50 \text{ ms} & 0 \leq t5 \leq 50 \text{ ms} \\
 0 \leq t3 \leq 50 \text{ ms} & t6 \leq 10 \text{ ms} \\
 t7 \geq 200 \text{ ms} & t8 \geq 0 \text{ ms} \\
 t9 \geq 100 \text{ ms} &
 \end{array}$$

* SET $0V \leq V1(t) \leq VDD(t)$

HERE, $V1(t)$, $VDD(t)$ indicate the transitive state of $V1$, VDD when the power supply is turned ON or OFF

Note1. : Do not keep the interface signal high-impedance when power is on.

10.0 MECHANICAL CHARACTERISTICS

SPEC. NUMBER
S864-1243

SPEC. TITLE
HT14X1B-121 Product Specification

PAGE
16 OF 24



PRODUCT GROUP

REV.

ISSUE DATE

TFT-LCD PRODUCT

O

2005. 10. 04

10.1 Dimensional Requirements

FIGURE 6 (located in Appendix) shows mechanical outlines for the model HT14X1B-121. Other parameters are shown in Table 11.

<Table 11. Dimensional Parameters.>

Parameter	Specification	Unit
Active area	285.696 (H) × 214.272(V)	mm
Number of pixels	1024(H) × 768(V)	pixels
	(1 pixel = R + G + B dots)	
Pixel pitch	0.279(H) × 0.279(V)	mm
Pixel arrangement	RGB Vertical stripe	
Display colors	262,144	colors
Display mode	Normally white	
Dimensional outline	299.0±0.3(W) × 228.0±0.3(V) × 5.2(D)typ./5.5(D)max	mm
Weight	400g (typ.)	gram
Back-light	CCFL, Horizontal-lamp type	

10.2 Mounting

See FIGURE 6. (shown in Appendix)

10.3 Anti-Glare and Polarizer Hardness.

The surface of the LCD has an anti-glare coating to minimize reflection and a coating to reduce scratching.

10.4 Light Leakage

There shall not be visible light from the back-lighting system around the edges of the screen as seen from a distance 50cm from the screen with an overhead light level of 350lux.

11.0 RELIABILITY TEST

SPEC. NUMBER
S864-1243

SPEC. TITLE
HT14X1B-121 Product Specification

PAGE
17 OF 24

The Reliability test items and its conditions are shown in below.

<Table 12. Reliability test>

No	Test Items	Conditions
1	High temperature storage test	Ta = 60 °C, 240 hrs
2	Low temperature storage test	Ta = -20 °C, 240 hrs
3	High temperature & high humidity operation test	Ta = 50 °C, 80~85%RH, 1000hrs
4	Life test	Ta = 25 °C, 1000 hrs
5	High temperature operation test	Ta = 60 °C, 240hrs
6	Low temperature operation test	Ta = 0 °C, 500hrs
7	Thermal shock	Ta = -20 °C ↔ 60 °C (0.5 hr), 100 cycle
8	Vibration test (non-operating)	1.5G, 10~200Hz for X,Y,Z axis 30 minutes for each axis
9	Shock test (non-operating)	50G, 18msec, trapezoidal 210G, 3msec, half sine
10	Altitude test	53.3 Kpa (altitude 5000m), 24 hrs
11	Open/Shot test	DS 518, Open/Shot Test plan
12	Electro-static discharge test (non-operating)	Air : 150 pF, 330 Ω, 15 KV Contact : 150 pF, 330 Ω, 8 KV

12.0 HANDLING & CAUTIONS

- (1) Cautions when taking out the module
 - Pick the pouch only, when taking out module from a shipping package.
- (2) Cautions for handling the module
 - As the electrostatic discharges may break the LCD module, handle the LCD module with care. Peel a protection sheet off from the LCD panel surface as slowly as possible.
 - As the LCD panel and back - light element are made from fragile glass material, impulse and pressure to the LCD module should be avoided.
 - As the surface of the polarizer is very soft and easily scratched, use a soft dry cloth without chemicals for cleaning.
 - Do not pull the interface connector in or out while the LCD module is operating.
 - Put the module display side down on a flat horizontal plane.
 - Handle connectors and cables with care.
- (3) Cautions for the operation
 - When the module is operating, do not lose CLK, ENAB signals. If any one of these signals is lost, the LCD panel would be damaged.
 - Obey the supply voltage sequence. If wrong sequence is applied, the module would be damaged.
- (4) Cautions for the atmosphere
 - Dew drop atmosphere should be avoided.
 - Do not store and/or operate the LCD module in a high temperature and/or



PRODUCT GROUP

REV.

ISSUE DATE

TFT-LCD PRODUCT

O

2005. 10. 04

humidity atmosphere. Storage in an electro-conductive polymer packing pouch and under relatively low temperature atmosphere is recommended.

(5) Cautions for the module characteristics

- Do not apply fixed pattern data signal to the LCD module at product aging.
- Applying fixed pattern for a long time may cause image sticking.

(6) Other cautions

- Do not disassemble and/or re-assemble LCD module.
- Do not re-adjust variable resistor or switch etc.
- When returning the module for repair or etc., Please pack the module not to be broken. We recommend to use the original shipping packages.

13.0 PACKING INFORMATION

BOE HYDIS provides the standard shipping container for customers, unless customer specifies their packing information.

14.0 PRODUCT LABEL

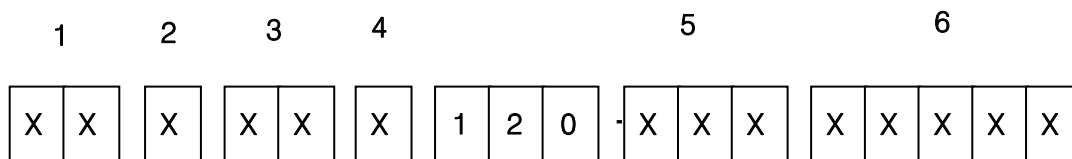

Type designation

No 1. Control Number

No 4. Month (1, 2, 3, ..., 9, X, Y, Z)

No 2. Rank / Grade

No 5. Product Identification

No 3. Year (03 : 2003, 04 : 2004, ...)

No 6. Serial Number

15.0 APPENDIX

Figure 1. Measurement Set Up

SPEC. NUMBER
S864-1243

SPEC. TITLE
HT14X1B-121 Product Specification

PAGE
19 OF 24

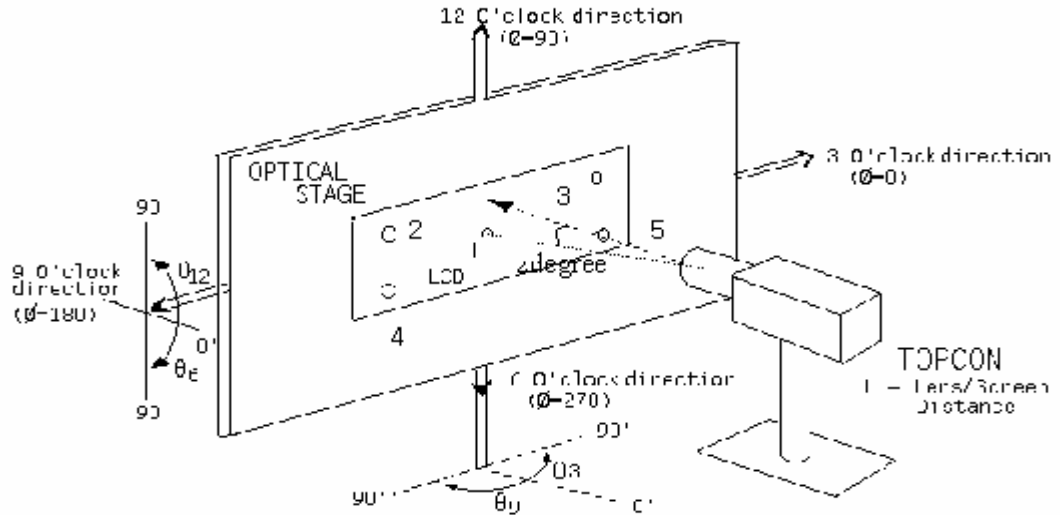
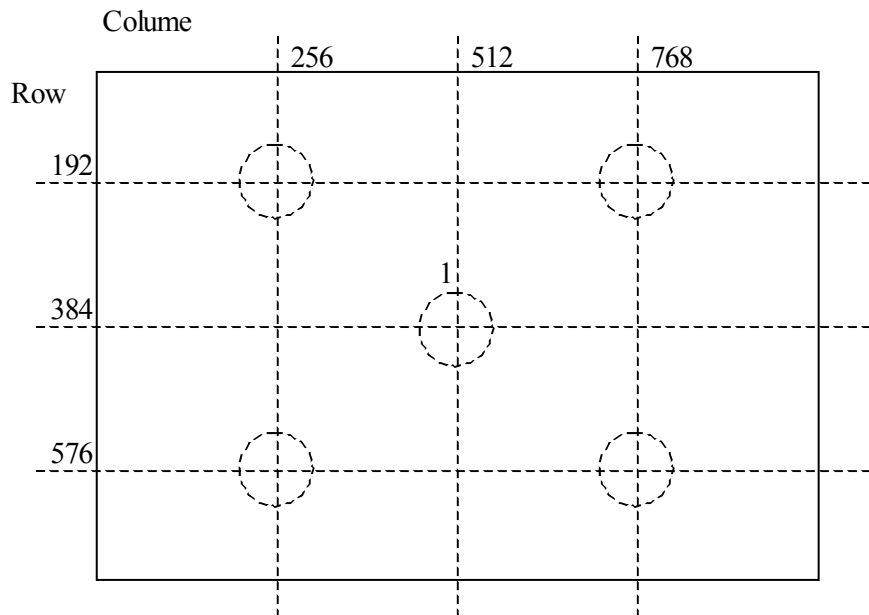
Figure 2. White Luminance and Uniformity Measurement Locations (5 points)

Figure 3. Uniformity Measurement Locations (13 points)

SPEC. NUMBER S864-1243	10mm	SPEC. TITLE 256: HT14XB-121 Product Specification	10mm	PAGE 20 OF 24
---------------------------	------	--	------	------------------

Figure 4. Response Time Testing

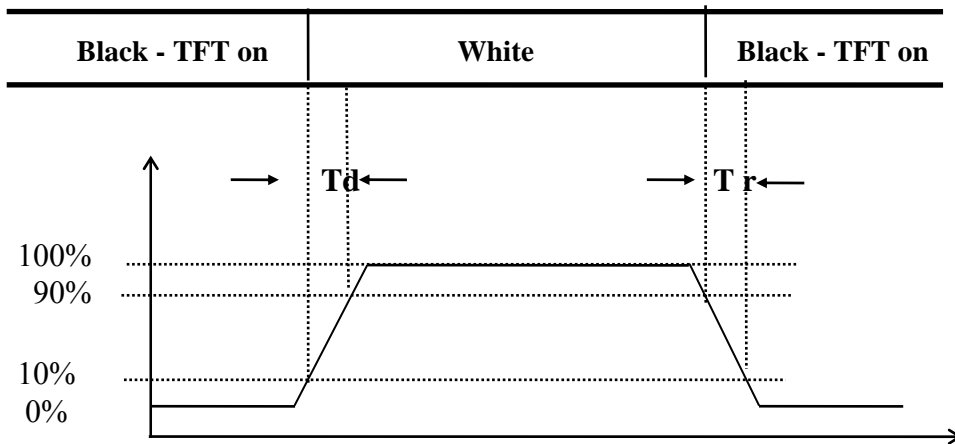
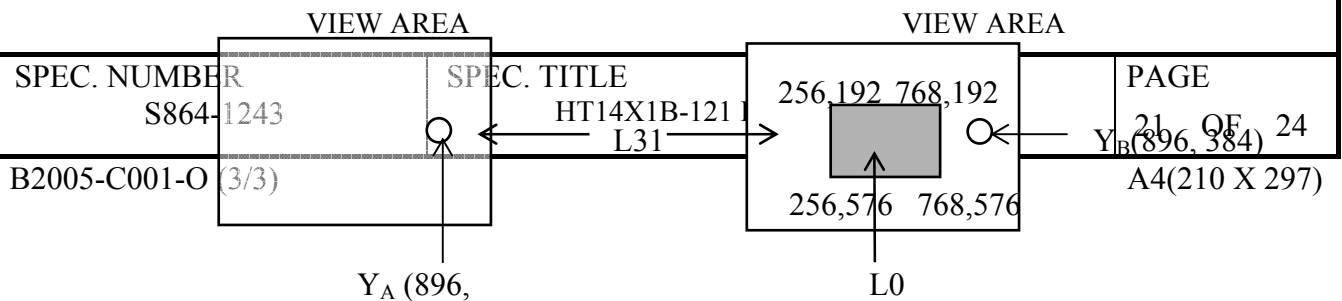

Figure 5. Cross Modulation Test Description



$$\text{Cross-Talk (\%)} = \left| \frac{Y_B - Y_A}{Y_B} \right| \times 100$$

Where:

Y_A = Initial luminance of measured area (cd/m²)

Y_B = Subsequent luminance of measured area (cd/m²)

The location measured will be exactly the same in both patterns

Figure 6. TFT-LCD Module Outline Dimensions (Front view)

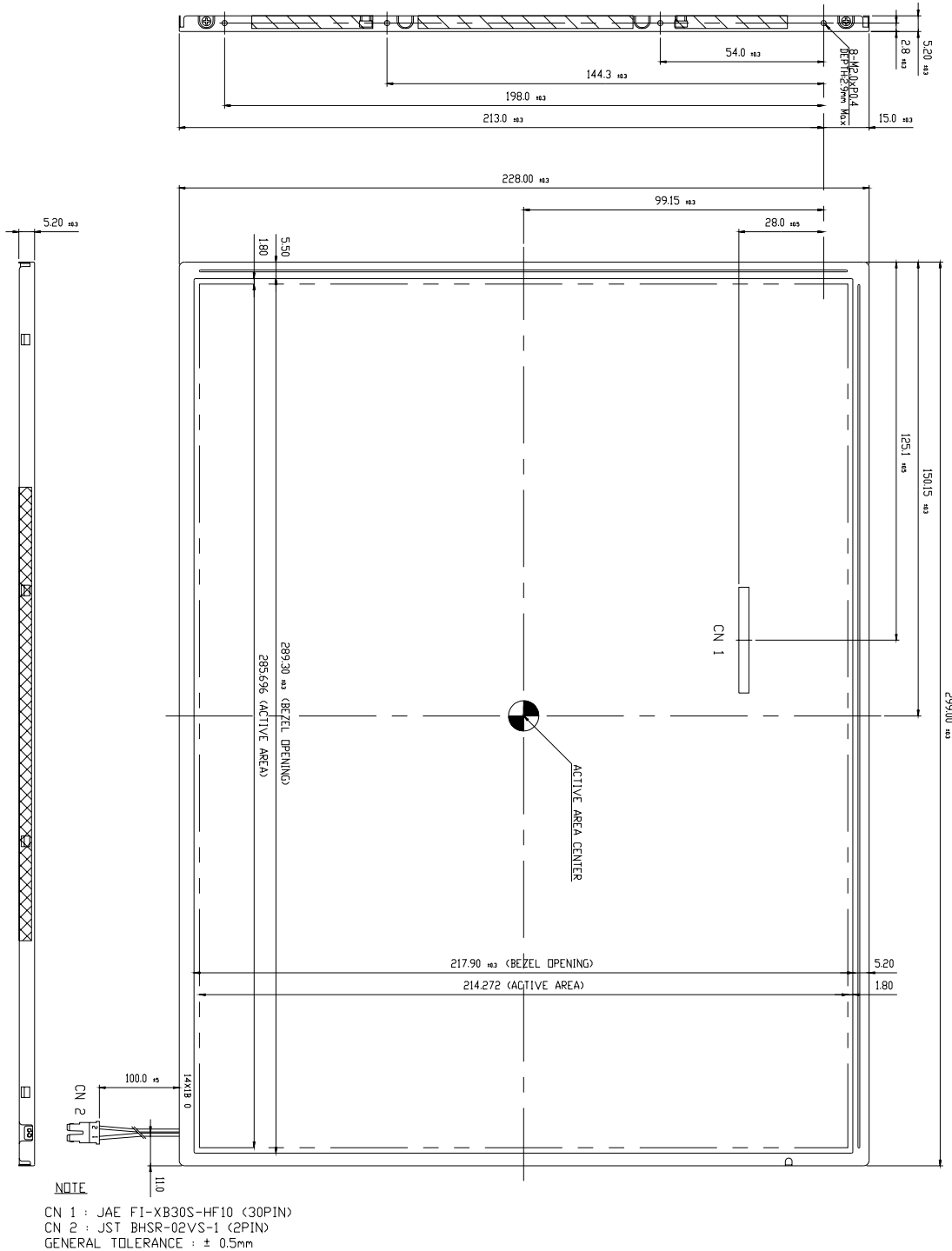

Figure 7. TFT-LCD Module Outline Dimensions (Back view)



PRODUCT GROUP

REV.

ISSUE DATE

TFT-LCD PRODUCT

O

2005. 10. 04

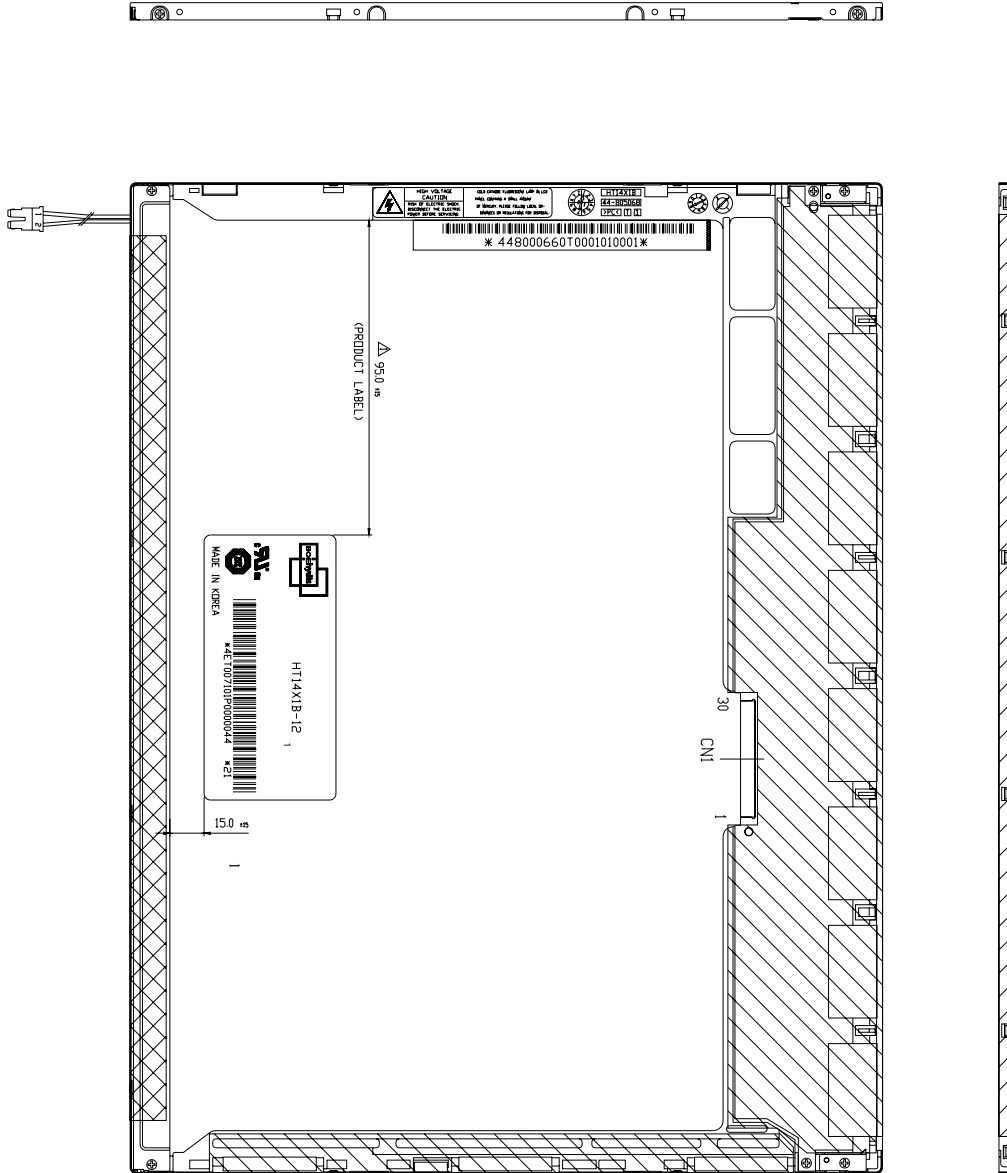

SPEC. NUMBER
S864-1243

SPEC. TITLE
HT14X1B-121 Product Specification

PAGE
24 OF 24